

# K i n d e r

---

FIRES FOR LIFE

# Kalahari Plus Camber Plus

**INSET LIVE FUEL-EFFECT GAS FIRES**

**Installation, Maintenance & User Instructions.**

**Hand these instructions to the user after installation.**

**Model No's KKPC\*\*MN, KKPC\*\*SN, KKPC\*\*TN, KKPC\*\*RN, KCPP\*\*MN & KCPP\*\*RN are for use on Natural Gas (G20) at a supply pressure of 20 mbar in G.B. / I.E.**

**\*\* denotes variant of trim / fascia where applicable**

## CONTENTS PAGE

<b>Section 1</b>	<b>Information and Requirements</b>	<b>PAGE</b>
1.0	Appliance Information	3-4
1.1	Conditions of Installation	5
1.2	Flue and chimney suitability	5
1.3	Fireplace / surround suitability	6
1.4	Shelf position	6
1.5	Chimney inspection	6-7
1.6	Fire place opening / catchment space	7-8
1.7	Fitting to metal flue boxes	8
1.8	Hearths	9
1.9	Pre-cast flue installations	9
1.10	Spillage monitoring system	9
<b>Section 2</b>	<b>Installation of Fire</b>	
2.1	Unpacking the fire	10
2.2	Installing the fire box	10-18
2.3	Gas tightness and inlet pressure (manual control models)	18
2.4	Gas tightness and inlet pressure (slide control models)	18
2.5	Gas tightness and inlet pressure (remote / electronic fire control models)	19
<b>Section 3</b>	<b>Assembling Fuel Bed and Commissioning</b>	
3.1/3.2	Assembling the ceramics and fuel bed (coal/pebble variants)	20-26
3.3	Fixing the Infra-red eye in position	27
3.4	Connecting the battery pack	28
3.5	Fitting the trim	28
3.6	Fitting the fender	28
3.7	Lighting the appliance (manual control models)	29
3.8	Lighting the appliance (slide control models)	30
3.9	Lighting the appliance (remote control models)	31
3.10	Lighting the appliance (electronic fire control models)	32
3.11	Checking for clearance of combustion products	33-34
<b>Section 4</b>	<b>Maintenance</b>	
4.1	Removal of the burner assembly (manual control models)	35
4.2	Removal of the piezo igniter (manual control models)	35
4.3	Removal of the control tap (manual control models)	36
4.4	Removal of the pilot assembly (manual control models)	36
4.5	Removal of the burner assembly (slide control models)	36-37
4.6	Removal of the battery igniter (slide control models)	37
4.7	Replacing the battery (slide control models)	37
4.8	Removing the oxy-pilot assembly (slide control models)	38
4.9	Replacing the control cable (slide control models)	38-39
4.10	Removal of the burner assembly (remote & electronic fire control models)	40
4.11	Removal of the valve (remote & electronic fire control models)	40
4.12	Removal of the oxy-pilot assembly (remote & electronic fire control models)	40-41
4.13	Replacing the batteries (remote & electronic fire control models)	41
4.14	Removal of the trim switch (electronic fire control models)	41
	Part Shortlist / Fret Information	42
<b>Section 5</b>	<b>User Instruction Section</b>	
5.1	Conditions of Installation & about your new fire	42-44
5.2	Operating the fire (manual control models)	45
5.3	Operating the fire (slide control models)	46-47
5.4	Operating the fire (remote control models)	47-48
5.5	Operating the fire (electronic fire control models)	48-49
5.6	Remote handset / EFC trim switch malfunction	50
5.7/5.8	Replacing the batteries in slide and remote / electronic fire control models	51
5.9/5.10	Spillage monitoring system/ cleaning instructions	51-52
5.11	Re-assembling the ceramics and fuel bed	53-60

## SECTION 1 INFORMATION AND REQUIREMENTS

### 1.0 APPLIANCE INFORMATION

Model	KKPC**MN (MC) KKPC**SN (SC) KKPC**RN (RC) KKPC**TN (EFC) KCPP**MN (MC) KCPP**RN (RC)
Gas Type	G20
Main injectors (2 off)	Size 260
Pilot Type	Copreci 21100 / 141 (MC) 21100 / 162 (SC, RC & EFC)
Max. Gross Heat Input :	6.9 kW
Min. Gross Heat Input :	4.2 kW
Cold Pressure :	20.0 mbar +/- 1.0mbar
Ignition :	Push Button Piezo (MC models) 1.5V Battery Generator (SC models) 9V Battery Generator (RC & EFC models)
Electrode Spark Gap	4.5mm Nominal
Weight	14kg

This appliance is manufactured by:-

BFM Europe Ltd,  
Trentham Lakes,  
Stoke-on-Trent,  
ST4 4TJ.

### **Fire box Dimensions (Kalahari Plus Models)**

Width :	(with trim, no spacer)	498mm
Height :	(with trim, no spacer)	600mm
Depth :	(overall-without fender)	170mm

Gas Connection            8mm Compression            (Supplied with fire)

### **Fire box Dimensions (Camber Plus Models)**

Width :	(with trim)	534mm
Height :	(with trim)	616mm
Depth :	(overall-without fender)	170mm

Gas Connection            8mm Compression            (Supplied with fire)

### **Efficiency Declaration**

The efficiency of this appliance has been measured as specified in BS 7977-1 : 2002 and the result is 63%. The gross calorific value of the fuel has been used for this efficiency calculation. The test data from which it has been calculated has been certified by BSI. The efficiency value may be used in the UK Governments Standard Assessment Procedure (SAP) for energy rating of dwellings.

# INSTALLATION REQUIREMENTS

## 1.1 CONDITIONS OF INSTALLATION

It is the law that all gas appliances are installed only by a GAS SAFE Registered Installer, in accordance with these installation instructions and the Gas Safety (Installation and Use) Regulations 1998 as amended. Failure to install appliances correctly could lead to prosecution. It is in your own interest and that of safety to comply with the law.

The installation must also be in accordance with all relevant parts of the Local and National Building Regulations where appropriate, the Building Regulations (Scotland Consolidation) issued by the Scottish Development Department, and all applicable requirements of the following codes of practice :-

1. BS 5871 Part 2 Installation of Inset Live Fuel Effect Gas Fires
2. BS 6891 Installation of Gas Pipework
3. BS 5440 Parts 1 & 2 Installation of Flues and Ventilation
4. BS 1251 Open fire place components
5. BS 715 / BS EN 1856-2 Metal flue pipes for gas appliances
6. BS 6461 Part 1 Installation of Chimneys and flues
7. IS 813 : 1996 Domestic Gas Installation (Republic of Ireland)

**No purpose made additional ventilation is normally required for this appliance, when installed in G.B. When Installing in I.E. please consult document I.S. 813 : 1996 Domestic Gas Installation, which is issued by the National Standards Authority of Ireland. If installing in Northern Ireland, please consult local building regulations. Any purpose made ventilation must be checked periodically to ensure that it is free from obstruction.**

## 1.2 FLUE AND CHIMNEY SUITABILITY

This appliance is designed for use with conventional brick built or lined chimneys and fabricated flues and metal flue boxes conforming to BS 715 / BS EN 1856-2. All flues must conform to the following minimum dimensions.

<b>Minimum diameter of circular flues</b>	<b>125 mm (without flue restrictor fitted)</b>
<b>Minimum effective height of all flue types</b>	<b>3 metres</b>

**When fitting to conventional chimneys or 175mm flues it may be desirable to fit the flue restrictor baffle (supplied) to reduce the flue flow and increase the efficiency of the fire. Safe clearance of products must always be checked by carrying out a smoke match test as described.**

### 1.3 FIREPLACE / SURROUND SUITABILITY

The fire must only be installed on a hearth it **must not be installed directly onto carpet or other combustible floor materials.**

The fire is suitable for fitting to non-combustible fire place surrounds and proprietary fire place surrounds with a temperature rating of at least 150°C.

**If a heating appliance is fitted directly against a wall without the use of a fire surround or fire place all combustible material must be removed from behind the trim. Soft wall coverings such as blown vinyl, wall paper etc. could be affected by the rising hot air and scorching and/or discoloration may result. Due consideration should be made to this when installing or decorating.**

### 1.4 SHELF POSITION

The fire may be fitted below a combustible shelf providing there is a minimum distance of 200mm above the top of the fire and the shelf does not project more than 150mm. If the shelf overhangs more than 150mm the distance between the fire and the shelf must be increased by 15mm for every 25mm of additional overhang over 150mm.

### 1.5 FLUE / CHIMNEY INSPECTION

Before commencing installation, a flue or chimney should be inspected to ensure that all the following conditions are satisfied.

1. Check that the chimney / flue only serves one fire place and is clear of any obstruction. Any dampers or register plates must be removed or locked in the open position.
2. Brick/stone built chimneys or any chimney or flue which has been used for an appliance burning fuel other than gas must be thoroughly swept. The base of the chimney / flue must also be thoroughly cleared of debris etc.
3. Any under-floor air supply to the fire place must be completely sealed off.
4. Ensure that the inside of the chimney / flue is in good condition along its length and check that there is no leakage of smoke through the structure of the chimney during and after the smoke pellet test.
5. **Using a smoke pellet, check that there is an up-draught in the chimney / flue and that the smoke can be seen issuing from the terminal / chimney pot outside. There must be no leakage of smoke through the structure of the chimney during or after the smoke pellet test and it is important to check inside upstairs rooms adjacent to the chimney / flue.**

Check the chimney pot / terminal and general condition of the brickwork or masonry. If the chimney or flue is in poor condition or if there is no up-draught do not proceed with the installation. If there is a history of down-draught conditions with the chimney / flue, a tested and certificated flue terminal or cowl suitable for the relevant flue type should be considered.

6. **A spillage test must always be carried out during commissioning of the appliance.**

### 1.6 FIRE PLACE OPENING AND CHIMNEY CATCHMENT SPACE

The front opening of the fire place must be between 370 and 440mm wide, and between 550 and 570mm high. If the opening exceeds these dimensions then a surround must be constructed from suitable non-combustible material to produce a correct size opening. Any surround must be suitably sealed to the fire place to prevent leakage. See below in figure 1.

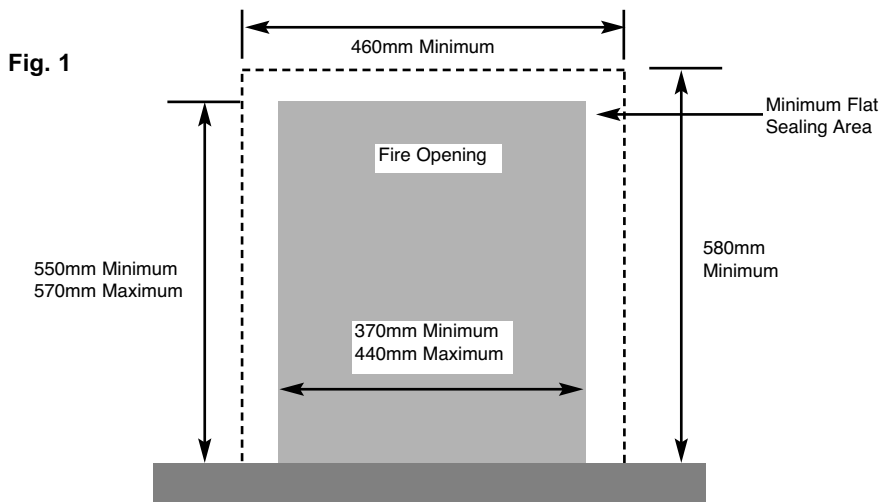

When installing into a brick built chimney, you must ensure that there is sufficient depth to accommodate any debris which may fall from the chimney. This depth must be sufficient to accommodate 12 litres of volumetric space.

**Table A - Installation Depth Requirements for a Kinder Kalahari / Camber Plus being installed into a brick built chimney, requiring 12.0 litres of debris collection volume (figure 2)**

When installing this product into a builders opening / brick-built chimney, the depth required is a minimum of 170mm. The 12.0 litres of debris collection volume is achieved by the space available taper down the sides of the firebox. This depth can be reduced to 120mm if the black 50mm spacer frame is used. This spacer frame can be purchased from Kinder Fires as an optional extra (not suitable for use with Camber Plus models). This appliance is suitable for use in fireplaces fitted with an existing chairbrick without the need for removal of the chairbrick, providing the minimum depth of the fireplace exceeds 260mm. If the depth is less than 260mm then the spacer (optional) must be used to give a minimum clearance from the rear of the fire to the rear of the chairbrick of at least 90mm to allow sufficient space for the collection of debris which may fall down the chimney. The fireplace must be checked to ensure that no part of the chairbrick is within 50mm of the flue outlet of the fire when installed.

For example, if the appliance was to be fitted into a 370mm wide opening (without a chairbrick), the depth required would be 170mm. See fig. 2 below for explanatory diagram.

**Fig. 2**

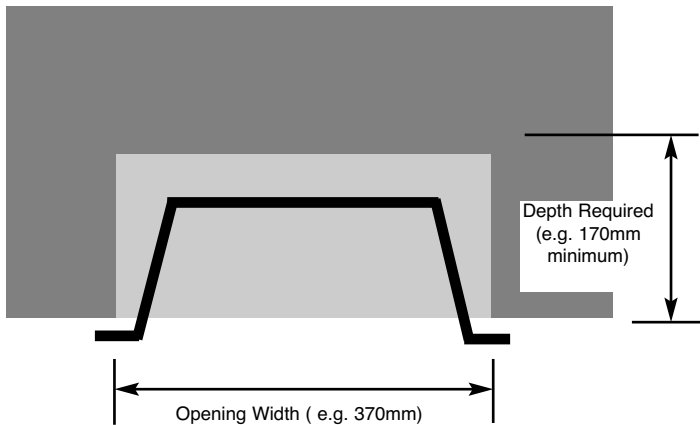

**1.7 FITTING TO PRE-FABRICATED TWIN WALL METAL FLUE BOXES**

The appliance may be fitted to twin wall metal flue boxes conforming to the constructional requirements of BS 715 / BS EN 1856-2, (for example the Selkirk LFE 175 box). The box must have a minimum flue diameter of 125mm internal and minimum internal dimensions of 300mm deep by 580mm high by 400mm wide. There are no maximum dimensional requirements for the box. The top face of the box must be insulated with a minimum thickness of 50mm of non-combustible mineral wool insulation or similar material. The flue box must stand on a non-combustible base of minimum thickness 12mm.



## 1.8 HEARTHS

This appliance must only be installed on to a concrete or non-combustible hearth. The hearth material must be a minimum thickness of 13mm with the top surface at least 50mm above the floor. The hearth must be fitted symmetrically about the fire opening and have a minimum width of 760mm and a minimum projection of 300mm forwards from the fire opening. EFC models required an increased hearth projection of 320mm forwards of the fireplace opening.

## 1.9 FITTING TO PRE-CAST FLUE INSTALLATIONS

**When installing this appliance into pre-cast flues, always ensure that the spigot restrictor baffle has been removed. To install the fire box in to pre-cast flue starter blocks, there must be at least 170mm from the mounting face of the fire to the rear of the pre-cast flue starter block** to allow sufficient space for debris collection. It is important to consider this depth when choosing a fire surround as the thickness of the fire surround must be sufficient to give a total depth of **at least 170 mm to the rear of the starter block**, otherwise there will be insufficient depth. To increase this depth the optional black 50mm spacer frame may be purchased (not suitable for use with Camber Plus models), this will reduce the depth required to **120mm** or the fire surround may be packed away from the wall using suitable non-combustible board, providing the installation is correctly sealed. If in doubt about the suitability of the fire contact Kinder Fires for advice before proceeding. **This fire has been designed to fit standard 100mm pre-cast starter blocks with 3 inch rebated surrounds.** It is important to ensure that the pre-cast flue is in good condition and is free from extruded mortar or sealant from between the flue blocks.

**This appliance has been tested for use in a pre-cast flue block complying with BS EN 1858. In accordance with BS EN 1858, pre-cast flues built with directly plastered faces (front or rear) are not correctly installed as to ensure proper operation with any type of gas fire. In some instances of this flue construction, temperature cracking of surface plaster may occur through no fault of the appliance. An air gap or some form of insulation material should be installed to prevent normal flue temperatures from damaging wall surfaces.**

### 1.10 SPILLAGE MONITORING SYSTEM

This appliance is fitted with an atmosphere sensing spillage monitoring system in the form of an oxygen sensing pilot. This is designed to shut the fire off in the event of a partial or complete blockage of the flue causing a build up of combustion products in the room in which the fire is operated. **The following are important warnings relating to this spillage monitoring system :-**

- 1) The spillage monitoring system must not be adjusted by the installer.
- 2) The spillage monitoring system must not be put out of operation.
- 3) When the spillage monitoring system is exchanged only a complete original manufacturers part may be fitted. It is not possible to replace individual parts on the pilot system on this appliance, only a complete pilot assembly (including the thermocouple) may be fitted.

## SECTION 2 INSTALLATION OF FIRE

### 2.1 UNPACKING THE FIRE

Carefully lift the fire out of the carton. Remove the loose item packaging carefully from the front of the appliance. Check the contents as listed :-

#### Packing Check List

- 1 off Fire box / burner assembly
- 1 off Boxed ceramic base, front ceramic rail and 18 coals (16 large, 2 small) - Kalahari Plus models only  
or  
Boxed ceramic base, front ceramic rail and 14 pebbles (12 large, 2 small) - Camber Plus models only
- 1 off Loose items bag, which includes (where applicable) :-
- 1 off Remote control handset (RC models only)
- 1 off Restrictor baffle (all models)
- 1 off Cable fixing kit (all models)
- 1 off 45mm grommet (all models)
- 1 off Installation & user instruction book (all models)
- 1 off Battery pack (RC & EFC models only)
- 6 off 1.5V batteries (RC & EFC models only)
- 1 off 9V battery (RC models only)
- 1 off 1.5V battery (SC models only)
- 1 off Guarantee card (all models)
- 1 off Camber fascia (Camber Plus models only)
  
- 1 off Pebble set (if ordered as an optional extra) pack 2 of 2

### 2.2 INSTALLING THE FIRE BOX

**Establish which type of flue you are intending to install the fire in to :-**

225 x 225mm (9 inch x 9 inch) brick built chimneys 175mm (7 inch) diameter lined brick or stone flue, insulated pre-fabricated metal flue box to BS 715 / BS EN 1856-2 or Pre-Cast Flue to BS EN 1858

When installing into 125mm (5 inch) diameter lined brick or stone flue, or insulated pre-fabricated metal flue box to BS 715 / BS EN 1856-2. the restrictor baffle must not be fitted.

**A spillage test must always be carried out to check satisfactory clearance of flue products, regardless of the type of flue the appliance is being fitted to.**

**For manual control models proceed as follows :-**

- a) Remove the burner heat shield from the front of the fire box to allow access to the burner. See figure 3 below.

**Fig. 3**

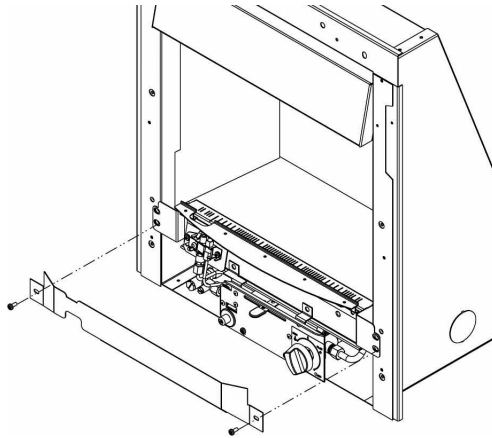

- b) Ensure that the hearth is protected from damage and carefully lift the fire box into the fire opening, then slide it back into position. Check that the fire box flange fits flush to the sealing face of the fire surround or wall with no gaps present.
- c) Remove the four retaining screws securing the burner to the firebox. The base of the burner unit can now be pulled forward, allowing the burner to be removed from the fire box. See figure 4 below.

**Fig. 4**

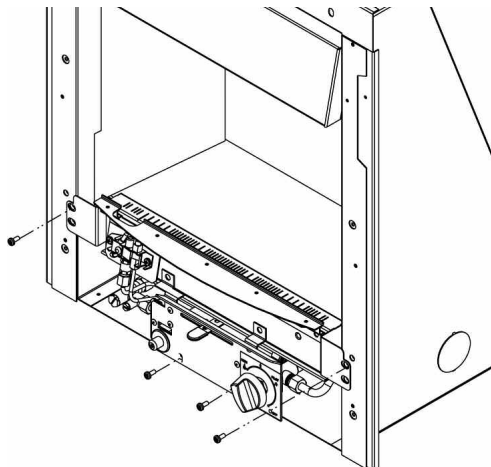

**For slide control models proceed as follows:**

- d) Remove the burner heat shield from the front of the fire box to allow access to the burner. See figure 5 below.

**Fig. 5**

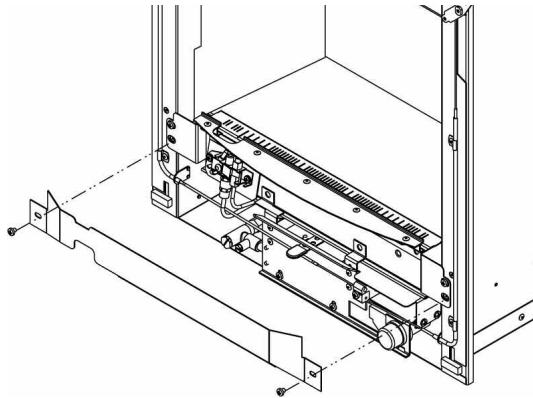

- e) Ensure that the hearth is protected from damage and carefully lift the fire box into the fire opening, then slide it back into position. Check that the fire box flange fits flush to the sealing face of the fire surround or wall with no gaps present.
- f) Remove the burner. To allow burner removal, the control lever operating cable must be removed. The control lever operating cable can be seen running across the base of the fire, below the burner. To release the cable, unscrew the cable securing screw located in the centre of the aluminium operating arm and release the front part of the operating arm, thereby freeing the cable from the burner. Note the securing screw is retained in the block to prevent it from being lost. Release the other end of the cable by pushing the cable forwards to the right, i.e. into the operating arm so as to release the tension. Pull the cable nipple out of the retaining hole and remove the cable through the slot in the operating arm. See figure 6 overpage

**Fig. 6**

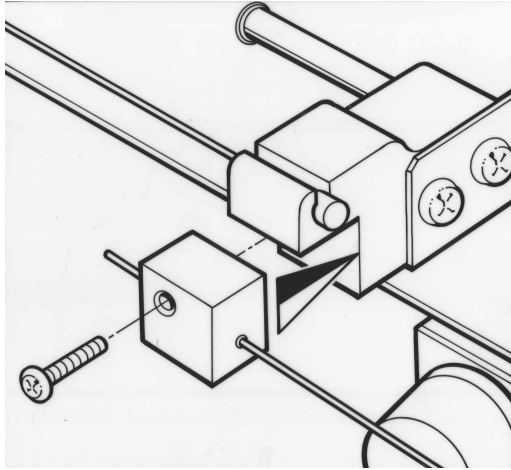

- g) Unscrew the burner assembly fixing screws at either side of the firebox, and the two fixing screws at the base of the fire (see figure 7 below). Carefully pull the base of the burner forwards. The burner can now be removed from the appliance.

**Fig. 7**

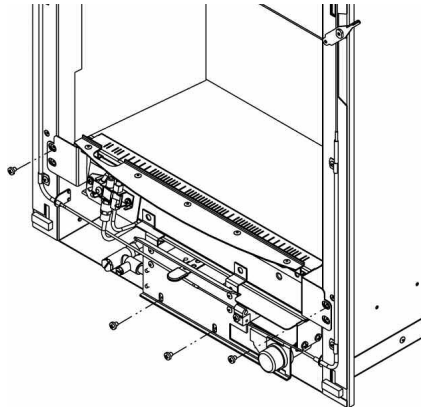

**For remote & electronic fire control models proceed as follows:**

- h) Remove the trim. Remove the burner heat shield from the front of the fire box to allow access to the burner. See fig. 8 below.

**Fig. 8**

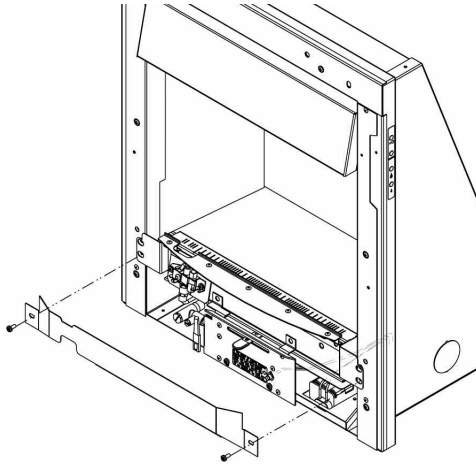

- i) Ensure that the hearth is protected from damage and carefully lift the fire box into the fire opening, then slide it back into position. Check that the fire box flange fits flush to the sealing face of the fire surround or wall with no gaps present.
- j) Remove the four retaining screws securing the burner to the firebox. The base of the burner unit can now be pulled forward, allowing the burner to be removed from the fire box. See figure 9 below.

**Fig. 9**

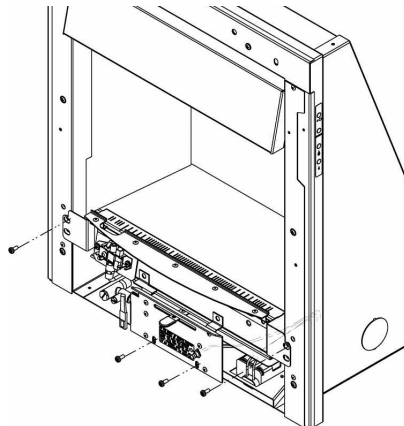

## Continue for all models

Whilst the fire box is still in position, decide which side the gas supply is to enter the fire from. If concealed pipe work is required plan the pipe run to enter the fire box through one of the openings in the sides of the fire box below the fuelbed support panel and connect to the isolating / inlet elbow. The gas connection to the appliance should be made to the isolating / inlet elbow using 8mm rigid tubing. There must be no soldered joints within the firebox. See figure 10 & 11 below for suggested concealed pipe layouts.

**Fig. 10**

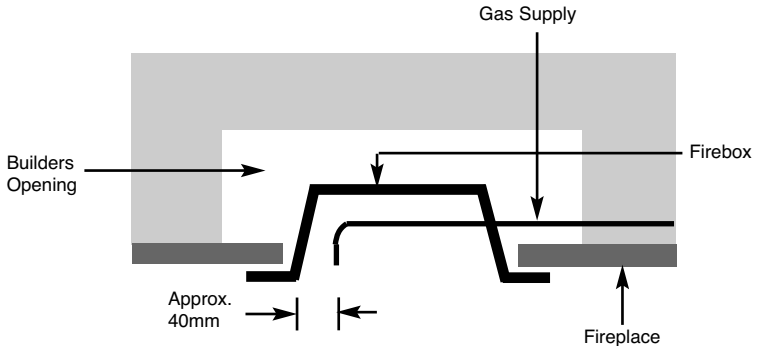

**Fig. 11**

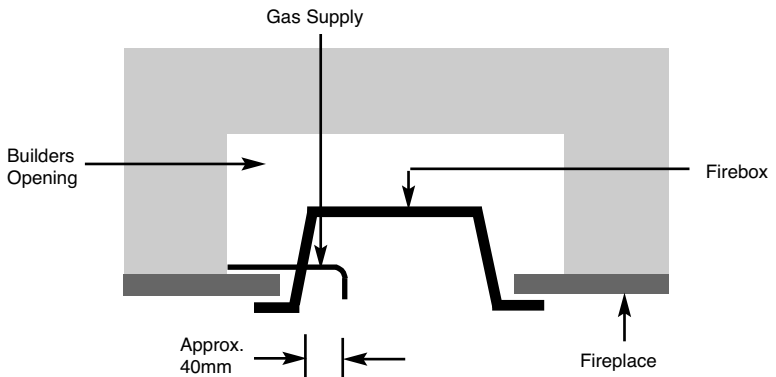

**Note :** Before breaking into the gas supply a tightness test should be carried out to establish that the existing pipework is sound.

Carefully withdraw the fire box from the opening to enable the gas supply and fire fixing to be completed.

**IMPORTANT :** THE 45MM GROMMET SUPPLIED IN THE LOOSE ITEMS MUST BE USED TO SEAL THE GAS INLET POINT UTILISED ON THE FIREBOX. FAILURE TO SEAL THIS INLET POINT COULD RESULT IN FLAME REVERSAL AND DAMAGE TO THE CONTROLS ON THE FIRE. BFM EUROPE ACCEPT NO RESPONSIBILITY FOR DAMAGE TO THE FIRE AS A RESULT OF FAILURE TO FOLLOW THIS REQUIREMENT.

**The preferred method of fixing which is suitable for almost all situations is the cable fixing method which is described in the following section in detail.**

To fit using the **preferred** cable method proceed as follows-

- h) Mark out and drill 4 off No 14 (6mm) holes in the back face of the fire opening in the positions shown below in figure 12

**Fig. 12**

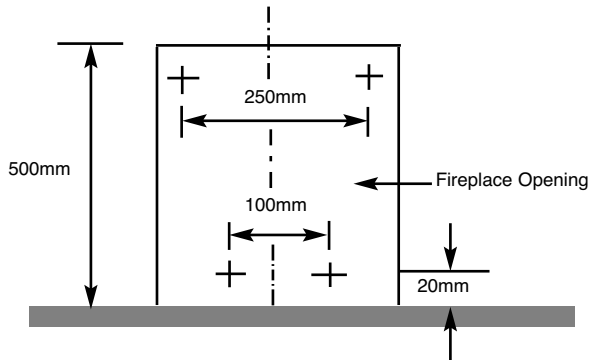

Fit the wallplugs provided and screw the fixing eyes securely into the rear of the fire opening.

- i) Uncoil the two fire fixing cables and thread one end of each of the cables through one of the two holes on each side of the flue outlet shroud.
- j) Position the fire carefully on the (protected) surface of the hearth and reach into the fire opening. Thread each of the cables vertically downwards through the pair of fixing eyes on the same side of the fire. Thread the free end of the cables through the corresponding circular hole on each side of the lower rear of the fire. Carefully slide the fire box back into the fire opening and pull both cables tight.
- k) Thread a tensioning screw over each of the cables and ensure that the tensioning nut is screwed fully up against the hexagon shoulder of the tensioning screw (this provides maximum travel for the tensioning nut).
- l) Fit a screwed nipple on to each of the cables and pull hand tight up against the tensioning screw, then secure each nipple with a flat bladed screwdriver. See figure 13 overpage.



**Fig. 13**

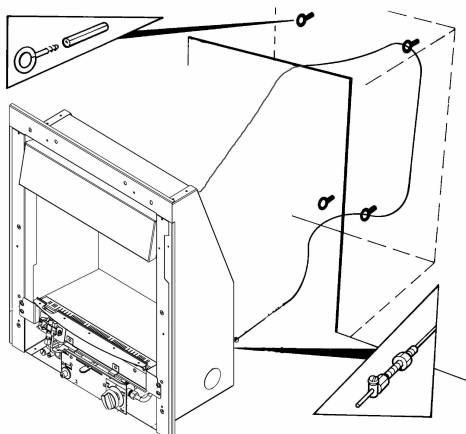

- m) Evenly tighten the tensioning nuts to tension both cables and pull the fire snugly against the wall. Do not overtighten, it is only necessary to pull the seal up against the sealing face of the wall, it does not need to be compressed. Check that there are no gaps behind the seal.
- n) With the fire securely in place, if a concealed gas connection has been made through either of the access holes in the sides of the fire, the holes should be closed around the pipe to prevent leakage of air through the gap around the pipe.
- o) Refit the burner. Fit the four retaining screws and check that the burner is correctly locked into position. On slide control models refit the control cable. To do this, firstly locate the nipple on one end of the cable into recess in operating arm and then secure the front part of the operating arm back onto the rear of the operating arm with the retained screw. This should not be overtightened. Move the control lever fully downwards and check that the left hand micro-switch operates the igniter and that the control valve spindle is fully depressed. Move the control lever upwards to the "off" position and check that the control lever operates smoothly and safely.

**NOTE : The cable is factory set, and therefore should need no adjustment**

- p) Refit the front burner heat shield to the sides of the fire box (2 screws)

- q) **Before making the final gas connection, thoroughly purge the gas supply pipework to remove all foreign matter, otherwise serious damage may be caused to the gas control valve on the fire.**

### **2.3 GAS TIGHTNESS AND INLET PRESSURE - MANUAL CONTROL MODELS.**

- a) Remove the pressure test point screw from the inlet elbow and fit a manometer.
- b) Turn on the main gas supply and carry out a gas tightness test.
- c) Depress the control knob and turn anti-clockwise to the position marked pilot. Hold in the control knob for a few seconds to purge the pipe work then press the igniter button. The burner should light, continue to hold the control knob for a few seconds then turn to the full-on position.
- d) Check that the gas pressure is **20.0 mbar (+/- 1.0mbar) 8.0 in w.g.(+/- 0.4 in w.g.)**
- e) Turn off the fire, remove the manometer and refit the pressure test point screw. Check the pressure test point screw for gas tightness with the appliance turned on using a suitable leak detection fluid or detector.

### **2.4 GAS TIGHTNESS AND INLET PRESSURE - SLIDE CONTROL MODELS.**

- a) Remove the pressure test point screw from the pressure test point and fit a manometer.
- b) Turn on the main gas supply and carry out a gas tightness test.
- c) Depress the control lever to the position marked pilot. Hold down the control lever for a few seconds to purge the pipe work. The burner should light, continue to hold the control lever for a few seconds to latch the valve then lift to the full-on position.
- d) Check that the gas pressure is **20.0 mbar (+/- 1.0mbar) 8.0 in w.g.(+/- 0.4 in w.g.)**
- e) Turn off the fire, remove the manometer and refit the pressure test point screw. Check the pressure test point screw for gas tightness with the appliance turned on using a suitable leak detection fluid or detector.

## 2.5 **GAS TIGHTNESS AND INLET PRESSURE - REMOTE CONTROL OR ELECTRONIC FIRE CONTROL MODELS**

- a) Remove the pressure test point screw from the inlet elbow and fit a manometer.
- b) Turn on the main gas supply and carry out a gas tightness test.
- c) Light the fire, see page 31 / 32 for full details of the operating method for the fire.
- d) Check that the gas pressure is **20.0 mbar (+/- 1.0mbar) 8.0 in w.g.(+/- 0.4 in w.g.)**
- e) Turn off the fire, remove the manometer and refit the pressure test point screw. Check the pressure test point screw for gas tightness with the appliance turned on using a suitable leak detection fluid or detector.

### SECTION 3 ASSEMBLING FUEL BED AND COMMISSIONING

#### 3.1 ASSEMBLING THE CERAMICS AND FUEL BED - COAL MODELS

- a) Place the ribbed ceramic fuelbed base on top of the fuelbed support and pull fully forwards to the burner. **Make sure that the fuelbed base is located centrally in the fire box. Ensure that the fuelbed base fit fully down onto the fuel bed support and is not lodged on the burner. See figure 14 below.**

Fig. 14



- b) Position the two halves of the front ceramic (L/H & R/H) on the locating channel in the front ceramic, ensuring it is located onto the lip on the burner front ceramic support. (See figure 15 below)

Fig. 15



- c) Fit five of the large sized coals onto the front ceramic rail, ensuring that they are evenly spaced. Use the recess's in the front ceramic rail as a guide for placement. (See figure 16 below)

**Fig. 16**



- d) Select four of the large coals and arrange behind the front row of coals, ensuring that flame paths as indicated below are not interrupted. (See figure 17 below)

**Fig. 17**

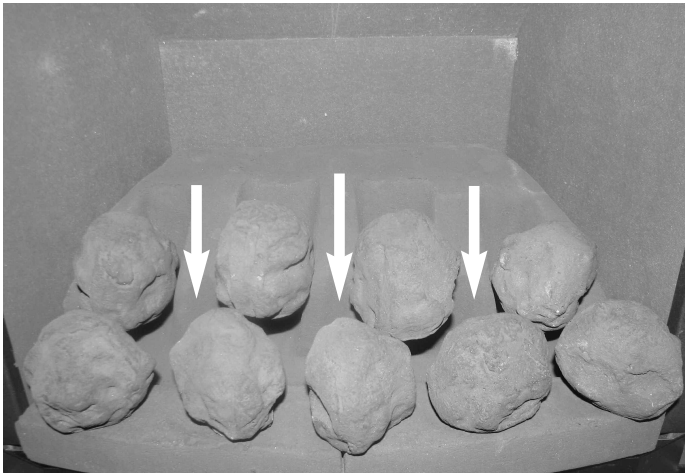

- e) Select three of the large coals and arrange along the rear of the fuelbed, using the ribs in the rear of the fuelbed as a guide for placement. (See figure 18 below)

**Fig. 18**



- f) Select two small coals and position to fill the gaps at each end of the third row of coals, as shown. (See figure 19 below).

**Fig. 19**

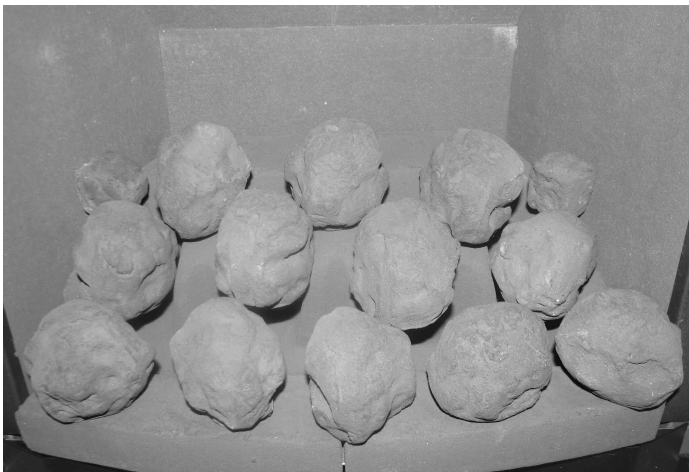

- g) Select the remaining four large coals and position on the rear of the fuel-bed matrix. (See figure 20 below).

**Fig. 20**

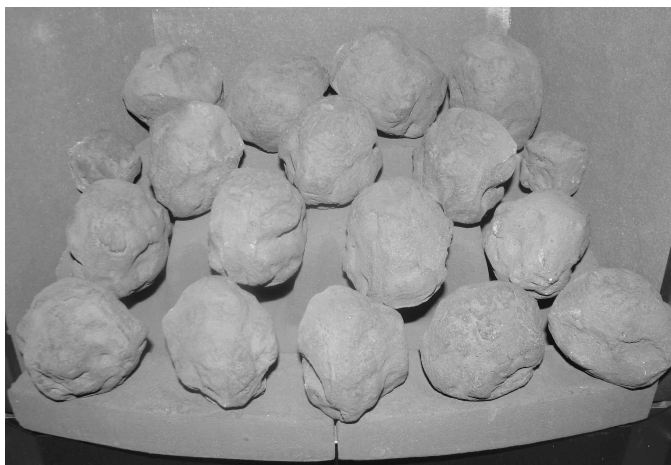

The exact position and fit of the coals may be finely adjusted to give the most pleasing and random appearance.

**Warning : Use only the coals supplied with the fire. When replacing the coals remove the old coals and discard them. Fit a complete set of coals of the correct type. Do not fit additional coals or any coals other than a genuine replacement set.**

This appliance uses fuel effect pieces containing Refractory Ceramic Fibres (R.C.F.), which are man-made vitreous silicate fibres. Excessive exposure to these materials may cause temporary irritation to eyes, skin and respiratory tract. Consequently, it makes sense to take care when handling these articles to ensure that the release of dust is kept to a minimum. To ensure that the release of fibres from these R.C.F. articles is kept to a minimum, during installation & servicing we recommend that you use a HEPA filtered vacuum to remove any dust and soot accumulated in and around the fire, before and after working on the fire. When replacing these articles we recommend that the replaced items are not broken up, but are sealed within a heavy duty polythene bag, clearly labelled as "RCF waste". This is not classified as "hazardous waste" and may be disposed of at a tipping site licensed for the disposal of industrial waste. Protective clothing is not required when handling these articles, but we do recommend you follow the normal hygiene rules of not smoking, eating or drinking in the work area, and always wash your hands before eating or drinking. This appliance does not contain any component manufactured from asbestos or asbestos related products.

### 3.2 ASSEMBLING THE CERAMICS AND FUEL BED - PEBBLE MODELS

- a) Place the ribbed ceramic fuelbed base on top of the fuelbed support and pull fully forwards to the burner. **Make sure that the fuelbed base is located centrally in the fire box. Ensure that the fuelbed base fit fully down onto the fuel bed support and is not lodged on the burner. (See figure 21 below).**

Fig. 21



- b) Position front ceramic rail on burner front ceramic support and ensure that the locating channel in the front ceramic rail is correctly located onto the lip on the burner front ceramic support. (See figure 22 below).

Fig. 22

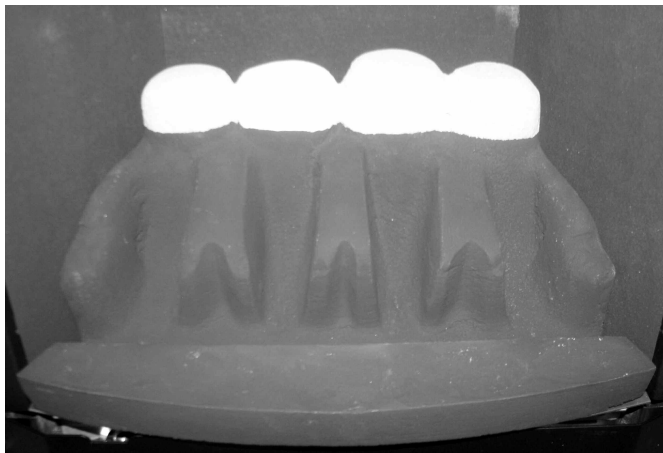



- c) Pick pebbles A to E and arrange along the front rail, ensuring that they are evenly spaced. Use the recess's in the front ceramic rail as a guide for placement. (See figure 23 below).

**Fig. 23**

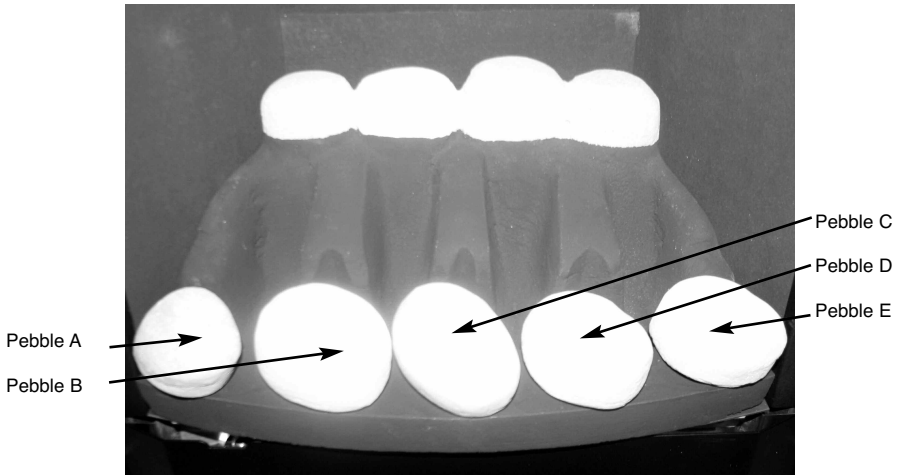

- d) Select pebbles F to I and arrange behind the front row of pebbles, ensuring that flame paths as indicated below are not interrupted. (See figure 24 below)

**Fig. 24**

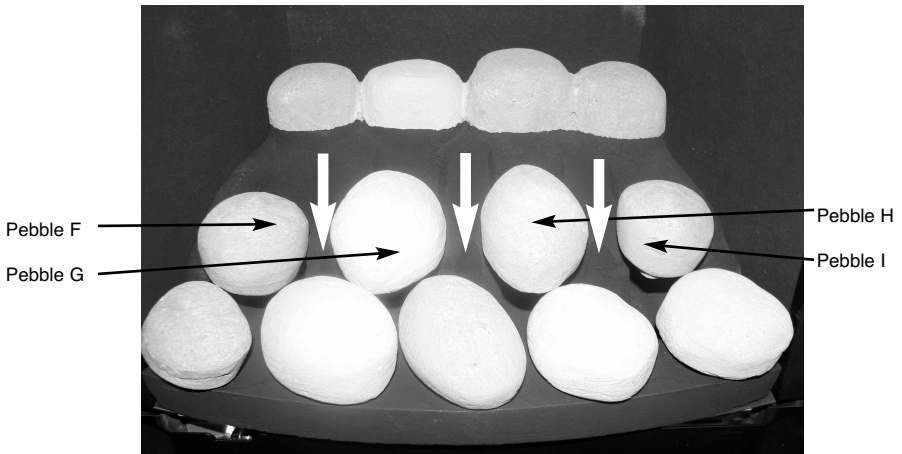

- e) Select pebbles K, L & M and arrange along the rear of the fuelbed, using the ribs in the rear of the fuelbed as a guide for placement. Select the two small pebbles (J & N) and position to fill the gaps at each end of the third row of pebbles (See figure 25 below).

**Fig. 25**

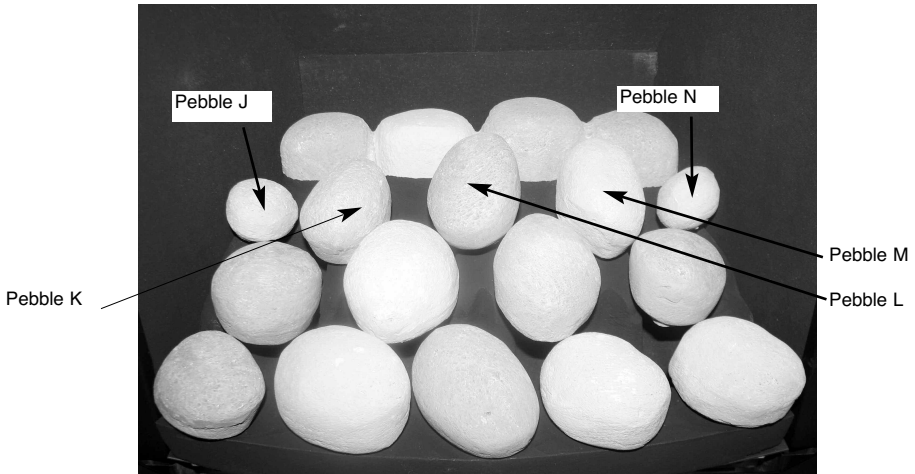

The exact position and fit of the pebbles may be finely adjusted to give the most pleasing and random appearance.

**Warning : Use only the pebbles supplied with the fire. When replacing the pebbles remove the old pebbles and discard them. Fit a complete set of pebbles of the correct type. Do not fit additional pebbles or any pebbles other than a genuine replacement set.**

This appliance uses fuel effect pieces containing Refractory Ceramic Fibres (R.C.F.), which are man-made vitreous silicate fibres. Excessive exposure to these materials may cause temporary irritation to eyes, skin and respiratory tract. Consequently, it makes sense to take care when handling these articles to ensure that the release of dust is kept to a minimum. To ensure that the release of fibres from these R.C.F. articles is kept to a minimum, during installation & servicing we recommend that you use a HEPA filtered vacuum to remove any dust and soot accumulated in and around the fire, before and after working on the fire. When replacing these articles we recommend that the replaced items are not broken up, but are sealed within a heavy duty polythene bag, clearly labelled as "RCF waste". This is not classified as "hazardous waste" and may be disposed of at a tipping site licensed for the disposal of industrial waste. Protective clothing is not required when handling these articles, but we do recommend you follow the normal hygiene rules of not smoking, eating or drinking in the work area, and always wash your hands before eating or drinking. This appliance does not contain any component manufactured from asbestos or asbestos related products.

### 3.3 FIXING THE INFRARED SENSOR IN POSITION

- a) Due to the different fascia's that can be supplied with these fires, the infrared sensor is supplied from the factory attached to a self adhesive pad. This pad can therefore be attached to the hearth in a position to suit the form of the fret assembly that is chosen with the product. Fig. 26 below shows the self adhesive pad and infrared eye attached to the flying lead, as supplied from the factory.

**Fig. 26**

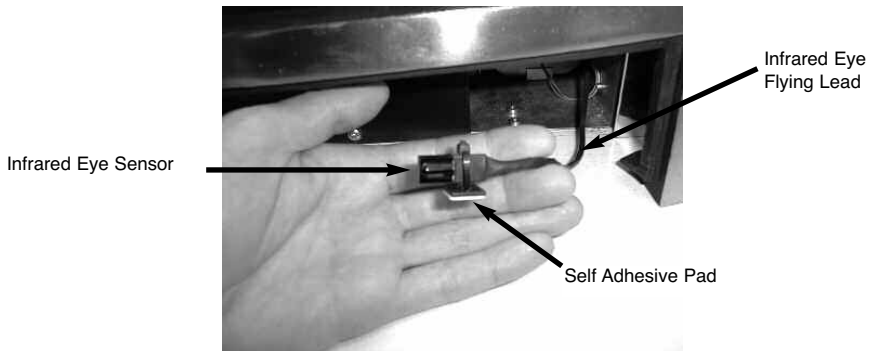

- b) Remove the backing paper from the self adhesive pad and position the infrared eye in the air channels in the ashpan cover, so that the infrared eye is flush with the front edge of the ashpan cover, as shown below in figure 27. Check the operation of the handset, as detailed in section 3.10 and adjust the position of the infrared eye if necessary.

**Fig. 27**

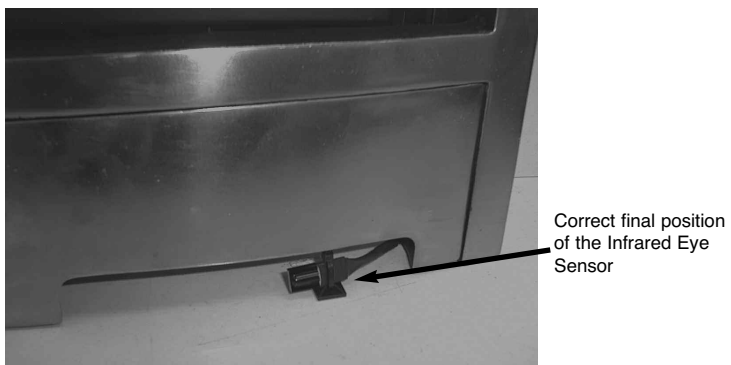

### 3.4 CONNECTING THE BATTERY PACK

- a) To prevent un-necessary battery drain, the battery pack that is used to provide the remote control function for this product is disconnected at the factory. Prior to attempting to light the product, can the installer please ensure that the battery pack is re-connected as shown in section b), c) & d) below.
- b) Locate the battery pack in the support cradle at the bottom R/H side of the firebox / burner assembly.
- c) The wire and connecting plug from the battery pack should then be connected into the supply wire running from the control board. See fig 28 below.

**Fig. 28**

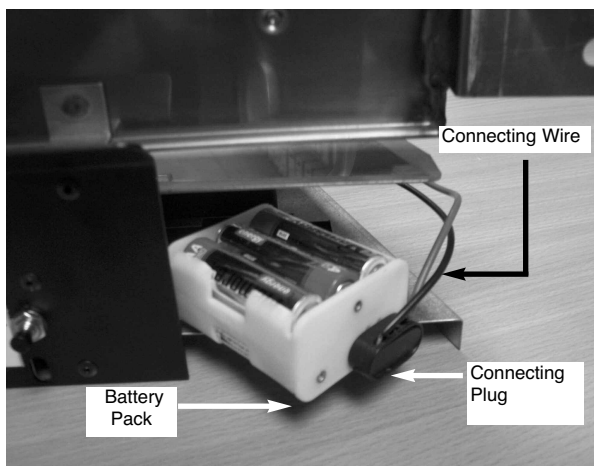

- d) Replace the battery pack into its mounting cradle below the burner.

### 3.5 FITTING THE TRIM

- a) The trim is held in position on the fixing flange by magnets.

### 3.6 FITTING THE FENDER

- a) The fender is placed up to the front of the ceramic front rail on all models. Position the ashpan under the fender and centralise.

### 3.7 LIGHTING THE APPLIANCE - MANUAL CONTROL MODELS

- a) Turn on the gas isolation tap.
- b) Depress the control knob and turn anti-clockwise to the position marked pilot. Hold in the control knob for a few seconds to purge the pipe work.
- c) Continue to hold-in the control knob and press the igniter button. If the burner does not light, continue to press the igniter button until ignition occurs. Continue to hold the control knob for 5-10 seconds to allow the thermocouple to heat up, if the pilot goes out when the control knob is released, repeat the lighting sequence.
- d) Turn the control knob in the anti-clockwise direction to the high position and the main burner will light.
- e) Turn the control knob clockwise to the low position and the gas input will be reduced to the minimum setting.
- f) Slightly depress the control knob and turn to the pilot position, the main burner will go out but the pilot will remain lit.
- g) Slightly depress the control knob and turn to the off position, the pilot will now be extinguished.

**WARNING : If the fire goes out for any reason or is turned off and it is necessary to re-light the fire it is important to allow the fire to cool for 3 minutes before attempting to re-light it.**

### 3.8 LIGHTING THE APPLIANCE - SLIDE CONTROL MODELS

- a) Turn on the isolation valve. Depress the control lever fully downwards to the position marked. Hold down the control lever for a few seconds to allow the gas to reach the pilot.
- b) The fire will then begin its ignition sequence. If the pilot does not light, continue to press the control lever until ignition occurs. The pilot flame can be seen by looking underneath the front ceramic rail, above the burner heat shield, at the front left hand side of the fuelbed. When the pilot has lit, continue to hold the control lever down for 5-10 seconds to allow the thermocouple to heat up, before releasing the lever apply one firm downwards push to ensure that the f.s.d. valve is fully latched, if the pilot goes out when the control lever is released, repeat the lighting sequence.
- c) After lighting, move control lever up to the high position and the main burner will light. It is recommended that for the most efficient performance the fire is allowed to warm up for a few minutes with the the control lever set to high.
- d) The gas control can be moved from the High to Low position to give the desired heat output.
- e) To turn the fire off, FULLY raise the control lever to the OFF position.

**WARNING : If the fire goes out for any reason or is turned off and it is necessary to re-light the fire it is important to allow the fire to cool for 3 minutes before attempting to re-light it.**

### 3.9 LIGHTING THE APPLIANCE - REMOTE CONTROL MODELS

- a) The Remote control handset generates an infrared signal, which will be received by the sensor situated at the front right of your fire, behind the ashpan cover. This infrared signal requires direct line of sight from the handset to the sensor on the fire to ensure good operation.
- b) To light the appliance using the handset, point the handset at the fire and press the 2 left hand buttons together. The fire will emit a “beep” sound, the buttons can now be released. After a few seconds an audible clicking can be heard and then the fire will light the pilot and then light the main burner. The ignition cycle will take approximately 20 seconds.
- c) To reduce the level of heat input on the fire, point the handset at the fire and press the small flame button. (An audible beep will be heard)
- d) To increase the level of heat input on the fire, point the handset at the fire and press the large flame button. (An audible beep will be heard)
- e) To leave the fire in the standby mode (pilot only running) press the small round button on the handset.
- f) To switch the appliance off completely, press the large round button on the handset, the fire will then switch off.

**Fig. 29**

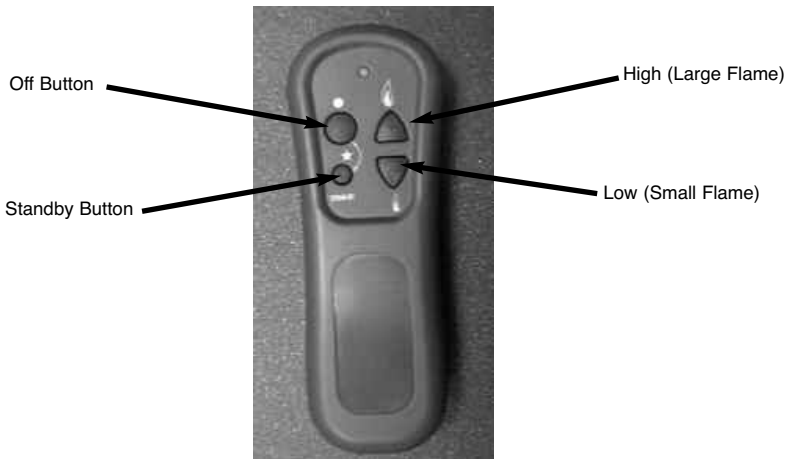

**WARNING : If the fire goes out for any reason or is turned off and it is necessary to re-light the fire it is important to allow the fire to cool for 3 minutes before attempting to re-light it.**

### 3.10 LIGHTING THE APPLIANCE - ELECTRONIC FIRE CONTROL MODELS.

- a) To light the fire using the electronic fire control, press the ignition button as indicated below in figure 30. The fire will emit a “beep” sound, the buttons can now be released. After a few seconds an audible clicking can be heard and then the fire will light the pilot and then light the main burner. The ignition cycle will take approximately 20 seconds.
- b) To reduce the level of heat input on the fire, press the small flame button on the trim switch. (An audible beep will be heard)
- c) To increase the level of heat input on the fire, press the large flame button on the trim switch. (An audible beep will be heard)
- d) To leave the fire in the standby mode (pilot only running) press the small round button on the trim switch. (An audible beep will be heard)
- e) To switch the appliance off completely, press the Ignition / Off button on the trim switch, the fire will then switch off. (An audible beep will be heard)

Fig. 30

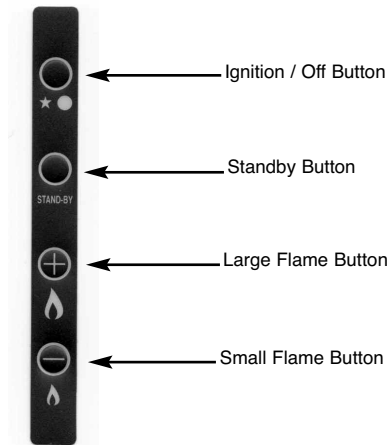

**WHEN TURNING THE FIRE “OFF” PLEASE ENSURE THAT THE PILOT FLAME IS EXTINGUISHED. DO NOT LEAVE THE PILOT FLAME ONLY LIT.**

**WARNING : If the fire goes out for any reason or is turned off and it is necessary to re-light the fire it is important to allow the fire to cool for 3 minutes before attempting to re-light it.**



### 3.11 CHECKING FOR CLEARANCE OF COMBUSTION PRODUCTS

- a) Close all doors and windows in the room.
- b) Light the fire and allow to run for approximately 5 minutes on high position.
- c) After approximately 5 minutes hold a smoke match 10mm inside and below the centre of the lower front edge of the top of the fire as shown overpage in figure 32. (It is recommended that a suitable smoke match holder is used when checking for clearance of combustion products). The majority of smoke generated should be drawn back into the flue. If spillage occurs or if in doubt, repeat the test after a further 10 minutes. **If the test indicates that spillage is occurring and the flue restrictor baffle has been fitted, it should be removed and the test repeated after the fire has cooled. See figure 31 below for details of how to remove and re-fit the restrictor baffle.**
- d) If spillage persists with the restrictor baffle removed, the flue is not functioning correctly and a fault exists. If, after investigation the fault cannot be traced and rectified, the fire must be disconnected from the gas supply and expert advice obtained.
- e) If there is an extractor fan fitted any where in the vicinity of the appliance, the spillage test should be repeated with the fan running on maximum and all interconnecting doors open.

**Fig. 31**

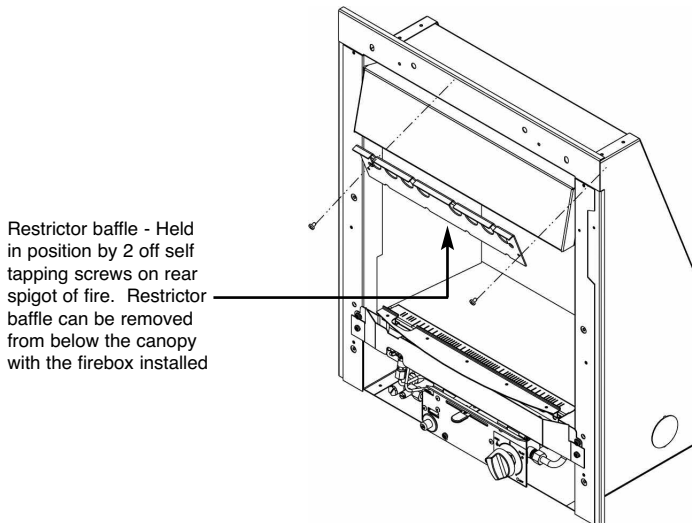

f) After ensuring that the fire is safe to use it should be left in the high position to fully warm up. During this time a slight odour may be noticed, this is due to the “newness” of the fire and will soon disappear.

At this stage any minor adjustments to the coals should be made using suitable long handled tongs and taking care not to damage the coals.

Finally, hand the Installation and Maintenance Instructions and the Users Instructions over to the customer and explain the operation of the fire.

**Fig. 32**

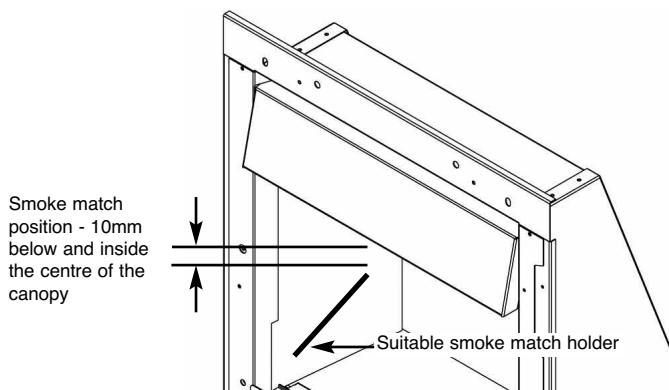

## SECTION 4 MAINTENANCE

### Servicing Notes

Servicing should be carried out annually by a competent person such as a GAS SAFE registered engineer. **This is a condition of the Kinder guarantee schemes.**

The service should include visually checking the chimney and fire opening for accumulations of debris and a smoke test to check for a positive up-draught in the chimney. The ODS must also be replaced as a condition of the guarantee.

The condition of the coals / pebbles should be checked and **if necessary the whole set should be replaced with a genuine replacement set.**

The burner assembly is designed to be removed as a complete unit for ease of access. **After any servicing work a gas tightness check must always be carried out.**

### Manual Control Fires – For Diagrams refer to Section 2

#### 4.1 Removing the burner assembly from the fire.

4.1.1 Prepare work area (lay down dust sheets etc.)

4.1.2 Remove the trim. Lift the fender and ash pan cover out of the way and put them in a safe location. Remove the loose coals / pebbles from the fuel bed and front ceramic rail. Remove the front ceramic from the rail. Unscrew the two pozi-driv fixing screws which secure the burner heat shield and remove it from the fire.

4.1.3 Isolate the gas supply and remove the inlet pipe from the appliance inlet elbow. Unscrew and remove the four screws which retain the burner. Remove the burner assembly from the fire.

4.1.4 To refit the burner assembly. Push the base of the control panel fully into the fire and secure with the four screws. Refit the gas supply pipe and carry out a gas tightness test. Refit the burner heat shield then refit the coals / pebbles referring to section 3 for the correct coal layout. The fender and ash pan cover can now be re-positioned. Refit the trim.

#### 4.2 Removing the Piezo Igniter

4.2.1 Remove the burner assembly as in section 4.1

4.2.2 Disconnect the ignition lead from the piezo and unscrew the retaining nut on the rear of the control panel. Withdraw the piezo from the front of the control panel. Reassemble in reverse order and carry out a gas tightness test.

### **4.3 Removing the Control Tap from the fire.**

- 4.3.1 Remove the burner assembly as in section 4.1.
- 4.3.2 Pull the control knob off the control tap spindle.
- 4.3.3 Loosen and remove the three gas pipe retaining nuts from the control tap and release the ends of the gas pipes from the control tap body. Loosen and remove the thermocouple securing nut from the end of the control tap.
- 4.3.4 Unscrew the control tap locknut from the front of the control panel and remove the control tap.
- 4.3.5 To refit a control tap, reassemble in reverse order noting that the control tap locates with a flat in the control panel. Carry out a gas tightness test after re-assembly.

### **4.4 Removing the Oxy-Pilot Assembly**

**Note : Because this appliance is fitted with an atmosphere sensing ‘Oxy-Pilot’ it is not possible to replace the thermocouple separately, because the thermocouple position is factory set to a tight tolerance. Any replacement of parts on the pilot requires a complete new pilot assembly.**

- 4.4.1 Remove the burner assembly as in section 4.1
- 4.4.2 Unscrew and remove the thermocouple retaining nut from the end of the control tap and disconnect the ignition lead from the pilot electrode.
- 4.4.3 Unscrew and remove the two pozi-driv screws which secure the pilot assembly to the burner. Remove the pilot.
- 4.4.4 Re-assemble in reverse order and carry out a gas tightness test.

### **Slide Control Models – For Diagrams refer to Section 2**

#### **4.5 Removal of the burner assembly**

- 4.5.1 Prepare the work area (lay down dust sheets etc,)
- 4.5.2 Remove the trim. Lift the fender and ash pan cover out of the way and put them in a safe location. Remove all of the loose coals / pebbles and front ceramic rail. Unscrew the two pozi-drive fixing screws which secure the burner heat shield and remove it from the fire.

4.5.3 Isolate the gas supply and remove the inlet pipe from the appliance inlet elbow. The control lever operating cable can be seen running across the base of the fire, below the burner. To release the cable, unscrew the cable securing screw located in the centre of the aluminium operating arm and release the front part of the operating arm, thereby freeing the cable from the burner (see figure 27 overpage). Note the securing screw is retained in the block to prevent it from being lost. Release the other end of the cable by pushing the cable to the right, i.e. into the operating arm so as to release the tension. Remove the two retaining screws at the base of the burner unit, and the screw each side of the burner unit. The base of the burner unit can now be pulled forward, allowing the burner to be removed outwards and downwards from the fire box. Remove the burner assembly from the fire.

4.5.4 Refit the burner assembly to the firebox by carefully pushing the bottom of the burner back into position. Secure using the two screws into the side frame of the firebox, and two screws into the base.

It is now necessary to refit the operating arm front section to the rear section (reverse of procedure described above), when this is completed, move the control lever fully downwards and check that the left hand micro-switch operates the igniter and that the control valve spindle is fully depressed. Move the control lever upwards to the "off" position and check that the right hand (cut-off) micro-switch operates. Check that the control lever operates smoothly and safely. Refit the coals / pebbles as shown in section 3, refit the fender / ashpan cover and trim.

## **4.6 Removal of the battery ignitor**

4.6.1 Remove the burner assembly as above.

4.6.2 Disconnect the ignition lead and 2 off microswitch leads from the igniter. Unscrew the Battery retaining cap and place battery to one side. Then unscrew igniter retaining ring and remove igniter from panel. Re-assemble in reverse order and carry out a gas tightness test.

## **4.7 Replacing the battery**

4.7.1 Unscrew Battery retaining cap situated at the front right of the fire and remove the battery

4.7.2 Replace in the reverse order using a 1.5V AA Alkaline Battery.

## 4.8 Removing the Oxy-Pilot Assembly

**Note:** Because this appliance is fitted with an atmosphere sensing 'Oxy-Pilot' it is not possible to replace the thermocouple separately, because the thermocouple position is factory set to a tight tolerance. Any replacement of parts on the pilot requires a complete new pilot assembly.

- 4.8.1 Remove the burner assembly as in section 4.1
- 4.8.2 Unscrew and remove the thermocouple retaining nut from the end of the control tap, disconnect the ignition lead from the pilot electrode and the two inline leads from the microswitch.
- 4.8.3 Unscrew and remove the two pozi-drive screws which secure the pilot assembly to the burner. Remove the pilot.
- 4.8.4 Re-assemble in reverse order and carry out a gas tightness test.

## 4.9 Replacing the Control Cable

- 4.9.1 The control lever operating cable can be seen running across the base of the fire, below the burner. To release the cable, unscrew the cable securing screw located in the centre of the aluminium operating arm and release the front part of the operating arm, thereby freeing the cable from the burner. See figure 33 below.

**Fig. 33**

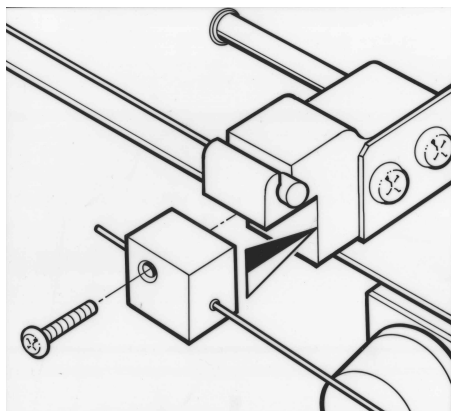

- 4.9.2 Hold the hexagonal control lever cable locking bush with a spanner and unscrew the locking screw using a 2mm allen key to release the cable from the control lever. The control cable can now be removed from the cable guide tubes.

- 4.9.3 To fit the replacement cable, thread the end of the new cable into the long length of p.t.f.e. sleeve (as supplied) , taking care not to kink the sleeve. Now carefully feed the sleeve and cable into the left hand cable guide tube until the ends emerge above the control lever. Now thread the short length of p.t.f.e. sleeve over the end of the cable and thread the sleeve and cable into the top of the short cable guide tube.
- 4.9.4 When the end of the cable emerges from the short cable guide tube, locate the nipple on the other end of the cable into the locating hole in the aluminium operating arm. Thread the free end of the cable into the cable retaining hole on the operating arm, but at this stage do not tighten the securing screw.
- 4.9.5 Fit the hexagonal control lever cable locking bush onto the control lever and fit the control cable loosely into the bush in the gap between the two lengths of p.t.f.e. sleeve. Ensure that the cable is located in the retaining hole in the locking bush and tighten the screw sufficiently to retain the cable but still allowing it to slide for adjustment.
- 4.9.6 It is now necessary to correctly tension the operating cable. To do this, first set the control lever to the horizontal (central position), this is the position which creates maximum tension in the operating cable. Pull the free end of the operating cable through the operating arm until it is finger tight and secure with screw into operating arm (do not over tighten).
- 4.9.7 Slide the operating arm fully to the right hand position and hold in position, slide the control lever relative to the cable until the cable retaining screw lines up with the hole in the flange. This sets the control lever in the correct position. Hold the hexagonal locking bush with a spanner and tighten the retaining screw using the 2mm allen key. Move the control lever fully downwards and check that the left hand micro-switch operates the igniter and that the control valve spindle is fully depressed. Move the control lever upwards to the "off" position and check that the right hand (cut-off) micro-switch operates. Check that the control lever operates smoothly and safely.

## **Remote & Electronic Fire Control Models – For Diagrams refer to Section 2**

### **4.10 Removing the burner assembly from the fire.**

- 4.10.1 Prepare work area (lay down dust sheets etc.)
- 4.10.2 Lift the fender and ash pan cover of the way and put them in a safe location. Remove the loose coals / pebbles from the fuel bed and front ceramic rail. Remove the front ceramic from the rail. Unscrew the two pozi-driv fixing screws which secure the burner heat shield and remove it from the fire.
- 4.10.3 Isolate the gas supply and remove the inlet pipe from the appliance inlet elbow. Unscrew and remove the four screws which retain the burner. Remove the HT lead from the Pilot electrode and remove the burner assembly from the fire, ensuring not to pull to tightly on the PCB wiring. Cut the cable tie from the remote infrared eye self adhesive pad, which will be situated on the hearth panel, flush with the front edge of the ashpan cover.
- 4.10.4 To refit the burner assembly. Ensure wiring is fitted correctly to the PCB assembly. Push the base of the control panel fully into the fire and secure with the four screws. Refit the gas supply pipe and carry out a gas tightness test. Refit the burner heat shield then refit the coals / pebbles referring to section 3 for the correct coal layout. On RC models the infrared eye must be cable tied back to the self adhesive pad which will be situated on the hearth panel. The fender and ash pan cover or can now be re-positioned.

### **4.11 Removing the Valve Assembly**

- 4.11.1 Remove the burner assembly as in section 4.10
- 4.11.2 Remove the thermocouple retaining nut from the valve. remove the main pipe, inlet pipe and pilot pipe from the valve.
- 4.11.3 Remove the valve retaining screws and remove. Re-assemble in reverse order and carry out a gas tightness test. Re-fit coals / pebbles as shown in section 3. The fender and ash pan cover can now be re-positioned.

### **4.12 Removing the Pilot Assembly.**

**Note : Because this appliance is fitted with an atmosphere sensing ‘Oxy-Pilot’ it is not possible to replace the thermocouple separately, because the thermocouple position is factory set to a tight tolerance. Any replacement of parts on the pilot requires a complete new pilot assembly.**



- 4.12.1 Remove the burner assembly as in section 4.1.
- 4.12.2 Unscrew the thermocouple retaining nut from the solenoid.
- 4.12.3 Loosen the pilot nut and remove two screw retaining the pilot assembly.
- 4.12.4 Re-assemble in reverse order and carry out a gas tightness test. Re-fit coals / pebbles as shown in section 3. The fender and ash pan cover can now be re-positioned.

#### **4.13 Replacing the Batteries (Within the Firebox)**

- 4.13.1 Remove the fender and ashpan assembly The battery holder is located on the right hand side of the appliance .
  - 4.13.2 Remove the battery pack with care and then disconnect the battery lead at the white rectangular plug and socket.
  - 4.13.3 Replace in reverse order and check correct operation of the appliance.
- NB The handset uses one LR61 (9v) and should be replaced by removing the cover on the rear of the handset.

#### **ENSURE THE BATTERIES ARE CONNECTED TO THE CORRECT POLARITY POSITIVE (+), NEGATIVE (-)**

#### **4.14 Removing the Trim Switch**

- 4.14.1 Remove the burner assembly as in section 4.10 and disconnect the trim switch cable from the control board.
- 4.14.2 Remove the trim switch from the mounting frame (held in position by self adhesive backing).
- 4.14.3 Re-connect to the wiring loom.
- 4.14.4 Replace in reverse order and carry out a gas tightness test.

## FRET INFORMATION

To enable Customers to choose their own style of fret these Kalahari models are now available without frets. In order to maintain the efficient and safe operation of the fire it is important that any fret which is used must comply with the following dimensions. (figure 34). It is important to clean a fret in accordance with the instructions provided by your retailer as these vary depending on the surface finish of the fret.

**Fig. 34**

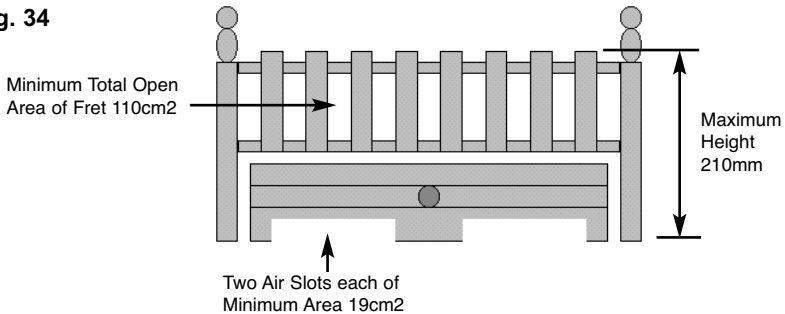

## PARTS SHORTLIST

Replacement of parts must be carried out by a competent person such as a GAS SAFE registered gas installer. The part numbers of the replaceable parts are as follows, these are available from BFM Europe who may be contacted at the address shown on the rear cover.

Kalahari complete coal / ceramic set	B-56970
Kalahari coal fuelbed base	B-56320
Kalahari coal fuelbed front rails (pair)	B-56330
Replacement coal set	B-56340
Complete Kalahari pebble / ceramic set	B-77250
Kalahari pebble fuelbed base	B-77260
Kalahari pebble fuelbed front rail	B-58140
Kalahari replacement pebble set	B-77250
Camber pebble / ceramic set	B-106420
Camber pebble fuel-bed matrix	B-106430
Camber pebble front rail	B-106440
Camber pebble set	B-106450
RC gas control valve	B-106790
RC control board	B-129140
RC battery cable	B-106810
RC battery holder	B-106820
Piezo igniter	B-1320
Ignition wire manual control models	B-39030
Ignition wires slide control models	B-50380
Ignition wire remote / EFC models	B-63650
Manual gas valve	B-102880
Slide gas valve	B-40980
Remote valve	B-106790

## SECTION FIVE - USER INSTRUCTIONS

### 5.1 INSTALLATION INFORMATION

#### CONDITIONS OF INSTALLATION

It is the law that all gas appliances are installed only by a competent (e.g. GAS SAFE registered) Installer, in accordance with the installation instructions and the Gas Safety (Installation and Use) Regulations 1998. Failure to install appliances correctly could lead to prosecution. It is in your own interest and that of safety to comply with the law.

The fire may be fitted below a combustible shelf provided that the shelf is at least 200mm above the top of the appliance and the depth of the shelf does not exceed 150mm.

The fire may be installed below combustible shelves which exceed 150mm deep providing that the clearance above the fire is increased by 15mm for each 25mm of additional overhang in excess of 150mm.

**No purpose made additional ventilation is normally required for this appliance when installed in G.B. When installed I.E. please consult document I.S. 813 : 1996 Domestic Gas Installation which is issued by the National Standards Authority of Ireland. Any purpose made ventilation should be checked periodically to ensure that it is free from obstruction.**

If the chimney or flue has been previously used by appliances burning fuels other than gas they must be swept prior to the installation of this fire.

If this appliance is fitted directly on to a wall without the use of a fireplace or surround, soft wall coverings such as wallpaper, blown vinyl etc. could be affected by the heat and hot convection air and may discolour or scorch. This should be considered when installing or decorating.

The Model number of this appliance is as stated on the rating plate affixed to the control panel of the fire and the appliance is manufactured by:-

BFM Europe Ltd  
Trentham Lakes  
Stoke on Trent  
ST4 4TJ

**Please Note : The life span of the batteries in the burner unit is dependent upon use and therefore the battery life will vary accordingly. If the burner unit fails to operate on slide, remote or electronic fire control models, please check the 1 off AA battery in slide control models or 6 off AA batteries in remote and electronic fire control model before calling the service centre for engineer assistance. Service calls as a result of flat batteries are chargeable.**

## **ABOUT YOUR NEW KINDER KALAHARI / CAMBER PLUS GAS FIRE**

The Kinder Kalahari / Camber plus coal / pebble effect gas fire incorporates a unique and highly developed fuel bed which gives the realism of a loose coal lay-out combined with realistic flames and glow. The use of durable ceramic material in the construction of the fuelbed components ensures long and trouble free operation. The fire incorporates a flame control (Kalahari Plus only) which allows you to adjust the flame appearance to give the desired combination of flames and glow. The left hand position gives maximum efficiency and output whereas the right hand position gives more flame but slightly less radiant glow.

When first using the new fire a slight smell may be noticed. This is due to starch used in the manufacture of the soft ceramic coals / pebbles, it is non-toxic and will soon disappear.

Please take the time to fully read these instructions as you will then be able to obtain the most effective and safe operation of your fire.

### **IMPORTANT SAFETY INFORMATION**

#### **WARNING**

**This appliance has a naked flame and as with all heating appliances a fireguard should be used for the protection of children, the elderly and infirm. Fireguards should conform to B.S. 8423 : 2002 (Fireguards for use with gas heating appliances).**

It is important that this appliance is serviced at least once a year by a GAS SAFE registered installer and that during the service the fire is removed from the fire opening and the chimney or flue visually checked for fallen debris or blockages which must be removed. The chimney should also be checked to ensure clearance of flue products.

**After installation or during servicing a spillage test must always be carried out.**

Rubbish of any type must NEVER be thrown onto the fuel bed, this could affect safe operation and damage the fire.

Any debris or deposits should be removed from the fuel bed from time to time. This may be carried out by referring to the cleaning section as described later in this book.

Only the correct number and type of coals / pebbles must be used and only complete and genuine replacement sets must be used.

Always keep furniture and combustible materials well clear of the fire and never dry clothing or items either on or near to the fire. Never use aerosols or flammable cleaning products near to the fire when it is in use.

**The ceramic fuel bed remains hot for a considerable period after use and sufficient time should be allowed for the fire to cool before cleaning etc.**

## 5.2 OPERATING THE FIRE - MANUAL CONTROL MODELS

The controls are located behind the ashpan cover which is situated behind the Ashpan / Fender. The controls, comprise a control valve to adjust the gas flow and a push button piezo igniter. There is also a flame adjuster which slides from left to right (Kalahari Plus models only). The left hand position gives maximum efficiency and output whereas the right hand position gives more flame but slightly less radiant glow. To light the fire proceed as follows:-

- a) Depress the control knob and turn anti-clockwise to the position marked pilot. Hold in the control knob for a few seconds to allow the gas to reach the pilot.
- b) Continue to hold-in the control knob and press the igniter button. If the pilot does not light, continue to press the igniter button until ignition occurs. The pilot flame's reflection can be seen by looking at the left hand side front of the stainless steel side trim. When the pilot has lit, continue to hold the control knob in for 5-10 seconds to allow the thermocouple to heat up, if the pilot goes out when the control knob is released, repeat the lighting sequence.

In the unlikely event of a failure of the igniter, the fire can be lit as follows :-  
Depress the control knob and turn anti-clockwise to the position marked pilot. Hold in the control knob for a few seconds to allow the gas to reach the pilot. Insert the tip of a lit taper in behind the front ceramic coals / pebbles on the left hand side. This will light the pilot flame. When the pilot has lit, continue to hold the control knob in for 5-10 seconds to allow the thermocouple to heat up, if the pilot goes out when the control knob is released, repeat the lighting sequence.

- c) After lighting, turn the control knob in the anti-clockwise direction to the high position and the main burner will light. It is recommended that for most efficient performance the fire is allowed to warm up for a few minutes with the flame adjuster set to the left hand position and the gas control on maximum.
- d) The gas control can be turned clockwise from the maximum position to give the desired heat output and the flame control adjusted to give the most pleasing flame effect or maximum efficiency and output.

**WARNING :** If the fire goes out for any reason or is turned off and it is necessary to re-light the fire it is important to allow the fire to cool for 3 minutes before attempting to re-light it.

### 5.3 OPERATING THE FIRE - SLIDE CONTROL MODELS

The controls comprise a control lever, to turn the fire on and off and adjust the gas rate, and a flame adjuster to alter the flame picture (Kalahari Plus models only).

The control lever is located at the top right hand side of the fire. Depressing the control lever fully operates the igniter and lights the pilot flame and ignition rate gas. Once the pilot is established raising the lever allows medium and finally high gas settings. The fire is turned off when the control lever is fully raised.

There is also a flame adjuster which slides from left to right. The left hand position gives maximum efficiency and output whereas the right hand position gives more flame but slightly less radiant glow. To light the fire proceed as follows :-

- a) Depress the control lever fully downwards to the position marked "Z". Hold down the control lever for a few seconds to allow the gas to reach the pilot.
- b) The fire will then begin its ignition sequence. If the pilot does not light, continue to press the control lever until ignition occurs. The pilot flame can be seen by looking underneath the front ceramic rail, above the burner heat shield, at the front left hand side of the fuel. When the pilot has lit, continue to hold the control lever down for 5-10 seconds to allow the thermocouple to heat up, before releasing the lever apply one firm downwards push to ensure that the f.s.d. valve is fully latched, if the pilot goes out when the control lever is released, repeat the lighting sequence.

In the unlikely event of a failure of the igniter, firstly check the operation of the 1.5V battery and if necessary replace with a 'AA' size alkaline battery.

**It is important that only an alkaline battery is used, otherwise premature battery failure and leakage may result.** If the appliance still fails to light the fire can be lit as follows :-

Depress the control lever fully downwards to the position marked "Z". Hold in position for a few seconds to allow the gas to reach the pilot. Insert the tip of a lit taper or spill between the front ceramic and burner heat shield. This will light the pilot flame and low rate gas. When the pilot has lit, continue to depress the control lever in for 5-10 seconds to allow the thermocouple to heat up before releasing the control lever apply one firm downwards push to ensure that the f.s.d. valve is fully latched.

- c) After lighting, move control lever up to the high position and the main burner will light. It is recommended that for the most efficient performance the fire is allowed to warm up for a few minutes with the flame adjuster set to the left hand position and the control lever set to high.
- d) The gas control can be moved from the High to Low position to give the desired heat output and the flame control adjusted to give the most pleasing flame effect or maximum efficiency and output.

- e) To turn the fire off, FULLY raise the control lever to the OFF position.

**WARNING : If the fire goes out for any reason or is turned off and it is necessary to re-light the fire it is important to allow the fire to cool for 3 minutes before attempting to re-light it.**

#### **5.4 OPERATING THE FIRE USING THE REMOTE CONTROL**

The controls comprise a remote control handset to ignite the fire and adjust the gas flow. There is also a flame adjuster located behind the ashpan cover which slides from left to right. (Kalahari Plus models only). The left hand position gives maximum efficiency and output whereas the right hand position gives more flame but slightly less radiant glow. The Remote control handset generates an infrared signal, which will be received by the sensor situated at the front of your fire, below the ashpan cover. This infrared signal requires direct line of sight from the handset to the sensor on the fire to ensure good operation. To light the fire proceed as follows:-

- a) To light the appliance using the handset, point the handset at the fire and press the 2 left hand buttons together. The fire will emit a “beep” sound, the buttons can now be released. After a few seconds an audible clicking can be heard and then the fire will light the pilot and then light the main burner. The ignition cycle will take approximately 20 seconds. It is recommended that for the most efficient performance the fire is allowed to warm up for a few minutes with the flame adjuster set to the left hand position and the input set to high.
- b) To reduce the level of heat input on the fire, point the handset at the fire and press the small flame button once. (An audible beep will be heard) and the heat input level will reduce to the low setting (4.2kW). Press and continually hold the small flame button and the fire will reduce incrementally to the low setting (4.2kW)
- c) To increase the level of heat input on the fire, point the handset at the fire and press the large flame button. (An audible beep will be heard) and the heat input level will increase to the high setting (6.9kW) Press and continually hold the small flame button and the fire will reduce incrementally to the high setting (6.9kW)
- d) To leave the fire in the standby mode (pilot only running) press the small round button on the handset. **The fire should not be left in the standby mode when unattended.**
- e) To switch the appliance off completely, press the large round button on the handset, the fire will then switch off. See figure 1 overpage for image of the handset.

**Fig. 1**

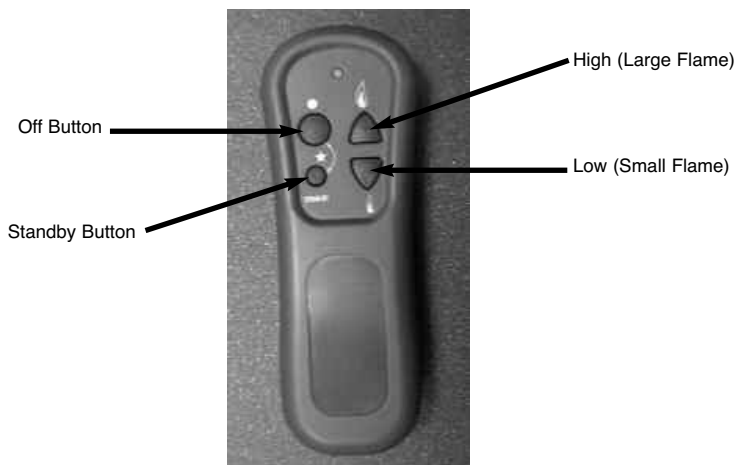

**WARNING :** If the fire goes out for any reason or is turned off and it is necessary to re-light the fire it is important to allow the fire to cool for 3 minutes before attempting to re-light it.

## **5.5 LIGHTING THE APPLIANCE - ELECTRONIC FIRE CONTROL MODELS**

- a) The controls comprise an electronic fire control (EFC) trim switch to ignite the fire and adjust the gas flow. The electronic fire control trim switch is located at the top right hand side of the fire. There is also a flame adjuster located behind the ashpan cover which slides from left to right. (Kalahari Plus models only). The left hand position gives maximum efficiency and output whereas the right hand position gives more flame but slightly less radiant glow. To light the fire proceed as follows:-  
To light the fire using the electronic fire control (trim switch), press the ignition button as indicated overpage in figure 2. The fire will emit a “beep” sound, the button can now be released. After a few seconds an audible clicking can be heard and then the fire will light the pilot and then light the main burner. The ignition cycle will take approximately 20 seconds. It is recommended that for the most efficient performance the fire is allowed to warm up for a few minutes with the flame adjuster set to the left hand position and the input set to high.
- b) To reduce the level of heat input on the fire, press the small flame button on the trim switch. (An audible beep will be heard)
- c) To increase the level of heat input on the fire, press the large flame button on the trim switch. (An audible beep will be heard)



- d) To leave the fire in the standby mode (pilot only running) press the small round button on the trim switch. (An audible beep will be heard). **The fire should not be left in the standby mode when unattended.**
- e) To switch the appliance off completely, press the Ignition / Off button on the trim switch, the fire will then switch off. (An audible beep will be heard)

**Fig. 2**

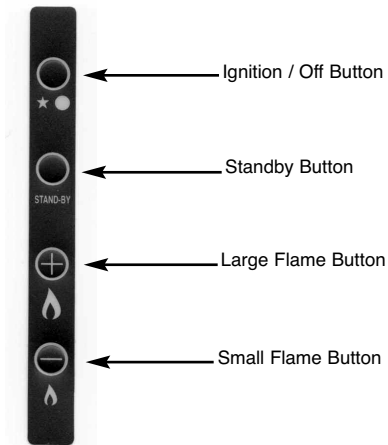

**WARNING :** If the fire goes out for any reason or is turned off and it is necessary to re-light the fire it is important to allow the fire to cool for 3 minutes before attempting to re-light it.

## 5.6 TURNING THE PRODUCT OFF IN THE UNLIKELY EVENT OF A REMOTE HANDSET OR EFC TRIM SWITCH MALFUNCTION.

- a) In the unlikely event of the remote control handset or EFC trim switch malfunctioning (or if lost or broken) after the appliance has been turned on, the fire can be turned off via the emergency shut off switch on the control panel.
- b) To turn the product off, firstly remove the ashpan from the fire.
- c) Press and hold the emergency shut off switch until the fire shuts down. The process may take up to sixty seconds to complete. (see figure 3 below).
- d) When the fire has shut down, release the emergency shut off switch.
- e) The appliance will now remain in the "off" position until activated by the remote handset / EFC trim switch (whichever is applicable).

**Fig. 3**

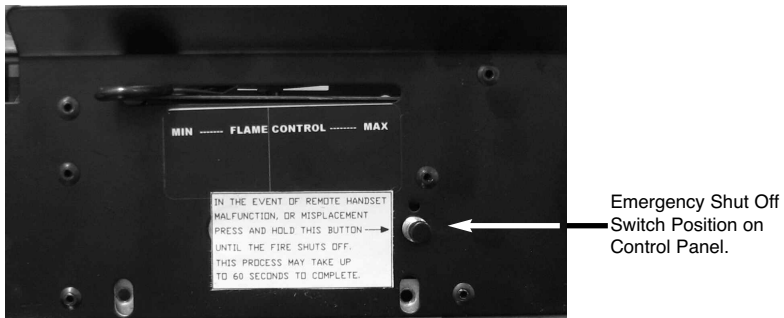

## 5.7 REPLACING THE BATTERIES - REMOTE CONTROL / ELECTRONIC FIRE CONTROL MODELS

- a) Remove the ashpan cover
- b) The battery pack is located on the right hand side side of the burner unit at the bottom.
- c) Carefully remove the pack and remove the batteries.
- d) Replace in the reverse order using 6 off 1.5V AA Alkaline Battery. **It is important that only an alkaline battery is used, otherwise premature battery failure and leakage may result.**

## 5.8 REPLACING THE BATTERY - SLIDE CONTROL MODELS

- a) Remove the ashpan cover
- b) The battery holder is located on the right hand side side of the burner unit at the bottom.
- c) Unscrew the retaining cap, remove and replace the battery then replace the retaining cap.

## 5.9 SPILLAGE MONITORING SYSTEM

All models regardless of control type are fitted with a spillage monitoring system which shuts down the fire if the evacuation of combustion products from the fire is affected by a partially or fully blocked flue. If this system operates the fire will go out. If this occurs, leave the fire for at least three minutes then follow the lighting procedure as described in the previous section. **In the event of repeated operation a GAS SAFE registered gas engineer must be called to investigate and rectify the cause.**

## 5.10 CLEANING - WARNING

Before attempting any cleaning operation ensure that the fire has been allowed to fully cool.

### CLEANING THE TRIMS AND PAINTED METAL PARTS

Dependent upon the trim option chosen for use with this fire, there is a variety of methods that can be chosen to clean the trim. If a Brass trim was supplied with this fire this is plated brass and this trim must only be cleaned using a clean damp cloth. Metal polishes must not be used on these trims. If a black trim was chosen, then these should only be cleaned using a clean, damp cloth also. The trim is best cleaned by removing it from the fire and placing it face up on a flat surface. The fender that was supplied with the fire is laquered to protect the finish and therefore must only be cleaned using a clean damp cloth.

**Abrasive cleaners, chemical cleaning agents or any type of polish must never be used as damage to the finish may result.**

### CLEANING THE FUEL BED

We do not recommend cleaning of coals / pebbles or fuelbed components as these are fragile and damage may result. **None of these parts must be washed or exposed to any cleaning agents or water.** Any damaged parts must be replaced by contacting your dealer or telephoning BFM Europe Ltd on the number stated on the rear cover of this book. Coals / pebbles must only be replaced with a complete and genuine replacement set and the fire must never be run with the wrong number or damaged coals. The fuelbed must be carefully re-assembled as stated in the following section.

## 5.11 ASSEMBLING FUEL BED & CERAMICS - COAL MODELS

- a) Place the ribbed ceramic fuelbed base on top of the fuelbed support and pull fully forwards to the burner. **Make sure that the fuelbed base is located centrally in the fire box. Ensure that the fuelbed base fit fully down onto the fuel bed support and is not lodged on the burner. See figure 4 below.**

Fig. 4



- b) Position the two halves of the front ceramic (L/H & R/H) on the locating channel in the front ceramic, ensuring it is located onto the lip on the burner front ceramic support. (See fig 5 below)

Fig. 5



- c) Fit five of the large sized coals onto the front ceramic rail, ensuring that they are evenly spaced. Use the recess's in the front ceramic rail as a guide for placement. (See figure 6 below)

**Fig. 6**



- d) Select four of the large coals and arrange behind the front row of coals, ensuring that flame paths as indicated below are not interrupted. Select two of the small coals and place at each end of the second row. (See figure 7 below)

**Fig. 7**

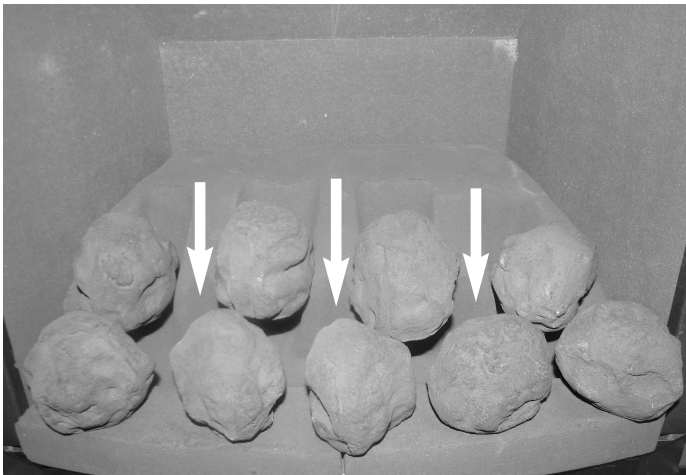

- e) Select three of the large coals and arrange along the rear of the fuelbed, using the ribs in the rear of the fuelbed as a guide for placement. (See figure 8 below)

**Fig. 8**



- f) Select two small coals and position to fill the gaps at each end of the third row of coals, as shown. (See figure 9 below).

**Fig. 9**

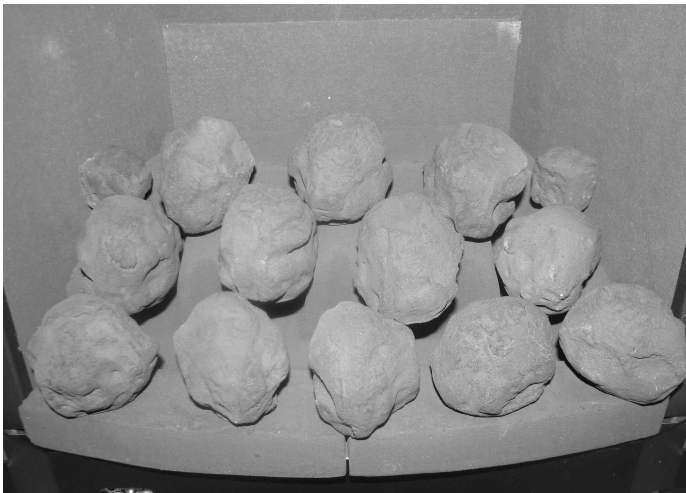

- g) Select the remaining four large coals and position on the rear of the fuel-bed matrix. (See figure 10 below).

**Fig. 10**

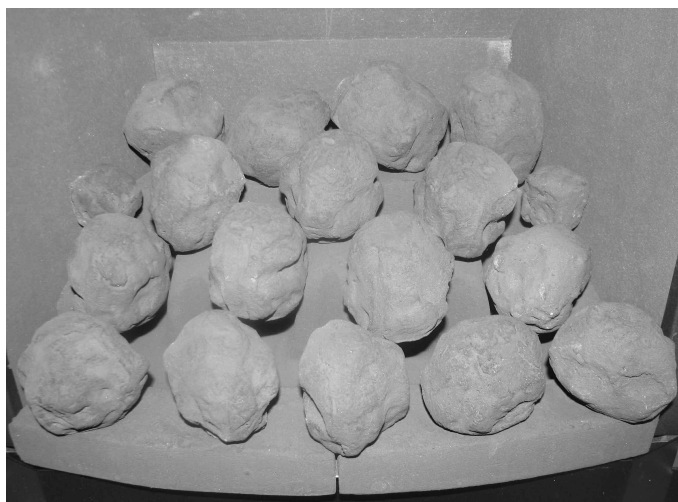

The exact position and fit of the coals may be finely adjusted to give the most pleasing and random appearance.

**Warning : Use only the coals supplied with the fire. When replacing the coals remove the old coals and discard them. Fit a complete set of coals of the correct type. Do not fit additional coals or any coals other than a genuine replacement set.**

This appliance uses fuel effect pieces containing Refractory Ceramic Fibres (R.C.F.), which are man-made vitreous silicate fibres. Excessive exposure to these materials may cause temporary irritation to eyes, skin and respiratory tract. Consequently, it makes sense to take care when handling these articles to ensure that the release of dust is kept to a minimum. To ensure that the release of fibres from these R.C.F. articles is kept to a minimum, during installation & servicing we recommend that you use a HEPA filtered vacuum to remove any dust and soot accumulated in and around the fire, before and after working on the fire. When replacing these articles we recommend that the replaced items are not broken up, but are sealed within a heavy duty polythene bag, clearly labelled as "RCF waste". This is not classified as "hazardous waste" and may be disposed of at a tipping site licensed for the disposal of industrial waste. Protective clothing is not required when handling these articles, but we do recommend you follow the normal hygiene rules of not smoking, eating or drinking in the work area, and always wash your hands before eating or drinking. This appliance does not contain any component manufactured from asbestos or asbestos related products.



## 5.12 ASSEMBLING THE CERAMICS AND FUEL BED - PEBBLE MODELS

- a) Place the ribbed ceramic fuelbed base on top of the fuelbed support and pull fully forwards to the burner. **Make sure that the fuelbed base is located centrally in the fire box. Ensure that the fuelbed base fit fully down onto the fuel bed support and is not lodged on the burner. (See figure 11 below).**

Fig. 11

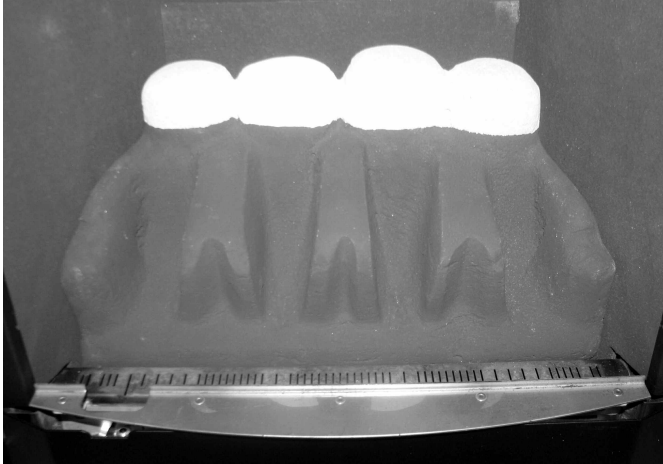

- b) Position front ceramic rail on burner front ceramic support and ensure that the locating channel in the front ceramic rail is correctly located onto the lip on the burner front ceramic support. (See figure 12 below).

Fig. 12

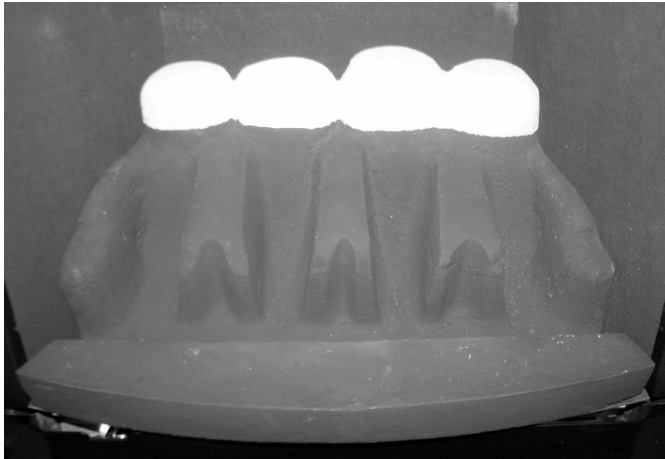

- c) Pick pebbles A to E and arrange along the the front rail, ensuring that they are evenly spaced. Use the recess's in the front ceramic rail as a guide for placement. (See figure 13 below).

**Fig. 13**

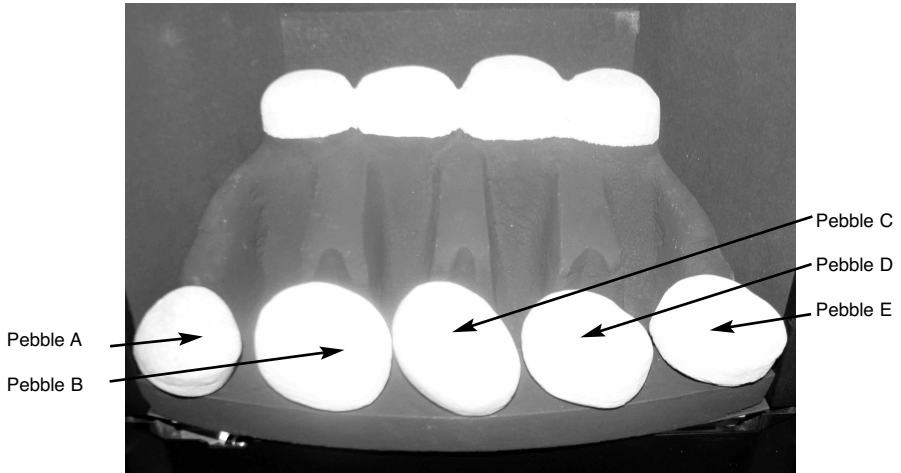

- d) Select pebbles F to I and arrange behind the front row of pebbles, ensuring that flame paths as indicated below are not interrupted. (See figure 14 below)

**Fig. 14**

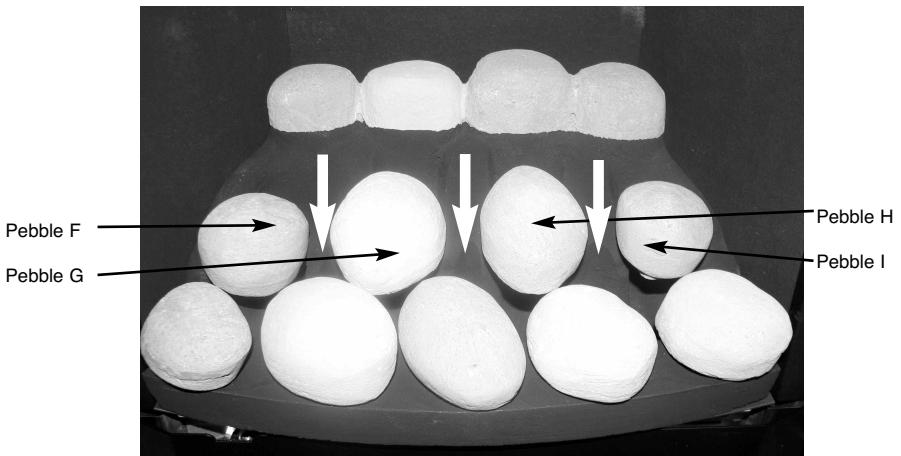

- e) Select pebbles K, L & M and arrange along the rear of the fuelbed, using the ribs in the rear of the fuelbed as a guide for placement. Select the two small pebbles (J & N) and position to fill the gaps at each end of the third row of pebbles (See figure 15 below).

**Fig. 15**

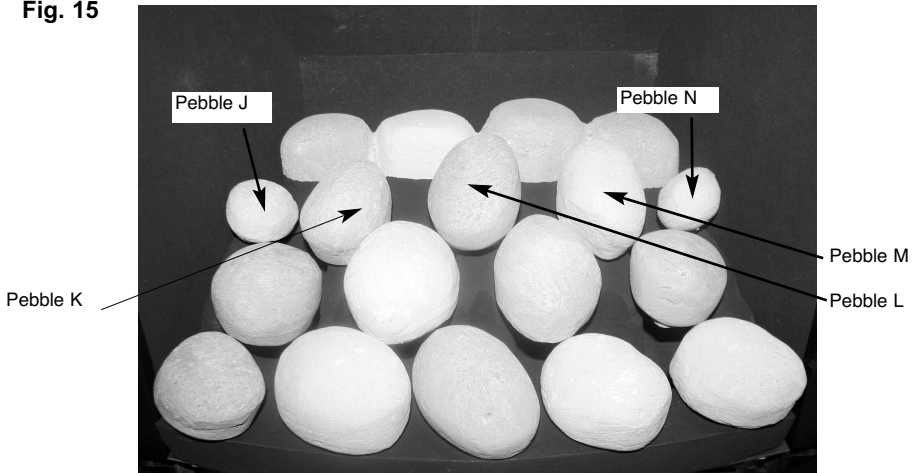

The exact position and fit of the pebbles may be finely adjusted to give the most pleasing and random appearance.

**Warning : Use only the pebbles supplied with the fire. When replacing the pebbles remove the old pebbles and discard them. Fit a complete set of pebbles of the correct type. Do not fit additional pebbles or any pebbles other than a genuine replacement set.**

This appliance uses fuel effect pieces containing Refractory Ceramic Fibres (R.C.F.), which are man-made vitreous silicate fibres. Excessive exposure to these materials may cause temporary irritation to eyes, skin and respiratory tract. Consequently, it makes sense to take care when handling these articles to ensure that the release of dust is kept to a minimum. To ensure that the release of fibres from these R.C.F. articles is kept to a minimum, during installation & servicing we recommend that you use a HEPA filtered vacuum to remove any dust and soot accumulated in and around the fire, before and after working on the fire. When replacing these articles we recommend that the replaced items are not broken up, but are sealed within a heavy duty polythene bag, clearly labelled as "RCF waste". This is not classified as "hazardous waste" and may be disposed of at a tipping site licensed for the disposal of industrial waste. Protective clothing is not required when handling these articles, but we do recommend you follow the normal hygiene rules of not smoking, eating or drinking in the work area, and always wash your hands before eating or drinking. This appliance does not contain any component manufactured from asbestos or asbestos related products.

## USER REPLACEABLE PARTS

The only user replaceable parts on this fire are the fuelbed components and coals / pebbles which may be replaced as described in the above section. Replacement of any other parts must be carried out by a competent person such as a GAS SAFE registered gas installer.

The part numbers of the user replaceable parts are as follows, these are available from BFM Europe Ltd whose contact details may be found overpage.

Kalahari complete coal / ceramic set	B-56970
Kalahari coal fuelbed base	B-56320
Kalahari coal fuelbed front rails (pair)	B-56330
Replacement coal set	B-56340
Complete Kalahari pebble / ceramic set	B-77250
Kalahari pebble fuelbed base	B-77260
Kalahari pebble fuelbed front rail	B-58140
Kalahari replacement pebble set	B-77250
Camber pebble / ceramic set	B-106420
Camber pebble fuel-bed matrix	B-106430
Camber pebble front rail	B-106440
Camber pebble set	B-106450

Due to our policy of continual improvement and development the exact accuracy of illustrations and descriptions contained in this book cannot be guaranteed

**Part No. B-151740**  
**Issue 3**

**K i n d e r**

FIRES FOR LIFE

BFM Europe Ltd.  
Trentham Lakes  
Stoke-on-Trent  
Staffordshire  
ST4 4TJ

[www.bfm-europe.com](http://www.bfm-europe.com)

**Telephone - General Enquiries :**  
**Telephone - Service :**

**(01782) 339000**  
**(0844) 7700169**