

CRYSTAL FIRES

1 BECHERS DRIVE
AINTREE RACECOURSE
BUSINESS PARK
AINTREE
LIVERPOOL
L9 5AY

CRYSTAL GEM

DECORATIVE FUEL EFFECT GAS FIRE

THIS APPLIANCE IS CATEGORY I_{2H} FOR USE
WITH NATURAL GAS AT A SUPPLY
PRESSURE OF 20 mbar OR CATEGORY I_{3P}
FOR USE WITH PROPANE AT A SUPPLY
PRESSURE OF 37mbar
G.B. AND I.E.

INSTALLATION & SERVICING BOOK

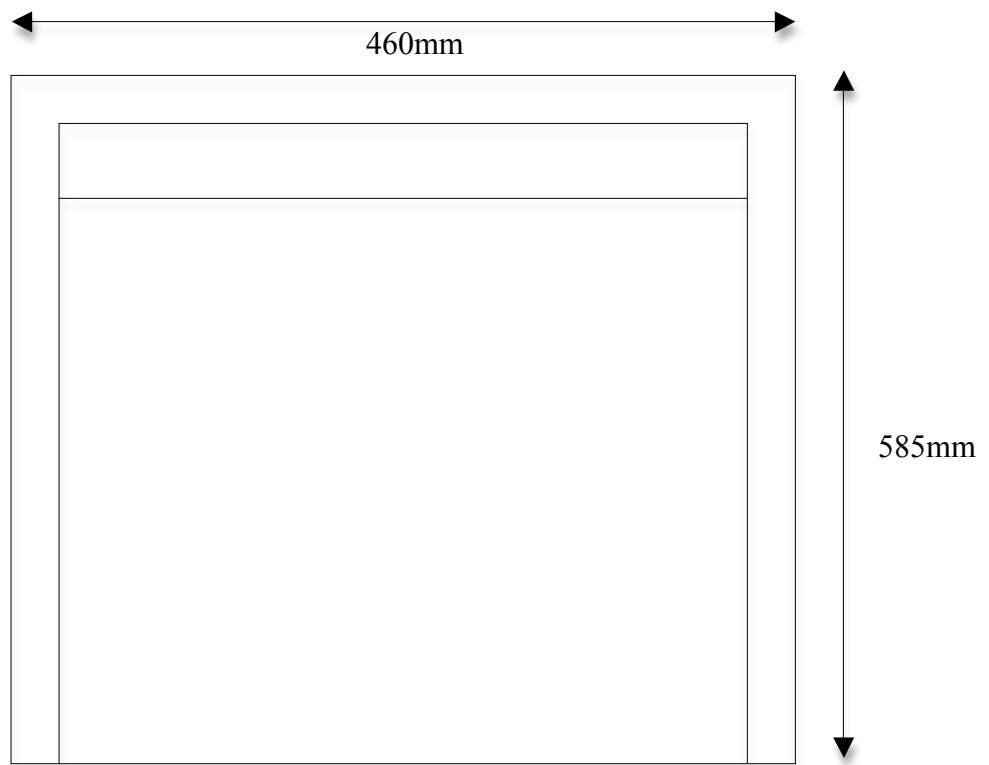
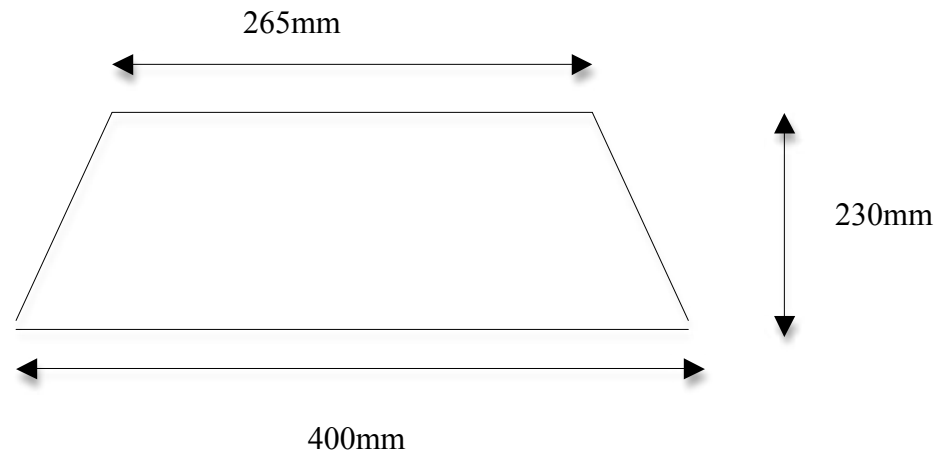

GEM BOX SIZES NOT INCLUDING TRIMS

PLEASE READ THESE INSTRUCTIONS CAREFULLY BEFORE YOU START INSTALLING THE APPLIANCE.
KEEP THIS BOOKLET HANDY FOR FUTURE REFERENCE

TECHNICAL DATA

GAS TYPE:	NATURAL GAS	PROPANE
GAS PRESSURE:	20mbar	37mbar
CONNECTION	8mm TUBE	8mm TUBE
INJECTOR:	CAT 82/440	CAT 92/160
REMOTE CONTROL	CAT 82/460	CAT 92/160
HEAT INPUT	6.9kW HIGH 4.1kW LOW	5.4kW HIGH 2.9kW LOW

DATA BADGE ON FRONT BOTTOM SECTION OF APPLIANCE

IMPORTANT NOTES

THIS APPLIANCE IS FITTED WITH AN ATMOSPHERE SENSING DEVICE AND CAN ONLY BE FITTED IN CONJUNCTION WITH THE FOLLOWING FLUES.

CONVENTIONAL BRICK OR STONE CHIMNEY.

OR A METAL FLUE BOX CONFORMING TO BS715

A NON COMBUSTIBLE HEARTH MUST BE PROVIDED TO COMPLY WITH THE BUILDING REGULATIONS OR A SUITABLE PROPRIETARY FIRE SURROUND WITH 100 DEGREES C RATING.

THE CHIMNEY OR FLUE (UNLESS NEW) MUST BE SWEEPED BEFORE INSTALLATION, IF IT HAS BEEN USED FOR SOLID FUEL

INSTALLER

THIS APPLIANCE MUST BE INSTALLED BY A COMPETENT PERSON

IE. A REGISTERED INSTALLER IN ACCORDANCE WITH THE CURRENT EDITION OF THE GAS SAFETY (INSTALLATION AND USE) REGULATIONS OR THE RULES IN FORCE. FAILURE TO DO SO COULD LEAD TO PROSECUTION.

VENTILATION GREAT BRITAIN

NO SPECIAL VENTILATION BRICKS OR VENTS ARE NORMALLY REQUIRED INTO THE ROOM CONTAINING THE APPLIANCE, PROVIDED NORMAL ADVANTAGEOUS ROOM VENTILATION EXISTS, THE INSTALLER MUST SATISFY THIS POINT BY A MANDATORY SPILLAGE TEST.

IRELAND. PURPOSE PROVIDED VENTILATION MUST BE PROVIDED AND MUST HAVE A MINIMUM FREE AREA OF 100CM²

WARNING

THIS APPLIANCE HAS A NAKED FLAME, AS WITH ALL SUCH FIRES IT IS RECOMMENDED THAT A FIREGUARD SHOULD BE USED FOR THE PROTECTION OF CHILDREN, THE ELDERLY AND INFIRM. FIRE GUARDS SHOULD CONFORM TO BS8423 2002 (FIREGUARDS FOR FIRES AND HEATING APPLIANCES FOR DOMESTIC USE-SPECIFICATION)

INSTALLATION REQUIREMENTS

CONVENTIONAL CHIMNEY

A CONVENTIONAL BRICK OR STONE CHIMNEY AS USED FOR SOLID FUEL APPLIANCE WITH A MINIMUM EFFECTIVE CROSS SECTIONAL DIMENSION OF 225*225mm, WITH A MINIMUM OF 3 METERS EFFECTIVE HEIGHT.

A LINED FLUE WITH A MINIMUM DIAMETER OF 125mm WITH THE FIREPLACE COMPONENTS CONFORMING TO BS 1251

A BUILDERS OPENING A MINIMUM OF 560mm HIGH AND 400mm WIDE WITH A MINIMUM DEPTH OF 260mm TO ALLOW SUFFICIENT VOLUME OF DEBRIS COLLECTION. TO OBTAIN THIS DEPTH IT IS NECESSARY TO REMOVE THE CHAIRBRICK.(EXCEPT WHEN INSTALLING FIRETRAY ONLY)
ANY PERMANENT FLUE RESTRICTION OR VARIABLE DAMPER MUST BE REMOVED OR LOCKED FULLY OPEN.

THE CHIMNEY MUST BE SWEEPED PRIOR TO INSTALLATION IF NOT NEW.

THE CHAIRBRICK MUST BE REMOVED ON ALL INSTALLATIONS.

EXCEPT WHEN INSTALLING FIRETRAY ONLY

WHEN INSTALLING FIRETRAY THE FOLLOWING HEARTH AND HEIGHT DIMENSIONS MUST BE ADHERED TOO

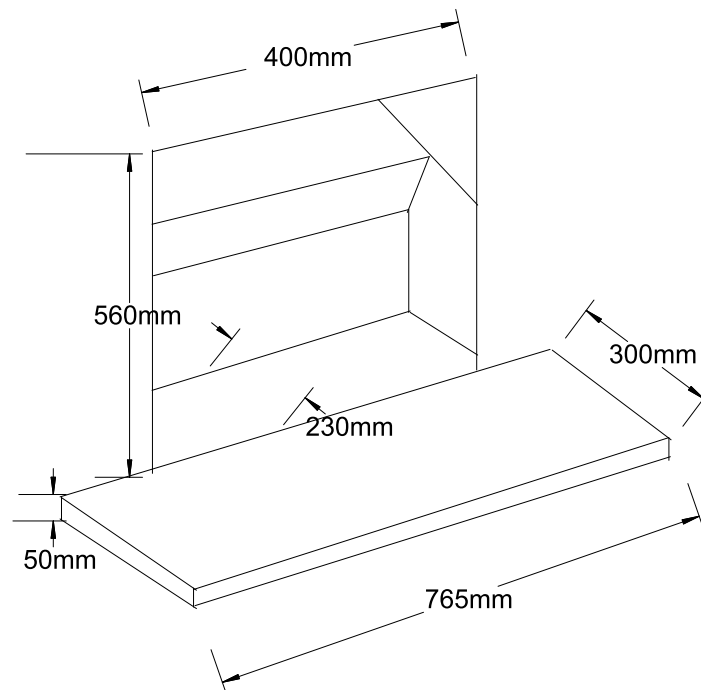

fig 2

INSTALLATION REQUIREMENTS FIRETRAY ONLY

THE GEM FIRETRAY MAY BE INSTALLED INTO A STANDARD FIREBACK OR HOT BOX INSTALLED WITH A CERAMIC FIRE BACK OR HOLE IN THE WALL FIREPLACE WHERE THE OPENING HEIGHT DOES NOT EXCEED 560mm (ie sunrise gas appliance)

THE INSTALLATION MUST ADHERE TO OPENING SIZES IN FIG 2

THE RELEVANT BRITISH STANDARDS MUST BE FOLLOWED

BS EN 1856

BS 5871 :PART 3

BS 5440: PART 1 AND 2

BS 6891

BS 8303

BS 1251

AND I.S 813 FOR IRELAND

FIRE TRAY SIZES NOT INCLUDING CERAMICS

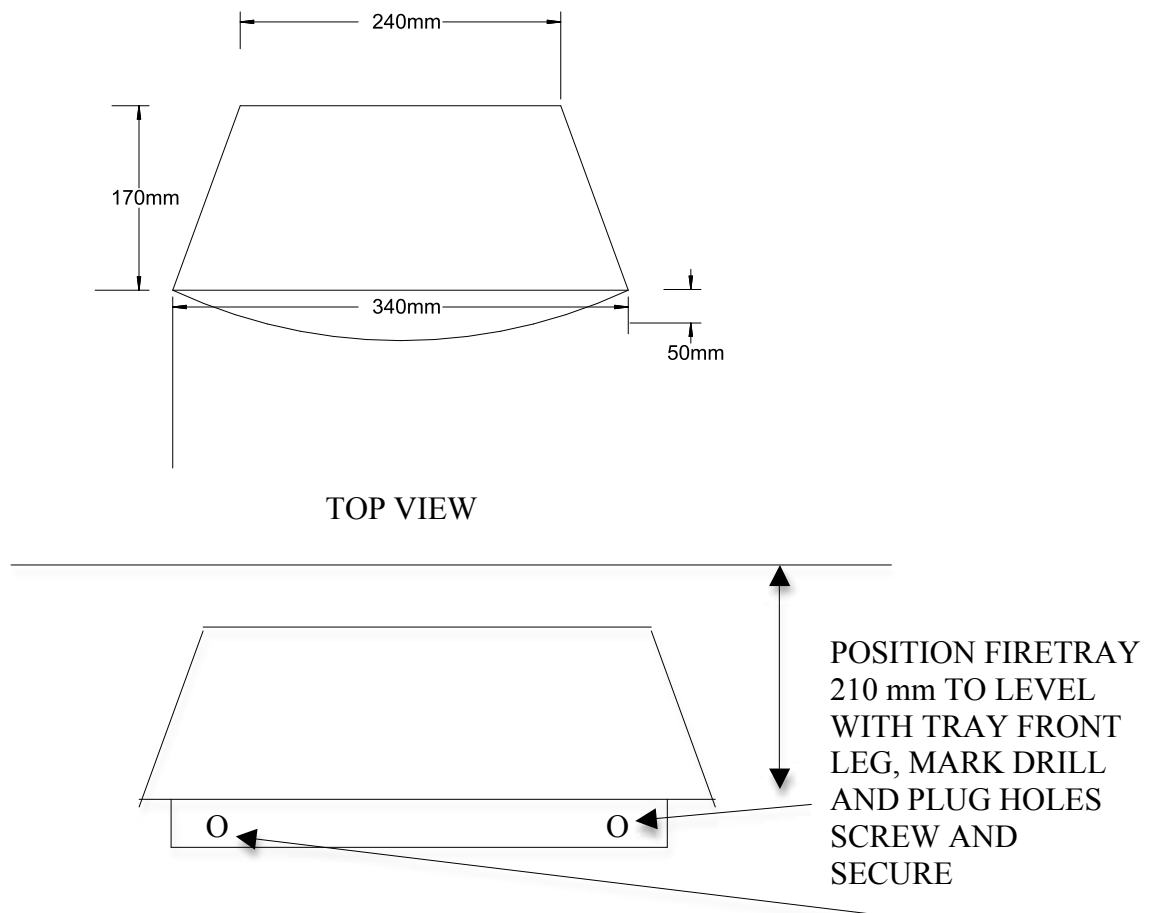

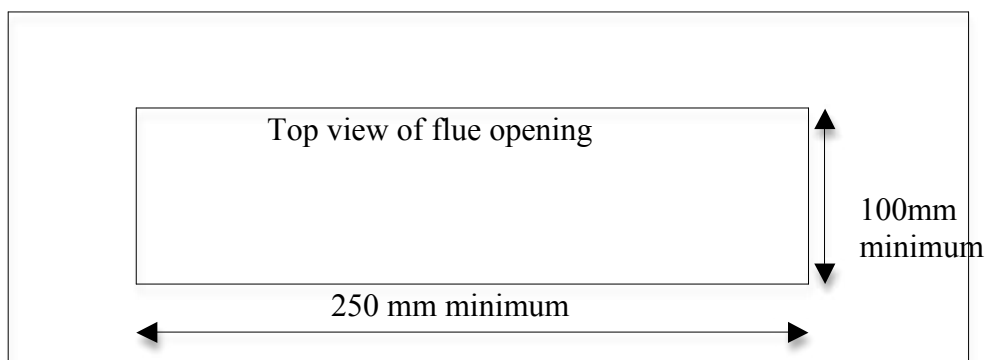
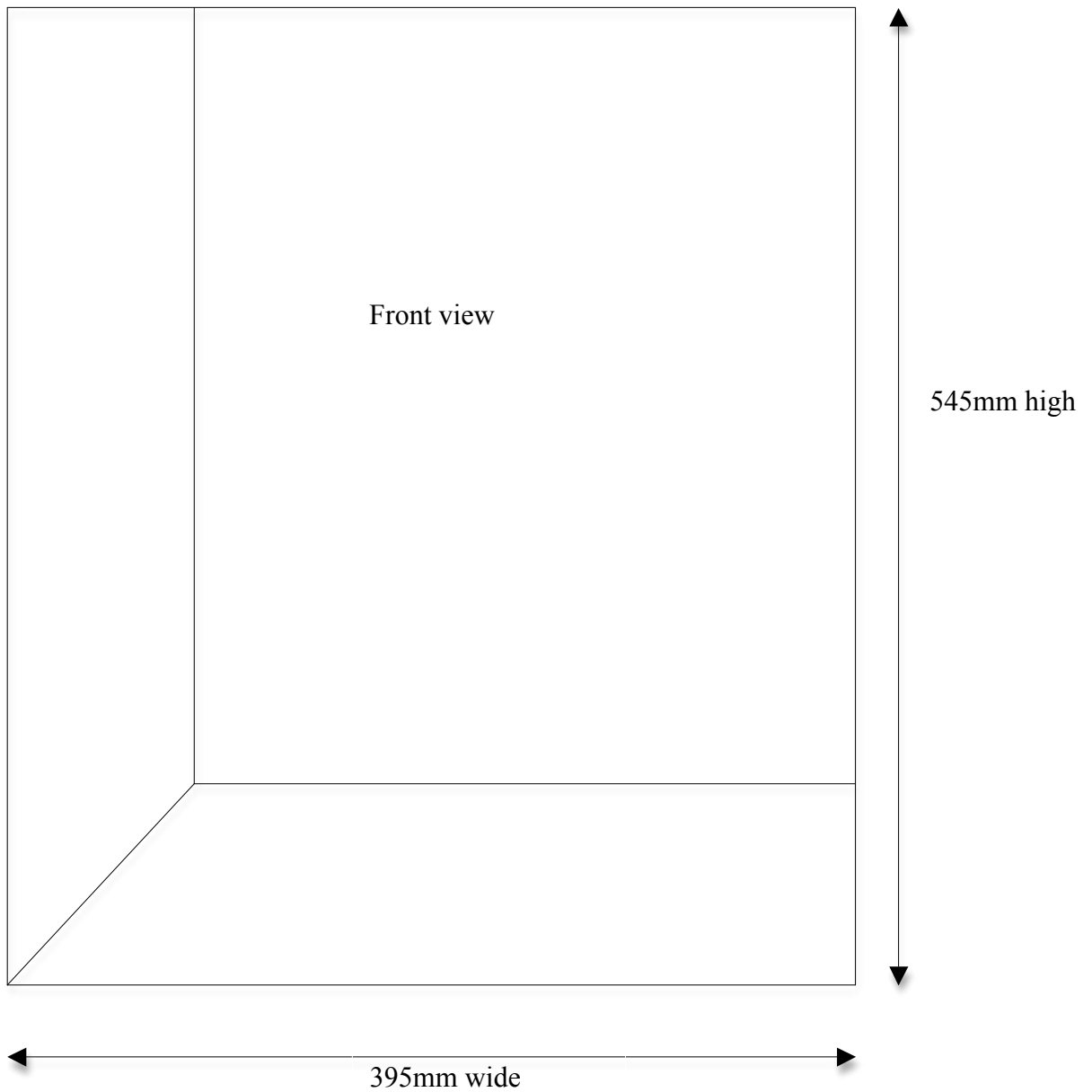

**A CERAMIC FIREBACK TO BS1251 INSTALLED IN A METAL BOX ,CAN BE USED AS A HOTBOX TO HOUSE THE GEM FIRETRAY
MUST BE TO THE DIMENSIONS SHOWN ABOVE**

INSTALLATION REQUIREMENTS

5 " FLUE PIPE AND STARTER BOX

A DOUBLE WALLED SELKIRK RECESSED FLUE BOX BUILT TO THE REQUIREMENTS OF BS 715 OR BS EN 1856 WITH AN INSULATED FLUE HAVING A MINIMUM DIAMETER OF 125mm (5") AND A MINIMUM EFFECTIVE OVERALL HEIGHT OF 3 METRES (10ft)

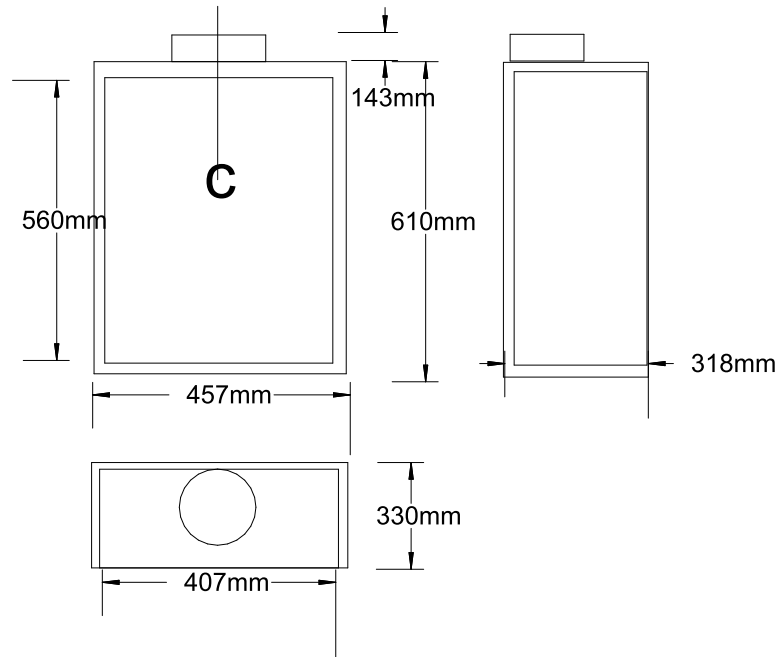

RECESSED GAS FLUE BOX DIMENSIONS (NOT INCLUDING FIBREGLASS INSULATION)

NOTE

THE METAL FLUE BOX MUST BE INSULATED WITH FIBRE GLASS OR EQUIVALENT TO A THICKNESS OF 25 mm.

NOTE

WHERE INSTALLATION IS FOR A METAL FLUE BOX, THE SURROUND MUST HAVE A TEMPERATURE RATING OF 150 DEGREES C .

NOTE

IF THE FLUE BOX IS TO BE USED WITH AN EXISTING BRICK OR STONE CHIMNEY A 125 mm (5") MINIMUM DIAMETER FLUE LINER CONFORMING TO BS 715 MAY BE USED.

NOTE

A BRICK CHAMBER TO THE SIZES IN FIG 2 IN AN EXISTING BRICK OR STONE CHIMNEY A 125mm MINIMUM DIAMETER FLUE LINER CONFORMING TO BS EN 1856 MAY BE USED, PROVIDING IT IS SEALED AT THE TOP AND BOTTOM OF THE EXISTING BRICK OR STONE CHIMNEY.

NOTE

ANY OF THE ABOVE FLUES MUST NOT BE RESTRICTED BY DAMPERS OR REGISTER PLATES, THE FLUE MUST SERVE ONLY ONE APPLIANCE AND NOT HAVE ANY BRANCHES OR TRAPS WHICH MAY IMPEDE THE NATURAL DRAUGHT .IF ANY TERMINAL IS FITTED IT MUST BE SUITABLE FOR THE PURPOSE.

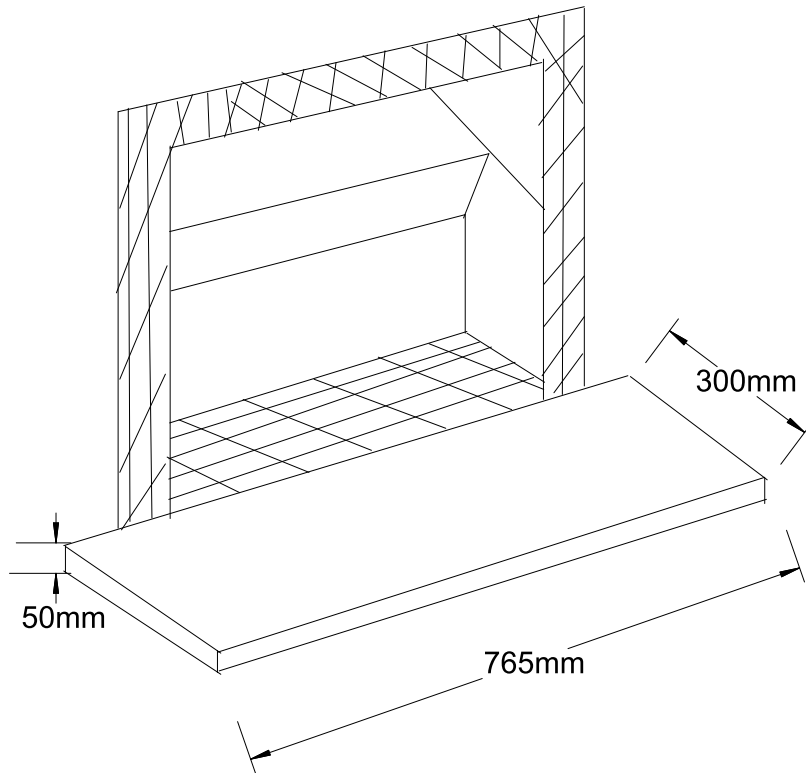

FIG 3

THE FRONT FACE SEAL MUST BE FLAT TO ENSURE A GOOD SEAL IS FORMED BETWEEN THE REAR AND BASE OF THE APPLIANCE AND CHIMNEY TO AVOID ANY REDUCTION IN THE NATURAL DRAUGHT.

ALWAYS ENSURE THE HEARTH IS LEVELED OFF TO HELP ENSURE NO NATURAL DRAUGHT IS LOST BELOW BASE (SEE FIG 3)

A NON COMBUSTIBLE HEARTH MUST BE PROVIDED BENEATH THE APPLIANCE WITHIN THE FIREPLACE OPENING.

A FIRE RESISTANT HEARTH MUST ALSO BE PROVIDED SYMMETRICALLY DISPOSED ABOUT THE FIREPLACE OPENING A MINIMUM THICKNESS OF 12mm WITH THE PERIMETER 50mm ABOVE THE FLOOR LEVEL

THE WIDTH MUST EXTEND A MINIMUM OF 150mm EITHER SIDE OF THE FIREPLACE OPENING AND A DEPTH OF 300mm FROM THE FUEL BED

ANY COMBUSTIBLE MATERIAL MUST BE REMOVED ABOVE THE OPENING TO A HEIGHT OF 900 mm ABOVE THE HEARTH LEVEL.

PURPOSE BUILT SUPERIMPOSED FIRE RESISTANT HEARTH AND BACK PANELS, SPECIFIED AS SUITABLE BY THE MANUFACTURERS MAY BE USED, OR A SUITABLE PROPRIETARY FIRE SURROUND WITH A 100 DEGREES C RATING.

CARE SHOULD BE TAKEN TO PREVENT ANY DAMAGE BEING CAUSED TO SURROUNDING SOFT FURNISHINGS OR DECORATION.

MANY EMBOSSED VINYL WALL COVERINGS MAY BECOME DISCOLOURED IF PLACE TOO CLOSE TO THE APPLIANCE

CHECK FLUE

CHECK THAT THE CHIMNEY CONFORMS TO THE REQUIRED SPECIFICATIONS AS

PREVIOUSLY STATED.

EXAMINE THE CONDITION AND CARRY OUT ANY REMEDIAL WORK

IF THE FLUE HAS BEEN USED FOR SOLID FUEL IT MUST BE SWEEPED AND A SMOKE TEST CARRIED OUT TO CHECK THAT SATISFACTORY SMOKE CLEARANCE HAS BEEN ESTABLISHED.

IF ALL THE SMOKE IS NOT DRAWN INTO THE FLUE , PRE HEAT THE FLUE WITH A BLOW TORCH OR SIMILAR AND RE CHECK, IF THERE IS ANY UNCERTAINTY EXAMINE FOR THE CAUSE AND IF NECESSARY SEEK EXPERT ADVICE.

GAS SUPPLY

IT IS RECOMMENDED A CONCEALED CONNECTION IS MADE USING SEMI RIGID TUBING ON THE LEFT SIDE OF THE APPLIANCE TAKING INTO ACCOUNT THE REQUIREMENTS OF BS 6891 1988 DEALING WITH ENCLOSED PIPES.

AN ISOLATING VALVE IS BUILT IN TO THE APPLIANCE AS PART OF THE PRESSURE TEST POINT ELBOW.

SECURE FIRE TO FIREPLACE

MARK POSITION OF FLANGE HOLES, DRILL AND PLUG AND FIX FIRE TO FIREPLACE ENSURING A GOOD SEAL USING FOAM SEAL SUPPLIED.

CHECKING GAS PRESSURE AND SOUNDNESS

REMOVE THE PRESSURE TEST POINT SCREW FROM THE INLET ELBOW AND CONNECT PRESSURE GAUGE.

TURN ON GAS TO APPLIANCE.

ROTATE THE CONTROL TO THE IGNITION POSITION AND PUSH IN TO ALLOW THE AIR IN THE PIPEWORK TO BE PURGED.

PUSH IN PIEZO IGNITION SWITCH

CHECK THAT THE ELECTRODE IS SPARKING.

CONTINUE SPARKING UNTIL PILOT IGNITION IS ESTABLISHED.

TURN THE GAS CONTROL KNOB ON TO THE HIGH POSITION AND ALLOW TO RUN FOR FIVE MINUTES.

CHECK THE INLET PRESSURE IS 20 MBAR. +/- 1MBAR ON NATURAL GAS OR 37 mbar ON PROPANE

CHECK FOR GAS SOUNDNESS.

TURN OFF GAS SUPPLY, DISCONNECT PRESSURE GAUGE AND REPLACE PRESSURE TEST POINT SCREW.

COAL BED LAYOUT

PERIODICALLY SMALL DEPOSITS OF SOOT MAY GATHER ON THE FUEL BED AND BURNER, THIS MUST BE REMOVED BY REMOVING FUEL AND BRUSHING ANY DEPOSITS WITH A SOFT BRUSH AND VACUUMING THE BURNER, THEN REPLACE FUEL USING THE FOLLOWING PROCEDURE.

THE MAIN FIBRE BASE IS LIABLE TO HAVE SURFACE CRACKS DUE TO THE HIGH TEMPERATURES OF THE FIBRE AND THE PAINT BEING DIFFERENT THIS IS QUITE NORMAL AND SHOULDN'T CAUSE CONCERN



Main ceramic matrix sits on back base central



Front piece sits in to well of burner and flat onto the curved front of fire tray
Flat and stable



Piece marked underneath 1 sits snugly above front piece
central and touching left side and right



The rear piece can be fitted to the top
Sitting central and behind the coal pieces on the
side matrix.
Sitting flat



Piece marked underneath 2 sits flat centrally above
piece 1 onto the flat ledge on the main matrix
Piece 2 should not be touching piece 1 and there
should be a gap of approx 5mm



Final piece marked underneath 3 sits on top of
piece 2 and to the rear pieces
This piece should not actually touch the rear
piece and there should be a gap of approx 5 mm

THE EFFECT CAN ALSO COME AS PEBBLES THE LAYOUT IS EXACTLY THE SAME AS ARE
THE PIECES HOWEVER THE TOP EFFECT LOOKS LIKE PEBBLES RATHER THAN COAL.

TEST FOR SPILLAGE

CHECK FOR SATISFACTORY CLEARANCE OF COMBUSTION PRODUCTS
CLOSE ALL DOORS AND WINDOWS IN THE ROOMS CONTAINING THE FIRE
TURN ON GAS FIRE AND SET THE CONTROL TO HIGH
LEAVE THE FIRE BURNING FOR FIVE MINUTES AND INSERT A LIGHTED SMOKE MATCH
ON A VERTICAL PLANE
50 mm DIRECTLY UNDER FRONT EDGE OF CANOPY AND 50mm FROM EITHER SIDE OF THE
OPENING
ALL SMOKE MUST BE DRAWN INTO THE FLUE
IF SPILLAGE OCCURS ALLOW A FURTHER TEN MINUTES
SHOULD SPILLAGE STILL OCCUR TURN OFF THE FIRE AND SEEK
EXPERT ADVICE
IF AN EXTRACTOR FAN IS SITUATED IN THE ROOM , THIS TEST SHOULD BE REPEATED
WITH THE FAN RUNNING
IF THERE IS A ROOM WITH AN EXTRACTOR FAN, THE TEST SHOULD BE REPEATED WITH
ALL THE DOORS TO THAT ROOM OPENED AND THE EXTRACTOR FAN RUNNING

FITTING TRIMS

Fit The Trim With Four Magnets Placed On The Vertical Side Flanges Of The Firebox (One At The Top And One At The Bottom)

Offer The Trim Up And Push Into Position

Place Fret Centrally In Front To Cover The Controls

INSTRUCT USER

DEMONSTRATE THE LIGHTING AND EXTINGUISHING PROCEDURES TO THE USER AND REMOVAL AND REFITTING OF THE TRIM FOR CLEANING.

THE APPLIANCE SHOULD BE OPERATED WITH THE GAS CONTROL NOT TURNED ON MORE THAN LOW FOR THE FIRST FIVE HOURS OF USE TO ALLOW THE FIBRE FUEL TO CURE SLOWLY.

THE CURING EFFECT OF HEATING THE FUEL AND OTHER CERAMICS COMPONENTS WILL CAUSE AN INITIAL ODOR.

THE APPLIANCE SHOULD BE SERVICED ANNUALLY BY A COMPETENT PERSON IN ACCORDANCE WITH THESE INSTRUCTIONS AND THE APPLIANCE CHECKED FOR SPILLAGE IN ACCORDANCE WITH THE METHOD DETAILED IN THESE INSTRUCTIONS

HAND THESE INSTRUCTIONS TO THE USER.

SERVICING NOTES

GENERAL NOTES.

SERVICING SHOULD BE CARRIED OUT ANNUALLY BY A COMPETENT PERSON SUCH AS A REGISTERED PERSON IN ACCORDANCE WITH THE RELEVANT REGULATIONS, TO ENSURE THE SAFE AND CORRECT OPERATION OF THE APPLIANCE

BEFORE COMMENING ANY SERVICE OR REPLACEMENT OF PARTS TURN OFF GAS SUPPLY TO FIRE

AFTER SERVICING CHECK FOR GAS SOUNDNESS

AT LEAST ONCE A YEAR CHECK FOR DEBRIS

IF SOOT HAS ACCUMULATED CHECK TO ESTABLISH CAUSE AND RECTIFY IF NECESSARY CLEAN FLUE OR CHIMNEY ACCORDINGLY

EXAMINE THE FUEL FOR SIGNS OF CRACKING AND REPLACE IF NECESSARY. SEE FUEL LAYOUT PROCEDURE BEFORE ATTEMPTING TO REPLACE FUEL WHICH SHOULD ONLY BE REPLACED AS A COMPLETE SET WITH NO EXTRA FUEL ADDED.

1 REMOVAL OF FUEL PIECES

REMOVE LOOSE FUEL PIECES
REMOVE FRONT FIBRE BASE
REMOVE MAIN FIBRE BASE

2 REPLACEMENT OF GAS CONTROL

REMOVE FUEL SET AS 1
DISCONNECT FIRE AT INLET ELBOW
REMOVE FIRETRAY BY UNSCREWING TWO SCREWS AT FRONT BOTTOM SECTION OF FIRE TRAY
REMOVE CONTRO KNOB,DISCONNECT GAS CONNECTIONS TO VALVE INCLUDING PILOT CONNECTION AND THERMOCOUPLE CONNECTION
REMOVE LOCKNUT HOLDING GAS CONTROL TO FRONT BOTTOM SECTION .
RE ASSEMBLE IN REVERSE ORDER
TURN ON GAS SUPPLY.CHECK FOR SOUNDNESS AND RE COMMISION APLIANCE

3 REPLACEMENT OF INJECTOR

REMOVE FUEL PIECES SEE 1
REPEAT 2 REMOVE GAS CONTROL
DISCONNECT GAS CONNECTION TO INJECTOR
UNSCREW INJECTOR "B" WHILST AT THE SAME TIME HOLDING LOCKNUT WITH A SPANNER AND CLEAN OR REPLACE.
SEE DIAGRAM BELOW.

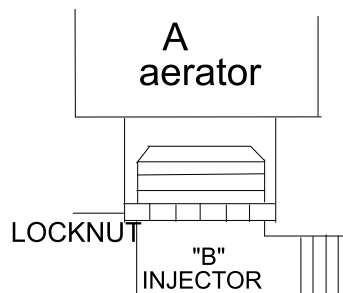

RE ASSEMBLE IN REVERSE ORDER
TURN ON GAS SUPPLY. CHECK FOR SOUNDNESS AND RECOMMISION THE FIRE.

REPLACEMENT OXY PILOT ASSEMBLY

DISCONNECT FIRE AT INLET ELBOW
REMOVE FIRETRAY
DISCONNECT THERMOCOUPLE AT GAS VALVE
DISCONNECT GAS CONNECTION FROM PILOT ASSEMBLY
REMOVE IGNITOR LEAD FROM PILOT ASSEMBLY
UNDO SCREWS SECURING OXY PILOT TO FIRETRAY
RE-ASSEMBLE IN REVERSE ORDER
TURN ON GAS SUPPLY, CHECK FOR SOUNDNESS AND RE-COMMISION APPLIANCE

CLEANING

BEFORE CLEANING ANY PART OF THE FIRE ,ENSURE THAT THE GAS IS TURNED OFF AND FIRE IS COOL.

BLACK PAINT.

USE ONLY CLEAN DAMP CLOTH ,DO NOT USE ANY CLEANING AGENTS

BRASS TRIM

USE BRASSO ENSURING YOU REMOVE THE BRASS TRIM FROM THE APPLIANCE BEFORE CLEANING

IMPORTANT

THE PAINT AND BRASS FINISH ARE DURABLE BUT WILL BE DAMAGED IF PLASTER,CEMENT,OR WALLPAPER PASTE COMES IN CONTACT WITH IT

COALS AND CERAMICS

IF FOR ANY REASON IT IS NECCESARY TO REMOVE CERAMIC PARTS,THEN BEFORE REPLACEMENT THE BURNER SHOULD BE CHECKED THAT NO PARTICLES HAVE DEPOSITED ON THE BURNER AND IF NECCESARY VACUUM THEM CAREFULLY ,THEN REFER TO INSTRUCTIONS FOR REPLACING CERAMICS.

CERAMICS SHOULD BE CLEANED BY SHAKING ANY DEBRIS
NO BRUSHING OR VACUUMING SHOULD BE PERFORMED .

INSTALLER SPARE PARTS

FUEL BED	GEM001	MAIN MATRIX	GEM002
FRONT FIBRE	GEM003	INSTUCTIONS	GEM 004
BRASS TRIM	GEM 005	ODS COMPLETE	GEM006
GAS VALVE	GEM 007	REMOTE GAS VALVE	GEM 008
REMOTE ODS	GEM 009		

CRYSTAL FIRES

1 BECHERS DRIVE
AINTREE RACECOURSE
BUSINESS PARK
AINTREE
LIVERPOOL
L9 5AY

GEM

DECORATIVE FUEL EFFECT GAS FIRE

THIS APPLIANCE IS CATEGORY I_{2H} FOR USE
WITH NATURAL GAS AT A SUPPLY
PRESSURE OF 20 mbar OR CATEGORY I_{3P}
FOR USE WITH PROPANE AT A SUPPLY
PRESSURE OF 37mbar
G.B. AND I.E.

USERS INSTUCTIONS

USERS INSTRUCTIONS FOR GEM GAS APPLIANCE

YOUR GEM GAS APPLIANCE IS A DECORATIVE LIVE FUEL EFFECT GAS FIRE ,DUE TO ITS NEWNESS THE FIRE MAY GIVE OFF SLIGHT SMELL FOR A SHORT PERIOD AFTER INSTALLATION .THIS IS QUITE NORMAL AND WILL DISAPPEAR AFTER A FEW HOURS OF OPERATION.

THE APPLIANCE TO WHICH THESE INSTRUCTIONS APPLY MUST BE INSTALLED BY A COMPETENT PERSON(EG. A REGISTERED INSTALLER IN ACCORDANCE WITH THE CURRENT EDITION OF THE GAS SAFETY INSTALLATIONS AND USE REGULATIONS OR THE RULES IN FORCE)APPROVED BY THE HEALTH AND SAFETY EXECUTIVE AND MUST BE IN ACCORDANCE WITH THE INSTALLATION AND SERVICING INSTUCTIONS SUPPLIED. SERVICING SHOULD BE CARRIED OUT REGULARLY BY A COMPETENT PERSON (EG A REGISTERED INSTALLER)IN ACCORDANCE WITH THE CURRENT EDITION OF THE GAS SAFETY (INSTALLATION AND USE) REGULATIONS OR THE RULES IN FORCE.TO ENSURE THE CORRECT AND SAFE OPERATION OF THE APPLIANCE .DEBRIS SHOULD ALSO BE REMOVED FROM BEHIND THE APPLIANCE AT REGULAR INTERVALS.

BEFORE INSTALLATION OF THE APPLIANCE THE CHIMNEY MUST BE SWEEPED AND THEN INSPECTED REGURLARLY TO ENSURE THAT IT REMAINS FREE OF OBSTRUCTION.

A FIRE GUARD COMPLYING TO BS8423 ,MUST BE FITTED IF THE ROOM WILL BE OCCUPIED BY YOUNG CHILDREN THE ELDERLY ,OR INFIRM PEOPLE. ON NO ACCOUNT MUST ANY RUBBISH BE THROWN ON TO THE FIRE OR THE LAYOUT OF THE FIREBED DISTURBED.

OPERATING INSTRUCTIONS.

THE APPLIANCE DATA BADGE IS POSITIONED ON THE FRONT BOTTOM SECTION OF THE APPLIANCE AND CARRIES THE CONTROL KNOB POSITIONS.THE FULL LIGHTING PROCEDURE IS AS FOLLOWS.

- 1.PUSH CONTROL KNOB IN AS FAR AS POSSIBLE ON GAS CONTROL
 - 2.TURN KNOB ANTICLOCKWISE TO IGNITION POSITION STILL KEEPING KNOB IN AS FAR AS POSSIBLE.
 - 3.THE IGNITION BUTTON WILL IGNITE THE PILOT WITH THIS OPERATION KEEP THE KNOB PRESSED IN FOR 15 SECONDS.IF THE PILOT FAILS TO LIGHT TURN THE CONTROL KNOB CLOCKWISE TO THE OFF POSITION, WAIT 3 MINUTES AND REPEAT THE PROCEDURE
 - 4.WHEN THE PILOT FLAME IS ALIGHT THE CONTROL KNOB SHOULD BE ALLOWED TO SPRING OUT SLIGHTLY.TURN THE KNOB FULLY ANTICLOCKWISE TO THE HIGH POSITION.THE PILOT FLAME WILL THEN IGNITE THE MAIN BURNER.THE PILOT FLAME CAN BE VIEWED TO THE RIGHT OF THE FIRE JUST BEHIND THE FRONT LOG SET
 - 5.THE APPLIANCE CAN BE ADJUSTED BETWEEN HIGH AND LOW BY MOVING THE CONTROL KNOB TO SUIT,THE KNOB WILL NEED TO BE DEPRESSED SLIGHTLY TO MOVE FROM LOW HIGH AND IGNITION.
 - 6.TO TURN THE FIRE OFF,DEPRESS THE KNOB SLIGHTLY AND TURN IT TO PILOT POSITION.
 - 7.TO COMPLETELY EXTINGUISH THE FIRE DEPRESS THE KNOB SLIGHTLY AND TURN TO OFF POSITION.
 - 8.SHOULD THE SPARK IGNITION FAIL TO OPERATE.TURN THE CONTROL KNOB TO THE OFF POSITION AND WAIT 3 MINUTES.TURN THE KNOB TO THE IGNITION POSITION AND THEN LIGHT THE PILOT WITH A TAPER.”LIGHTING THE PILOT WITH A TAPER IS AN EMERGENCY MEASURE ONLY AND THE APPLIANCE SHOULD BE SERVICED AS SOON AS POSSIBLE”.AND THEN PROCEED AS STATED IN PARAGRAPHS 2/7.
- IMPORTANT .THIS APPLIANCE IS FITTED WITH AN OXYGEN DEPLETION SENSOR INCORPORATED INTO THE PILOT BODY.SHOULD THE FIRE REEATEDLY EXTINGUISH ITSELF THEN SPECIALIST ADVISE SHOULD BE SOUGHT,AS THIS MAY INDICATE SPILLAGE INTO THE ROOM OF COMBUSTION PRODUCTS.

MERTIK MAXITROL REMOTE CONTROL SYSTEM

THESE INSTRUCTIONS ARE FOR THE USE ON CRYSTAL FIRES REMOTE CONTROL RANGE OF GAS FIRES

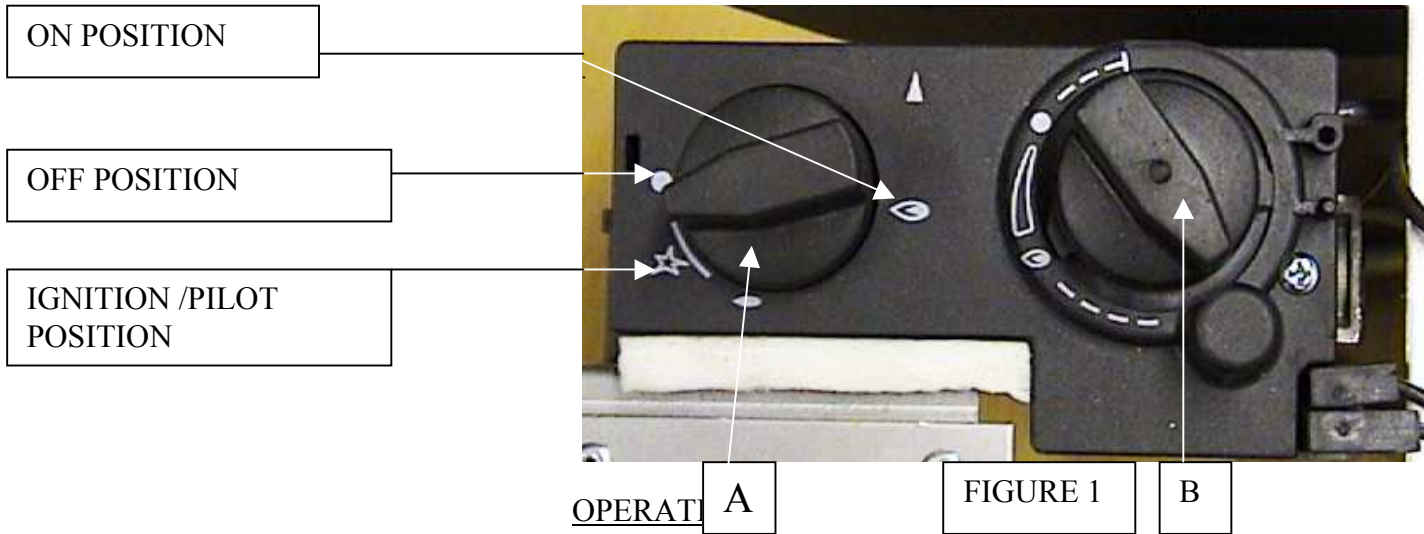

LIGHTING PROCEDURE

1. TURN KNOB A (FIGURE 1) SLIGHTLY LEFT TOWARDS THE IGNITION POSITION(SHOWN IN FIG 1 ABOVE) UNTIL REACHING STOP,PRESS DOWN AND HOLD FOR FIVE SECONDS (ONLY PILOT GAS FLOWS)
2. CONTINUE PRESSING DOWN KNOB A WHILE TURNING FURTHER LEFT TO ACTIVATE PIEZO,CONTINUE TO HOLD DOWN FOR 10 SECONDS AFTER PILOY HAS BEEN LIT,IF PILOT DOES NOT LIGHT,STEPS 1 AND 2 CAN BE REPEATED IMMEDIATELY.
3. UPON LIGHTING,RELEASE KNOB A AND TURN FURTHER LEFT TO ON POSITION (SHOWN IN FIGURE 1 ABOVE)PILOT GAS FLOWS AND MAIN BURNER FLOWS IN ACCORDANCE TO THE TEMPERATURE SETTING(KNOB B AS SHOWN IN FIG 1 ABOVE)

ADJUSTING THE FLAME SETTINGS

TO TURN THE FIRE ON AND/OR TO ADJUST THE FLAME STTING, PRESS THE ON BUTTONS ON THE REMOTE HANDSET.CONTINUE PRESSING UNTIL DESIRED FLAME SETTING IS OBTAINED.PRESS AND HOLD THE OFF BUTTON TO REVERSE THE SETTING.THE RECEIVER IS EQUIPPED WITH A BUILT IN DELAY, RECOGNIZABLE BY THE FLICKERING LIGHT,TO FACILITATE FINE ADJUSTMENT OF THE FLAME THE MOTORIZED VALVE IS EQUIPPED WITH A SLIP CLUTCH ,ALLOWING MANUAL ADJUSTMENT OF MAIN GAS BY TURNING KNOB B



ON BUTTONS
TO PRESS THE ON BUTTON
YOU MUST PRESS THE 2
BUTTONS TOGETHER

ISSUE 1

SHUT OFF PROCEDURE

1.TURN KNOB A RIGHT UNTIL REACHING STOP. IN THIS POSITION ONLY PILOT GAS FLOWS

2.TO SHUT OFF VALVE COMPLETELY,PRESS DOWN SLIGHTLY AND CONTINUE TURNING RIGHT FROM PILOT POSITION TO THE OFF POSITION.THE SAFETY INTERLOCK PREVENTS RE-IGNITION OF THE PILOT FLAME UNTIL THERMOCOUPLE HAS COOLED DOWN SUFFICIENTLY(ELAPSED TIME WILL VARY BASED ON THERMOCOUPLE TYPE)

3.SWITCHING OFF THE REMOTE IS NOT NECESSARY.



THE SENSOR AND BATTERY HOLDER A INSERTED BENEATH THE RIGHT SIDE OF THE FIRE.TO REPLACE BATTERIES ALLOW FIRE TO COOL FOR AT LEAST 30 MINUTES THEN PULL OUT BATTERY HOLDER, THE COVER CAN SLIDE OFF AS ABOVE AND THE BATTERIES CAN BE REPLACED.(USE ONLY LIKE FOR LIKE ALKALINE AA BATTERIES)

REPLACEMENT PARTS

BATTERY HOLDER AND SENSOR

GAS VALVE

REMOTE HANDSET

CRYSMERTIKHOLDER

CRYSMERTIKVALVE

CRYSMERTIKHANDSET

CLEANING

BEFORE CLEANING ANY PART OF THE FIRE ,ENSURE THAT THE GAS IS TURNED OFF AND FIRE IS COOL.

BLACK PAINT.

USE ONLY CLEAN DAMP CLOTH ,DO NOT USE ANY CLEANING AGENTS

BRASS TRIM

USE BRASSO,ENSURING YOU REMOVE THE BRASS TRIM FROM THE APPLIANCE BEFORE CLEANING

IMPORTANT

THE PAINT AND BRASS FINISH ARE DURABLE BUT WILL BE DAMAGED IF PLASTER,CEMENT,OR WALLPAPER PASTE COMES IN CONTACT WITH IT

COALS AND CERAMICS

IF FOR ANY REASON IT IS NECCESARY TO REMOVE CERAMIC PARTS,THEN BEFORE REPLACEMENT THE BURNER SHOULD BE CHECKED THAT NO PARTICLES HAVE DEPOSITED ON THE BURNER AND IF NECCESARY VACUUM THEM CAREFULLY,THEN REFER TO INSTRUCTIONS FOR REPLACING CERAMICS.
CERAMICS SHOULD BE CLEANED WITH A SOFT BRUSH



THE TAPER SHOULD BE POSITIONED TO THE PILOT TO THE FAR RIGHT OF CURVED FRONT PIECE AND LEVEL WITH PIECE 1 SHOWN LEVEL WITH THE LINE BELOW



THE GEM CAN BE LIT WITH A TAPER SHOULD THE SPARK IGNITION FAIL TURN THE KNOB TO THE OFF POSITION AND WAIT 3 MINUTES TURN THE KNOB TO THE IGNITION POSITION AND THEN LIGHT THE PILOT WITH A TAPER
THIS IS ONLY AN EMERGENCY MEASURE AND THE APPLIANCE SHOULD BE SERVICED AS SOON AS POSSIBLE,THEN PROCEED AS STATED EARLIER FOR OPERATION

COAL BED LAYOUT

PERIODICALLY SMALL DEPOSITS OF SOOT MAY GATHER ON THE FUEL BED AND BURNER, THIS MUST BE REMOVED BY REMOVING FUEL AND BRUSHING ANY DEPOSITS WITH A SOFT BRUSH AND VACUUMING THE BURNER, THEN REPLACE FUEL USING THE FOLLOWING PROCEDURE.



Main ceramic matrix sits on back base central



Front piece sits in to well of burner and flat onto the curved front of fire tray
Flat and stable



Piece marked underneath 1 sits snugly above front piece
central and touching left side and right



The rear piece can be fitted to the top
Sitting central and behind the coal pieces on the
side matrix.
Sitting flat



Piece marked underneath 2 sits flat centrally above
piece 1 onto the flat ledge on the main matrix
Piece 2 should not be touching piece 1 and there
should be a gap of approx 5mm



Final piece marked underneath 3 sits on top of
piece 2 and to the rear pieces
This piece should not actually touch the rear
piece and there should be a gap of approx 5 mm

THE EFFECT CAN ALSO COME AS PEBBLES THE LAYOUT IS EXACTLY THE SAME AS ARE
THE PIECES HOWEVER THE TOP EFFECT LOOKS LIKE PEBBLES RATHER THAN COAL.

FUEL BED GEM001
FRONT FIBRE GEM 003
BRASS TRIM GEM 005

CUSTOMER SPARE PARTS
MAIN MATRIX GEM002
INSTUCTIONS GEM 004

REAR MATRIX SITS BEHIND 2 LUGS AND FLAT
ON BASE SEE BELOW



FRONT FIBRE SITS IN WELL OF BURNER AS ABOVE



FRONT 4 LOOSE COALS SIT AS ABOVE



NEXT SET OF 3 FIT AS SHOWN ABOVE WITH
THE LEFT AND RIGHT HAVING THE POINT OF THE
COAL POINTING OUTWARDS

GEM LOOSE COAL SET UP



NEXT 2 SIT AS ABOVE AGAIN WITH
THE POINTS OF THE COALS LOOKING OUTWARDS



FINAL 3 SIT CENTRALLY ON TOP
AS ABOVE

