

## CASSETTE 400/600 CAS400, CAS600

08/35608/0 Issue 3

Fig. 1

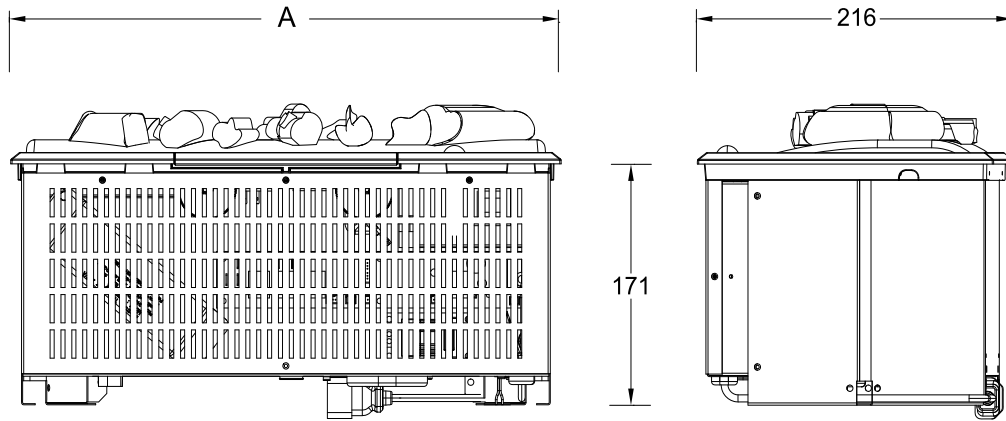

	'A' mm
CAS400	405
CAS600	564

Fig. 2

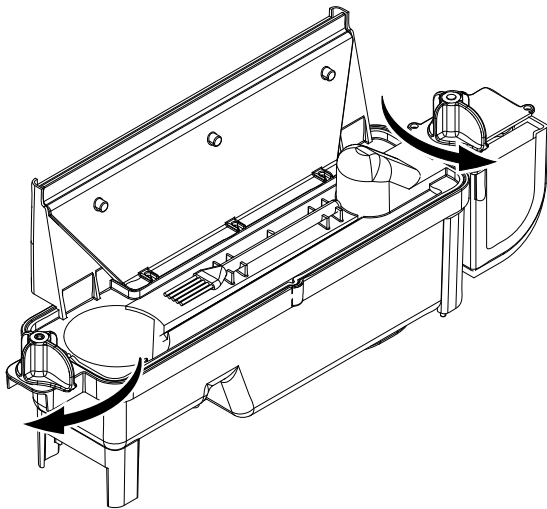

Fig. 3

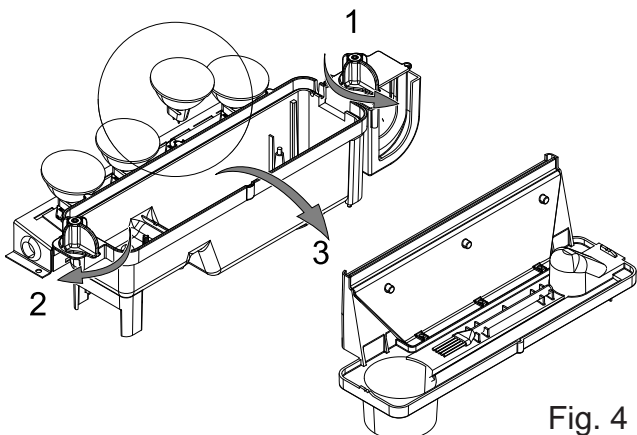
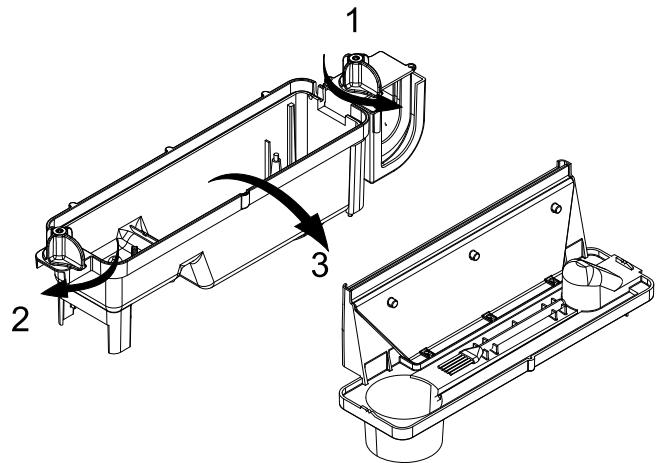

Fig. 4

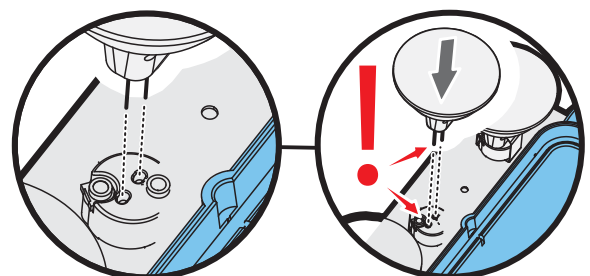

Fig. 4a

Fig. 5

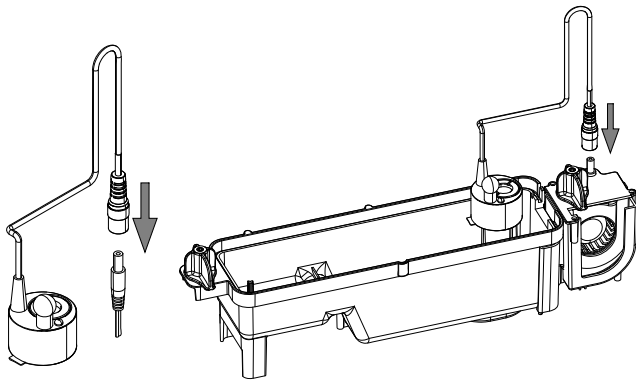

Fig. 5a

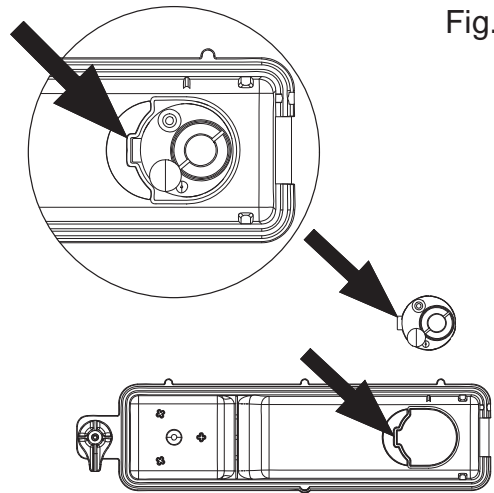

Fig. 5b

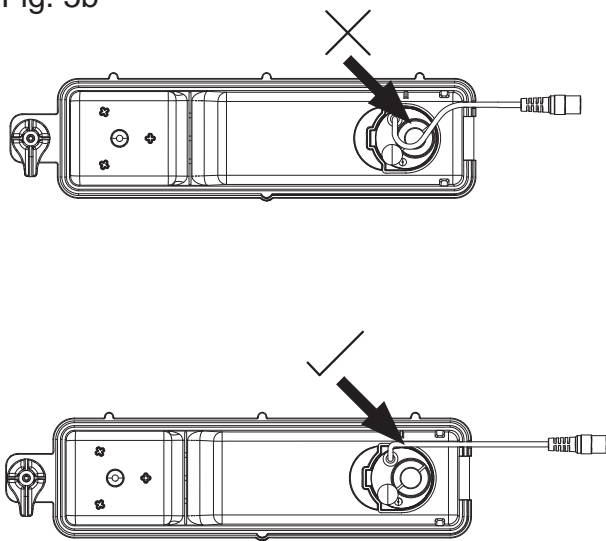

Fig. 6

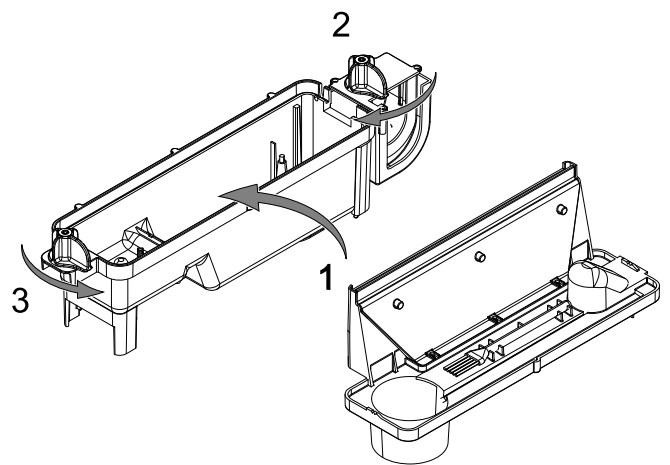

Fig. 7

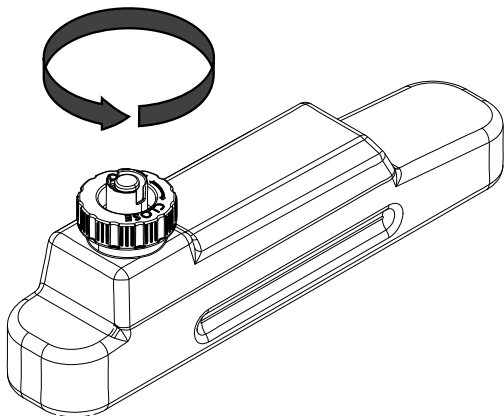

Fig. 8

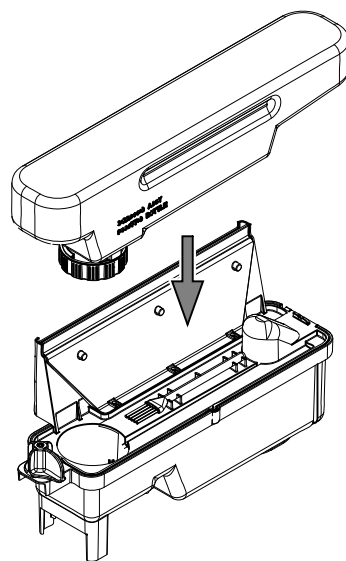

Fig. 9

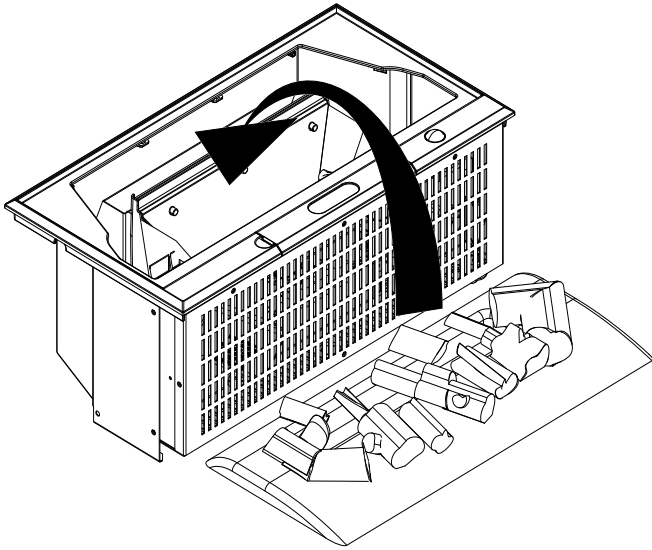

Fig. 10

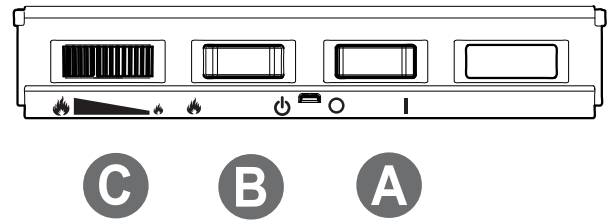

Fig. 11

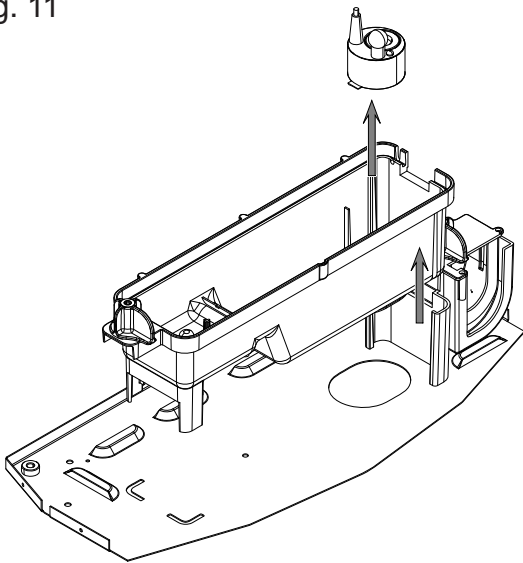

Fig. 12

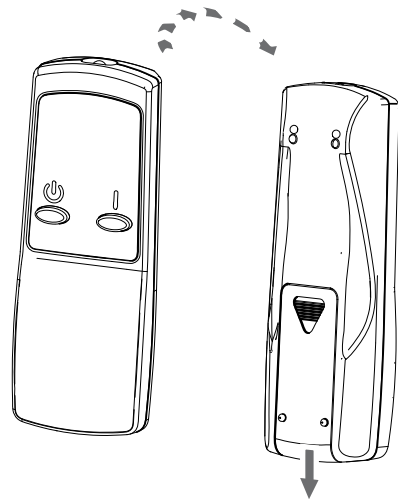

Fig. 13

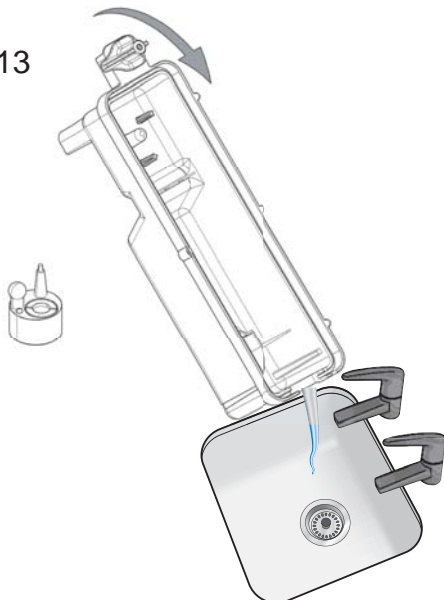

Fig. 14

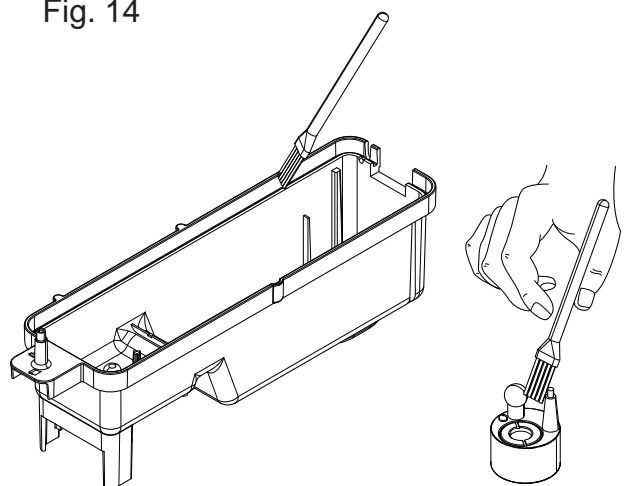

Fig. 15

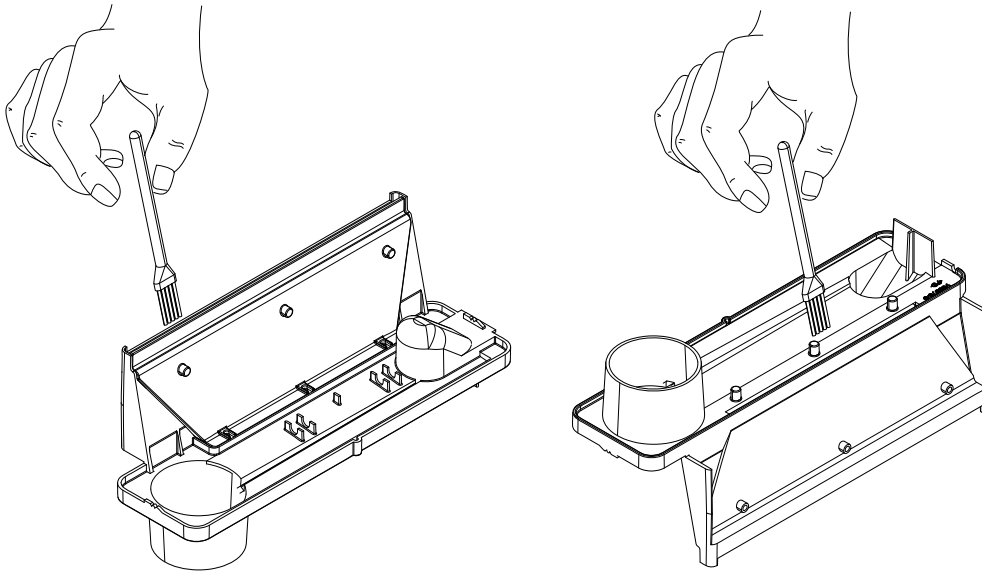

Fig. 16

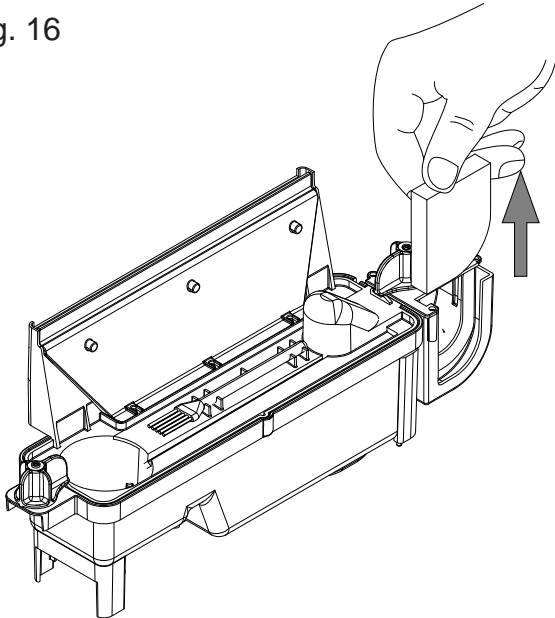

Fig. 17

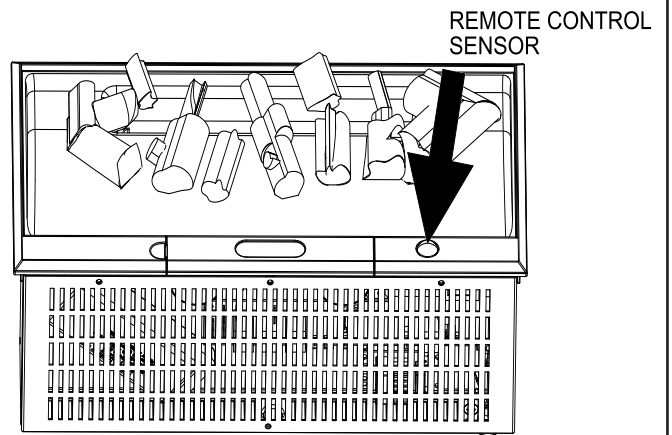

Fig. 18

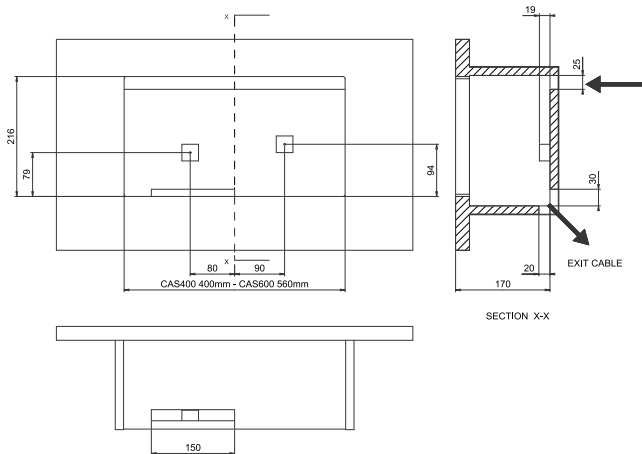
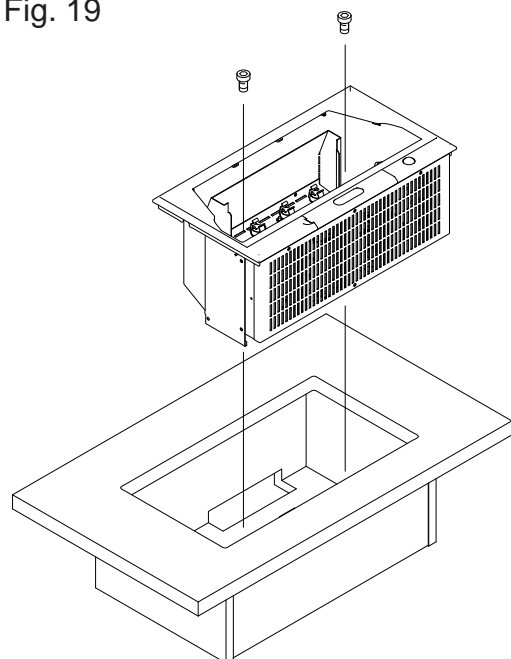

Fig. 19



# Dimplex OPTIMYST CAS400, CAS600

## Introduction

Thank you for choosing this Dimplex electric fire. Please read this information guide carefully to be able to safely install, use and maintain your product.

## Important Safety Advice

When using electrical appliances, basic precautions should always be followed to reduce the risk of fire, electrical shock and injury to persons, including the following:

### 1. WARNING

Do not place material or garments on, or obstruct the air circulation around the appliance.

This appliance carries a DO NOT COVER warning

### 2. DAMAGE

If the appliance is damaged, check with the supplier before installation and operation.

If the supply cord is damaged it must be replaced by the manufacturer or service agent or a similarly qualified person in order to avoid a hazard.

### 3. LOCATION

Do not use outdoors.

Do not use in the immediate surroundings of a bath, shower or swimming pool.

Do not locate the fire immediately below a fixed socket outlet or connection box.

Ensure that furniture, curtains or other combustible material are positioned no closer than 1 metre from the appliance.

### 4. PLUG POSITIONING

The appliance must be positioned so that the plug is accessible.

Keep the supply cord away from the front of the appliance.

### 5. UNPLUGGING

In the event of a fault unplug the device.

Unplug the device when not required for long periods.

### 6. OWNER/USER

This appliance can be used by children aged from 8 years and above and persons with reduced physical, sensory or mental capabilities or lack of experience and knowledge if they have been given supervision or instruction concerning use of the appliance in a safe way and understand the hazards involved. Children shall not play with the appliance. Cleaning and user maintenance shall not be made by Children without supervision.

Children of less than 3 years should be kept away unless continuously supervised. Children aged from 3 years and less than 8 years shall only switch on/off the appliance provided that it has been placed or installed in its intended normal operating position and they have been given supervision or instruction concerning use of the appliance in a safe way and understanding the hazards involved. Children aged from 3 years and less than 8 years shall not plug in, regulate and clean the appliance or perform user maintenance.

### 7. ELECTRICITY

**WARNING – THIS APPLIANCE MUST BE EARTHED.**

This appliance must be used on an AC ~ supply only and the voltage marked on the appliance must correspond to the supply voltage. Before switching on, please read the safety advice and operating instructions.

**CAUTION** — Some parts of this product can become very hot and cause burns. Particular attention has to be given where children and vulnerable people are present.

**WARNING** - In order to avoid overheating, do not cover the appliance

## General Information

Only use filtered water in this appliance.

To reduce heat loss and to prevent any chimney up draft affecting the operation of your inset fire we recommend they the chimney flue is sealed off.

Always ensure that the appliance is sitting on a level surface.

Please note: Used in an environment where background noise is very low, it may be possible to hear a sound which is related to the operation of the flame effect. This is normal and should not be a cause for concern.

If this product experiences a power surge for whatever reason the product may cut-out. This is a normal safety feature and the product will resume operation after 30 seconds.

Once installed, never move this appliance or lay on its back, without draining the water from sump and water tank.

If you intend not using the appliance for longer than 2 weeks, drain the water from sump and water tank and dry the sump.

The water tank, sump, sump lid, tank cap and air filters must be cleaned once every two weeks, particularly in hard water areas.

The appliance should never be operated if the lamps are not working.

The lamps should be regularly inspected as described under 'Maintenance' and 'Changing lamps'.

## Installation Instructions

This appliance has been designed to be housed in separately designed structures – e.g. furniture, fireplace surrounds etc.

To incorporate this appliance into another structure, it should be securely fitted, following these guidelines:

1. Construct an opening for the appliance (Fig 18)
2. Ensure that there is sufficient room to thread through the mains cable
3. A cavity of at least 100cm<sup>2</sup> is required to ensure air can circulate into the appliance. This pathway for air must not be obstructed.
4. Lower the appliance into the opening (Fig 19)
5. Remove the water sump, to enable access to the screw holes.
6. Screw the appliance into the structure by using suitable screws, not supplied.

### BEFORE YOU START

1. Ensure that all packing items are removed (read any warning labels carefully) and retain all packing for possible future use e.g. in the event of moving house or returning the appliance to your supplier.
2. Before connecting to the mains supply, check that the supply voltage is the same as that stated on the appliance.

### INSTALLATION

Place the appliance against a wall.

#### Connecting the Transducer Unit + Lamps

1. Release the two red tabs by turning them by 90 degrees (see Fig 2)
2. Lift out the Sump Nozzle (Fig 3)
3. Insert lamps into lamp holders (Fig 4), carefully locating the pins into the holes (Fig 4a)
4. Push lamps firmly into place
5. Place the Transducer Unit into the sump and join the cable to the connector on the sump (Fig 5)
6. To ensure that the Transducer Unit is correctly placed in the sump, the tab on the Transducer Unit should be lined up with the moulded recess in the sump (Fig 5a).
7. Ensure that the cable is not placed above the disc on the Transducer Unit (Fig 5b). To prevent the cable becoming pinched between the nozzle and the sump, place the cable in the slot in the wall of the sump.
8. Replace the Sump Nozzle and secure it by turning the two red tabs by 90 degrees (Fig 6)

#### Filling the Water Tank

9. Place Water Tank in sink and remove cap (turn anti-clockwise to open) (Fig 7)
10. Fill Water Tank with **filtered tap water only**. This is necessary to prolong the life of the flame and smoke effect producing unit. The water should be filtered through a conventional domestic water filter unit and the filter should be replaced regularly. Distilled water must **not** be used.
11. Screw the cap back on – **do not overtighten**.
12. Place the Water Tank in the Sump, with the tank cap facing down and the flat side of the tank facing outward (Fig 8)

#### Assembling the fire

13. Place the Fuelbed on top of the Water Tank and Mist Nozzle (Fig 9)

Connect the power cable to the appropriate power connector at the back of the appliance and Plug the power cable into a 13amp/240volt outlet. The appliance is now ready for use.

## Operating the Fire

This section describes how to activate your fire using either the manual controls or remote control.

### MANUAL CONTROLS

The manual controls are located beneath the hinged flap.  
(See Fig.10 for Manual Control lay out)

Switch 'A':- Controls the electricity supply to the Fire.

Note: This switch must be in the 'ON' ( I ) position for the Fire to operate.

Switch 'B':- Press  once to turn on the flame effect. This will be indicated by an audible beep. Although the main lights operate immediately it will take a further 30 seconds before the flame effect starts.

Press  to put fire in to standby mode. This will be indicated by one beep.

Control Knob 'C':- Controls the intensity of the flame effect.

Turning the control knob to the left increases the flame effect, turning the control knob to the right will decrease the flame effect.





## GETTING THE DESIRED FLAME EFFECT

1. The flame control knob 'C' (Fig.10) may be turned up or down to give a more realistic effect.
2. Generally the flames appear more realistic when the flame control is turned down.
3. Give the flame generator time to react to changes you may make.
4. The appliance will use less water if the flame effect is set to a lower level (control knob 'C').
5. Do not tilt or move the appliance while there is water in the tank or sump.
6. Make sure that the appliance is on a level floor.

## REMOTE CONTROL OPERATION

On the control panel, Switch A (see Fig.10) must be in the 'ON' ( I ) position in order for the remote control to operate. There are 3 buttons on the remote control. (See Fig.12) To operate correctly the remote must be pointed towards the front of the grate. (See Fig 17). The remote control functions are as follows:

 Press once to turn on Flame effect.  
This will be indicated by one beep.

 Standby  
This will be indicated by one beep.

## Maintenance

### GENERAL TIPS

Only use filtered tap water in this appliance.

Always ensure that the appliance is sitting on a level surface.

If you intend not using the appliance for longer than 2 weeks, remove and empty the sump and water tank.

Once installed, never move this appliance or lay on its back, without draining the water from sump and water tank.

The appliance should never be operated if the lamps are not working.

The lamps should be regularly inspected as described under 'Changing lamps'.

### FILLING THE WATER TANK

When the water tank is empty, the flame and smoke effect shuts off and you will hear 2 audible beeps, follow these steps.

1. Press Switch 'A' to (0) (See Fig.10)
2. Gently lift out the fuelbed and carefully set aside.
3. Remove the water tank by lifting upwards and outwards.
4. Place the water tank in sink and remove cap, Anti-clockwise to open. (Fig 7)
5. Fill tank with **filtered tap water only**. This is necessary to prolong the life of the flame and smoke producing unit. The water should be filtered through a conventional domestic water filter unit and the filter should be replaced regularly.
6. Screw the cap back on, do not over tighten.
7. Return the tank to the sump, with the tank cap facing down and the flat side of the tank facing outward. (Fig 8)
8. Gently place the fuelbed back into position. (Fig 9)
9. Press Switch 'A' to 'ON' (I) position (See Fig.10)

### CHANGING LAMPS

If the flame and smoke effect appears grey or colourless it may be that one or more lamps have failed.

You can check for lamp failure as follows.

1. Leaving the flame effect on, lift out the fuelbed and water tank.
2. It should be possible to view the lamps with the nozzle in place and observe which one needs to be changed.
3. Put Switch 'A' in the 'OFF' (0) position, and unplug the fire from the mains.
4. Leave the appliance for 20 minutes to allow the lamps to cool down before removing them.
5. Remove the sump as described in the Cleaning Section.

6. Remove the defective lamp, by gently lifting vertically and disengaging the pins from the lamp holder, (See Fig.4 and 4a).

Replace with a Dimplex OPTIMYST, 12V, 45W, Gu5.3 base, 8° beam angle, coloured lamp. (Purchased from our website <http://spares.dimplex.co.uk>)

7. Carefully insert the two pins of the new lamp into the two holes in the lamp holder. Push firmly in place. (See Fig.4 and 4a).

8. Replace the sump, nozzle, water tank and fuelbed.

### CLEANING

**Warning** – Always press Switch 'A' to the 'OFF' (0) position (See Fig.10) and disconnect from the power supply before cleaning the fire.



We recommend cleaning the following components once every 2 weeks, particularly in hard water areas:-

Water Tank, Sump, Nozzle, Tank cap and seal, Air filter.

For general cleaning use a soft clean duster – never use abrasive cleaners.

To remove any accumulation of dust or fluff, the soft brush attachment of a vacuum cleaner should occasionally be used.

### **Water tank**

1. Remove water tank, as described earlier, put into sink and empty water.
2. Using the supplied brush gently rub the inside surfaces of the cap paying particular attention to the rubber ring in the outer groove and the centre rubber seal.
3. Put a small quantity of washing up liquid into the tank, refit the cap and shake well, rinse out until all traces of washing up liquid are gone.
4. Refill with filtered tap water only, replace the cap, do not overtighten.

### **Sump**

1. Press Switch 'A' to the 'OFF' (0) position
2. Gently lift out the fuelbed and place carefully on the ground.
3. Remove the water tank by lifting upwards.
4. Disconnect the electrical connector, located on the right side of the sump. (See Fig.5) .
5. Release the right sump locking tabs by turning 90°. This allows the sump to be lifted completely from its location.
6. Gently lift up the sump, taking care to keep level so as not to spill any water. Sit the assembly in the sink.
7. Release the left sump locking tabs by turning 90°, then lift off the Nozzle. (See Fig.3)
8. Lift out the transducer and carefully tilt, as shown, so that the liquid drains out of the sump. (See Fig.13)
9. Put a small amount of washing up liquid into the sump, and using the supplied brush, gently clean all surfaces in the sump and gently clean the transducer including the metal discs located in the top grooved surface. (See Fig.14)
10. When cleaned, thoroughly rinse the sump with clean water to remove all traces of washing up liquid.
11. Clean the Nozzle with the brush and flush out thoroughly with water. (See Fig.15)
12. Reverse the above steps to reassemble.

### **Air filter**

1. Gently lift out the fuelbed and place carefully on the ground.
2. Gently slide the air filter upwards out of its plastic holder. (See Fig.16)
3. Gently rinse with water in the sink and dry with fabric towel before returning.
4. Replace the filter making sure that the coarse black filter is facing the front of the fire.
5. Replace the fuelbed.

## Additional Information

### AFTER SALES SERVICE

Your product is guaranteed for one year from the date of purchase. Within this period, we undertake to repair or exchange this product free of charge (excluding lamps & subject to availability) provided it has been installed and operated in accordance with these instructions. Your rights under this guarantee are additional to your statutory rights, which in turn are not affected by this guarantee.

Should you require after sales information or assistance with this product please go to [www.dimplex.co.uk](http://www.dimplex.co.uk) and select "Customer Support" or ring our help desk on 0845 600 5111 (UK) or 01 842 4833 (R. O. I.). Spare parts are also available on the web site. Please retain your receipt as proof of purchase.

### RECYCLING



For electrical products sold within the European Community - At the end of the electrical products useful life it not be disposed of with household waste. Please recycle where facilities exist. Check with your Local Authority or retailer for recycling advice in your country.

### PATENT / PATENT APPLICATION

Products within the Optimyst range are protected by one or more of the following patents and patent applications:

Great Britain GB 2402206, GB 2460259, GB 2460453 , GB 2418014, GB 2465738, GB 2449925, GB 2465537 , GB 2455277 , GB1020534.2, GB1020537.5, GB1110987.3

United States US 7967690, US 2010299980, US 2011062250, US 2008028648, US 13/167,042

Russia RU2008140317

European EP 2029941, EP 2201301, EP 2315976, EP 1787063, EP07723217.1 , EP11170434.2, EP 11170435.9

China CN 101883953, CN 200980128666.2, CN 101057105, CN 101438104

Australia AU 2009248743, AU 2007224634

Canada CA 2725214, CA 2579444, CA 2645939

International Patent Application WO 2006027272

South Africa ZA 200808702

Mexico MX 2008011712

Korea KR 20080113235

Japan JP 2009529649

Brazil BR P10708894-9

India IN 4122/KOLNP/2008

New Zealand NZ 571900

## Troubleshooting

Symptom	Cause	Corrective Action
The flame effect will not start.	<p>Mains plug is not plugged in.</p> <p>Low water level.</p> <p>Low voltage connector not connected properly. (See Fig.5)</p> <p>The Transducer Unit is not sitting correctly in the sump</p>	<p>Check plug is connected to wall socket correctly.</p> <p>Check that the water tank is full and there is water in the sump.</p> <p>Check that the connector is inserted correctly. (See Fig.5)</p> <p>Ensure the Transducer is sitting down into the moulded recess in the sump</p>
The flame effect is too low.	<p>Flame effect control knob is set too low. (See Fig.10)</p> <p>The Metal Disc in the transducer might be dirty (See Fig.14)</p> <p>The wire from the Transducer Unit is sitting over the metal disc</p>	<p>Increase level of flame by turning Control knob 'D' to the left slowly. (See Fig.10)</p> <p>Clean the Metal Disc with soft brush supplied. (See Fig.14) See 'Maintenance.' for a step by step procedure.</p> <p>Direct the wire to the back of the sump and make sure it sits into the side slot exiting the sump.</p>
Unpleasant smell when unit is used.	<p>Dirty or stale water.</p> <p>Using unfiltered tap water.</p>	<p>Clean the unit as described under maintenance.</p> <p>Use only filtered tap water.</p>
The flame effect has too much smoke.	<p>Flame effect setting is too high.</p>	<p>Turn the flame effect Control knob 'D' to the right, about ¼ a turn, at a time. Give the flame generator some time to adjust to the new setting. (See Fig.10)</p>
Main lamps are not working and there are no flames or smoke.	<p>There is no water in the water tank</p>	<p>Follow instructions under <b>Maintenance</b>, 'Filling the water tank'.</p> <p>Check the plug is connected to the wall socket correctly and that Switch 'A' Fig. 10 is in the 'ON' ( I ) position.</p>

---

OPTIMYST is a trade mark of GDC Group Ltd.

---

GDC Group Ltd.  
MILLBROOK HOUSE  
GRANGE DRIVE  
HEDGE END  
SOUTHAMPTON  
SO30 2DF

TEL: 0845 600 5111  
FAX: 01489 773050  
WEBSITE: [www.dimplex.co.uk](http://www.dimplex.co.uk)  
Republic of Ireland      Tel. 01 8424833

---

© GDC Group Ltd,  
All rights reserved. Material contained in this publication may not be reproduced in whole or in part, without prior permission in writing of Dimplex.  
A division of GDC Group Ltd.