

Dimplex®

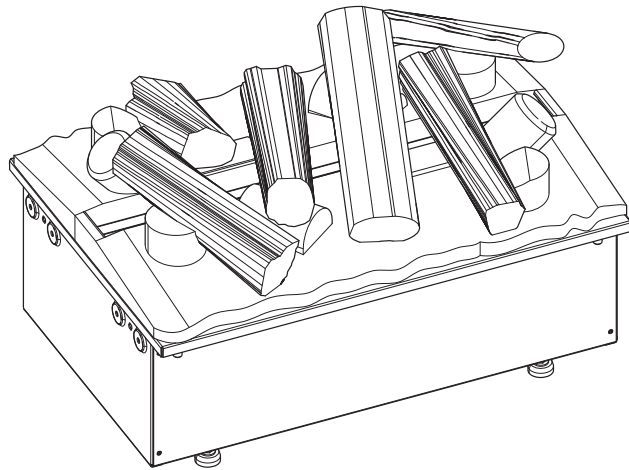

CAS500R

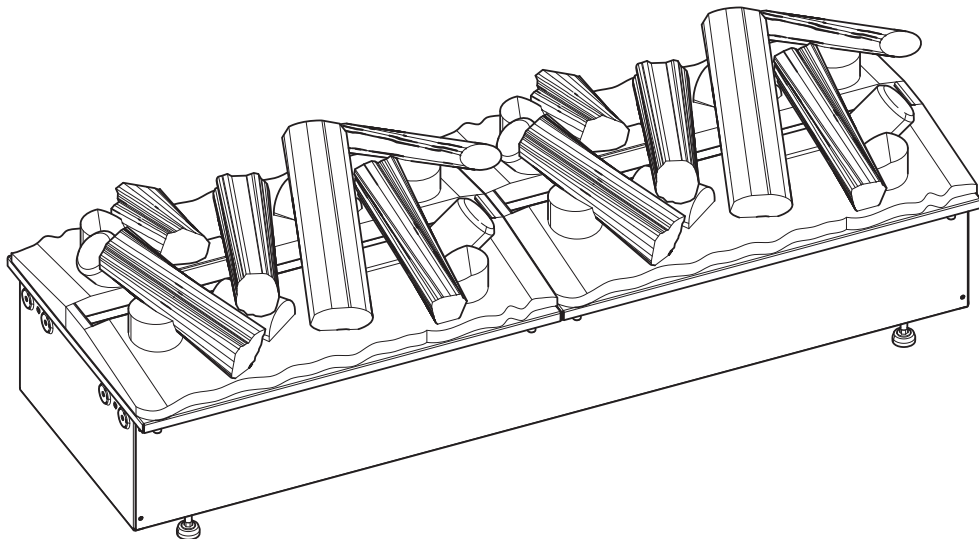

CAS1000R



08/53960/0 Issue 6
OCN 11958



This product complies with all the required Product Safety, Electromagnetic Compatibility and Environmental Standards. This product is fully compliant with the LVD, EMC, RoHS and Eco Design Directives.

Dimplex CAS500R, CAS1000R

Introduction

Please read this information guide carefully to be able to safely install, use and maintain your product.

Important Safety Advice

When using electrical appliances, basic precautions should always be followed to reduce the risk of fire, electrical shock and injury to persons, including the following:

If the appliance is damaged, check with the supplier before installation and operation.

Do not use outdoors.

Do not use in the immediate surroundings of a bath, shower or swimming pool.

Do not locate the appliance immediately below a fixed socket outlet or connection box.

This appliance can be used by children aged from 8 years and above and persons with reduced physical, sensory or mental capabilities or lack of experience and knowledge if they have been given supervision or instruction concerning use of the appliance in a safe way and understand the hazards involved. Children shall not play with the appliance. Cleaning and user maintenance shall not be made by children without supervision.

Children of less than 3 years should be kept away unless continuously supervised.

Children aged from 3 years and less than 8 years shall only switch on/off the appliance provided that it has been placed or installed in its intended normal operating position and they have been given supervision or instruction concerning use of the appliance in a safe way and understand the hazards involved. Children aged from 3 years and less than 8 years shall not plug in, regulate and clean the appliance or perform user maintenance.

CAUTION: Some parts of this product can become very hot and cause burns. Particular attention has to be given where children and vulnerable people are present.

Do not use this appliance in series with a thermal control, a program controller, a timer or any other device that switches on the heat automatically, since a fire risk exists when the heater is accidentally covered or displaced.

Ensure that furniture, curtains or other combustible material are positioned no closer than 1 meter from the appliance.

In the event of a fault unplug the appliance.

Unplug the appliance when not required for long periods.

Although this appliance complies with safety standards, we do not recommend its use on deep pile carpets or on long hair type of rugs.

The appliance must be positioned so that the plug is accessible.

If the supply cord is damaged it must be replaced by the manufacturer or service agent or a similarly qualified person in order to avoid a hazard.

Keep the supply cord away from the front of the appliance.

WARNING: In order to avoid overheating, do not cover the appliance. Do not place material or garments on the appliance, or obstruct the air circulation around the appliance.

The appliance carries a DO NOT COVER warning symbol. 

This appliance is not equipped with a device to control the room temperature. Do not use this appliance in small rooms when they are occupied by persons not capable of leaving the room on their own, unless constant supervision is provided.

General Information

Only use filtered/decalcified water in this appliance.

Unpack the appliance carefully and retain the packaging for possible future use, in the event of moving or returning the fire to your supplier.

Always ensure that the appliance is sitting on a level surface.

The appliance is a flame effect only.

The appliance is designed to be built into a surround or built into a wall.

Please note: Used in an environment where background noise is very low, it may be possible to hear a sound which is related to the operation of the flame effect. This is normal and should not be a cause for concern.

Once installed, never move this appliance or lay on its back, without draining the water from sump and water tank.

The water tank, sump, sump lid, tank cap and air filters must be cleaned once every week, particularly in hard water areas.

If you intend not using the appliance for longer than a week, drain the water from sump and water tank and dry the sump.

The sump and the water tank in this product are treated with a biocidal product, Silver Biocide. This conforms to the latest relevant ISO standard

As this product contains and utilises water as an aspect of its operation, the adherence to the cleaning requirement as detailed within the instructions is necessary to ensure that risk/s through bacterial proliferation are minimised. It is additionally recommended that if this unit is connected to a water supply, that it becomes included within any Legionella assessment. Please refer to the Maintenance section in the following instruction booklet for details on the cleaning

Do not drink the water from the sump or from the water tank(s).

Installation Instructions

This section describes how to install and set up your fire.

Before you start:

Ensure that all packing items are removed (read any warning labels carefully) and retain all packing for possible future use.

Before connecting the appliance, check that the supply voltage is the same as that stated on the appliance.

CONNECTIONS REQUIRED IN ADVANCE OF INSTALLATION

Electrical Connection

Please ensure a 230V / 16A power socket is located within 1m of the product. The electrical connection should be accessible during product installation so that the connection can be made to the product easily.

BUILDING THE PRODUCT SURROUND/ENCLOSURE

This product can be built into a wall, surround or structure. Please take note of the product dimensions (Fig.1) and build your wall, surround or structure accordingly. Suitable clearance should be provided to allow the product to be installed easily.

You are required to leave a minimum of 400mm from the base of the fuel bed to any shelf/enclosure above the product (Fig. 2). This will allow enough space above the product to allow the flame effect to form fully and not to be obstructed. When determining a location for the product, ensure that the unit will not be susceptible to drafts, vents, ceiling fans and other air currents. Similar to a candle, large movements of air will affect the unit's ability to create and maintain the flame effect. If the desired location is susceptible to significant air movement, i.e. air vents, the different installation options illustrated in Fig 2 can be used.

VENTILATION

This product needs free ventilation from underneath to operate correctly. There are slots on the underside of the product to allow this free air through the product. The free ventilation helps keep the electronic components cool and allows the mist to rise and leave the product. Please see Fig 3 & 4 for examples of the required ventilation. Please take note of the requirement for a ventilation opening on the shelf where the product sits, to allow a clear path for the air to get to the product.

CAS500R Free Ventilation Area: Minimum 210cm²

CAS1000R Free Ventilation Area: Minimum 420cm²

ELECTRICAL CONNECTION

Plug the fire into a 16amp/230 Volt outlet. Be sure to have access to the plug after installation to allow for disconnection. Ensure that the supply cable exits at the back of the fire at the right or left hand corner to suit your supply socket location and is not trapped under the fire such that it might cause it to be damaged.

The appliance can be connected to the fixed wiring of the premises through a suitable connection box positioned adjacent to the appliance. This electrical installation must be carried out by a competent electrician and be in strict

accordance with the current I.E.E regulations for Electrical Equipment in Buildings.

The electrician can remove the supplied plug by the following;

1. Lift off the fuelbed and put switch 'A' into the off position (Fig 26).
2. Ensure that the appliance is unplugged.
3. Lift off the access cover by removing the retaining screw (Fig 5).
4. Unscrew and remove the Live, Neutral and Earth wires (Fig 6A)
5. Unscrew the cable clamp (Fig 6B) and remove the supply cord.
6. The electrician can then connect the wire from the appliance to the connection box (by following the steps above in reverse) ensuring that it incorporates a double pole isolating switch, having a contact separation of at least 3mm. Brown - Live (L), Blue - Neutral (N) and Green/Yellow - Earth (E)

INSTALLING THE PRODUCT INTO SURROUND/ENCLOSURE

Once your enclosure has been built to the required dimensions and the electrical connection has been installed, follow the steps below to install your product.

1. Sit the product on the constructed base, ensuring the cable is accessible and not caught under the product.
2. Ensure the product is at the correct height to suit the installation and ensure it is adequately level. This can be done by adjusting the adjustable feet with a flat head screwdriver. (Fig 7) The levelness of the product can be verified by checking the on-board spirit level which is located on the metal base towards the back of the fire (Fig 8).
3. Once the product is at the correct height and is level, centre the product within the opening. If using the LED log fuel bed (which is wider than the product), this can be done by fitting the fuel bed to the product. The fuel bed will centre itself within the opening and its guides will centre the product underneath (Fig 9).
4. With the product in its final position, remove the fuel bed and screw the product to the surround using the four fixing holes shown in Fig 10.

COMMISSIONING/INITIAL PRODUCT START-UP

Connecting the Receiver/Tethered Remote

With the fuel bed removed, insert the 3.5mm jack of the Bluetooth receiver into the socket at the back of the appliance (Fig 11). It is important to ensure that the jack is pushed fully into the socket. Failure to fully insert the jack will prevent the product from functioning correctly. The receiver has a cable length of 1.4m which will allow you position it anywhere around the product. If you prefer to hide it, the receiver can be placed inside the surround/wall. Please ensure that the receiver is not enclosed in metal, concrete or any other dense material, this will affect the signal from the remote control.

Filling the Water Tank

Before powering on the product for the first time, ensure that a full water tank has been placed on the product. Remove the water tank from its location on top of the sump (Fig 12A) and open it by unscrewing the orange cap (Fig 12B). The tank should be filled with filtered/decalcified water only. When the tank is replaced on top of the sump, it will take about one minute for the tank to empty into the sump. Allow the sump to fill fully before switching on the product. Once filling is complete, the tank can be refilled and replaced on top of the sump. This will allow for the maximum capacity of water to be stored in the product.

Installing the Log Fuel Bed (If Supplied)

The product is supplied with a 'metal fuel bed' fitted. If you have chosen to operate your product with a log fuel bed, remove this metal fuel bed and retain it for future use (Fig. 13). Follow the steps below to install the log fuel bed.

1. Gently lift the LED Log fuel bed out of its packaging. CAUTION: The fuel bed weighs 5kg. Be sure to only lift the fuel bed by the two centre logs (Fig. 14).
2. Place the fuel bed on top of the appliance, there are 4 plastic guides under the fuel bed to help locate it (Fig.9). Please note the fuel bed can be placed front to back or back to front on the product.
3. Once the fuel bed is in place, remove the small loose log (Fig 15). This small log is secured with magnets and should easily lift off the fuel bed.
4. Locate the DC jack under the small log and connect it to the corresponding DC jack located on the product through the hole in the fuel bed (Fig.16).
5. Each log fuel bed is supplied with a loose non LED log. For single CAS500R installations, this can be placed on top of the fuel bed or stored away with the packaging. For CAS1000R or multiple product installations, the loose log can be placed on the join in the centre between two fuel beds (Fig 17).

MULTIPLE PRODUCT INSTALLATION (DAISY CHAINING)

Power Connections

Both the CAS500R and CAS1000R products can be installed side by side to elongate the flame effect. When supplying power to multiple products, ensure the maximum wattage of the combined products does not exceed the rated capacity of the MCB (Minature Circuit Breaker) in the circuit.

Multiple Product Installation

Follow steps 1-4 in "Installing the Product into Surround/Enclosure" to fit the first product. It is important that the first

product is orientated so that the side of the product with the slots is left free and not connected to first end of the installation (Fig 18).

1. When the first product is installed and securely fixed, prepare the second product by unscrewing the joining screws (Fig 19A) and screwing them into the opposite side of the metalwork (Fig 19B). Please note, these screws should not be fully tightened and 5-10mm of thread should be left protruding from the edge of the product.
 2. Fit the second product beside the first product, ensuring the protruding screws of the second product engage with slots of the first product. (Fig 20)
 3. Ensure the second product is at the correct height to match the first product and ensure it is adequately level. This can be done by adjusting the adjustable feet with a flat head screwdriver. (Fig 8) The levelness of the product can be verified by checking the on-board level (Fig 9)
 4. Tighten the screws of the second product so that it joins tightly with the first product.
- Additional products can be fitted to the second product by following steps 1-4 above.

Multiple Product Control

Each product has been supplied with its own link wire in order to form a hardwire link between multiple products. Please follow the instructions below to link multiple products together.

1. Identify the 'master' product in the installation. It should be the product on the left hand side of the installation.
2. Connect the Bluetooth receiver to this product (CAS500 - Fig 21A, CAS1000 – Fig 22A). This will be the only Bluetooth receiver in the installation and will control the rest of the products in the installation. In an installation of both CAS500 & CAS1000 products, a CAS500 receiver (Fig 11) should be connected to the 'master' product.
3. In installations where a CAS500 is the 'master' product, connect the CAS500 link wire to the connector in the plastic top cover (Fig 21B). In installations where a CAS1000 is the 'master' product, connect the CAS1000 link wire to the 3.5mm jack which is housed in the plastic (Fig 22B).
4. Feed the wire through the hole in the metalwork and into the housing of the next product in the installation (Fig 23)
5. For a CAS500, plug the link wire into the 3.5mm jack housed in the plastic (Fig 24). For a CAS1000, plug the link wire into the 3.5mm jack housed in the plastic on the left hand side module (Fig 25).
6. Repeat steps 3-5 above in order to connect subsequent products in the installation.

Once set up, any command sent to the first product will be sent to all subsequent products. Flame height control and sound level control of the master product is matched for all subsequent products. If individual flame height control is required, this can be done by using the on board flame height controls on the product (Fig 26).

Additionally, the software of the product has been designed in such a way that when multiple products are connected to a main switch, products can be manually switched off and when switched back on they will operate in the same state as before they were switched off.

Operating the Product

This section describes how to activate your fire using either the manual controls or remote control.

MANUAL CONTROLS







The manual controls are located beneath the fuel bed. (Fig 26)

CAS500R

Mains Switch - Controls the electricity supply to the appliance. (Fig 26A)

Note: This switch must be in the 'ON' (I) position for the appliance to operate

Button Panel - Controls the functioning of the appliance. (Fig 26B)







-  is the on/standby button. Press it to turn on and off the flame effect. Turning it on will be indicated by a single beep and the main LED lights activating. Be careful not to look directly into the LED's as they can be very bright. Although the main LED lights operate immediately, a further 45 seconds of warm up time is required before the flame effect starts.
-  is the Pairing button. This will pair your remote control to the receiver. See 'Remote Control Operation' for details.
-  is the test mode button. This will be used by the manufacturer and the Service Engineer.
-  is the reduce flame button. Press this to reduce the height/intensity of your flame. You will hear an audible beep when you reach the minimum level.
-  is the increase flame button. Press this to increase the height/intensity of your flame. You will hear an audible beep when you reach the maximum level.
-  is the reduce fire crackling sound. Press this to reduce the volume of the crackling sound. The minimum volume for this is off
-  is the increase fire crackling sound. Press this to increase the volume of the crackling sound.

CAS1000R

Mains Switch - Controls the electricity supply to the appliance. (Fig 26A)

Note: This switch must be in the 'ON' (I) position for the appliance to operate





Button Panel 'C' Controls the functioning of the left side of product while Button Panel 'D' controls the functioning of the right side of the product. Please note the flame height and fire crackling noise can be controlled independently on each individual side of the product.

-  is the on/standby button. Press it to turn on and off the flame effect. Turning it on will be indicated by a single beep and the main LED lights activating. Be careful not to look directly into the LED's as they can be very bright. Although the main LED lights operate immediately, a further 45 seconds of warm up time is required before the flame effect starts.
-  is the pairing button. This will pair your remote control to the receiver. See 'Remote Control Operation' for details.
-  is the test mode button. This will be used by the manufacturer and the Service Engineer.
-  is the reduce flame button. Press this to reduce the height/intensity of your flame. You will hear an audible beep when you reach the minimum level
-  is the increase flame button. Press this to increase the height/intensity of your flame. You will hear an audible beep when you reach the maximum level.
-  is the reduce fire crackling sound. Press this to reduce the volume of the crackling sound. The minimum volume for this is off. You will hear an audible beep when you reach the minimum level.
-  is the increase fire crackling sound. Press this to increase the volume of the crackling sound. You will hear an audible beep when you reach the maximum level.





RECEIVER CONTROLS

The product can also be controlled using the receiver which is supplied with the product. (Fig 11)

CAS500R

-  is the on/standby button. Press it to turn on and off the flame effect.
-  is used to mute the fire crackling sound. Press this to turn on and off the crackling sound. The volume can be adjusted on the manual controls of the appliance. Please note that the mute setting will not be saved after a product restart. The crackling sound can be turned off completely by using the volume control buttons on the button panel to reduce the volume to its minimum setting. This minimum setting will be remembered after a product restart.
-  is the reduce flame button. Press this to reduce the height/intensity of your flame. You will hear an audible beep when you reach the minimum level.
-  is the increase flame button. Press this to increase the height/intensity of your flame. You will hear an audible beep when you reach the maximum level

CAS1000R

-  is the on/standby button. Press it to turn on and off the flame effect.
-  is used to mute the fire crackling sound. Press this to turn on and off the crackling sound. The volume can be adjusted on the manual controls of the appliance. Please note that the mute setting will not be saved after a product restart. The crackling sound can be turned off completely by using the volume control buttons on the button panel to reduce the volume to its minimum setting. This minimum setting will be remembered after a product restart.
-  is the reduce flame button. Press the reduce flame button on the second button row to reduce the height/intensity of the flame on the left hand side of the product. Press the reduce flame button on the third button row to reduce the height/intensity of the flame on the right hand side of the product. You will hear an audible beep when you reach the minimum level.
-  is the increase flame button. Press the increase flame button on the second button row to increase the height/intensity of the flame on the left hand side of the product. Press the increase flame button on the third button row to increase the height/intensity of the flame on the right hand side of the product. You will hear an audible beep when you reach the maximum level.

REMOTE CONTROL



The remote control is supplied with 2xAAA batteries. Remove the battery cover from the underside of the remote control and after removing the batteries from the plastic wrapping fit them into place. Replace the battery cover. With the product powered off, a functional test can be carried out on the remote control by pushing any button and observing the blue LED at the top of the remote flashing with each button push.

Frequency band(s) this product operates in: 2.4GHz

Maximum radio-frequency power transmitter in the frequency band(s) this product operates in: 2.71dBm



Pairing the Remote Control

The remote control has wireless Bluetooth technology and needs to be paired to the receiver. This can be done by following the steps below.

1. Press the rocker switch to the on (I) position.
2. Press the  button on the Button Panel; the product will turn on.
3. Press the  button on the Button Panel, the LED's will start to slowly blink on and off.
4. Press the  button on the remote control; the product LEDs will flash quickly five times and the product will then automatically switch off. The remote control is now paired to the product and can be used to switch it back on.

The operation of the remote control is the same as described in 'Receiver Controls'. You can pair multiple products to the one remote control by repeating the pairing operation as above on your subsequent products. Please note a maximum of six CAS500R/CAS1000R products can be paired to the one remote control.

GETTING THE DESIRED FLAME EFFECT

1. Switch the appliance on by pressing the main switch to the on position and pressing the  button. The flames will start after 45seconds.
2. Press the  and  buttons to adjust the flame to your desired level. Please give the flame generator time to react to the changes you make.

Once you have made your adjustments to both the flame height and crackling sound, the appliance will keep these settings even if you power off the appliance by either the on/standby button or by the main switch. The next time you switch on the appliance, it will start up as normal, wait 45 seconds for the flames to start and then revert to the adjusted settings.

Nozzle Inserts

Nozzle inserts have been supplied and fitted to the nozzle opening. These inserts are used to alter the profile of the flame effect. These inserts can be removed if a different flame profile is preferred. In addition to these inserts, inserts for blocking the flame in certain areas have also been supplied. To fit these inserts, remove the existing inserts that have been supplied and fitted to the product. Break the blocking inserts into the required length. Snap the inserts into the nozzle opening in the desired location. See Fig 27 for further details.

LOW WATER / REFILLING THE WATER TANKS

When the water tanks have emptied and the water level in the product is getting low, the product will flash its LEDs twice and beep twice. The product will operate for a further 15 minutes before beeping once and switching into low water mode. For products being operated with the LED log fuel bed, only the fuel bed will remain illuminated while in low water mode. At this point, the product can either be switched into stand-by mode using the remote control or Bluetooth receiver or the product can be refilled with water. Refilling the product with water will cause the product to restart automatically.

To refill the tank, remove the fuel bed and remove the water tank from its position on top of the sump. Refill the water tank using filtered/decalcified water only. The tank can then be replaced on top of the sump. If the product was not switched into stand-by mode after experiencing low later, the product will restart automatically after about 20 seconds of refilling.

Please note that for a CAS1000R product, the side of the product that is experiencing low water will flash twice and beep twice. The water tanks on both sides of the CAS1000R product can be refilled at this point as it is likely that they should both be empty or near empty.

Maintenance

GENERAL TIPS

Only use filtered/decalcified water in this appliance.

Always ensure that the appliance is sitting on a level surface.

If you intend not using the appliance for longer than a week, remove and empty the sump and water tank.

Once installed, never move this appliance or lay on its back, without draining the water from sump.

CLEANING

Warning – Always press Switch 'A' to the 'OFF' (0) position (Fig 26) and disconnect from the power supply before cleaning the fire.

We recommend cleaning the following components once every week, particularly in hard water areas:

Sump, Nozzle, Tank cap and seal, Air filter

For general cleaning use a soft clean duster – never use abrasive cleaners.

To remove any accumulation of dust or fluff, the soft brush attachment of a vacuum cleaner should occasionally be used.

Sump

1. Press Switch 'A' to the 'OFF' (0) position (Fig 26)
2. Gently lift off the fuel bed and place it aside.
3. Remove the water tank from its position on top of the sump.

4. Disconnect the electrical connector to the transducers, located on the right side of the sump. (Fig 28).
5. There are two orange clips holding down the nozzle on the sump; one on the left and one on the right hand side of the nozzle. On the left side, press in the clip with one hand and with the other lift the nozzle out of the clip. Repeat this for the right side (Fig 29). The nozzle can now be lifted up and placed aside (Fig 30).
6. Gently lift up the sump (Fig 31), taking care to keep it level so as not to spill any water. Sit the sump in the sink.
7. Carefully empty the sump into the sink taking note that the transducer is held in place by a retaining clip.
8. Put a small amount of washing up liquid into the sump, and using a soft brush, gently clean all surfaces in the sump and gently clean the transducer including the cone and metal discs located in the top grooved surface.
9. When cleaned, thoroughly rinse the sump with clean water to remove all traces of washing up liquid.
10. Clean the nozzle with a soft brush and flush out thoroughly with water.
11. Reverse the above steps 1 – 6 to reassemble.

Transducer

The transducer is a consumable item and may need to be replaced through time, depending on its usage. Replacement transducers can be purchased from our your dealer. The transducer is fixed in the sump with a plastic clip. If you need to replace your transducer:

1. Follow the steps 1-5 in the CLEANING - Sump section under 'Maintenance' to gain access to the transducer.
2. Press the clip back and lift the transducer upwards out of its holder.
3. Place the new transducer into the sump, ensuring the its cable does not sit over the cone.
4. Reverse the above steps to reassemble the nozzle and sump.

Air Filter

1. Gently lift out the fuel bed and place it aside.
2. Gently slide the air filter upwards out of its plastic holder. (Fig 32)
3. Gently rinse with water in the sink and dry with fabric towel.
4. Replace the filter making sure that the coarse black filter is facing outwards.
5. Replace the fuel bed.

Additional Information

AFTER SALES SERVICE

Your product is guaranteed for two years from the date of purchase. Within this period, we undertake to repair or exchange this product free of charge (excluding transducer discs & subject to availability) provided it has been installed and operated in accordance with these instructions. Your rights under this guarantee are additional to your statutory rights, which in turn are not affected by this guarantee.

RECYCLING



At the end of the electrical products useful life it should not be disposed of with household waste. Please recycle where facilities exist. Check with your Local Authority or retailer for recycling advice in your area.

PATENT / PATENT APPLICATION

Products within the Optimyst range are protected by one or more of the following patents and patent applications:

Great Britain GB2460259B, GB2475794B, GB2418014, EP2029941, GB2436212, GB2402206B

United States US8413358, US8136276, US7967690, US8574086

Russia RU2434181

European EP2029941, EP2315976, EP1787063 (A1), EP2388527, EP2029941,

China CN101883953A, CN102105746A, CN101057105 (A), CN101438104

Australia AU2009248743A1, AU2007224634

Canada CA2725214, CA2579444, CA2645939

South Africa ZA2008/08702

Mexico MX2008011712

South Korea KR101364191

Japan JP5281417, JP5496291

Brazil BRP10708894

India 4122/KOLNP/2008

New Zealand NZ571900

Troubleshooting

| Symptom | Cause | Corrective Action |
|---|--|--|
| Product will not operate. | Electrical connection issue Low water reading | Ensure product has working electrical connection. Refill the water tank(s) of the product. See "Low Water / Refilling the Water Tanks" above. |
| Product will not operate. The LED fuel bed only operates. | Low water reading Product is not level | Refill the water tank(s) of the product. See "Low Water / Refilling the Water Tanks" above. Ensure the product is level by checking the on-board level (Fig 8). |
| LEDs blink twice and product beeps twice | Product is approaching low water | Refill the water tank(s) of the product. See "Low Water / Refilling the Water Tanks" above. |
| Little or No Mist Generation | Transducer not operating correctly Transducer is dirty Transducer is not sitting correctly in sump Fan is obstructed or blocked Nozzle is not on sump correctly Nozzle is blocked | Check operation of transducer Clean sump and transducer thoroughly Switch off product, take nozzle off sump and ensure transducer is fitted in sump correctly Remove air filter and clean. Ensure it is placed back in product correctly. Ensure Nozzle is sitting on sump correctly Clean sump, transducer and nozzle thoroughly |
| The flame effect has too much smoke. | Flame effect setting is too high | Turn down the flame effect. Give the product time to adjust to the new setting |
| Bluetooth Receiver stops working | Loose connection | Check connection to jack (Fig 11) |
| Remote Control stops working | Bluetooth range issue Bluetooth Receiver connection is loose Remote control batteries need replacing | Check positioning of Bluetooth Receiver. Ensure it is not encased in metal or concrete. Check connection to jack (Fig 11) Replace batteries with two new AAA batteries |

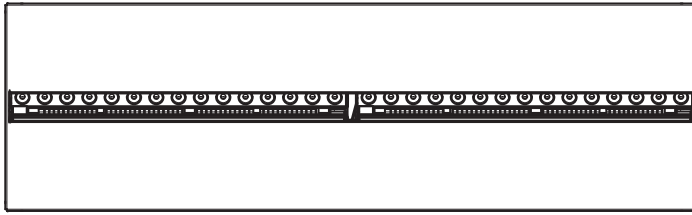

| MODEL | DIM 'A' |
|----------|---------|
| CAS500R | 508mm |
| CAS1000R | 1017mm |

| FUEL BED | DIM 'B' |
|----------|---------|
| METAL | 304mm |
| LOG | 354mm |

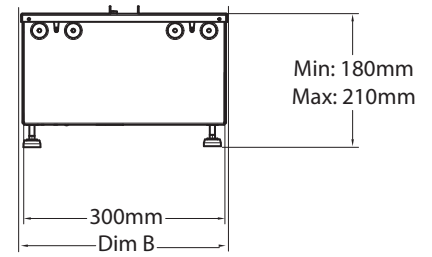
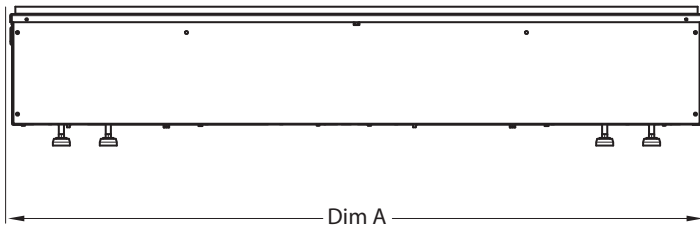

Fig.1

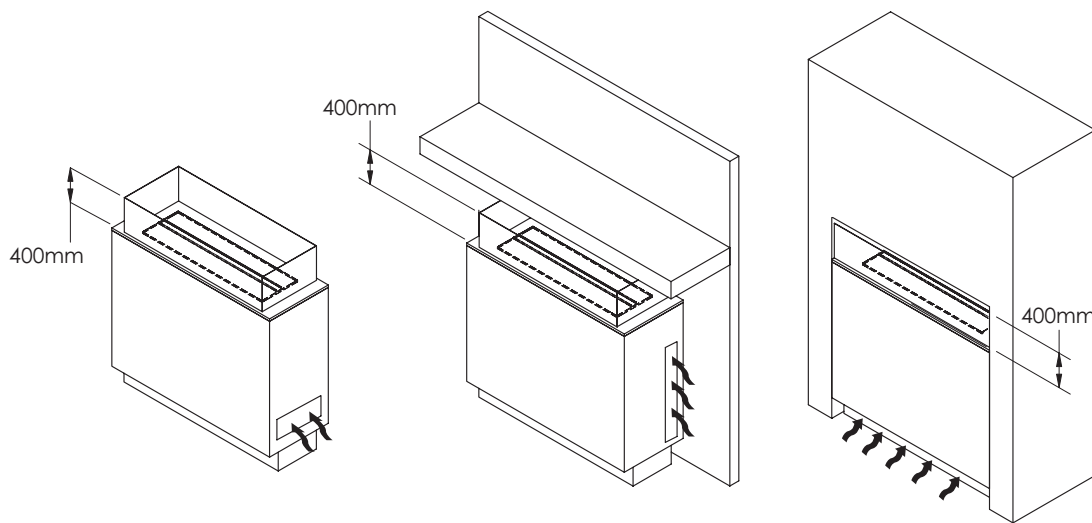
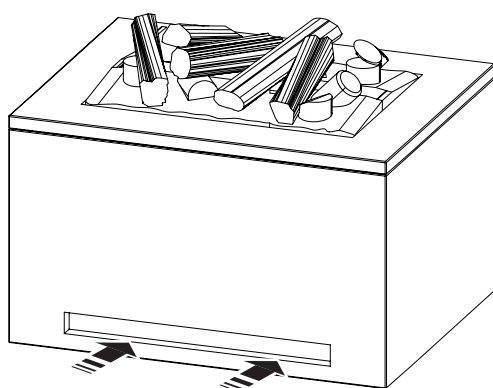
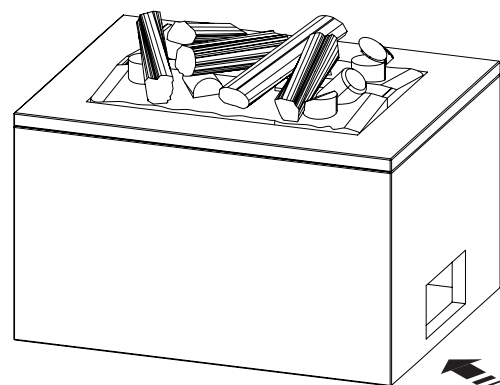

Fig.2



≈ >210cm²
Eg. 42cm x 5cm



≈ >210cm²
Eg. 14.5cm x 14.5cm

Fig.3

Fig.4

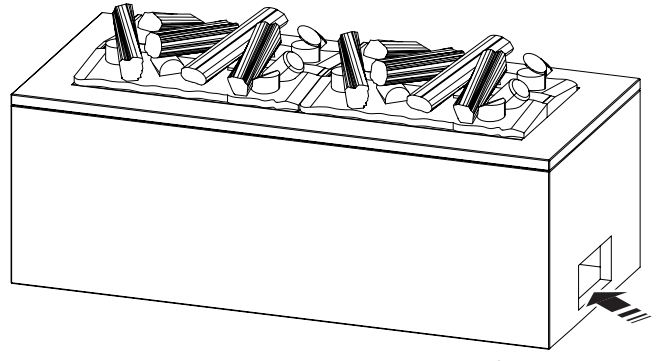
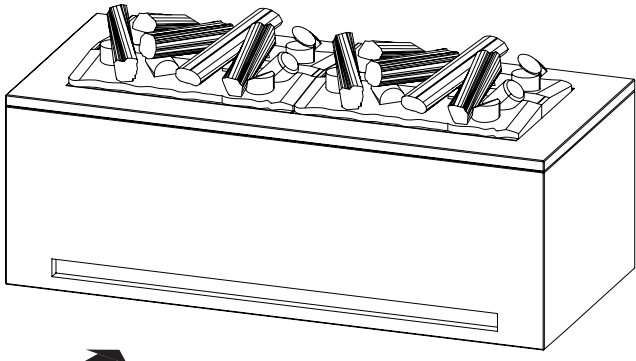

≈ >420cm²
Eg. 84cm x 5cm

≈ >420cm²
Eg. 20.5cm x 20.5cm

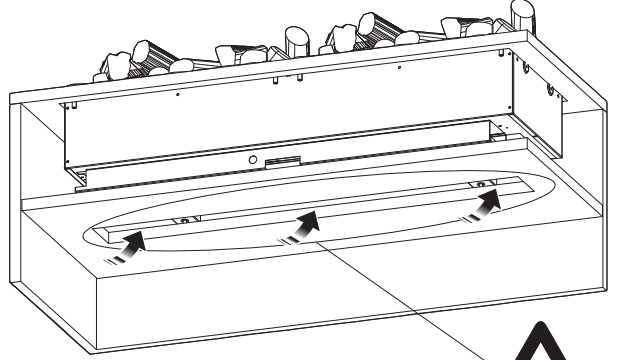
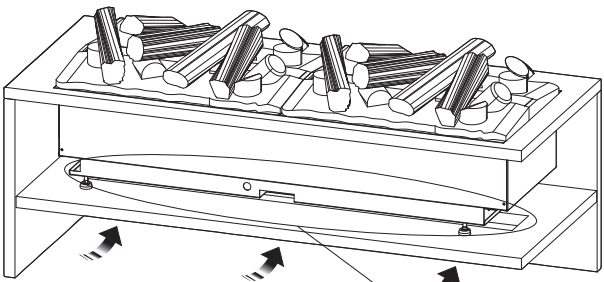

≈ >420cm²
Eg. 84cm x 5cm

≈ >420cm²
Eg. 84cm x 5cm

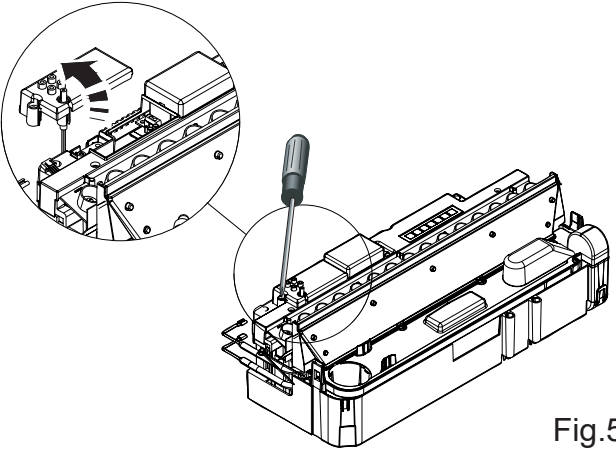

Fig.5

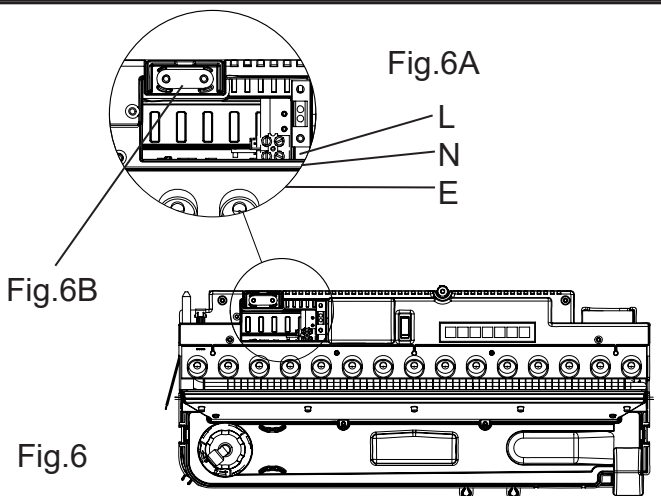

Fig.6B

Fig.6A

Fig.6

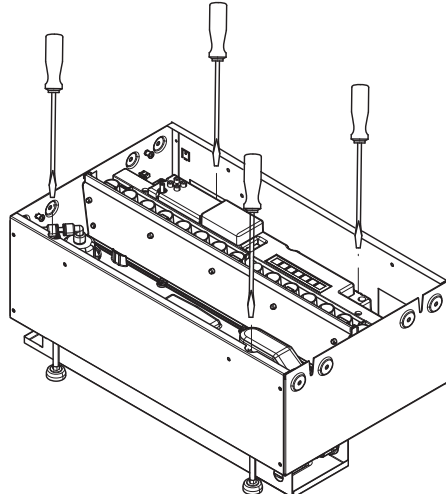
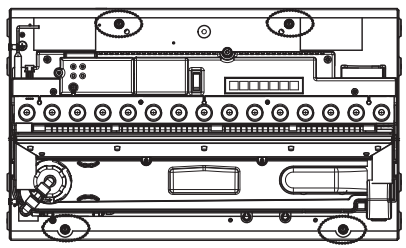

Fig.7

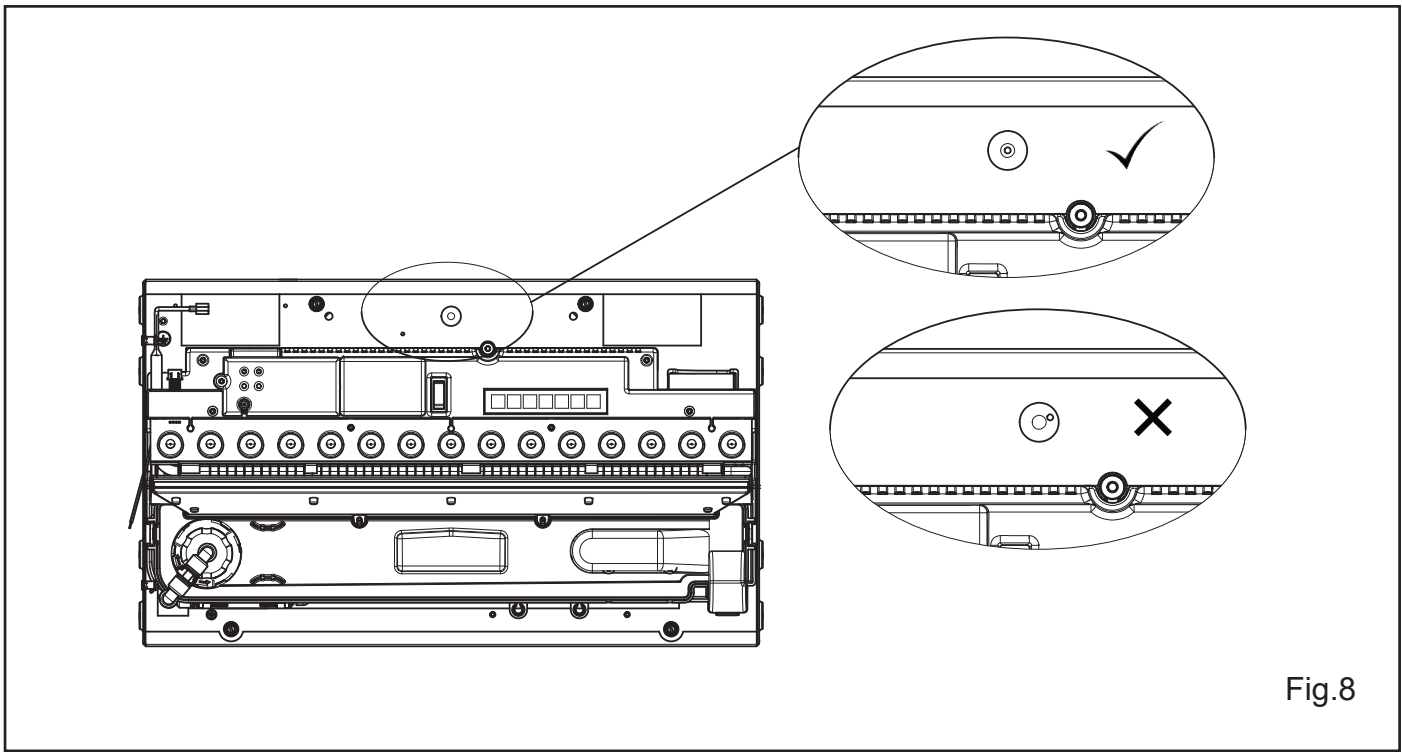

Fig.8

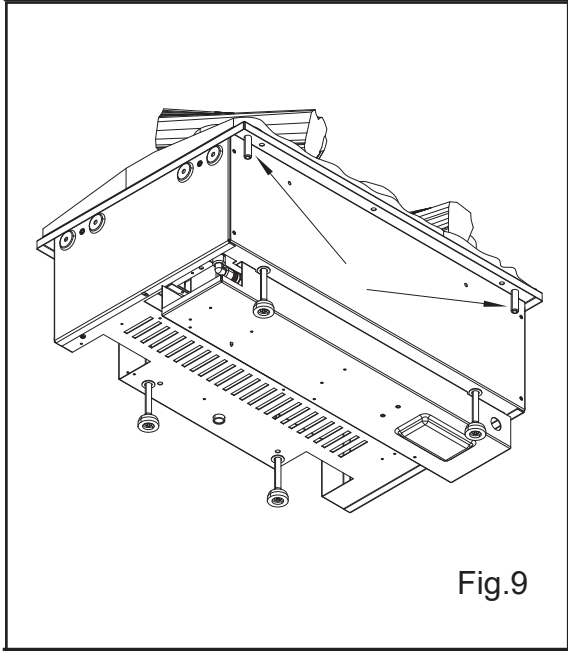

Fig.9

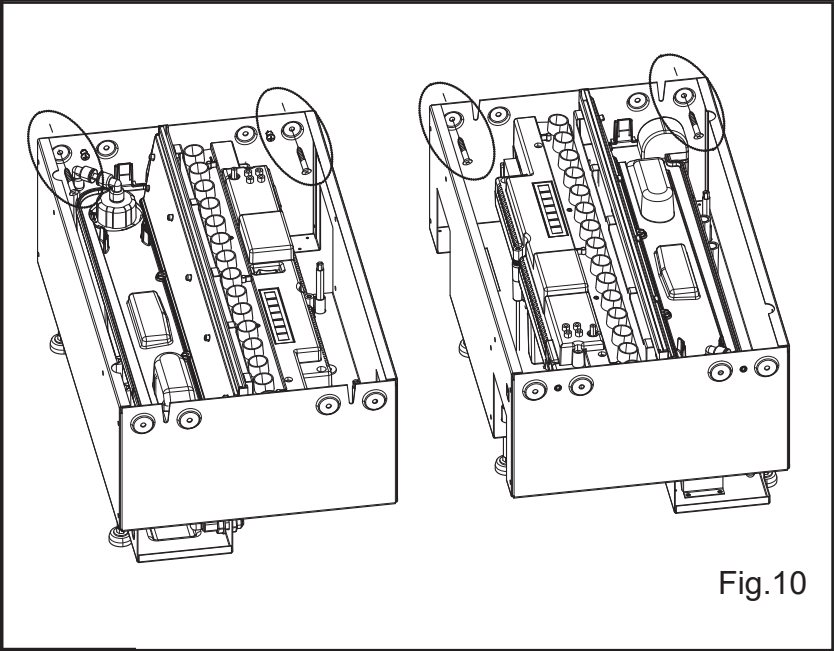

Fig.10

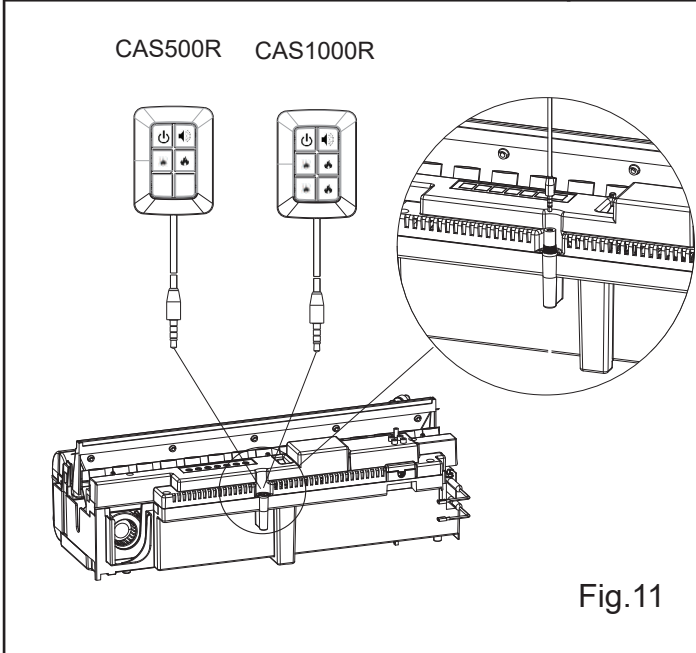

Fig.11

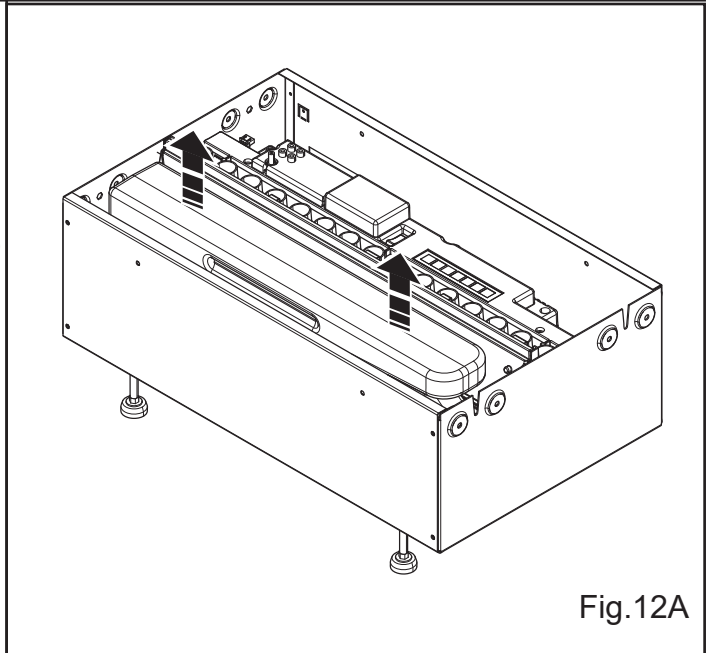

Fig.12A

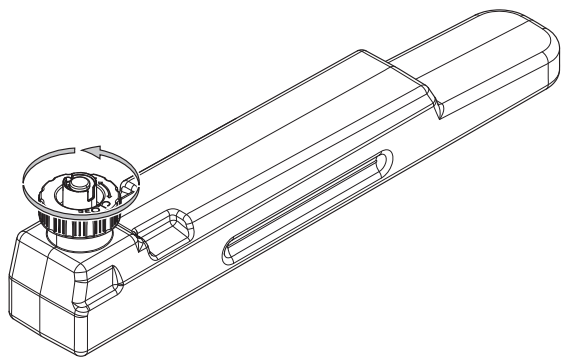

Fig. 12B

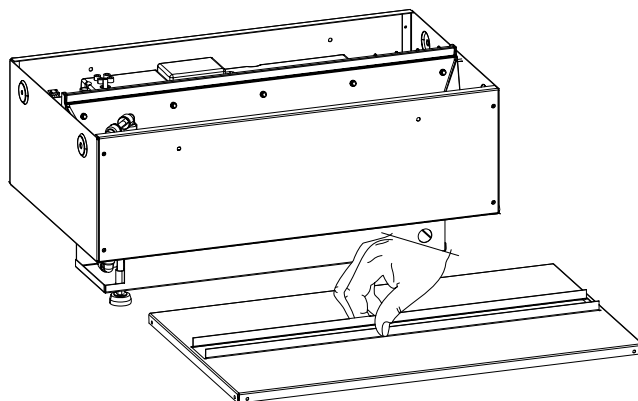

Fig. 13

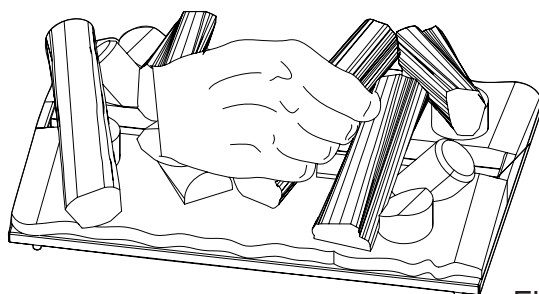

Fig. 14

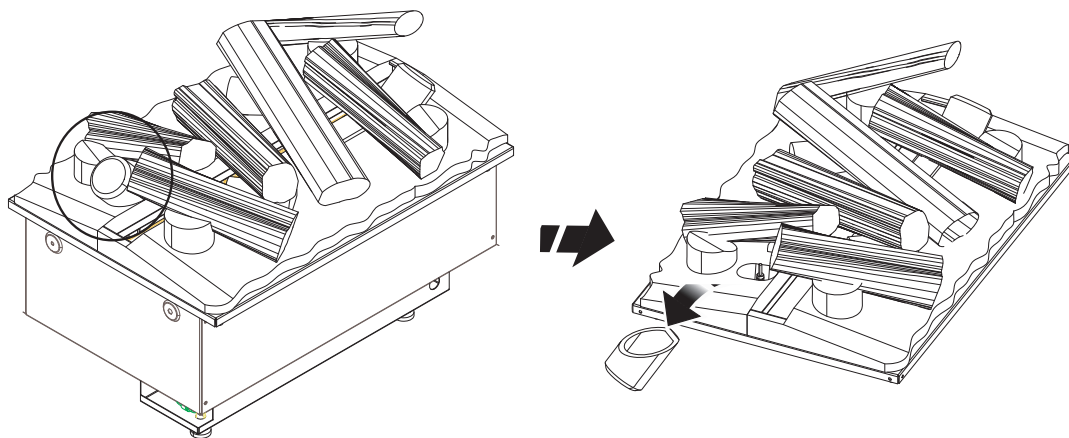

Fig. 15

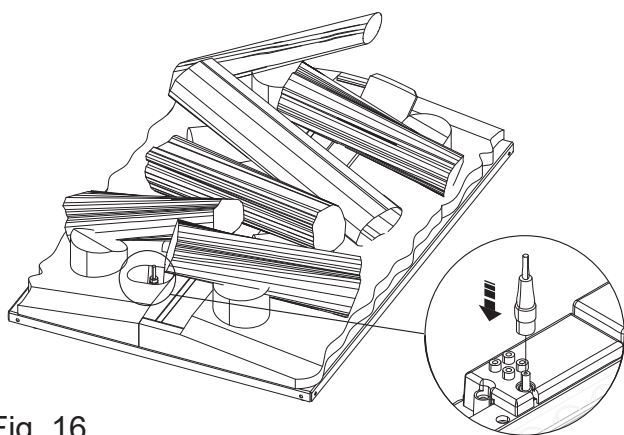

Fig. 16

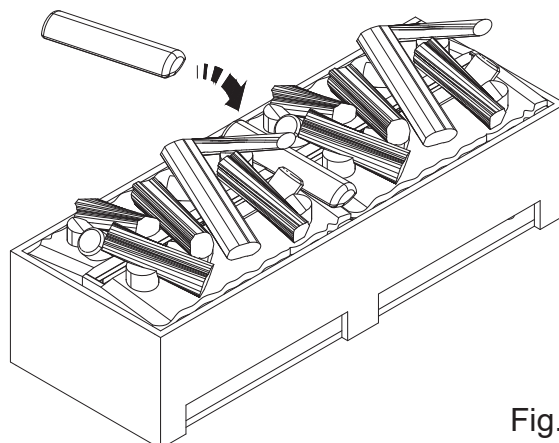

Fig. 17

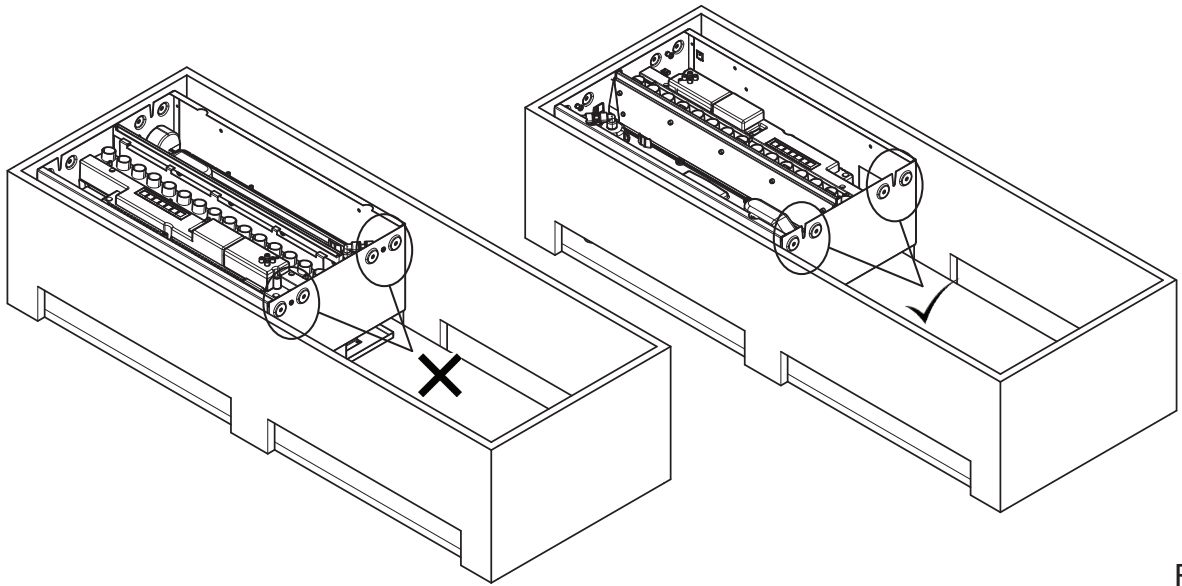

Fig. 18

Fig. 19A

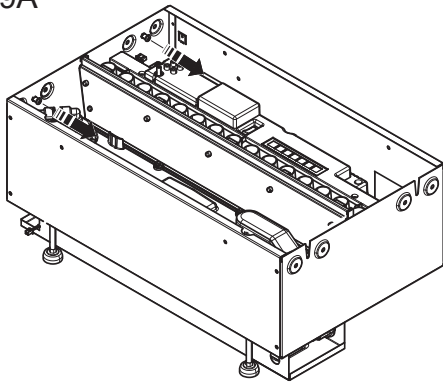

Fig. 19B

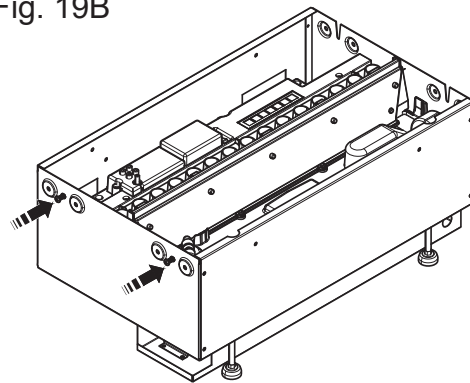

Fig. 19

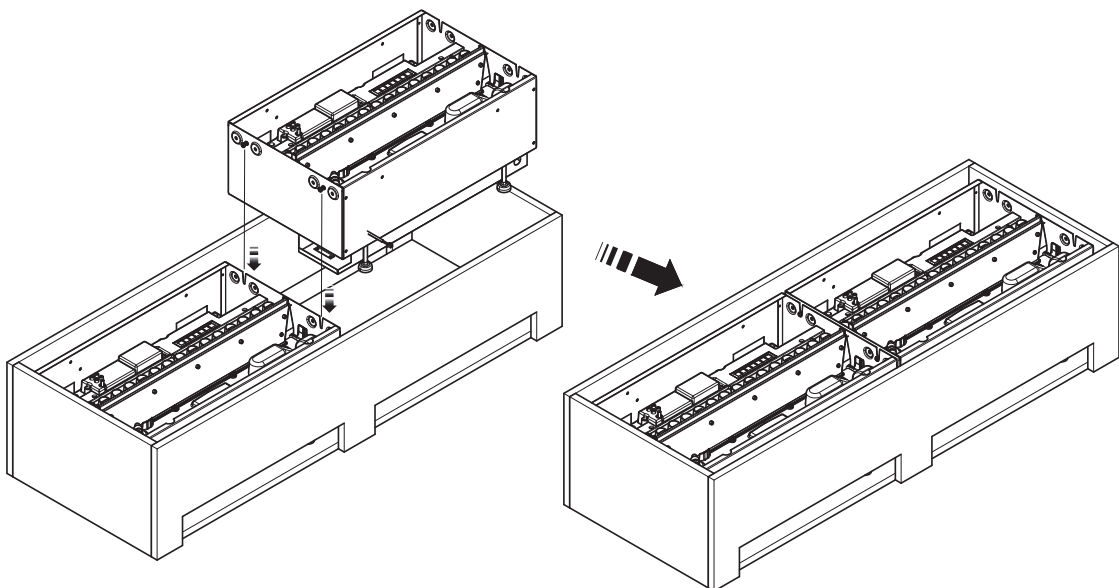
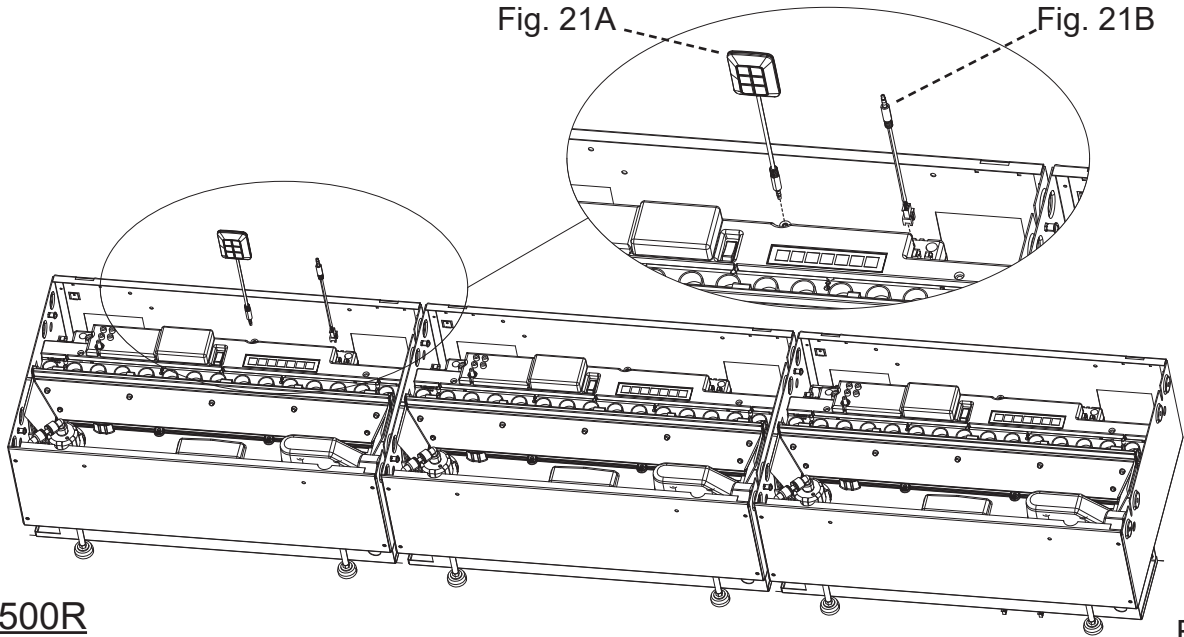

Fig. 20

Fig. 21A

Fig. 21B



CAS500R

Fig. 21

Fig. 22A

Fig. 22B

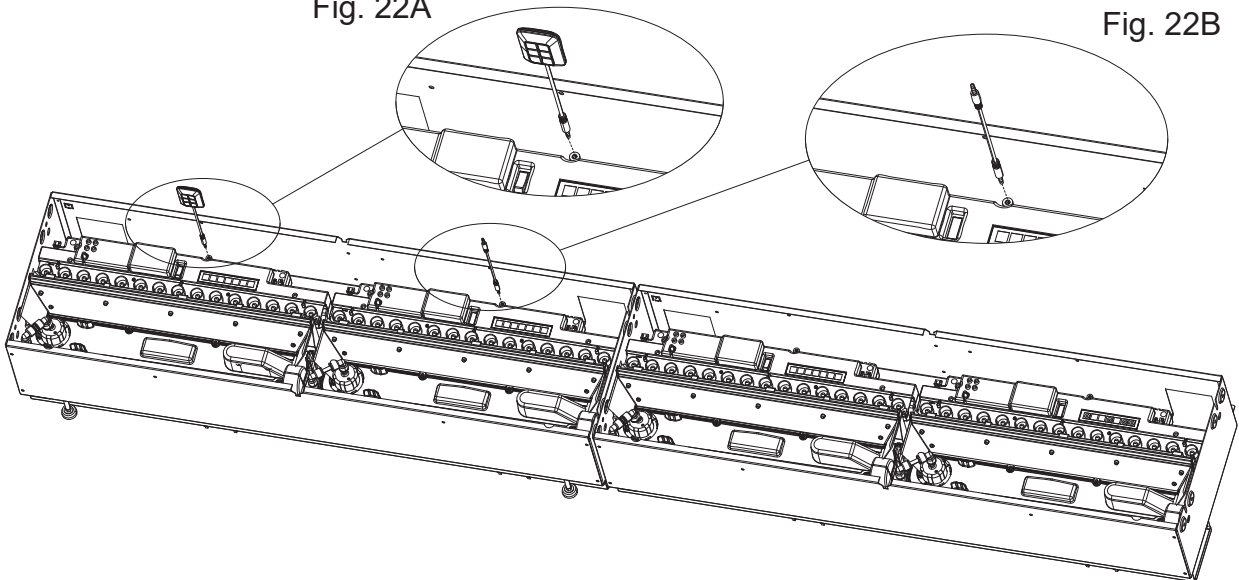

CAS1000R

Fig. 22

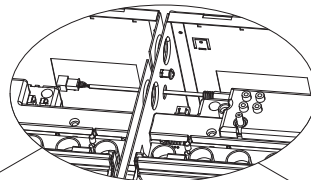

CAS500R & CAS1000R

Fig. 23

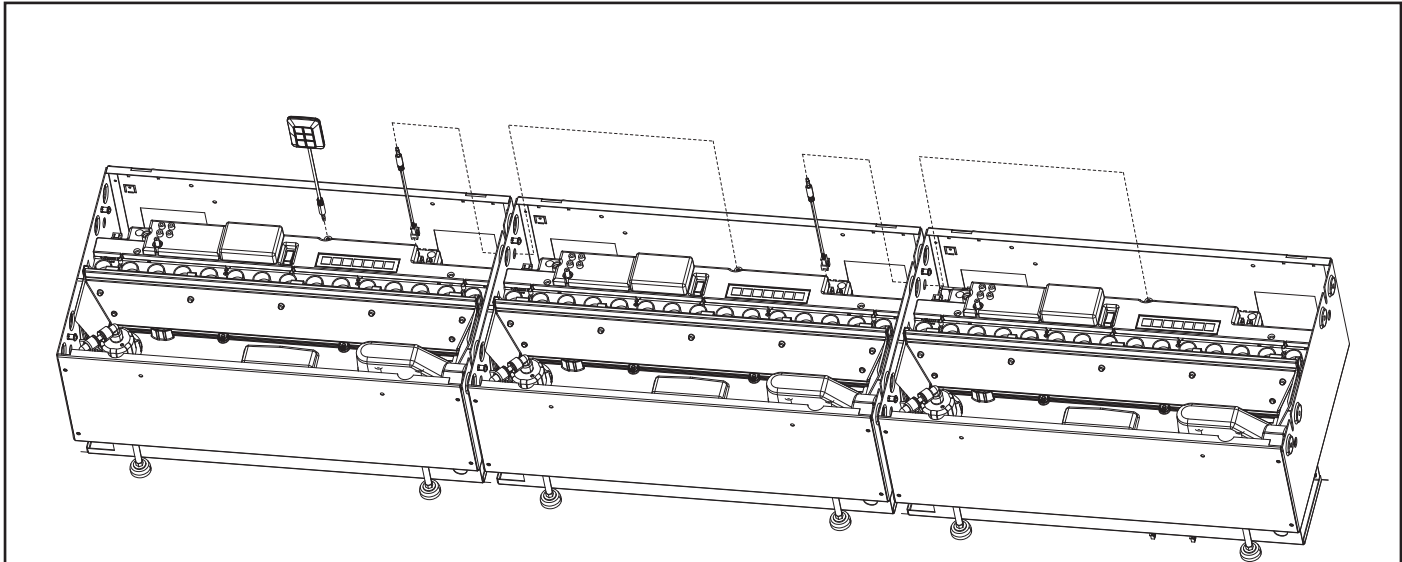

CAS500R

Fig. 24

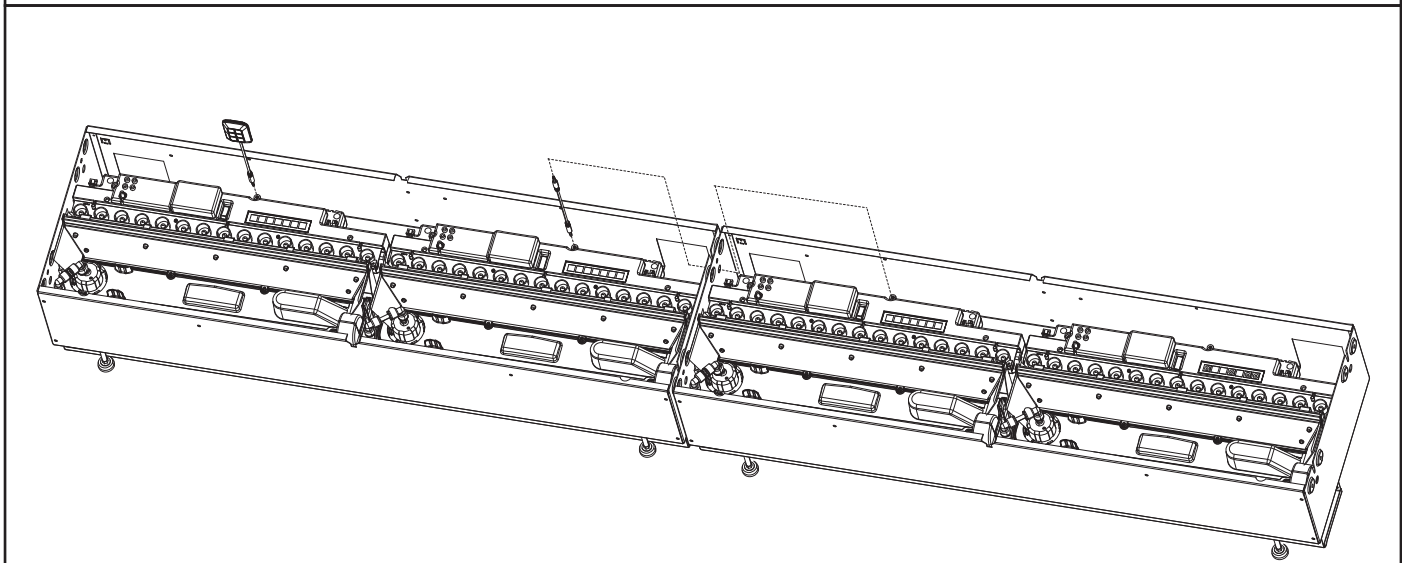

CAS1000R

Fig. 25

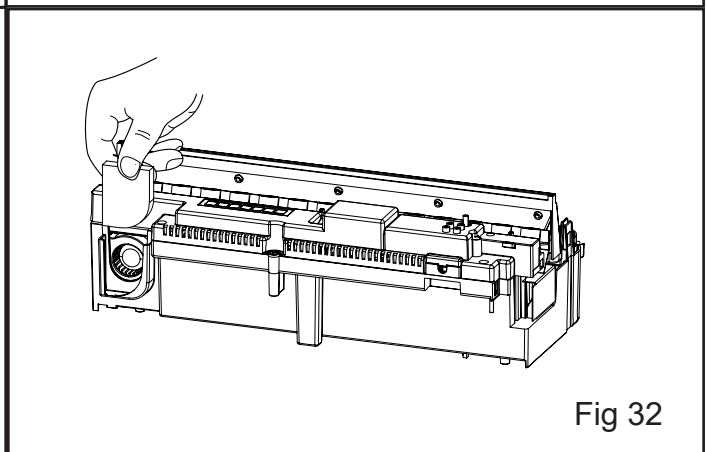
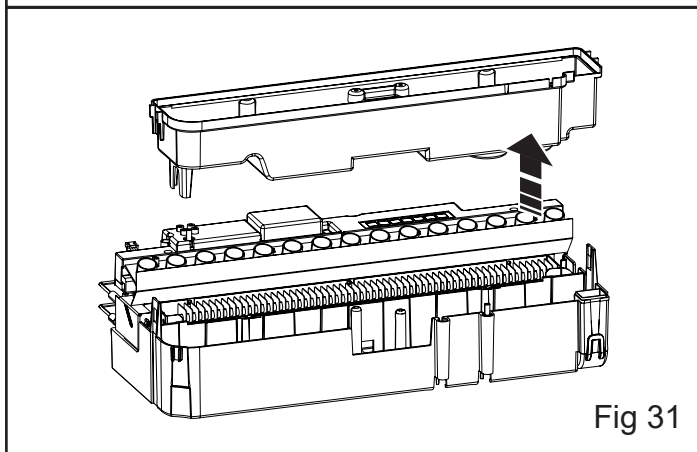
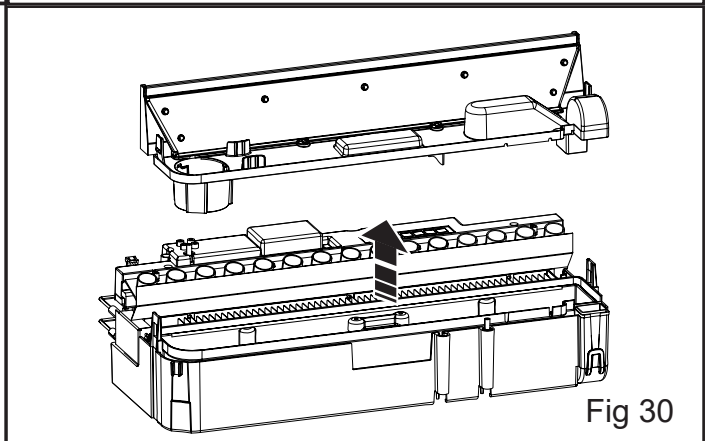
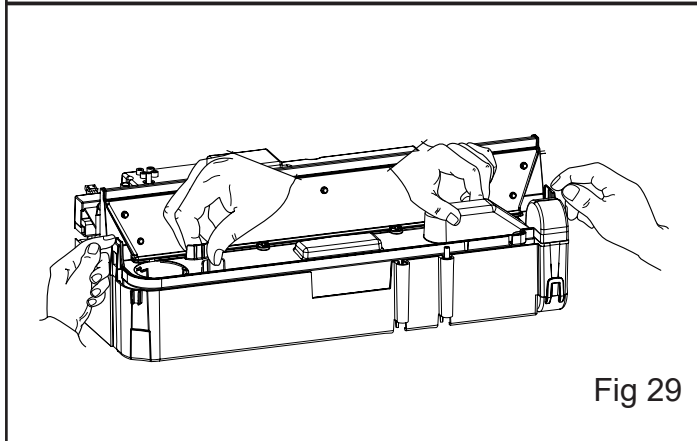
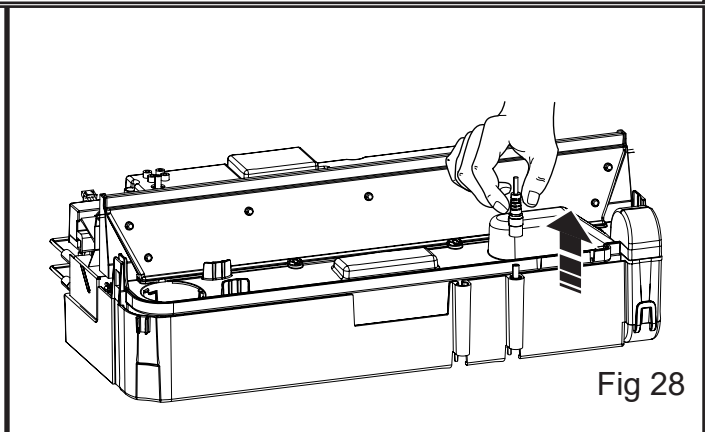
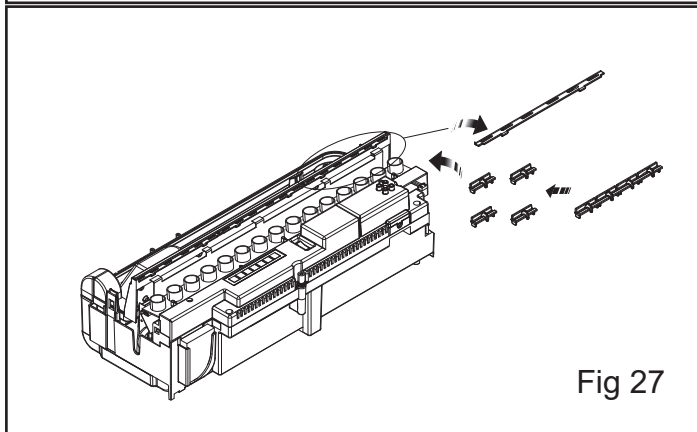
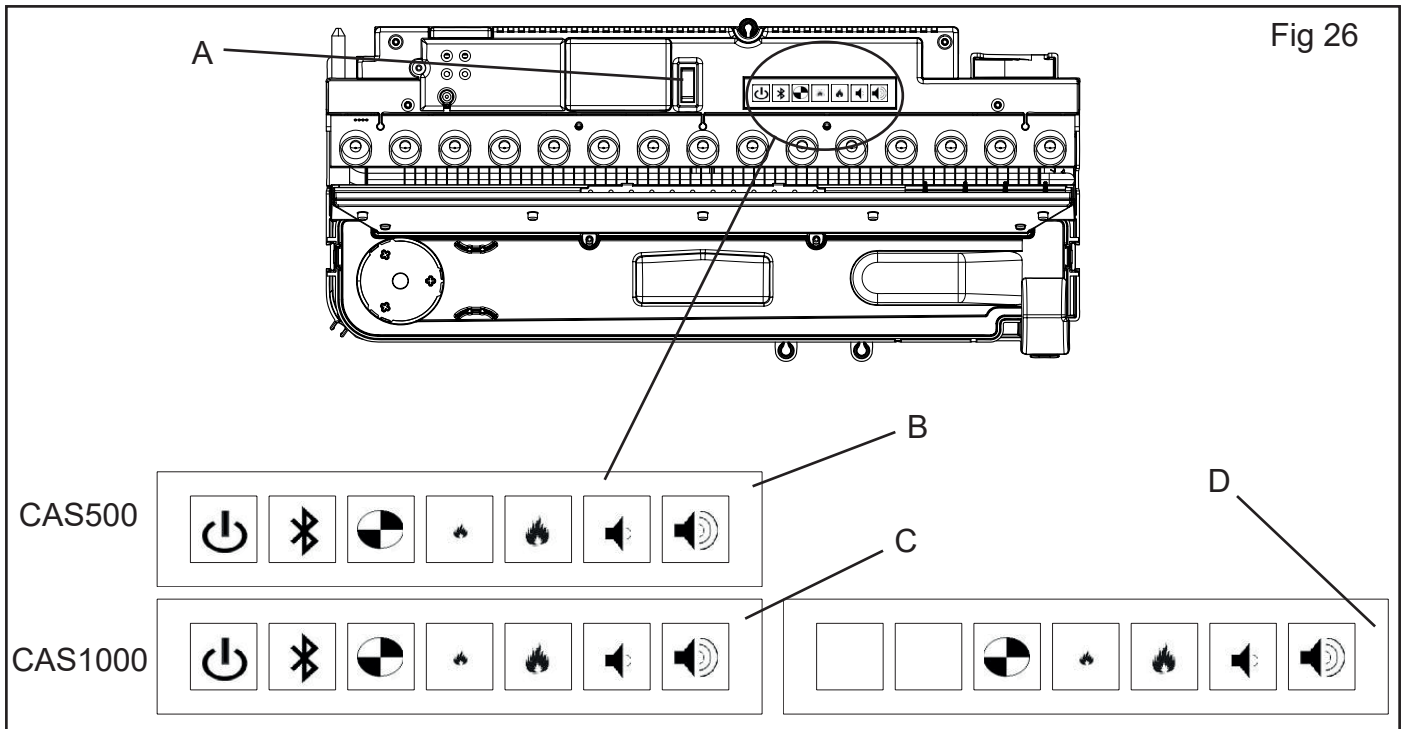

OPTIMYST is a trade mark of Glen Dimplex Heating and Ventilation.

DIMPLEX.
MILLBROOK HOUSE
GRANGE DRIVE
HEDGE END
SOUTHAMPTON
SO30 2DF

TEL: 0344 879 3588
WEBSITE: www.dimplex.co.uk
Republic of Ireland Tel. 01 8424833

© Glen Dimplex Heating and Ventilation,
All rights reserved. Material contained in this publication may not be reproduced in whole or in part, without prior permission in writing of Dimplex.