

# INSTALLATION & USER INSTRUCTIONS

## HIGH EFFICIENCY GAS STOVE

# ekofires

Christchurch, Dorset BH23 2BT

Tel: 01202 588 638

Fax: 01202 499 639

www.ekofires.co.uk

e-mail: sales@ekofires.co.uk

### MODELS COVERED BY THESE INSTRUCTIONS

6010, 6020 FLUELESS STOVE



**MODEL SHOWN : EKO 6010 FLUELESS STOVE**

# 3 year guarantee



**IN THE UK ALWAYS USE A GAS SAFE REGISTERED ENGINEER TO INSTALL, REPAIR OR SERVICE THIS APPLIANCE**

Please note : Except where otherwise stated, all rights, including copyright in the text, images and layout of this booklet is owned by Focal Point Fires plc. You are not permitted to copy or adapt any of the content without the prior written permission of Focal Point Fires plc.

**All instructions must be handed to the user for safekeeping.**

**Revision D - 12/18**

© 2018 Focal Point Fires plc.

Section	Contents	Page No.	Section	Contents	Page No.
1.0	Important Notes	2	7.2	Installing the ceramics	6
2.0	Appliance Data	3	8.0	Testing and Commissioning	7
3.0	Installation Requirements	3	8.1	Checking the Burner & Spark Gap	7
3.1	Room Sizing	3	8.2	Operating the Appliance	8
4.0	Site Requirements	3	8.3	Operating Pressure	8
4.1	Ventilation	5	9.0	Briefing the customer	8
5.0	Unpacking the Appliance	5	10.0	Servicing	8
5.1	Component Checklist	5	10.1	Servicing the Burner Unit	9
6.0	Gas Supply Routes	5	10.2	Pilot Assembly	9
7.0	Fixing the Appliance	5	10.3	Catalysts	9
7.1	Removing/ Installing Castings	6	10.4	Testing for Firebox Leakage	9
			11.0	Troubleshooting Guide	10

## 1.0 IMPORTANT NOTES

- This appliance is a high efficiency, flueless catalytic flame effect gas fire. It provides radiant and convected warmth both efficiently and safely utilising the latest type of catalytic converter and burner technology.
- The appliance does not require a flue system of any type as the catalytic converter cleans the flue products to provide a complete combustion system, which is intrinsically safe. It is designed to operate on Natural Gas or LPG and is factory set for operation on the gas type, and at the pressure stated on the appliance data plate.
- The appliance incorporates a combustion monitoring system (Oxygen Depletion System). It must not be adjusted or put out of operation. If replaced then manufacturer's original parts must be used.
- This appliance must be installed by a GAS SAFE registered person to ensure that the size of the room in which the appliance is to be installed is sufficient and the ventilation provision for that room is sufficient for the appliance. Details of how to determine the suitable room size is given in section 3.1 of these instructions and details of how to determine suitable ventilation are given in section 4.1.
- In the event of gas leakage from the appliance, the gas supply must be turned off at the nearest isolating valve.
- The appliance must be installed in accordance with the following:
  - Manufacturers' Instructions.
  - The Building Regulations issued by the Department for Communities and Local Government, the Building Standards (Scotland) (Consolidation) Regulations issued by the Scottish Development Department.
  - Relevant British standards insofar as the relevant areas are not covered by these instructions.
  - For Republic of Ireland, reference should be made to the current edition of IS813 (the relevant standards governing installation).
- Failure to comply with the above could lead to prosecution and deem the manufacturer's warranty invalid.
- This appliance must be installed in accordance with the rules in force and used only in a sufficiently ventilated space. The appliance is designed to fit various types of situations as described in sections 3.0 and 4.0. The appliance must be installed in a correctly sized room (see section 3.1), and the correct purpose provided ventilation must be provided (see section 4.1).
- On no account should the appliance inlet or outlet openings be blocked or obstructed in any way (see figure 1). **Do not** place objects on top of the appliance.
- It should be noted that heaters create warm air currents. These currents move heat to wall surfaces next to the heater. Installing the heater next to vinyl or cloth wall coverings or operating the heater where impurities in the air (such as tobacco smoke, candle smoke etc.) exist, may cause the walls to become discoloured.
- This appliance is intended as a secondary source of heat only and should not be used in a room without some form of background heating present. If the appliance is used in a room as the sole source of heat, then condensation may occur on colder surfaces within the room.
- On first light up of a new appliance, burning off of high temperature paint and lubricants may occur for the first few hours of operation. During this period some smoke may be emitted from the outlet grille, this should be no cause for concern. Accordingly, the room should be well ventilated with all windows and doors open during this period. During this period the appliance may cause smoke alarms to sound. If this happens, reset the alarms, but do not remove the batteries.
- **WARNING:** Due to the nature of this product the area around the top of the appliance (i.e. the grille) gets very hot. Care should be taken when operating the appliance. The manufacturer of this appliance considers all surfaces as working surfaces with the exception of the control knob. The guard (glass front) is to prevent risk of fire or injury from burns and no part of it should be permanently removed. **It Does Not Give Full Protection For Young Children Or The Infirm.** Where young children, pets, the elderly or infirm are concerned, a suitable fireguard should be used.
- Consult ALL instructions before installation and use of this appliance. This appliance is free from any asbestos material.
- With the appliance installed in the minimum size room and with the ventilation specified the concentration of NO<sub>2</sub> in the room is less than 150ppb.

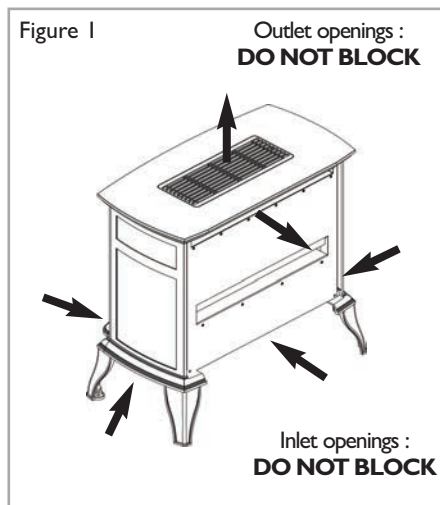

## 2.0 APPLIANCE DATA

GB IE

Destination Country	Gas Type	Cat	Inlet/Operating Pressure ( $\pm 2.0$ mbar)				Max Energy Input (kW)		Min Energy Input (kW)	
			G20	G25	G30	G31	Gross	Net	Gross	Net
GB - IE	Natural	I <sub>2</sub> H	20	-	-	-	3.1	2.8	1.5	1.35
	Propane	I <sub>3</sub> P I <sub>3</sub> +	-	-	-	37	3.1	2.8	1.5	1.35

Specifications	NG Models	LPG Models
Main burner injector	Stereo size I.30	Stereo size 83
Oxypilot	SIT 9110/ Copreci 21100 2F/ 296	SIT 9284
Gas Control	Teddington TESA 3173/011	Teddington TESA 3173/011
Gas Inlet	8mm restrictor elbow	8mm restrictor elbow
Ignition	Battery Spark	Battery Spark
Spark Gap	3.5 - 4.5mm	3.5 - 4.5mm

Please see Data Badge affixed to appliance for current data.

This appliance is for use only with the gas type, and at the pressure stated on the appliance Data Badge.

## 3.0 INSTALLATION REQUIREMENTS

If the appliance is to be sited near a disused or unserviceable fireplace served by a natural draught flue then the old flue must be sealed off. It will be necessary to ventilate the old flue to prevent condensation and dampness forming, however any air vent used to ventilate the old flue must not be sited within 1000mm of this appliance. If the flue can be ventilated to the outside of the building then this is usually the best solution. If in doubt then advice should be sought from a local building control officer. The appliance is designed to be floor mounted. If the appliance is to be mounted in front of a newly fabricated area of wall that also serves the purpose of sealing off the old flue then it is very important that there are no holes, gaps or otherwise in this wall that will allow draughts from the old flue to enter the room, especially directly behind the appliance. Such draughts could affect the performance of the ODS system and result in nuisance cutting out, for example. If the gas supply pipe is to enter the appliance from the rear, i.e. emerge from the wall behind the appliance, then any hole in the wall from which the pipe emerges must be tightly sealed. Propane/LPG models must not be installed in cellars, basements or any room which is completely below ground level.

### 3.1 ROOM SIZING

The room size **MUST** be a minimum of 35m<sup>3</sup> (e.g. 3.8m x 3.8m x 2.425m or 12'5" x 12'5" x 8').

This is to allow adequate circulation of air and ensure the correct operation of the fire. This volume may include adjacent spaces but these spaces must not be separated by a door. Note : To calculate a room size in cubic metres (m<sup>3</sup>) divide the room volume in cubic feet (ft<sup>3</sup>) by 35.3.

## 4.0 SITE REQUIREMENTS

This appliance may be installed in any room in the home except bathrooms. In accordance with BS5871 part 4, installation in bedrooms is permitted. If the appliance is to be installed in a bedroom then an electronic carbon monoxide detector complying with the current edition of BSEN 50291 must be installed in the same room as the appliance. For maximum safety it is recommended that such device is continuously (mains) powered and arranged in such a way that the gas supply to the appliance is isolated in the event of an alarm. The selection and installation of such device shall be in accordance with the current edition of BSEN 50292, and the user must be briefed regarding the use and maintenance of such a device.

The appliance is designed to be versatile, and as such will operate correctly when exposed to normal gentle draughts experienced within the home. It is not recommended, however that the appliance be installed in areas where it is likely to be directly exposed to persistent strong draughts, that may be generated by outside doors, windows, air vents, air conditioning units, extractor fans, ceiling fans etc. See section 4.1 for more information on ventilation.

#### Clearances to non-combustible materials

Non combustible surfaces are defined as brick, metal, natural stone, concrete etc. and also a number of man-made materials impervious to flame. If in doubt refer to the material manufacturer for further information before proceeding with installation.

Clearances to the sides of the appliance are 100mm (4"). Clearance to the front of the appliance is 500mm (20").

The back of the appliance may be installed directly in front of a non-combustible wall, providing the area behind the appliance is flat and does not interfere with the various vent holes in the back panel of the appliance.

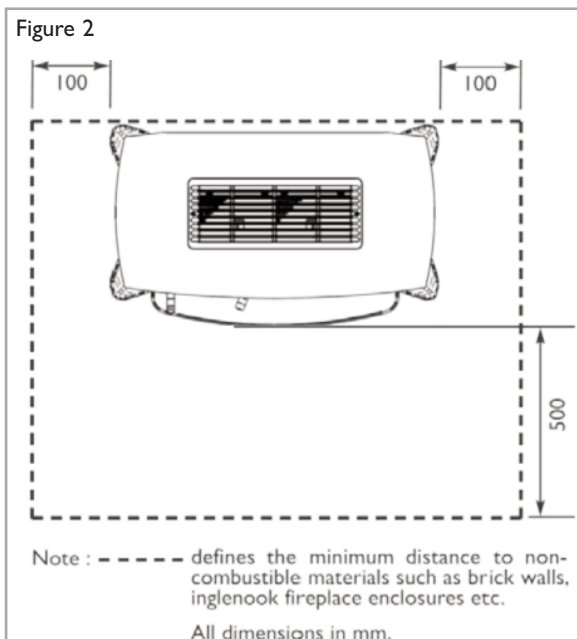

## 4.0 SITE REQUIREMENTS (CONTINUED)

GB IE

A non-combustible shelf of any depth may be positioned above the appliance provided it is no closer than 220mm (8.66") from the top of the appliance glass panel and the wall above the appliance is non combustible. The appliance can be mounted directly onto all types of combustible floors and hearths.

### Ingenooks & false chimney breasts

Where fitting in an ingenook or false chimney breast, the top, back and sides of the ingenook wall must be of a non combustible material such as calcium silicate, brick, or stone. Sizes and clearances must be in accordance with figure 2. If a void is created in a false chimney breast above the appliance it should be vented at high and low levels to allow air circulation (see figure 3). These vents should communicate with each other via the space inside of the false chimney breast in order to prevent heat build-up within the void and maximise the heat released into the room. Inside the ingenook, the minimum clearance from the top of the appliance is 220mm. Refer to figure 2 for clearance to the back, sides and front of the appliance.

Where an ingenook type installation is created below a disused flue then the flue should be properly de-commissioned and sealed at the base using non-combustible materials. The old flue should be ventilated to prevent condensation and possible damage to the fabric of the building. This ventilation cannot be used as purpose provided ventilation for the appliance and separate provision must be made for this (refer to section 4.1 for information on ventilation).

### Clearance to combustible materials

For other types of installations, it may be necessary to install the appliance in proximity to combustible materials. Combustible materials are generally defined as wood, fabrics, or other materials likely to combust if exposed to flame. Generally any material, which is likely to discolour, melt or misshape when exposed to moderate heat, should be considered as a combustible material or surface. If a combustible shelf or wooden fire surround are to be sited in proximity to the stove the following clearances (see figure 4) must be adhered to;

Maximum depth of shelf	Minimum distance from the top of the appliance to the underside of the shelf
50mm	220mm
75mm	280mm
150mm	450mm

### TV installation

Note; TV manufacturer's instructions must be consulted and take precedence insofar as positioning of heating appliances are concerned. If the stove is to be installed underneath a wall-mounted TV, then this can be achieved by installing a shelf above the appliance to protect the TV from the heat produced by the stove. The shelf must be constructed from a non-combustible material positioned 400mm from the top of the appliance. There must then be a clearance of 200mm from the top of the shelf to the bottom of the TV. The depth of the shelf depends on the depth (or protrusion from the wall) of the TV but must extend at least 50mm outward from the front of the TV. See figure 5. If a minimum distance of 50mm to the TV from the shelf front cannot be achieved it is acceptable to position the stove forward from the wall and use a deeper shelf. If this the case then the stove must be installed so as to prevent movement back to the wall. The non-combustible shelf must not project further forward than the back edge of the outlet grille on the top of the stove. In all cases the shelf must extend at least 50mm forwards from the TV.

### Clearance to other combustible materials

Clearance to the sides of the appliance are 100mm (4") but curtains, drapes and other fabrics are not permitted within a distance of 500mm (20") of the appliance side (see figure 6). No such materials are permitted directly above the appliance regardless of distance. The minimum clearance to the ceiling above the appliance is 800mm (31.5") measured from the top of the appliance. Combustible materials should not be positioned directly in front of the appliance within a distance of 1000mm.

It should be established that any mirrors or picture frames etc. to be positioned on the wall above the appliance are able to withstand prolonged exposure to moderate heat, before they are fitted above the appliance or the appliance is installed underneath them.

The back of the appliance may be installed directly in front of a combustible wall, providing it is flat and does not interfere with the various vent holes in the back panel of the appliance. The wall must be structurally sound and be constructed from a material capable of withstanding moderate heat. Brick, concrete, finished plaster, most types of conventional wall paper and dry-lined plasterboard are usually examples of suitable materials, however as there are many methods of wall construction and many variations in the composition of construction materials, in some circumstances, cracking may occur to plasterwork. Materials such as flock, blown vinyl and embossed paper which are sensitive to even small amounts of heat should be avoided as scorching and/or discolouration may occur over time. Avoid siting the appliance near joins or joints in plasterboard as exposure to moderate heat may cause cracking along the joint line. The appliance weighs 32kgs and it is important that the floor can support this weight. Take care that loose rugs are kept clear of the appliance as these can move against the appliance and become damaged.

Figure 3

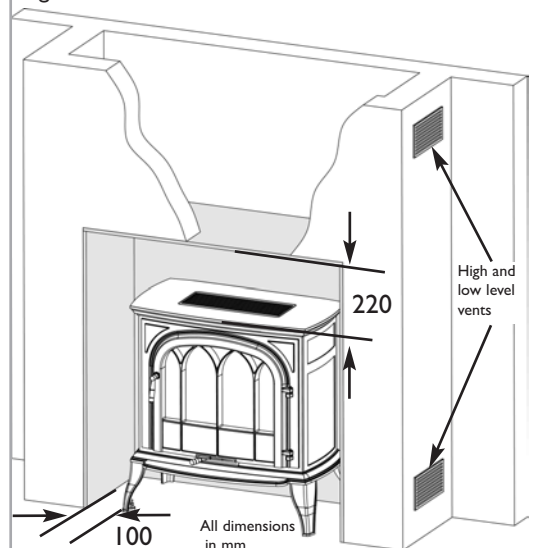
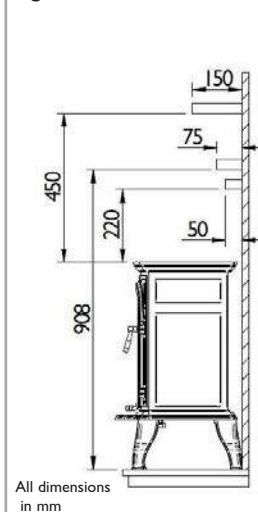
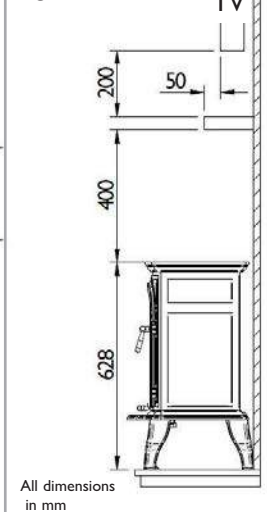

Figure 4



All dimensions in mm

Figure 5



All dimensions in mm

Figure 6

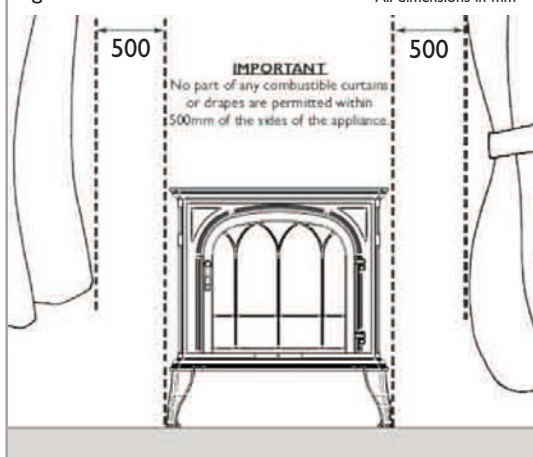

All dimensions in mm

If the room in which the appliance is installed is naturally ventilated, a minimum of 100 cm<sup>2</sup> purpose provided ventilation **MUST** be provided for this appliance. This may be achieved either with one vent 100 cm<sup>2</sup> at a high or low position in the room, or split ventilation i.e. 50 cm<sup>2</sup> to be installed at high level and 50 cm<sup>2</sup> to be installed at low level within the room. An openable window or equivalent is also required. To reduce the possibility of draughts, road noise or insects entering the room via the air vent, we recommend an air vent of the type that feature internal baffles. Ventilation fitted under, or within immediate vicinity of the appliance must not be used as it may adversely affect performance of the ODS system. The appliance shall not be installed within one metre of any existing air vent, and any new air vent shall not be installed within one metre of the appliance.

If the room in which the appliance is to be installed is served by heat recovery ventilation (HRV) or energy recovery ventilation (ERV) then no purpose provided ventilation is required but a room air change rate of at least one air change per hour is required for this appliance. The appliance **MUST** be interlocked with the ventilation system such that it is only possible to operate the appliance if the ventilation system is in operation. In all cases, the requirements of any other gas, oil or solid fuel appliances operating in the same room or space must be taken into consideration when assessing ventilation. All ventilation must communicate directly with outside air and must not pass through rooms or voids unless ducted. Any ventilation fitted must comply (where applicable) with BS 5871 part 4 and BS 5440 part 2. For Republic of Ireland refer to the current edition of IS813 and any relevant rules in force.

## 5.0 UNPACKING THE APPLIANCE

Remove the outer packaging, remove any instructions. Read **ALL** these instructions before continuing to unpack or install this appliance. Lift off the remaining packaging components and remove the contents of the box. Check that the components supplied correlate with the component checklist. Please dispose of all the packaging materials at your local recycling centre.

### 5.1 COMPONENT CHECKLIST

QUANTITY	DESCRIPTION
1	Stove assembly
1	Set of manufacturers instructions
1	Control handle
1	Control handle position marking sticker
1	Log set (1 x Front & 2 x Rear)
2	Levelling feet
1	Tiled ceramic set (2 x side panels & 1 x back)
2	No.8 x 5/16" screws
2	"L" brackets

## 6.0 GAS SUPPLY ROUTES

All installation pipework must be in accordance with the current edition of National regulations/codes and the rules in force.

In order to avoid unnecessary pressure drops, use of small diameter pipe should be kept to a minimum, for example, we recommend no more than 1.5 metres of 8mm pipe. If a concealed gas connection is to be made, the supply pipe should always be sleeved through walls and floors using the shortest possible route. For concealed supply pipe routing, pipes must (where possible) be vertical and providing there is sufficient wall thickness available, they should be placed in pipe chases. Horizontal pipe runs should be avoided. Prior to chasing a solid wall, an inspection should be made to note the proximity of any cables/sockets outlets which may be buried. Pipes must be secured using suitable clips and protected against corrosion. Ideally factory finished protected pipework and fittings should be used. Joints should be kept to a minimum and compression fittings must not be used. The pipework installation must be tested for tightness before any protection is applied and/or the pipework and fittings are buried.

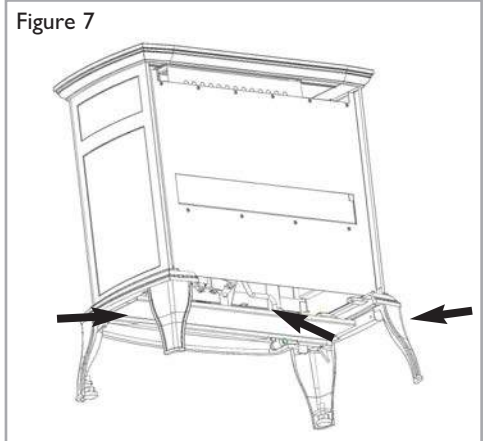

## 7.0 FIXING THE APPLIANCE

Position the stove in the proposed final location in accordance with sections 3.0, 3.1, 4.0, 4.1 and 6.0. If the hearth or floor surface is uneven, there are two adjustment feet that can be fitted behind the front two cast legs. Unscrew in a anti clockwise orientation to extend the feet and clockwise to contract the front legs. The horizontal alignment of the stove may be checked with a spirit level. Ensure that the stove sits on the adjustment feet not the legs as they prevent the fire from sliding on smooth surfaces.

## 7.1 REMOVING/INSTALLING THE CASTINGS

GB IE

Ensure that the fire is off and cool before attempting to remove or assemble castings.

The stove is supplied with the castings fitted. To fit the fuel bed it is necessary to partially dis-assemble the stove as follows;

- 1) Remove the top grille by the two screws in the top of the appliance, push the rear of the grille down so the front end of the grille lifts up. **DO NOT LEVER OFF WITH A SCREWDRIVER.**
- 2) Remove the top casting by unscrewing the four screws holding it in place.
- 3) Unscrew the cross head screw holding the front casting down at the top. The front casting is now free to be removed.
- 4) Remove the cover bracket and the glass door assembly by unscrewing the four retaining screws in each corner.
- 5) Fit the ceramic components as detailed in section 7.2.
- 6) Re-fit the cover bracket and the glass door assembly after cleaning or inspection, ensuring a good seal.
- 7) To re-assemble the castings read instructions in reverse order.
- 8) Attach the control handle into position through the opening in the front panel.

Figure 8

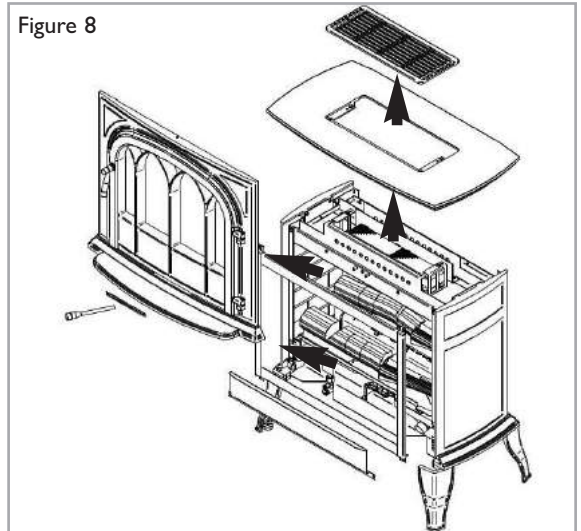

## 7.2 INSTALLING THE CERAMICS

Use a flat blade screw driver to carefully lever the two rear return tabs out to 90° on both left and right hand sides of the firebox as shown.

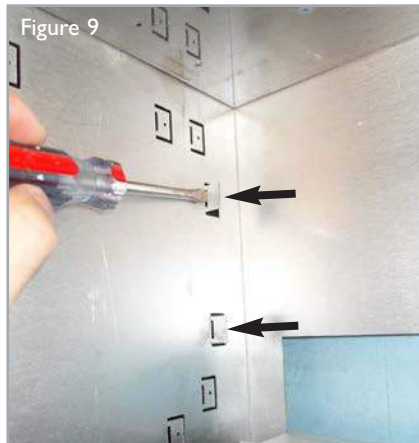

Figure 9

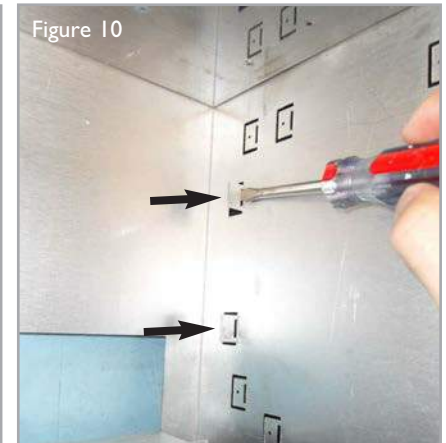

Figure 10

Next insert the rear brick panel through the bottom of the firebox as shown, in front of the returned tabs but behind the bottom lip. Ensure the brick effect is in the correct orientation, with the lip on the top edge.



Figure 11

Install one side brick panel in the left hand side of the firebox, behind the bottom return. Install the right hand brick panel in the same manner (the brick effect panels are not labelled). Ensure the brick effect is in the correct orientation, with the lip on the top edge, so the brick effect is continuous around the firebox.



Figure 12

Finally screw the “L” ceramic clamps into position in both side of the firebox with the self tapping screws provided.



1. Remove the ceramic components from their protective packaging. Place the log marked 'A' on the top left rear ledge behind the burner mixer chamber as shown in figure 14.



2. Place the log marked 'B' on the top right rear of the burner as shown in figure 15. Ensure that both rear logs are pushed back against the rear brick panel.



3. Place the log marked 'C' on the front ledge of the burner, behind the return and in front of the burner mixer chamber.



## 8.0 TESTING AND COMMISSIONING

Turn on and test the gas supply up to the fire for any leaks, in accordance with the current edition of BS 6891 (natural gas installations) or the current edition of BS 5482 pt1 (propane installations). For Republic of Ireland, reference should be made to the current edition of IS813 (the relevant standards governing installation).

### 8.1 CHECKING THE BURNER AND SPARK GAP

The appliance features a ribbon burner which is designed to produce a continuous band of flame over its length.

The burner should be visually inspected to ensure it is free from any foreign matter.

If it is necessary to clean or dust off the burner, ensure that the fire is off and cool. To remove see section 7.1. The gap between the spark electrode and the pilot should be 3.5 - 4.5mm to produce a good spark (see figure 17). There should be no need to adjust this. If under any circumstances the piezo electric spark fails, the pilot cannot be lit manually.

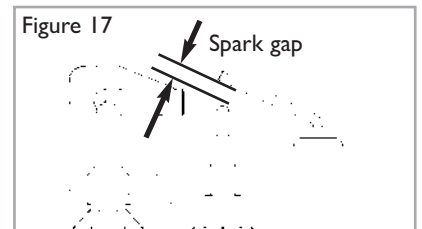

## 8.2 OPERATING THE APPLIANCE

GB IE

The control handle is located in the centre of the appliance. The control handle is marked as shown in figure 18.

The pilot is visible behind the centre of the burner.

Move the control handle fully right to the SPARK position, and hold there for approximately ten seconds. Now release the control handle and the pilot should stay alight. When the pilot light has established, move the control handle left to the LOW flame setting. If the pilot is extinguished during use, wait three minutes before repeating the ignition procedure. To achieve the HIGH setting, move the control handle left to the HIGH flame setting. The fire can also be set to operate anywhere between HIGH and LOW by moving the control handle to an intermediate position.

To turn the fire OFF, move the control handle left fully to the position marked 'O'.

Figure 18

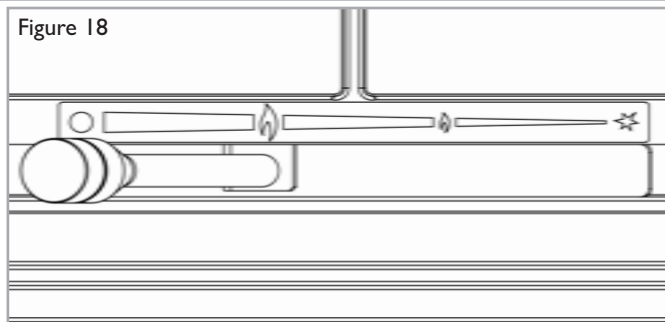

## 8.3 OPERATING PRESSURE

The pressure test point is located on the inlet restrictor elbow in the centre of the burner as shown in figure 19.

Release the pressure test point screw, and attach a pressure gauge. Light the fire on the HIGH setting. To commission the appliance, the operating pressure must be in accordance with the figures stated in section 2.0 of these instructions. The fire is factory set to achieve the correct flow rates at the specified inlet pressure.

Any significant variation in the operating pressure could indicate a supply problem. If the inlet pressure is too high, the gas supply meter/governor may be set incorrectly.

This should be checked with the fire running and if necessary reset by the gas supplier. If the operating pressure is too low, then check the meter/governor pressure with the appliance running. If this is less than the inlet pressure stated in section 2.0 of these instructions it will need to be reset by the gas supplier. If the inlet pressure is too low, but the meter/governor pressure is acceptable, then a problem in the supply pipework is to be suspected.

Upon satisfactory checking of the inlet pressure, turn the fire off, disconnect the pressure gauge and refit the test point screw. Light the fire and check for gas soundness. In the event that the inlet pressure is not in accordance with the figures stated in the data section of these instructions, the appliance must not be commissioned, and the problem investigated and rectified.

Figure 19

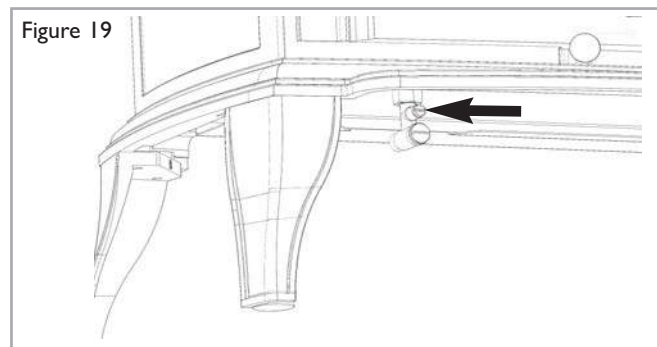

## 9.0 BRIEFING THE CUSTOMER

All instructions must be handed to the user for safekeeping. Show the customer how to light and control the fire.

After commissioning the appliance, the customer should be instructed on the safe use of the appliance and the need for regular servicing. Frequency of service depends on usage, but **MUST** be carried out at least once annually.

Advise that cleaning of the fire may be achieved when the fire is cold using a damp cloth and mild detergent on most surfaces. Advise that on first light up of a new appliance, initial curing of high temperature paint and burning off of lubricants may occur for the first few hours of operation. During this period some smoke may be emitted from the outlet grille, this should be no cause for concern. Accordingly, the room should be well ventilated with all windows and doors open during this period. During this period the appliance may cause smoke alarms to sound. If this happens, reset the alarms, but do not remove the batteries. Recommend that a guard be used for the protection of the young, pets, the elderly and the infirm. Advise the customer that the ventilation openings should not be blocked or obstructed in any way. **IMPORTANT**; Show the customer where the battery compartment is and how to change the battery.

## 10.0 SERVICING

Isolate the fire from the gas supply. Ensure that the fire is fully cold before attempting service.

A suggested procedure for servicing is detailed below.

1. Lay out the dustsheet and tools.
2. Remove the decorative casting assembly. See section 7.1.
3. Remove the cover bracket and the glass door assembly (4 screws) and clean carefully.
4. Inspect the burner, ceramics and the catalyst and clean if necessary with a soft brush.
5. Disconnect the gas supply.
6. Undo the two screws retaining the burner support brackets to the left and right hand side of the firebox.
7. Remove the burner unit, strip off the burner pipes and clean thoroughly.
8. Clean the injector, pilot assembly and the burner tube. Do not attempt to remove the pilot injector as this can cause damage.
9. Re-assemble components.
10. Turn on the gas supply and leak test. Check pilot and burner for good ignition.
11. Refit the cover bracket and the glass door assembly, ensuring correct orientation and a good seal.
12. Refit the decorative casting assembly. Installation is reverse of section 7.1.
13. Check the purpose provided ventilation is un-obstructed.
14. Light the fire and test the operating pressures.
15. Check safe operation of the appliance by performing a combustion test as detailed in section 10.3.

For specific servicing instructions, see relevant sections.



Firstly, remove the decorative casting assembly as described in section 7.1. Remove the control handle, and disconnect the gas connection inside appliance. The gas connections to the gas valve can now be released. Undo the two screws retaining the burner support brackets to the left and right hand side of the firebox. The burner may now be removed. Remove the pilot and main burner pipes and blow through to dislodge any debris. Now remove the restrictor elbow and blow through to make sure it is entirely clear.

Unclip the pilot lint gauze and clean with a soft brush. Clean the exterior of the pilot assembly with a soft brush and blow through the flame ports on the pilot head. Check the aeration holes are free from lint or dirt. The pilot assembly can be removed if required by disconnecting the electrode HT lead, gas pipe and unscrewing the mounting screws and lifting away.

The pilot assembly is a non-serviceable item and should not be taken apart. Aeration holes must be absolutely clear internally for proper operation.

**NEVER MODIFY OR BEND THE THERMOCOUPLE TO MAKE THE PILOT STAY ALIGHT.** Modifications are dangerous and can have serious unseen effects on safety. If the pilot will not stay lit there is a problem with dirt, the gas supply to it, or the thermocouple needs replacement.

The gas valve is a non-serviceable item. If this needs replacement, remove securing screws holding the valve in place, remove all pipe unions, electrode lead, thermocouple lead and then the complete valve. Replacement must be original manufacturers parts. Re-assembly is the reverse of removal. Ensure setting pressures are as stated in Section 2; Appliance Data.

## 10.2 PILOT ASSEMBLY

Remove the burner unit as detailed in section 8.1, then remove the lint arrestor and pilot unit by using a screwdriver to remove the retaining screws. Clean the pilot assembly with a soft brush and blow through. Check the aeration holes are free of any dirt or lint. Clean thoroughly. The connection can be removed from the base of the pilot unit using two spanners to make cleaning easier. Do not damage or try to dismantle the pilot injector. The unit is factory set and the only check necessary is to ensure the spark gap is correct. See specifications for gap setting in section 8.1.

**NEVER MODIFY OR BEND THE THERMOCOUPLE TO MAKE THE PILOT STAY ALIGHT.**

If the pilot will not stay lit there is a problem with dirt, the gas supply, or the thermocouple needs replacement. Modifications are dangerous and can have a serious unseen effect on safety and therefore **MUST** not be done. Replacements must be original manufacturers parts. Re-assembly is the reverse of removal. Ensure setting pressures are as stated in Section 2; Appliance Data.

## 10.3 CATALYSTS

It is recommended that the catalysts are inspected for signs of damage and dirt during routine servicing procedures. The expected life of the catalysts is in excess of 11,000 hours (10 years of normal use). After this time the catalysts should be replaced.

If there are any deposits of dirt or soot on the catalyst they should be cleaned with a soft brush and a vacuum cleaner. The performance of the catalysts may be checked using a combustion gas analyser as follows. Any analyser used should conform to EN 50379-3. Ignite the fire as per the operating instructions, and run at maximum setting for 15 minutes. Position gas sample probe directly over the catalysts via the outlet grille, on top of the appliance. Record the carbon dioxide (CO<sub>2</sub>) concentration and then the carbon monoxide (CO) concentration as displayed by the analyser - also noting the units in which the values are expressed. Most analysers display carbon dioxide (CO<sub>2</sub>) concentrations in percentage (%) terms and carbon monoxide concentration in parts per million (ppm) terms. The reading will be more accurate if the CO<sub>2</sub> is greater than 1%.

In order to calculate the combustion ratio for the appliance (CO/CO<sub>2</sub>) it is first necessary to express both gas concentrations in terms of percentage. To convert from parts per million (ppm) to a percentage (%) divide the ppm figure by 10,000. Examples : 35ppm = 0.0035%, 15ppm = 0.0015%, 5ppm = 0.0005%. Now divide the concentration of carbon monoxide (CO) expressed in percent by the concentration of carbon dioxide (CO<sub>2</sub>) to obtain the appliance combustion ratio.

$$\frac{\text{CO (\%)}}{\text{CO}_2 (\%)} = \text{ratio}$$

**The combustion ratio of the gasses emitted by the catalytic convertor should not exceed 0.0015.**

If replacing, firstly, remove the decorative castings (as described in section 7.1) and outer casing. The catalysts are located on the top of the internal firebox and can be removed by unscrewing the retaining nuts securing the clamping plates. Refit the new catalysts and seals in reverse order, ensure the catalysts and the glass door have good seals.

## 10.4 TESTING FOR FIREBOX LEAKAGE

Appliances that are several years old or have been extensively dismantled should be checked for soundness. It is important that all the products of combustion pass through the catalytic converter at the top of the firebox before leaving the appliance. The firebox is heated by lighting for a few minutes to provide a flow through the firebox. The burner is then shut off and a smoke pellet or match introduced at the base of the fire underneath the burner tray. Large quantities of smoke will emerge from the top of the appliance, but none should emerge from the joints or gasket faces, especially around the door. It is important to note that the appliance can never be expected to be 100% smoke tight and small quantities of smoke may be seen in corners of joints and gasket faces etc without affecting safety when the fire is in operation.

**Fire sparks but pilot does not light**

- No gas to fire, check isolators are open and gas supply is on.
- Pipework blockage, clean out.
- Air not fully purged, re purge supply or wait longer.
- Spark earthing to metalwork, reset gap correctly.
- Blocked pilot, clean out internally.

**Pilot lights but then goes out**

- Severe restriction in gas supply: clear obstruction.
  - Faulty thermocouple, replace pilot unit.
  - Blocked pilot, clean out.
  - Blocked lint gauze, clean.
  - Hold control handle in the spark position for longer.
  - Check control handle does not foul front casting.
  - If the pilot will not stay lit there could be a problem with contamination of the gas supply, drafts, room size and/or ventilation or the thermocouple needs replacement. Modifications are dangerous and can have a serious unseen effect on safety.
- NEVER MODIFY OR BEND THE THERMOCOUPLE TO MAKE THE PILOT STAY ALIGHT.**

**Fire does not spark at pilot**

- Replace battery. See section 10.0 of the user instructions.
- HT lead detached, refit.
- Check the spark gap (see section 8.1).
- Faulty piezo unit, replace.
- Debris shorting out electrode, clean.
- Spark shorting to metalwork under tray, check routing of HT lead under burner.

**Fire runs for a time and then cuts off**

- Loose or faulty thermocouple, rectify.
  - Blocked pilot, clean out.
  - Fire is sited in a draft.
  - Door or window has been opened creating a draft.
  - A wall which the fire is sited near has a hole/holes through which there is a draft
  - Fire is too close to an air vent.
  - Fire is sited on disused chimney breast which has not been adequately sealed up.
  - Dirt or lint in pilot aeration hole or on the lint gauze, clean thoroughly.
  - If the pilot will not stay lit there could be a problem with contamination of the gas supply, drafts, room size and/or ventilation or the thermocouple needs replacement. Modifications are dangerous and can have a serious unseen effect on safety.
- NEVER MODIFY OR BEND THE THERMOCOUPLE TO MAKE THE PILOT STAY ALIGHT.**

**Pilot flame shrinks when fire is on high**

- Poor gas flow to fire, check pressure with fire on high.
  - If pressure is low, remove any restriction in pipework or valve.
  - Check all isolators are adequately sized and fully open.
  - Check meter pressure is adequate.
  - If the pilot will not stay lit there could be a problem with contamination of the gas supply, drafts, room size and/or ventilation or the thermocouple needs replacement. Modifications are dangerous and can have a serious unseen effect on safety.
- NEVER MODIFY OR BEND THE THERMOCOUPLE TO MAKE THE PILOT STAY ALIGHT.**

**Fire smells when first lit or in use**

- Newness smell from brand new appliance.
- Leakage occurring. Carry out leakage check and rectify any problems.
- Combustible materials used in incorrect positions.
- Airborne substances such as cleaning materials/air fresheners are being drawn through the fire.
- Other airborne contaminants such as dust, tobacco smoke, paint vapours.

Section	Content	Page No
1.0	Important Notes	1
2.0	Siting & Clearances Around the Stove	2
3.0	Fire Guards	3
4.0	Ventilation & Room Size	3
5.0	Fuel Bed Layout	4
6.0	Operating the Appliance	4
7.0	Combustion Monitoring System	4
8.0	Servicing	4
9.0	Cleaning	5
10.0	Replacing the Battery	5
11.0	List of Replacement Parts	5
12.0	Installation Details	6
13.0	Service History	6
14.0	Appliance Dimensions	7
15.0	Guarantee - Terms and Conditions	7

## 1.0 IMPORTANT NOTES

• The installation and servicing of this fire **MUST** only be carried out by a correctly qualified GAS SAFE registered person.

Before you let your gas engineer into your home to work on your gas appliances make sure you check the front and back of their Gas Safe ID card. If they don't show this to you when they turn up at your door then don't be afraid to ask to see it. The card is there for your protection. Make sure that you check the front and back of the card. Check the front of the card for: the photo, the start date and expiry date, the licence number, the security hologram and that the engineer is from the business you employed.

Check the back of the card to make sure your engineer is qualified to do the gas work you want to be done, which in this case is "Fire" and "Pipework". Check their qualifications are up to date.

You can also check that your engineer is Gas Safe registered by calling Gas Safe Register on 0800 408 5500, using the check an engineer online at [www.gassaferegister.co.uk](http://www.gassaferegister.co.uk) or by texting Gas followed by the engineers licence number to 85080. Please note: Your provider may charge a standard network charge to use the text service.

If you suspect a gas fitter is illegal you can call Gas Safe Register on 0800 408 5500 and report them or use the online report an illegal gas fitted service.

• All work on this appliance must be in accordance with local Codes and/or Regulations, Building Regulations and the manufacturer's instructions. Failure to comply with the above could lead to prosecution and invalidate the appliances warranty. In the event of a gas leakage from the appliance, the gas supply must be turned off at the nearest isolating valve. This appliance is only suitable for the gas type for which it is supplied.

• Keep a note of the installer's name and address, Gas Safe Registration number and the original purchase receipt and the date of installation. Failure to produce this information may invalidate the warranty. The appliance should be serviced regularly to ensure continued safe operation. See servicing section for further reference.

• The guard (glass front) is to prevent the risk of fire or injury from burns and no part of it should be permanently removed. **It Does Not Give Full Protection For Young Children Or The Infirm.** Parts of this appliance become naturally hot during use. It is recommended that a suitable fireguard is used, especially where young children, pets, the elderly or infirm are concerned. The manufacturer of this appliance considers all surfaces as working surfaces with the exception of the control knob and immediate area behind.

• Combustible items, such as flooring and furniture or soft wall coverings (such as blown vinyl or embossed paper), low temperature surrounds etc may discolour if fitted too close to the fire. See relevant section for further details on clearances to combustibles. No combustible materials or flooring should protrude onto the hearth (if fitted).

• This appliance incorporates a combustion monitoring system (ODS)

• **DO NOT** burn any foreign material on this fire. Under no circumstances shall the appliance be used if the glass front door or panel has been removed, damaged or is open. On no account should the appliance inlet or outlet openings be blocked or obstructed in any way (see figure 1). **DO NOT** place objects on top of the appliance.

• **WARNING:** Due to the nature of this product the area around the top of the appliance (i.e. the grille) gets very hot. Care should be taken when operating the appliance.

The integral catalysts should be checked by the installer upon servicing to ensure there are no defects or obstructions that may prevent the satisfactory flow of combustion products. The expected life of the catalyst is in excess of 11,000 hours (10 years of normal use). After this time the catalyst should be replaced.

• Should any home improvements be carried out to the property after the fire is installed, such as installation of extractor fans for example, the fire should be re-checked by a competent person for safe operation.

• This appliance may be installed in any room in the home except bathrooms. In accordance with BS5871 part 4, installation in bedrooms is permitted. If the appliance is to be installed in a bedroom then an electric carbon monoxide detector complying with the current edition of BSEN 50291 must be installed in the same room as the appliance. For maximum safety it is recommended that such device is continuously (mains) powered and arranged in such a way that the gas supply to the appliance is isolated in the event of an alarm. The selection and installation of such device shall be in accordance with the current edition of BSEN 50292, and the user must be briefed regarding the use and maintenance of such device.

Figure 1

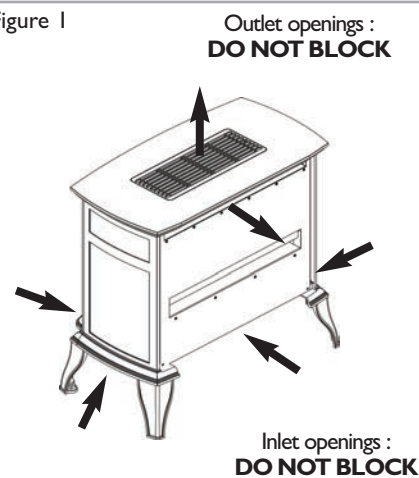

The appliance is designed to be versatile, and as such will operate correctly when exposed to normal gentle draughts experienced within the home. It is not recommended, however that the appliance be installed in areas where it is likely to be directly exposed to persistent strong draughts, that may be generated by outside doors, windows, air vents, air conditioning units, extractor fans, ceiling fans, etc. See section 4.0 for more information on ventilation.

### Clearances to non-combustibles

Non combustible surfaces are defined as brick, metal, natural stone, concrete etc. and also a number of man-made materials impervious to flame. If in doubt refer to the material manufacturer for further information before proceeding with installation.

Clearances to the sides of the appliance are 100mm (4"). Clearance to the front of the appliance is 500mm (20"). See figure 2.

The back of the appliance may be installed directly in front of a non-combustible wall, providing the area behind the appliance is flat and does not interfere with the various vent holes in the back panel of the appliance.

A non combustible shelf of any depth may be positioned above the appliance provided it is no closer than 220mm (8.66") from the top of the appliance and the wall above the appliance is non combustible. The appliance can be mounted directly onto all types of non-combustible floors and hearths.

### Inglenooks & false chimney breasts

Where fitting in an inglenook or false chimney breast, the top, back and sides of the inglenook wall must be of a non combustible material such as calcium silicate, brick, or stone. Sizes and clearances must be in accordance with figure 2. If a void is created in a false chimney breast above the appliance it should be vented at high and low levels to allow air circulation. These vents should communicate with each other via the space inside of the false chimney breast in order to prevent heat build-up within the void and maximise the heat released into the room. Inside the inglenook, the minimum clearance from the top of the appliance is 220mm. Refer to figure 2 for clearance to the back, sides and front of the appliance.

Where an inglenook type installation is created below a disused flue then the flue should be properly de-commissioned and sealed at the base using non-combustible materials. The old flue should be ventilated to prevent condensation and possible damage to the fabric of the building. This ventilation cannot be used as purpose provided ventilation for the appliance and separate provision must be made for this (refer to section 4.0 for information on ventilation).

### Clearance to combustible materials

For other types of installations, it may be necessary to install the appliance in proximity to combustible materials. Combustible materials are generally defined as wood, fabrics, or other materials likely to combust if exposed to flame. Generally any material, which is likely to discolour, melt or misshape when exposed to moderate heat, should be considered as a combustible material or surface. If a combustible shelf or wooden fire surround are to be sited in proximity to the stove the following clearances (see figure 5) must be adhered to;

Maximum depth of shelf	Minimum distance from the top of the appliance to the underside of the shelf
50mm	220mm
75mm	280mm
150mm	450mm

### TV installation

Note; TV manufacturer's instructions must be consulted and take precedence insofar as positioning of heating appliances are concerned. If the stove is to be installed underneath a wall-mounted TV, then this can be achieved by installing a shelf above the appliance to protect the TV from the heat produced by the stove.

The shelf must be constructed from a non-combustible material positioned 400mm from the top of the appliance. There must then be a clearance of 200mm from the top of the shelf to the bottom of the TV. The depth of the shelf depends on the depth (or protrusion from the wall) of the TV but must extend at least 50mm outward from the front of the TV. See figure 4. If a minimum distance of 50mm to the TV from the shelf front cannot be achieved it is acceptable to position the stove forward from the wall and use a deeper shelf. If this the case then the stove must be installed so as to prevent movement back to the wall. The non-combustible shelf must not project further forward than the back edge of the outlet grille on the top of the stove. In all cases the shelf must extend at least 50mm forwards from the TV.

Figure 2

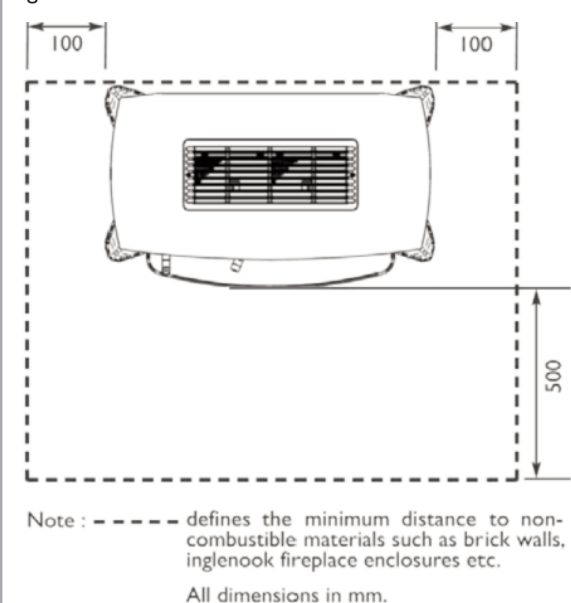

Figure 3

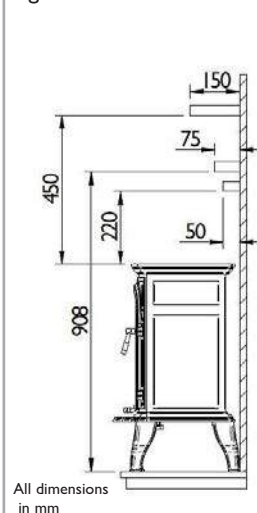
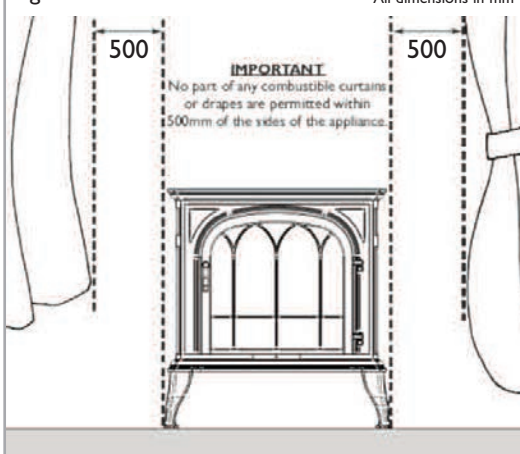

Figure 4



Figure 5



**Clearances to combustible materials (continued)**

Clearance to the sides of the appliance are 100mm (4") but curtains, drapes and other fabrics are not permitted within a distance of 500mm (20") of the appliance side (see figure 6). No such materials are permitted directly above the appliance regardless of distance. The minimum clearance to the ceiling above the appliance is 800mm (31.5") measured from the top of the appliance. Combustible materials should not be positioned directly in front of the appliance within a distance of 1000mm.

It should be established that any mirrors or picture frames etc. to be positioned on the wall above the appliance are able to withstand prolonged exposure to moderate heat, before they are fitted above the appliance or the appliance is installed underneath them.

The back of the appliance may be installed directly in front of a combustible wall, providing it is flat and does not interfere with the various vent holes in the back panel of the appliance. The wall must be structurally sound and be constructed from a material capable of withstanding moderate heat. Brick, concrete, finished plaster, most types of conventional wall paper and dry-lined plasterboard are usually examples of suitable materials, however as there are many methods of wall construction and many variations in the composition of construction materials, in some circumstances, cracking may occur to plasterwork. Materials such as flock, blown vinyl and embossed paper which are sensitive to even small amounts of heat should be avoided as scorching and or discolouration may occur over time. Avoid siting the appliance near joints or joints in plasterboard as exposure to moderate heat may cause cracking along the joint line. The appliance weighs 32kgs and it is important that the floor can support this weight. Take care that loose rugs are kept clear of the appliance as these can move against the appliance and become damaged.

Take care that loose rugs are kept clear of the appliance as these can move against the appliance and become damaged.

**3.0 FIRE GUARDS**

The fireguards specified in BS 8423 are intended to protect people from falling into a fire, prevent burns and reduce the risk of injury, particularly to young children and the infirm. In addition it is intended to reduce the risk of fire resulting from clothing and/or other flammable materials coming into contact with, or in proximity to, burning fuel and/or hot surfaces.

Fireguards can be permanently fixed in position or can be moveable, and can be used with open fires including combination grates, or closed fires, including room heaters and stoves. **See figures 6 & 7 for fireguard examples.**

The fireguards specified are not intended to reduce the risk of fires caused by flying particles, which are covered by BS 3248.

**Figure 6**

Example of moveable fireguard for portable heating appliances

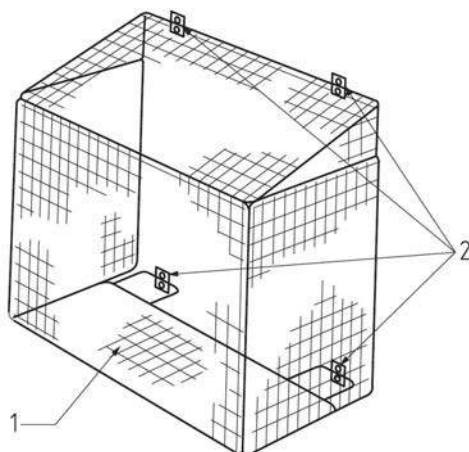
**Key**

1. Optional base section for total enclosure of a wall mounted appliance
2. Points for attachment to a wall.

**Figure 7**

Example of detachable fireguard

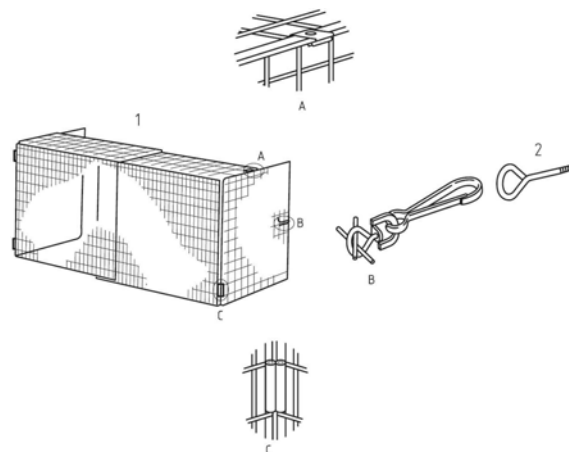
**Key**

1. Detachable fireguard
2. Screw eye

**4.0 VENTILATION & ROOM SIZE**

Purpose provided ventilation of 100cm<sup>2</sup> **MUST** be provided for this appliance. An openable window or equivalent is also required. Any ventilation fitted must comply with local Codes and/or Regulations. Ventilation fitted under, or within immediate vicinity of the appliance must not be used as it may adversely affect performance of the combustion monitoring system (ODS) system. The appliance shall not be installed within one metre of any existing air vent, and any new air vent shall not be installed within one metre of the appliance.

**WARNING :Ventilation openings must never be blocked or restricted in any way.**

The requirements of other appliances operating in the space or room must be taken into consideration when assessing ventilation requirements, this should have been carried out by your installer. A supply of fresh air into the room is advisable to maintain temperatures within limits.

The room size **MUST** be a minimum of 35m<sup>3</sup> (e.g. 3.8m x 3.8m x 2.425m or 12'5" x 12'5" x 8'). This is to allow adequate circulation of air and ensure the correct operation of the fire. This volume may include adjacent spaces but these spaces must not be separated by a door.

**Note :** To calculate a room size in cubic metres (m<sup>3</sup>) divide the room volume in cubic feet (ft<sup>3</sup>) by 35.3.

It should be noted that heaters create warm air currents. These currents move heat to wall surfaces next to the heater. Installing the heater next to vinyl or cloth wall coverings or operating the heater where impurities in the air (such as tobacco smoke, candle smoke etc.) exist, may cause the walls to become discoloured. This appliance is intended as a secondary source of heat only and should not be used in a room without some form of background heating present. If the appliance is used in a room as the sole source of heat, then condensation may occur on colder surfaces within the room. This appliance must not be used in bathrooms. Refer to section 4.0 of the installation instructions for guidance on installations in bedrooms.

**Ensure that the fire is off and cool before attempting to remove or assemble casting.**

The stove is supplied with the casting fitted. To access the fuel bed it is necessary to partially dis-assemble the stove. (see figure 8). A no.2 pozi drive screwdriver will be required for this. The procedure is as follows;

- 1) Remove the top grille by the two screws in the top of the appliance and push the rear of the grille down so the opposite end of the grille lifts up. **DO NOT LEVER OFF.**
- 2) Remove the top casting by unscrewing the four screws holding it in place.
- 3) Unscrew the cross head screw holding the front casting down at the top.
- 4) Unscrewing the control handle in a anti clockwise orientation. The front casting is now free to be removed.
- 5) Remove the cover bracket and the glass door assembly by unscrewing the four retaining screws in each corner.
- 6) The fuel bed ceramic components may now be removed for cleaning (see section 9.0 for further details).
- 7) To replace the ceramic logs, first place the log marked 'A' on the top left rear ledge behind the burner as shown in figure 9.
- 8) Place the log marked 'B' on the right rear of the burner as shown in figure 10.
- 9) Place the log marked 'C' on the front ledge of the burner, behind the return and in front of the gas burner as shown in figure 11.
- 10) Clean glass panel if required (see section 9.0)
- 11) Re-fit the cover bracket and the glass door after cleaning or inspection, ensuring a good seal.
- 12) To re-assemble the castings read instructions in reverse order.

Figure 8

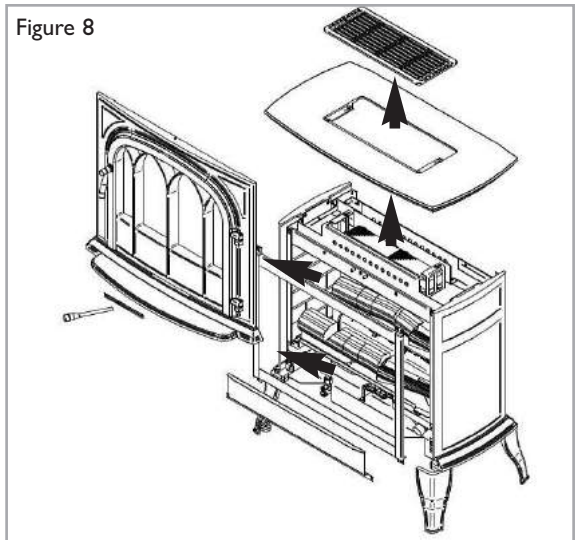

Figure 9



Figure 10



Figure 11



## 6.0 OPERATING THE APPLIANCE

The control handle is located in the centre of the appliance. The control handle is marked as shown in figure 12.

The pilot is visible behind the centre of the burner.

Move the control handle fully right to the SPARK position, and hold there for approximately ten seconds. Now release the control handle and the pilot should stay alight. When the pilot light has established, move the control handle left to the LOW flame setting. If the pilot is extinguished during use, wait three minutes before repeating the ignition procedure.

To achieve the HIGH setting, move the control handle left to the HIGH flame setting. The fire can also be set to operate anywhere between HIGH and LOW by moving the control handle to an intermediate position.

To turn the fire OFF, move the control handle left fully to the position marked 'O'.

Figure 12

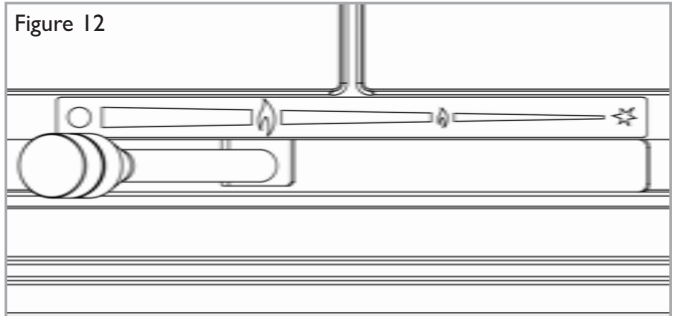

## 7.0 COMBUSTION MONITORING SYSTEM

This fire is fitted with a combustion monitoring safety device (ODS). If the appliance shuts down during use for no apparent reason then several reasons may be suspected. If a door or window has been opened creating a draught, then pilot disturbance could be the problem and removal of the draught should resolve this. The appliance can then be re-lit in accordance with the previous section. If pilot disturbance is not the cause, then the ODS safety system may be in operation. Switch the appliance OFF, call in your installer to check the appliance and ventilation. Remedial work must be carried out as required. **DO NOT** allow the appliance to be used until the appliance and installation is passed as safe. If the pilot continues to be extinguished, you must call your installer to check the operation of the complete appliance.

## 8.0 SERVICING

The appliance should be checked on an annual basis to ensure it is working safely and that there is no excessive build up of soot. The frequency of service will depend on usage, but **MUST** be carried out at least once annually. Servicing must be carried out by a competent person, such as a GAS SAFE registered installer.

## 9.0 CLEANING

GB IE

Before carrying out any of the following operations, ensure that the appliance is OFF and completely cold. Regularly clean around the appliance to ensure that dust, fluff, pet hair etc, are kept to a minimum. There are no other specific requirements for care, other than regular cleaning of the general appliance.

A wipe with a dry cloth is normally sufficient. **DO NOT** use abrasive cleaners as they can damage the finish. Metal parts may be cleaned using an appropriate metal cleaner. Test on a hidden part before cleaning. Clean only in the direction of the grain.

GLASS PANEL - This can be cleaned with a suitable glass cleaner. Test on a small area first.

PAINTED AREAS - These can be cleaned using a dry cloth.

CERAMICS - Remove the ceramic components. Gently clean in the open air. Be careful not to create dust from the logs. Where necessary replace damaged components with genuine spares. Seal scrap components in plastic bags and dispose of at proper refuse sites as directed.

## 10.0 REPLACING THE BATTERY

**Ensure appliance is off and cool.** The battery is located in the front of the ignition unit, on the right hand side of the burner (Shown in figure 13). Unscrew the battery holder cap. Insert 1 x 'AA' (1.5 volt) battery. Replace cap. This can be achieved without removing the castings.

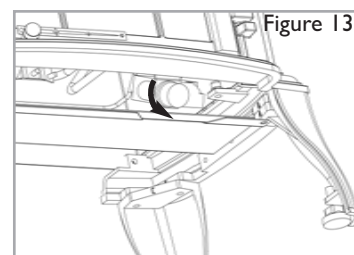

Figure 13

## 11.0 LIST OF REPLACEMENT PARTS

The Installation instructions carry full servicing details for the use of the installer.

PART NO.	ITEM
F550436	Ceramic log set
F550433	Ceramic brick tiles
F550435	Glass tiles
F550339	Glass door assembly
F730067	Gas valve
F730069	Pilot assembly - (Natural Gas SIT 9110)
F730106	Pilot assembly - (Natural Gas Copreci 21100 2F/ 296)
F730045	Pilot assembly - (LPG - Propane)
F730070	Injector - (Natural Gas 1.30)
F730113	Injector - (LPG - Propane .83)
F510127	Burner unit (Natural Gas)
F510133	Burner unit (LPG - Propane)
F780079	Catalyst
F740004	Ignitor





Figure 14

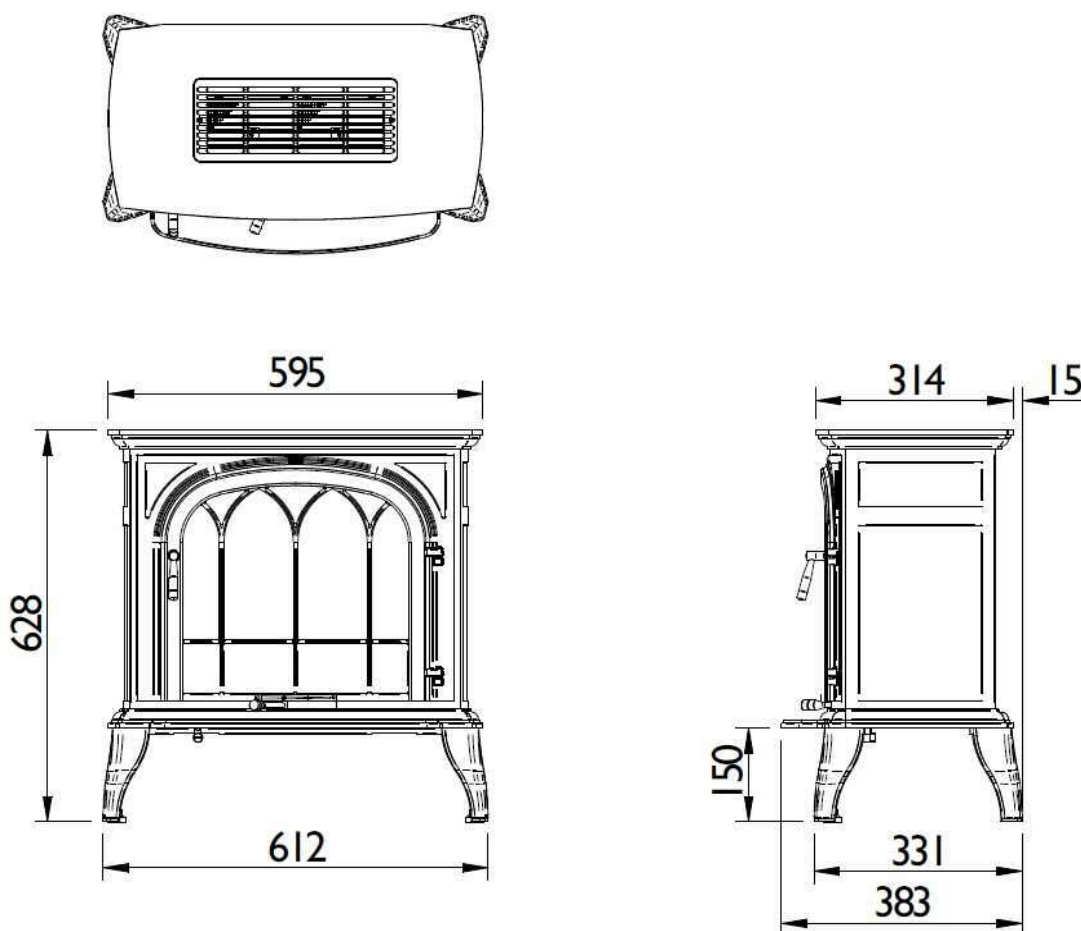

All dimensions in mm

# 15.0 GUARANTEE - TERMS AND CONDITIONS

Registration is not required.

Appliances purchased prior to 1st February 2009, and those specifically marked as '1 year guarantee' on this website, are guaranteed for one year from the date of purchase, provided that the following three terms and conditions are adhered to:

1. For any claim to be made within 1 year from date of purchase you will be required to provide and supply us with your original proof of purchase.
2. Your gas fire must have been commissioned by Gas Safe registered installer, evidence of which you must provide together with the registration number.
3. All appliances must have been installed and operated in accordance with the manufacturer's instructions.

3 Year Guarantee Terms and Conditions

Please be advised that the 3 year guarantee only covers products purchased on or after 1st February 2009.

The 3 year guarantee is only applicable to purchases made through an authorised stockist/retailer. Please see our website for a list of authorised stockists. Any purchase(s) made through an unauthorised stockist(s) will be eligible for a statutory 1 year guarantee.

For all gas fires purchased the 3 year guarantee commences from the date of purchase, provided that the following 4 terms and conditions are adhered to:

1. For any claim to be made within the 3 years from date of purchase you will be required to provide and supply us with your original proof of purchase.
2. Your gas fire must have been commissioned by Gas Safe registered installer, evidence of which you must provide together with the registration number.
3. Your appliance must have been serviced annually by Gas Safe registered installer, evidence of which must be provided, such as the receipt.
4. Purchase(s) must be made through an authorised stockist/retailer.

Please note all consumable items such as any ceramics including; coals, pebbles, the matrix, front strips, side cheeks, rear panels and tapered rear panels are not covered by the 3 year guarantee.

During the guarantee period any product or component which is proved to be faulty or defective in manufacture, will be repaired or replaced free of material and labour charges, providing that we have authorised or carried out the repair or replacement.

We will not accept or reimburse the costs of any third party who undertakes any work carried on the product or fits parts, unless we have approved such work in advance of it being carried out.

The guarantee period will not be extended even if we repair or replace any product or part.

For all electric fires purchased the 3 year guarantee commences from the date of purchase, providing that you can supply the proof of purchase. This does not cover consumable items such as pebbles, coals or light bulbs. Purchase(s) must be made through an authorised stockist.

Making a claim:

Making a claim is easy. If you wish to make a claim under our guarantee and all the terms and conditions for your product have been met then please email [sales@ekofires.co.uk](mailto:sales@ekofires.co.uk). Alternatively, you can write to: Eko Fires, Service Department, Reid Street, Christchurch, Dorset, BH23 2BT or fax: 01202 588639.

Details required:

1. Name, full address including postal code and contact telephone number.
2. A copy of your proof of purchase e.g. receipt or bank statement.
3. Original installers Gas Safe registration number (gas fires only).
4. Annual service receipt for every 12 months (gas fires only).

Please note that this does not affect your statutory rights.