

THE HOTTEST NAME IN HEATING

FIRECHARM R.S. Electronic

Room Sealed Live Fuel Effect Gas Fire

G.C. No. 32 689 43 (BLACK)

G.C. No. 32 689 44 (BRONZE)

Installation and Servicing Instructions

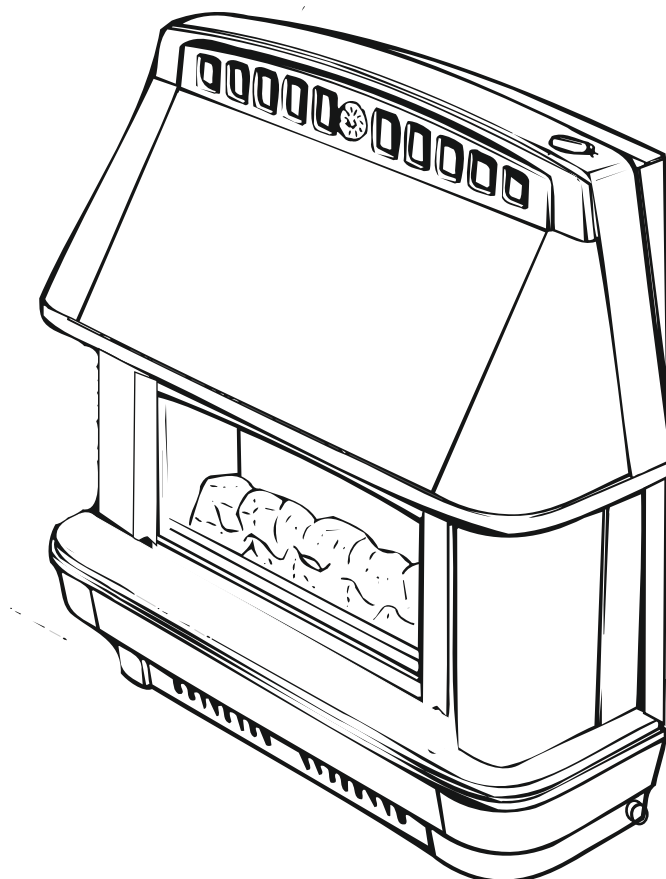

**'CE MARKED' FOR USE IN G.B. & I.E.
LEAVE THESE INSTRUCTIONS WITH THE USER**

DESCRIPTION

The FIRECHARM R.S. Electronic is a room sealed, live fuel effect gas fire with coals. The outer case is available in antique bronze or black finish. The fire can be wall or hearth mounted on a non-combustible wall or hearth, and can be fitted into a suitable fire surround. It can be installed from the inside of a building making it ideal for rooms where access from the outside is difficult, for example multi-storey buildings. A combustible wall kit, No. 994530 is available as an optional extra.

Three telescopic flues are available;

Short flue for walls from 75mm to 203mm No. 993241

Medium flue for walls from 200mm to 356mm No. 993240

Long flue for walls from 356mm to 510mm No. 993239

NOTE: The fire is supplied with the Medium flue (200mm to 356mm) Only. The others are all optional extras.

The fire is for use on Natural Gas only (G20 at 20mbar supply pressure). The appliance data badge is positioned on the left hand side of the backplate.

This product uses fuel effect pieces containing Refractory Ceramic Fibre (RCF), which are man-made vitreous silicate fibres. Excessive exposure to these materials may cause temporary irritation to eyes, skin and respiratory tract, consequently, it makes sense to take care when handling these articles to ensure that the release of dust is kept to a minimum.

To ensure that the release of fibres from these RCF articles is kept to a minimum, during installation and servicing we recommend cleaning should be carried out in a well-ventilated area or in the open air, by gently brushing with the pieces held away from your face so that you avoid inhaling the dust. We do not recommend the use of a normal domestic vacuum cleaner, which may blow dust back into the air. *If a vacuum cleaner is recommended for use by your organisation, you must use a HEPA filtered vacuum to remove any dust and soot accumulated in and around the fire before and after working on the fire.* When replacing these articles we recommend that the replaced items are not broken up, but are sealed within heavy duty polythene bags, clearly labeled as RCF waste. This is not classified as "hazardous waste" and may be disposed of at a tipping site licensed for the disposal of industrial waste. Protective clothing is not required when handling the articles, but we recommend you follow the normal hygiene rules of not smoking, eating or drinking in the work area and always wash your hands before eating or drinking.

TECHNICAL REQUIREMENTS

Gas Safety (Installation and Use) Regulations. It is the law that all gas appliances are installed by competent persons, i.e. Gas Safe registered Engineer, in accordance with these installation instructions, all the relevant parts of the local and national Building Regulations and all recommendations of the following British Standard Codes of Practice:

The following items relate to this appliance:

1. BS 5871 : Part 1
2. BS 5440 : Part 1 (Flues)
3. BS 6891
4. The Building Regulations issued by the Department of Environment and the Building Standards (Scotland) (Consolidation) Regulations issued by the Scottish Development Department.
5. Any other relevant British Standard Code of Practice and/or Local Building Regulations.
6. These installation instructions and in accordance with the rules in force.

NOTE: Purpose built ventilation is not normally necessary in G.B.. In I.E., the installation must be in accordance with IS 813.

1.0 TECHNICAL DATA

The efficiency of this appliance has been measured as specified in BS EN 613:2001 and the result is 79.3%. The gross calorific value of the fuel has been used for this efficiency calculation. The test data from which it has been calculated has been certified by Notified Body No.0087. The efficiency value may be used in the UK Government's Standard Assessment Procedure (SAP) for energy rating of dwellings.

The above exceeds the minimum requirement of 58%.

DIMENSIONS

Height 633mm Width 646mm Depth 272.5mm

Weight 20Kg

Max. Heat Input 4.5kW (gross) Min. Heat Input 1.5kW (gross)

Max. Heat Output 3.57kW Min. Heat Output 1.0kW

Height to Centre Line of Flue 351mm

Supply Pressure 20.0mbar (8in w.g.)

Setting Pressure (Cold) 17.5mbar ± 1mbar (7in w.g. ± 0.4in w.g.)

Burners Main Aerated Duplex

Injectors Upper Cat 77/180 Lower Cat 77/160

Pilot SIT 0150060

Pilot SIT No. 34

Ignition Battery spark generator

Flame Control RW Pt No. 987623

Spark Gap 3 to 4 mm

Control Knob Settings OFF, $\overline{\text{P}}$ PILOT, 1, HIGH, 2, ECON.

2.0 UNPACKING

The fire is packed in a carton together with the following items (See Fig. 1):-

1. Medium flue assembly and sealing tape (two pieces).
2. Gasket pack comprising flue and air duct gaskets and sealing gasket.
3. Flue sealing plate.
4. Pack of fittings comprising:

4 Wall fixing screws (2in wood)	810500
4 Wall plugs	820813
3 M4 x 10 Taptite screws (air duct)	810327
2 No. 6 S/T x 10 posi pan	810776
5. Foam seal pack. 822092.
6. A template representing the backplate full size; indicating the positions of the air inlet duct and fixing screw positions.
7. The fuel effect.

Remove the items and keep in a safe place. Lay the fire on its back in a safe place.

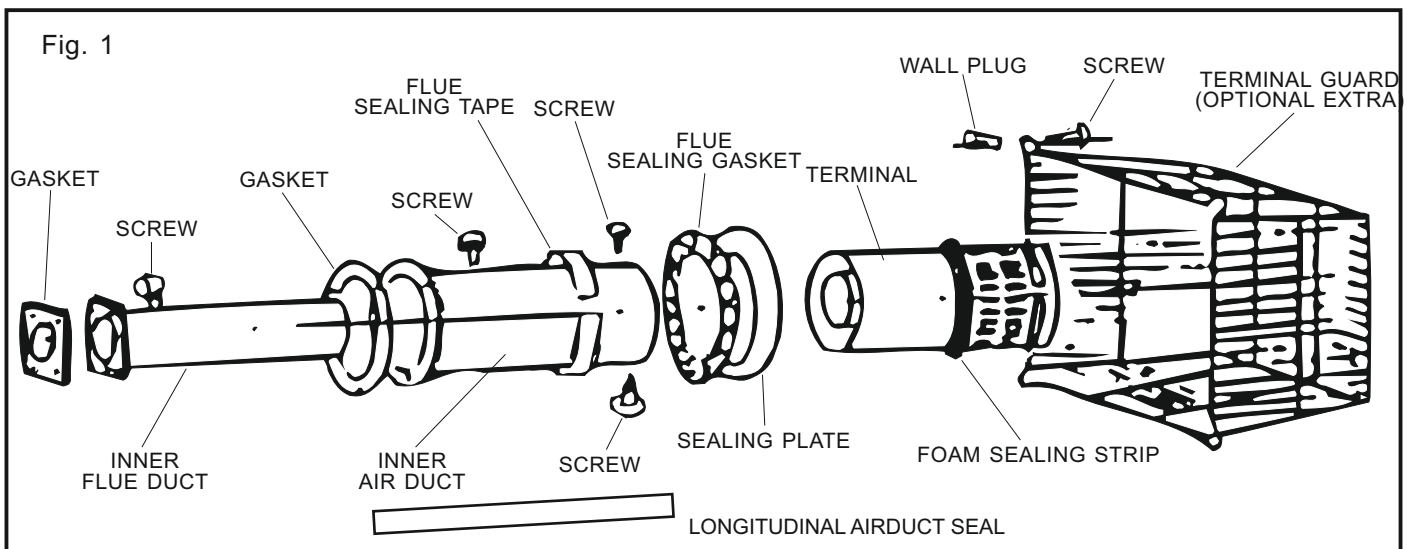

3.0 SITING GENERAL

The fire must be mounted on the inner face of a suitable external wall of thickness 75mm minimum and 508mm maximum.

- (a) **HEARTH MOUNTING:** If the fire is to be hearth mounted, the hearth must be of non-combustible material at least 13mm thick and measuring at least 670mm wide by 300mm deep with the fire central. Its top surface should preferably be 50mm above the floor level to discourage placing of rugs or carpets over it.
- (b) **WALL MOUNTING:** The fire may be fitted on a non-combustible wall such that the bottom of the backplate of the fire is at least 60mm above the finished floor level.
 NOTE: Soft wall coverings e.g. blown vinyl wallpaper may become discoloured if close to a heating appliance. Please bear this in mind when installing this fire and when redecorating.
- (c) **FITTING IN A FIRE SURROUND (Fig. 2):** The fire can be fitted in a compatible fire surround having a standard gas fire cut-out or with a hole 135mm diameter to accept the flue. The material of the surround must be suitable for 100 degC application i.e. marked with the suffix '100'.
 The inside of the external wall should be sealed off to prevent draught from the cavity into the room. A foam seal pack is provided for this purpose. Wrap some of the foam seal around the inner air duct so that when the fire is installed, the foam seal expands to prevent draught into the room.

NOTES;

1. The foam seal starts to expand once the compression tape is removed. Hence the foam seal should be put on only when the fire is ready to be installed.
2. When fixing the flue length, the wall thickness must be measured from the inner face of the fire surround (Refer to Section 5.2).

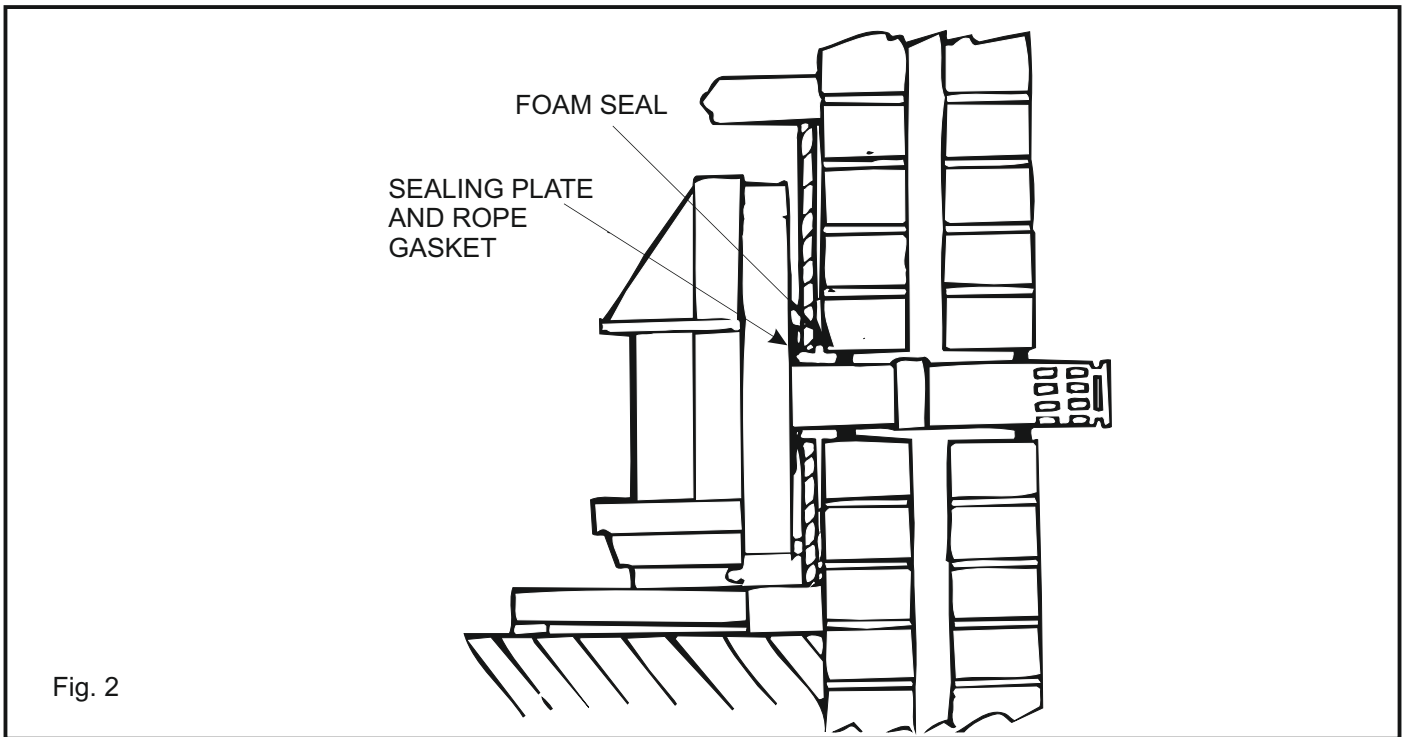

Fig. 2

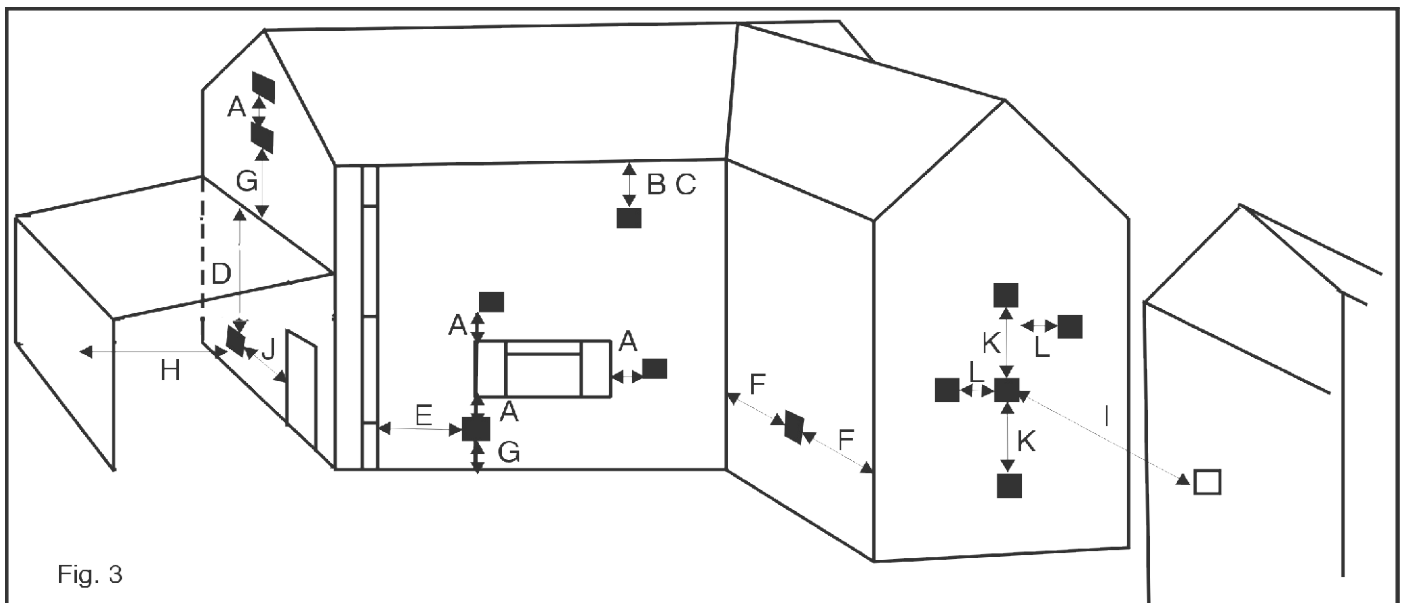

Fig. 3

3.1 SITING THE FIRE

Outside (Fig. 3): Check that the terminal location complies with the requirements of the table below.

TERMINAL POSITION	MINIMUM DISTANCE
A - Directly below, above or to the side of an openable window or other opening e.g. air brick	300mm
B - Below gutters, soil pipes or drain pipes	300mm
C - Below eaves	300mm
D - Below balconies or car port roof	600mm
E - From vertical soil pipes or drain pipes	300mm
F - From internal or external corners	600mm
G - Above ground, roof or balcony level	300mm
H - From a surface facing a terminal	600mm
I - From a terminal facing a terminal	600mm
J - From an opening in the car port (e.g. door, window) into dwelling	1200mm
K - Vertically from a terminal on the same wall	1500mm
L - Horizontally from a terminal on the same wall	300mm

Note that in England and Wales the Building Regulations require a terminal guard to be fitted if the terminal is less than 2m (6ft 6in) from the level of any ground, balcony, flat roof or place to which any person has access and which adjoins the wall in which the outlet is situated. A suitable guard assembly is available from GDC Limited. The part number is 994371. In Scotland, although the Building Standards (Scotland) do not require a terminal guard to be fitted, the fitting of a guard as detailed above is recommended.

INSIDE:

1. Allow 75mm access at each side of the heater for servicing, e.g. Changing the battery
2. Curtains must be 150mm clear at the top of the heater and 50mm at the sides and must not be closeable over the front of the fire.
3. A wooden or combustible shelf may be fitted over the fire. The minimum height of the underside of the shelf of 125mm depth must be 130mm. For shelves of greater depth, allow an additional clearance of 15mm for every 25mm additional shelf depth.
4. A minimum clearance to combustible material of 500mm is required around the heater.

4.0 PREPARATION OF WALL

NOTE: The following instructions relate to normal brick walls. If the wall is wholly or partly of combustible material, a combustible wall kit (optional extra) must be used. Refer to Section 4.4.

Check the wall thickness. Four different sizes of flue available for wall thickness up to 508mm as shown below. The medium flue is packed with the heater, the other lengths must be ordered specially.

Min (Telescopic) -	150mm to 203mm
Short	- 75mm to 203mm
Medium	- 200mm to 356mm
Long	- 356mm to 510mm

- 4.1 Place the template against the wall ensuring the top is level. For hearth mounting, ensure that the centre of the flue is 351mm above the hearth. Mark the positions of the flue and four fixing holes and remove the template.
- 4.2 Cut the hole for the flue making sure that it is straight and level. This can be done with either a 135mm diameter core drill or hammer and chisel. If neatly drilled no making good is necessary. If not it will be necessary to make good the hole especially at the terminal end where the flue seal will be located and the inside wall face to achieve a good seal.
- 4.3 Use the template to mark the fixing holes if necessary. Drill the four fixing holes to a minimum depth of 57mm using 6mm diameter masonry drill and insert the plugs.
- 4.4 COMBUSTIBLE WALLS
 1. For installation on walls constructed or comprising combustible materials, reference should be made to the requirements of BS 5440 and the Building Regulations.
 2. Timber Framed Housing: For a timber framed house, the fire can be installed as directed in The Institute of Gas Engineers Utilization Procedure *IGE/UP/7 GAS INSTALLATIONS IN TIMBER FRAME BUILDINGS*.
 3. The combustible wall kit is suitable for walls in which the combustible part is not more than 195 mm thick measured from the inside of the building.
 4. The combustible wall kit required is RW number 994530, GC No. 154 759. If the whole of the wall is of combustible material, the outer wall plate must be used, requiring access to the outside of the building.
 5. If the screws and the wall plugs supplied are not suitable for a particular application, proprietary cavity wall fixings may be used.
 6. Proceed as detailed in Section 4 for brick walls, **EXCEPT** for the following points: -
 - (a) Cut the hole for the flue to a diameter of 178 mm through the plaster board taking care not to damage the Vapour Control Layer (VCL).
 - (b) Cut the VCL 10 mm less in diameter than the hole just cut in the plasterboard. This will ensure a seal around the flue liner.
 - (c) Continue the 178 mm diameter hole through the remainder of the combustible material. If the outer leave of the wall is constructed of non-combustible material then cut the hole 135 mm diameter making allowances for the shrinkage of the timber frame.[†]
 - (d) Measure the thickness of the combustible part of the wall and cut the flue liner to this length, cutting off the end without the fixing brackets. Fit the liner to the sealing plate using the screws provided.
 - (e) Push the liner through the VCL taking care not to damage the VCL, and ensuring that the liner **DOES NOT** protrude into the cavity by more than 10 mm.
 - (f) If the wall is wholly of combustible material, install the outer wall plate centrally over the hole from the outside as shown in the diagram below. It is recommended that a silicone sealing compound is applied to the inner face of the wall plate to provide a watertight installation.
 - (g) Fit the flue, see the Fit Flue section in the Installation Instructions provided with the appliance. **NOTE:** When determining the flue length, measure the wall thickness from the face of the outer wall plate.
 - (h) Slide the rope seal over the flue, until it touches the back of the heater, prior to removing the tape from the flue foam sealing strip.
 - (i) Before installing the flue into the wall is necessary to provide a moisture barrier around the flue at the point which will be in the centre of the cavity. Either of the following methods are acceptable: -
 - (i) Wrap a wire which will not cause corrosion tightly around the flue.
 - (ii) Form a bead of mastic or silicone around the flue.

[†] Note: It is not necessary to allow for shrinkage of timber frames in existing buildings where the necessary length of time has elapsed to allow for any contraction of the timber frame.

Fig 3B

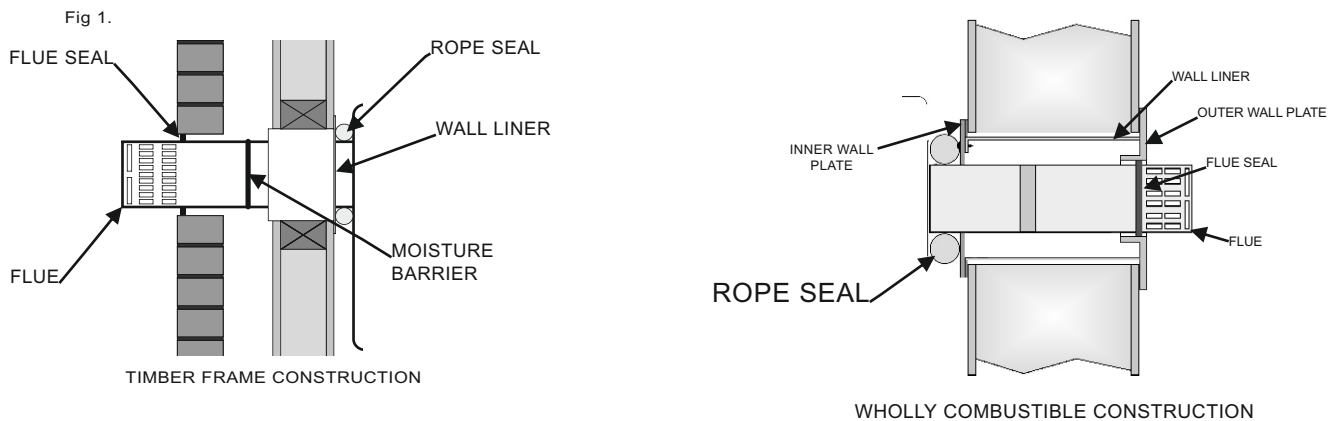

5.0 PREPARATION OF FIRE

5.1 Remove Outer Case

- Remove the door mask by first lifting upwards to clear the retaining pins and then swinging it out from the fire bottom first.
- Pull off the control knob.
- Remove the four screws, two either side of the fire securing the outer case.
- Lift the outer case away from the fire and put in a safe place.
- Remove the glass door by removing the wingnuts on the door surround. Lift off the glass door and put in a safe place.

5.2 Fit Flue

- Place the heater face down taking care to protect any soft surface.
- Fit the flue and air ducts to the back of the heater using the gaskets and screws provided. This operation is made easier by using the screws to tap the holes before assembly. The four screws for the flue duct are already fitted to the fire. The flanges of the ducts are marked 'TOP' to indicate the way in which the ducts are to be fitted. Note: do not remove the two middle slotted screws.

NOTE: The flue and air ducts do not need cutting unless the short flue assembly is being fitted. In this case measure the wall thickness. Then subtract this length from 203mm to give the length 'B' shown in Fig. 4B. Cut this length from the plain ends of both the inner flue and the inner air ducts.

Fig. 4A

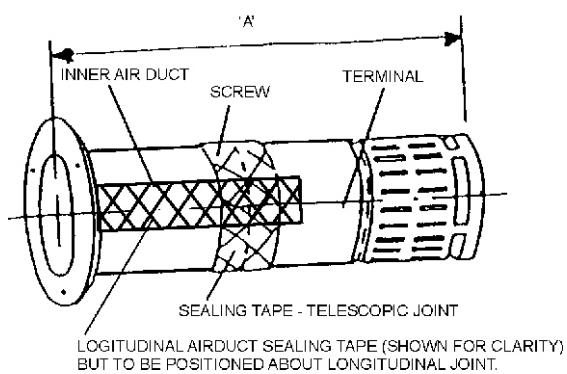

Fig. 4B

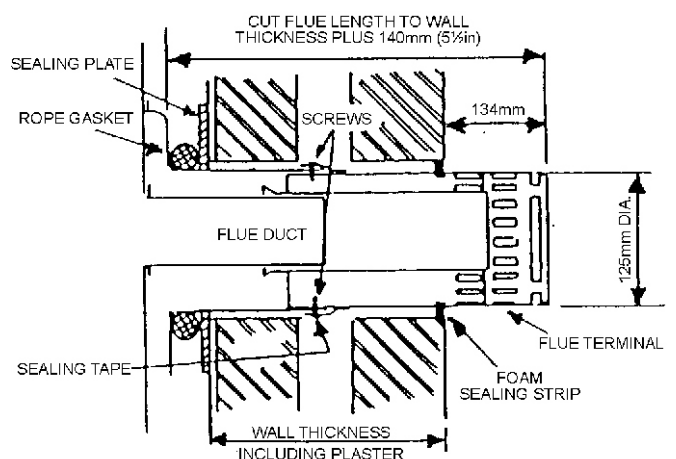
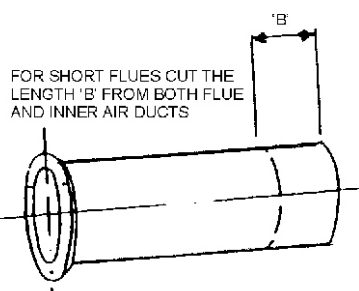

Fig. 4C

- (c) Adjust the flue length: First measure the wall thickness and add 140mm to give the overall length of flue 'A'. Fit the terminal assembly to the ducts already fitted to the heater. The top of the assembly is marked 'TOP'. Set the overall length of the flue to the dimension 'A' (Fig. 4A). Drill 2.7mm diameter for the fixing screws but do not fit them yet. Remove the flue terminal.
- (d) Slide the sealing rope gasket and the sealing plate over the air duct as shown in Fig. 4C. Refit the terminal and secure it with the screws provided. Seal the joints using the self-adhesive tape provided.
- (e) Remove the tape from the foam sealing strip on the terminal. Do not remove the tape before the fire is ready to be installed as the foam strip commences to expand once the tape is removed. The rate of expansion however, is low and there will be adequate time to install the heater, after which the foam strip will continue to expand and fill the gap between the flue and the wall. If for any reason the sealing strip has already expanded before the heater is installed, it can simply be compressed by hand until it is flush with the surface of the flue.
- (f) Insert the two top wall fixing screws, leaving the plain shank projecting to allow the keyhole top fixing holes to go over them. Offer the fire with the flue through the wall and hook the keyholes over the screws. Insert the lower wall fixing screws and secure all four screws.
- (g) If a terminal guard is required (optional extra) fit it with the kit supplied ensuring that it is concentric with the terminal.

5.3 Connect to Gas Supply (Using rigid or semi rigid tubing incorporating a service cock)

With the outer case removed, the gas inlet pipe is located at the right hand side of the fire. Connect the fire to the gas supply via the union elbow provided. This union elbow should be fitted to the end of the supply pipe and then held in position onto the flare whilst this is engaged. Tighten the flare nut with a spanner. The union elbow has Rp¼ (¼ in B.S.P. internal) thread for supply pipe.

5.4 Test for Gas Soundness (Refer to BS 6891 : 1988)

The gas installation, including the meter, should be inspected and tested for soundness and purged.

5.5 Install Fuel Effect (See Fig. 5)

Remove the coal effect from its pack. The coal effect is a one piece assembly and has a 'tunnel' cut out at one end. Fit the coal effect so that this tunnel is over the pilot burner on the right side of the firebox. The coal effect should come to rest on the full length inner front support and also on the two rear coal supports.

5.6 Replace Glass Door

Refit the glass door ensuring all studs protrude through the door evenly. Replace the wingnuts and tighten evenly.

Fig. 5

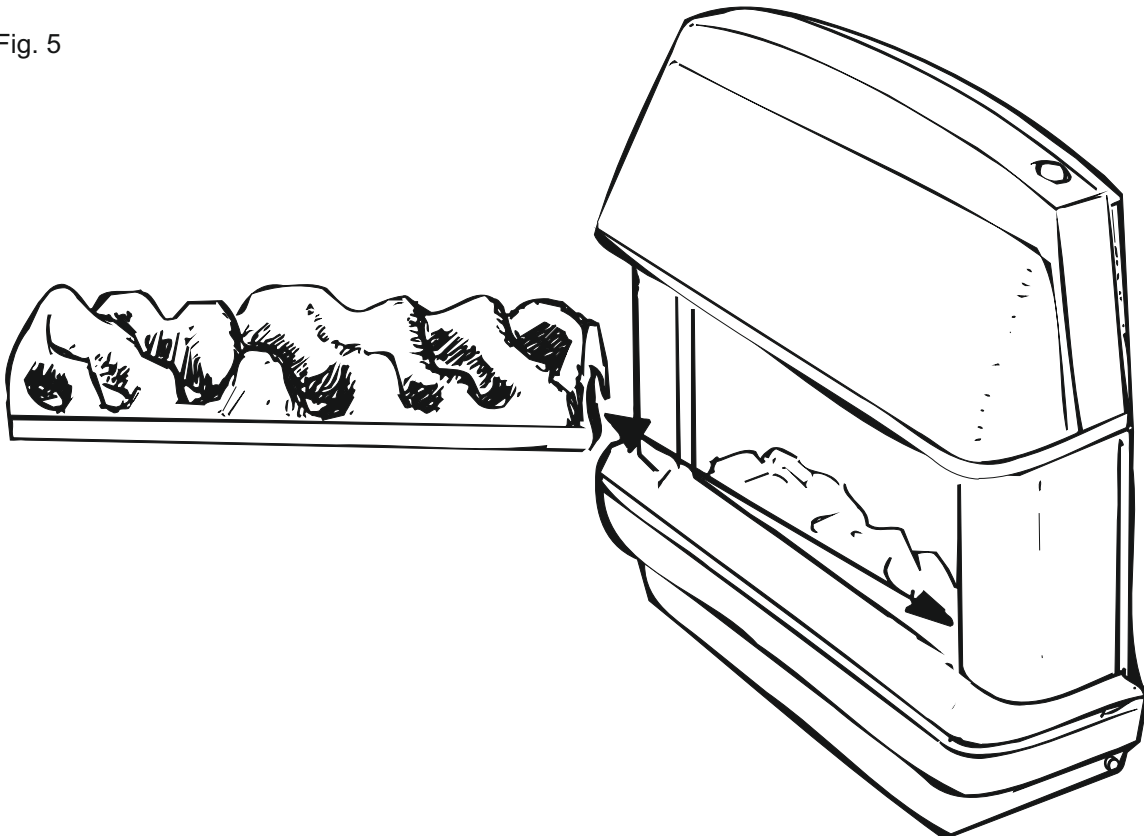

6.0 COMMISSIONING

6.1 Check the Gas Pressure and F.S.D. Operation

Remove the pressure test point sealing screw located on the gas tap and connect a pressure gauge to the test point. Temporarily fit the control knob.

- Light the fire. Please refer to the Users Instructions. Turn the control knob to the full on position marked HIGH.
 - Check that the burner pressure is $17.5\text{mbar} \pm 1.0\text{mbar}$ (7.0 in w.g. ± 0.4) cold. The fire is designed to give the correct heat input on Natural Gas at 20mbar (8 in w.g.) inlet pressure and no adjustment is provided in the fire. Turn off the fire. Wait 3 minutes then turn the control knob directly to the full on position marked HIGH. The pressure should read ZERO to confirm the FSD has shut off the gas. Remove the pressure gauge and replace the pressure test screw. Re-light the fire and test for gas soundness around the sealing screw using a suitable leak detection fluid.
 - Check ignition performance.
- WARNING: If you want to re-light a hot fire wait three minutes before doing so.

6.2 Refit Outer Case and Remaining Components

Pull off the knob. Replace the outer case by placing it over the fire right hand side first and ensure that the spindle enters the hole in the knob housing before swinging the left side of the case onto the fire. Fit four screws two each side to secure the case. Drop the spindle washer over the spindle and refit the control knob. Refit the door mask. Fit the decorative rail by inserting between the finials and into the holes in same.

6.3 Instruct User (Refer to Users Instructions)

Make sure that the user understands the following:-

- How to light and operate the fire.
- Demonstrate the removal and replacement of the glass door and the removal and replacement of the ceramics. Advise on the need to clean these items regularly.
- Advise that for safe and efficient operation, the fire should be serviced annually by a Gas Safe registered Engineer.
- When the fire is first lit a slight smell may be noticed but this will quickly clear away with use.
- Advise the customer that they should read their Users instructions before operating the fire and always follow the advice in the Section headed "Cleaning your Fire".
- The control knob adaptor may be fitted to assist with the operation of the fire (See Fig. 13). Leave with the User if not fitted.

Hand over the Users Instructions.

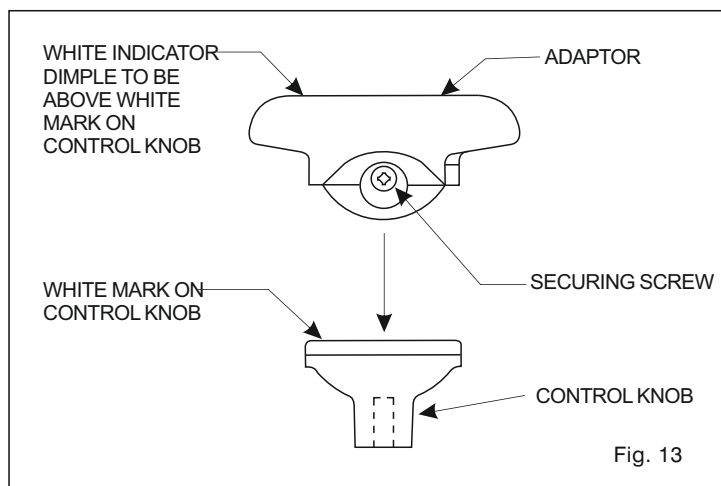

PART 2 - SERVICING

Important Notes: TURN OFF THE GAS SUPPLY BEFORE COMMENCING ANY SERVICING, ALWAYS TEST FOR GAS SOUNDNESS AFTER SERVICING OR EXCHANGING ANY COMPONENT.

It is recommended that the appliance is serviced at least once a year.

1. REMOVE OUTER CASE

- Remove the decorative rail from the finials.
- Remove the door mask by first lifting upwards to clear the retaining pins and then swinging it out from the fire bottom first.
- Pull off the control knob.
- Remove the four screws, two either side of the fire securing the outer case.
- Lift the outer case away from the fire and put in a safe place. Recover the spindle washer.

2. GAS TAP ASSEMBLY

Remove outer case (1. above) and after isolating gas supply disconnect the inlet elbow.

- Removal:** Withdraw the spring clip securing the extension spindle assembly to the gas tap spindle and remove the extension spindle assembly. Undo the union nuts on the tap outlet and remove pilot feed pipe. Disconnect the thermocouple at the gas tap end and the leads from the spark generator. Remove the two screws securing the gas tap to the support bracket on the fire. Manoeuvre the gas tap complete with inlet pipe away from the fire after disconnecting the inlet pipe clamp.
- Replacement:** Ensure that the new gas tap is in the OFF position by turning the spindle clockwise as far as possible. Peel off the tape on the pilot outlet and ensure that the pilot filter is retained in the port. Refit the tap using the reverse procedure to its removal. Refit the spindle assembly. NOTE: With the tap in the OFF position, the flat of the spindle extension faces towards the right of the fire. Check that the tap functions correctly. Replace the outer case.

3. BURNER ASSEMBLY

Remove the outer case (1. above). Isolate the fire from gas and disconnect the inlet elbow. Remove the glass door (10 wingnuts) and coal bed and put in a safe place. Remove the wingnut on the left side of the firebox, 6 screws holding the burner mounting plate to the right side of the firebox and 2 screws securing the gas tap to its mounting bracket. Disconnect the spindle extension and the leads from the spark generator, remove the pipe clamp securing the inlet pipe. Remove the burner, pilot and gas tap assembly by sliding the unit to the right and out of the firebox.

NOTE: If the fire had been previously installed in a fire surround with a restricted access on the right side then it will be necessary to remove the fire from the wall to remove the burner assembly as previously detailed. Alternatively it is possible under these circumstances to remove the control/pipework assembly from the burner first and to withdraw the burner through the front firebox opening. After removing the burner assembly from the fire detach the feed pipes from the gas tap to the injectors at the injector end. By withdrawing the injectors from the burner mounting plate the main burner becomes free and can be exchanged. When fitting the replacement burner transfer the aeration cover from the old burner. Re-assemble into the fire following the reverse procedure to dis-assembly.

4. MAIN BURNER INJECTORS

After removing the outer case (1. above) access to the injectors is achieved by first removing the respective injector feed pipe then withdrawing the injector. Only withdraw one injector at a time. The upper injector is size 180 and feeds gas to the centre burner section and the lower injector is size 160 and feeds gas to the outer burner sections.

5. PILOT INJECTOR (SIT No. 34)

- Release the tubing nuts at each end of the gas supply tube and remove the tube taking care not to lose the pellet filter in the pilot outlet of the gas tap. The injector is held captive by the olive in the burner.
- Replace the injector with a new one. Re-connect the supply tube and tighten the nuts.

6. PILOT FILTER

Proceed as in 5(a) above to remove the gas supply tube. Remove the filter in the pilot outlet of the gas tap. Replace with a new filter and re-assemble.

7. THERMOCOUPLE

- Release the tubing nuts at each end of the thermocouple and remove.
- Fit a new thermocouple and tighten the nuts.

8. SPARK ELECTRODE

- Undo the tubing nut of the thermocouple at the pilot end and release the thermocouple.
- Disconnect the ignition lead at the electrode.
- Undo the tubing nut of the electrode and remove the electrode.
- Replace with a new electrode and re-assemble in the reverse manner. Do not over tighten the nut.

9. PILOT BURNER

Release pilot feed tube, thermocouple and spark electrode as detailed in 5, 7 and 8 above. Remove 4 screws securing the pilot burner to the support plate and withdraw the pilot burner. Transfer gasket from the old pilot to the new pilot and fit the new pilot. Re-assemble the remaining components in the reverse manner to removal.

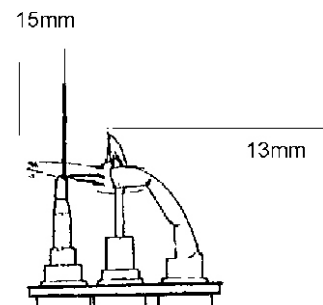

SHORT LIST OF PARTS

G.C. NUMBER	MAKERS NUMBER	DESCRIPTION
159772	991979	Coal Bed
	991725	Control Knob
	987623	Gas Tap c/w switch
393878	820363	Spark Electrode
379044	822131	Pilot Filter
159766	822205	Thermocouple
159760	991635	Door Assembly
	987632	Ignition Lead
	987633	Lead - switch/spark generator (2 off)



Robinson Willey

GDC Group Ltd, Millbrook House, Grange Drive,

Hedge End, Southampton, SO30 2DF.

Telephone: 0844 879 35 88

E-mail: info@robinsonwilley.co.uk website: www.robinsonwilley.co.uk

Robinson Willey is a Trading Division of the GDC Group Ltd