



*Fire Your Imagination*

# Huntingdon 20/30/40

Conventional Flue Log Effect Stove

With Upgradeable Control Valve



## Instructions for Use, Installation and Servicing

For use in GB, IE (Great Britain and Republic of Ireland)

### **IMPORTANT**

**THE OUTER CASING, FRONT AND GLASS PANEL BECOME EXTREMELY HOT DURING OPERATION AND WILL RESULT IN SERIOUS INJURY AND BURNS IF TOUCHED. IT IS THEREFORE RECOMMENDED THAT A FIREGUARD COMPLYING WITH BS 8423:2002 IS USED IN THE PRESENCE OF YOUNG CHILDREN, THE ELDERLY OR INFIRM.**

This product contains a heat resistant glass panel. This panel should be checked during Installation and at each servicing interval. If any damage is observed on the front face of the glass panel (scratches, scores, cracks or other surface defects), the glass panel must be replaced and the appliance must not be used until a replacement is installed. Under no circumstances should the appliance be used if any damage is observed, the glass panel is removed or broken.

It is essential that ALL of the screws that retain the glass frame are replaced and tightened correctly. Under no circumstances should the appliance be operated if any of these screws are loose or missing.

These Instructions must be left with the appliance for future reference and for consultation when servicing the appliance. Please make the customer aware of the correct operation of the appliance before leaving these instructions with them.

The commissioning sheet found on Page 3 of this Instruction manual must be completed by the Installer prior to leaving the premises.

# Contents

## Huntingdon 20/30/40 - Conventional Flue

Covering the following models:

Model		HUNTINGDON 20		HUNTINGDON 30		HUNTINGDON 40	
		NAT GAS	LPG	NAT GAS	LPG	NAT GAS	LPG
Black	Tracery Door	515-035	515-405	515-004	515-413	515-161	515-565
	Clear Door	515-071	515-441	515-009	515-453	515-188	515-592
Ivory	Tracery Door	515-044	515-423	515-154	515-484	515-170	515-574
	Clear Door	515-080	515-468	515-061	515-505	515-197	515-601
Matt Ivory	Tracery Door	515-053	515-432	515-212	515-536	515-179	515-583
	Clear Door	515-089	515-477	515-299	515-570	515-206	515-619

**Appliance Commissioning Checklist .....3**

**User Instructions .....4**

**Installation Instructions .....12**

Technical Specifications ..... 12

Site Requirements ..... 14

Installation ..... 16

Commissioning .....26

**Servicing Requirements .....27**

Fault Finding ..... 27

How to replace parts ..... 28

Basic spare parts list ..... 39

Service Records ..... 43



If you have purchased your stove or fire from an authorised stockist within our Expert Retailer Network, then automatically your product will carry a 2 year warranty as standard. The 2 year warranty can be further extended to a total warranty period of 5 years by registering your Gazco Stove or Fireplace within one month of the latter of the purchase date or installation date. Accordingly, the start date for the warranty period is the date of purchase. During the registration process, the Expert Retailer details will be required for your Extended Warranty to be activated. Any product purchased outside of our Expert Retailer Network will carry a standard 12 month, non-extendable warranty.

It is a condition of the Extended Warranty that the installation complies with the relevant Building Regulations and is carried out by a suitably trained and qualified individual (GasSafe in the UK or equivalent in other countries) with the certificate of installation and the Commissioning Report on Page 3 completed and retained by the end user.

Full terms and conditions are detailed in the Warranty Statement on the Gazco website [www.gazco.com](http://www.gazco.com). In the event of any conflict of information the wording on the website shall prevail.

Important Note: Should any problems be experienced with your product, claims must first be submitted to the Expert Retailer where the appliance was purchased from who will offer immediate assistance or contact Gazco on your behalf.



**It is a requirement of the Building Regulations 2010 that the installation of this appliance is notified to the Local Authority. It is the responsibility of the GasSafe registered installer to carry out this notification to the Local Authority via the GasSafe register Competent Persons Scheme in England and Wales (different rules apply in Scotland and Northern Ireland).**

**When the installation has been notified, GasSafe will send a Building Regulations Compliance Certificate to you containing details of the work completed. Please ensure that the person responsible for the installation of this appliance completes this notification and records it in the Appliance Commissioning Checklist on page 3.**

**IT IS YOUR RESPONSIBILITY TO COMPLY WITH THE BUILDING REGULATIONS AND BE ABLE TO PRODUCE THIS CERTIFICATE SHOULD IT BE REQUIRED IN THE FUTURE.**

# Appliance Commissioning Checklist

To assist us in any guarantee claim please complete the following information:-

## IMPORTANT NOTICE

Explain the operation of the appliance to the end user, hand the completed instructions to them for safe keeping, as the information will be required when making any guaranteed claims.

FLUE CHECK	PASS	FAIL	
1. Flue Is correct for appliance			
2. Flue flow Test			
3. Spillage Test			
GAS CHECK			
1. Gas soundness & let by test			
2. Standing gas pressure	mb		
3. Appliance working pressure (on High Setting) NB All other gas appliances must be operating on full	mb		
4. Gas rate	m <sup>3</sup> /h		
5. Does Ventilation meet appliance requirements			
6. Have controls been upgraded (Upgradeable models only)	8455 Standard	YES	NO
	8456 Programmable Thermostatic and Timer	YES	NO
SAFETY CHECK			
1. Glass checked to ensure no damage, scratches, scores or cracks.			
2. Door secured correctly and all screws replaced			
BUILDING CONTROL NOTIFICATION	YES	NO	
1. Installer notified GasSafe/Local Authority of installation via Competent Persons Scheme?			

## RETAILER AND INSTALLER INFORMATION

<b>Retailer</b> .....	<b>Installation Company</b> .....
.....	.....
.....	.....
<b>Contact No.</b> .....	<b>Engineer</b> .....
<b>Date of Purchase</b> .....	<b>Contact No.</b> .....
<b>Model No.</b> .....	<b>GasSafe Reg No.</b> .....
<b>Serial No.</b> .....	<b>Date of Installation</b> .....
<b>Gas Type</b> .....	

# User Instructions

## Welcome

*Congratulations on purchasing your Huntingdon stove, if installed correctly Gazco hope it will give you many years of warmth and pleasure for which it was designed.*

*The purpose of this manual is to familiarise you with your appliance, and give guidelines for its installation, operation and maintenance. If, after reading, you need further information, please do not hesitate to contact your Gazco retailer.*

## WARNING



**In the event of a gas escape or if you can smell gas, please take the following steps:**

- Immediately turn off the gas supply at the meter/emergency control valve
- Extinguish all sources of ignition
- Do not smoke
- Do not operate any electrical light or power switches (On or Off)
- Ventilate the building(s) by opening doors and windows
- Ensure access to the premises can be made

**Please report the incident immediately to the National Gas Emergency Service Call Centre on 0800 111 999 (England, Scotland and Wales) , 0800 002 001 (N. Ireland) or in the case of LPG, the gas supplier whose details can be found on the bulk storage vessel or cylinder.**

**The gas supply must not be used until remedial action has been taken to correct the defect and the installation has been recommissioned by a competent person.**

## 1. General



**IMPORTANT: ALWAYS WEAR THE GLOVES PROVIDED WHEN HANDLING AN IVORY PAINTED APPLIANCE.**

- 1.1 Installation and servicing must only be carried out by a competent person whose name appears on the GasSafe register. To ensure the engineer is registered with GasSafe they should possess an ID Card carrying the following logo:



- 1.2 In all correspondence, please quote the appliance type and serial number, which can be found on the data badge located under the top plate between the carcass and firebox or on the Commissioning Checklist on Page 3.
- 1.3 **Do not** place curtains above the appliance: You must have 300mm (1') clearance between the appliance and any curtains at either side.
- 1.4 The manufacturer considers the full outer casing of this appliance to be a working surface and it will become hot whilst in operation. A suitable guard is recommended to protect young children, the aged and the infirm.
- 1.5 No furnishings or other objects should be placed within 1 metre of the front of the appliance.
- 1.6 If a shelf is fitted, a distance of 225mm above the appliance is required.
- 1.7 Do not attempt to burn rubbish in this appliance.
- 1.8 This appliance must only be operated with the door secured firmly in position. If any cracks appear in the glass the appliance must not be used until the glass panel is replaced.
- 1.9 This product is guaranteed for 5 years from the date of installation, as set out in the terms and conditions of sale between Gazco and your local Gazco retailer. Please consult with your local Gazco retailer if you have any questions. In all correspondence always quote the Model Number and Serial Number.

# User Instructions

## 2. Operating the Appliance

2.1 The control valve is at the foot on the right-hand side of the appliance. It has two controls, see Diagram 1:

1. The right-hand knob controls the pilot ignition.
2. The left-hand knob controls the main burner.

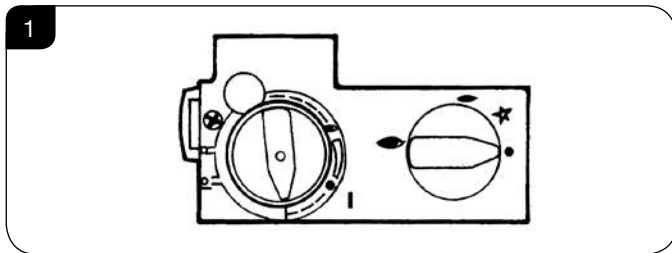

2.2 Refer to separate instructions if your appliance is upgraded to include battery remote control. The instructions below apply whether or not you have the remote upgrade.

### Lighting the Pilot

2.3 To start the left-hand and right-hand control knobs must both point to off (●):

2.4 Press in the right-hand control knob and rotate anti-clockwise until a click is heard. Continue to press in. The knob points to the pilot (←).

The pilot is lit

2.5 Keep the knob depressed for 10 seconds before releasing. The pilot remains lit.

Repeat the above steps if the pilot does not stay lit.

**NOTE: If the pilot goes out, the Interlock system prevents you lighting again for a short period.**

2.6 If, after repeating the above steps the pilot does not light, contact your Retailer or Installer.

2.7 Turn the right-hand knob to the left to main burner setting (↔).

### Adjusting the Flame height

2.8 You can now adjust the flame height and temperature using the left-hand control knob.

2.9 Turn the left-hand knob anti-clockwise to increase the flame height.

2.10 Turn clockwise to decrease the height.

**YELLOW FLAMES APPEAR WHEN THE APPLIANCE HAS REACHED SUFFICIENT HEAT – (10 TO 20 MINUTES). IF THE APPLIANCE IS EXTINGUISHED OR GOES OUT IN USE, WAIT 3 MINUTES BEFORE TRYING TO RELIGHT.**

## 3. Turning OFF the Appliance

3.1 To turn the main burner off turn the left-hand knob until it points to off (●). Just the pilot remains lit.

3.2 Press in and turn the right-hand knob until it points to off (●). The pilot goes out.

## 4. Upgrading the Appliance

4.1 The appliance is fitted with a control valve that can easily be upgraded to battery powered remote control. There are two versions of this control which can be obtained through your local Gazco retailer.

There is no requirement for this upgrade to be carried out by an approved GasSafe engineer. However Gazco recommend that this task is undertaken by a suitably competent person.

4.2 This upgrade can be fitted before or after installation but if side clearances are limited then it will be easier to upgrade the appliance before installation. Full instructions are included with the kit.

### Standard Remote Control (PART NUMBER 8455)

4.3 This remote control can control the gas appliance after the pilot has been lit. It can turn the main burner on and regulate it from low through to high and back again. It can turn the main burner off leaving the pilot burning.

### Thermostatic and Timer Remote Control (PART NUMBER 8456)

4.4 This remote control can control the gas appliance after the pilot has been lit.

### MANUAL MODE

Can be used to turn the main burner on and manually regulate it from low through to high and back again. It can also be used to turn the main burner off leaving the pilot burning.

### AUTO MODE

Will automatically regulate the room to a pre-set temperature.

### TIMER MODE

Will turn the appliance on and off according to a pre-set programme and automatically regulate the room temperature during the two on periods.

# User Instructions

## 5. Cleaning the Appliance



**WARNING: NEVER CLEAN THE APPLIANCE WHILE IT'S HOT. THE APPLIANCE STAYS HOT FOR A LONG TIME AFTER SHUTDOWN.**

**IMPORTANT: THE OUTER PANNELLING OF THE APPLIANCE IS MADE FROM CAST IRON. USE CAUTION WHEN INSTALLING, REMOVING AND STORING AS THE COMPONENTS ARE HEAVY AND SHOULD BE HANDLED CAREFULLY.**

- 5.1 Make sure the appliance and surrounds are cool before cleaning.

### REMOVING THE DOOR

- 5.2 For rear flue exit lift the top of the appliance off and put to one side.
- 5.3 For top flue exit lift and support the top to give clearance, see Diagram 2.

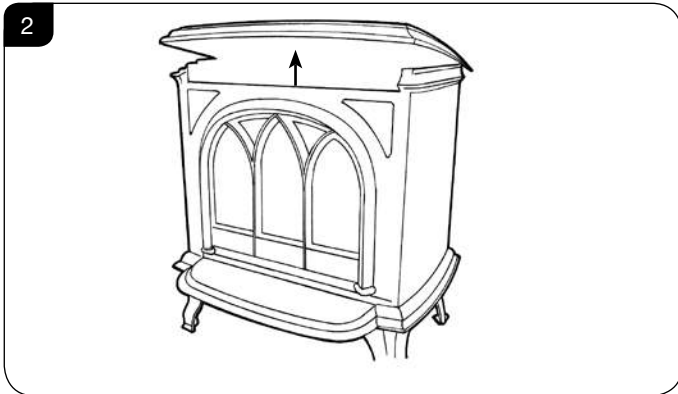

### Huntingdon 20 and 40

- 5.4 Supporting the door top and bottom pull forwards whilst lifting the front upwards at a 45° angle until it is clear of the slots and pull away from the appliance, see Diagram 3.

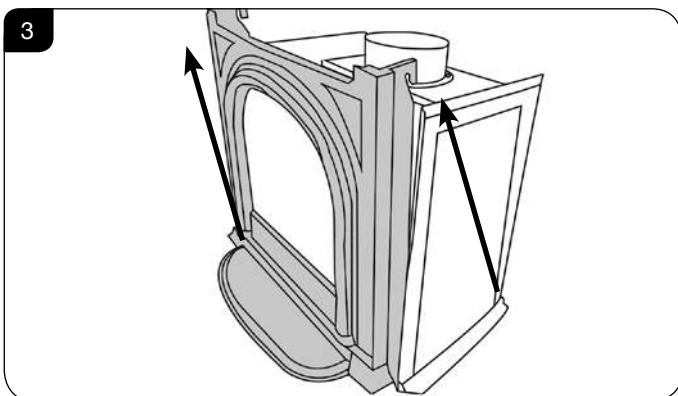

### Huntingdon 30

- 5.5 Lift the front upwards until it is clear of the slots and pull away from the appliance, see Diagram 4.

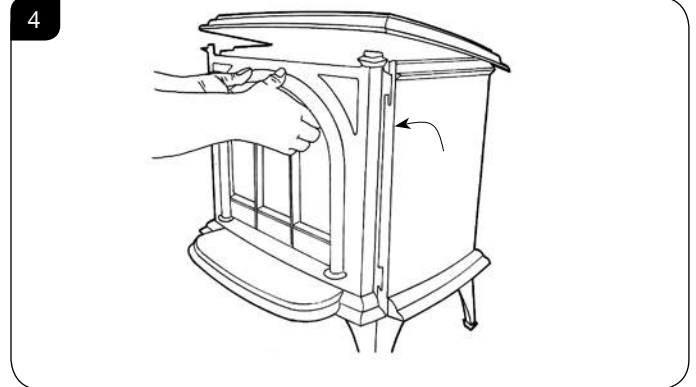

### All Models

- 5.6 Remove the glass frame by undoing the fixing screws and lifting clear, see Diagram 5. **Take care to support the glass window panel when removing the screws.**

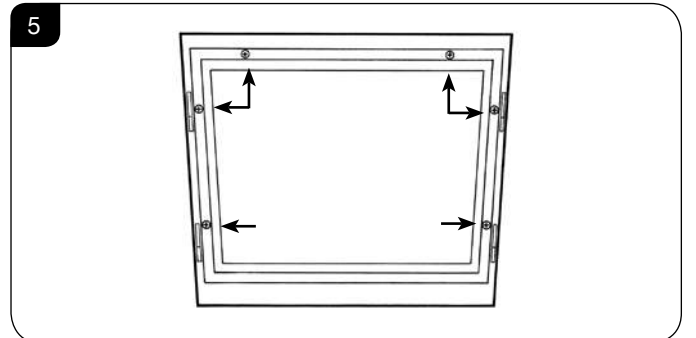

- 5.7 Place carefully to one side.
- 5.8 Lift out the log guard.
- 5.9 Carefully remove the ceramic fuel bed components and set aside. Protect the floor coverings and follow the advice given in Section 7.
- 5.10 The logs do not require cleaning. Do not use a vacuum cleaner or brush to clean the logs, any large pieces of debris can be removed by hand.
- 5.11 Ensure any debris is removed from the burner ports.
- 5.12 Replace the ceramics see Section 7.
- 5.13 Ensure that the fibreglass seal on the back of the glass frame is intact and replace the screws working from the top down. Tighten the screws evenly **DO NOT OVERTIGHTEN**, see Diagram 4.
- NEVER OPERATE THE APPLIANCE WHEN THE GLASS FRAME IS REMOVED OR BROKEN.**
- 5.14 Replace ALL of the securing screws ensuring that a screw is present in all fixing slots.

# User Instructions



**UNDER NO CIRCUMSTANCES SHOULD THE APPLIANCE BE USED IF ANY OF THE GLASS FRAME RETAINING SCREWS ARE LOOSE OR MISSING.**

5.15 Use a damp cloth to clean the outer casing of the appliance.

## 6. Cleaning Ivory Painted Appliances

- 6.1 **Allow the appliance to cool thoroughly to avoid risk of burns.**
- 6.2 Ivory painted appliances require special attention when cleaning. They have been coated with a high quality paint that should give many years of service. However, this colour will mark more easily and require cleaning more than other models.
- 6.3 Take care when touching the appliance to avoid marking the paint. Most marks can be removed using a mild soap solution and a clean lint free cloth. The finish can also be refreshed using aerosol touch up paint (product code 2055) available from your Gazco retailer.

## 7. Arrangement of Fuel Bed

### Advice on handling and disposal of fire ceramics



The fuel effect of the log version of this appliance is made from Refractory Ceramic Fibre (RCF), a material which is commonly used for this application.

Protective clothing is not required when handling these articles, but we recommend you follow normal hygiene rules of not smoking, eating or drinking in the work area and always wash your hands before eating or drinking.

To ensure that the release of RCF fibres are kept to a minimum, during installation and servicing a HEPA filtered vacuum is recommended to remove any dust accumulated in and around the appliance before and after working on it. When servicing the appliance it is recommended that the replaced items are not broken up, but are sealed within heavy duty polythene bags and labelled as RCF waste.

RCF waste is classed as stable, non-reactive hazardous waste and may be disposed of at a licensed landfill site.

Excessive exposure to these materials may cause temporary irritation to eyes, skin and respiratory tract; wash hands thoroughly after handling the material.

**LOGS MUST BE POSITIONED ACCORDING TO THE FOLLOWING INSTRUCTIONS TO GIVE THE CORRECT FLAME EFFECT**

## 8. Log Layout

### Huntingdon 20 layout

All logs can be identified by a letter (A - E) on their underside. Logs B and E also have holes to locate each onto a burner stud.

- 8.1 Ensure the burner tray is clean and free from any debris, see Diagram 6.

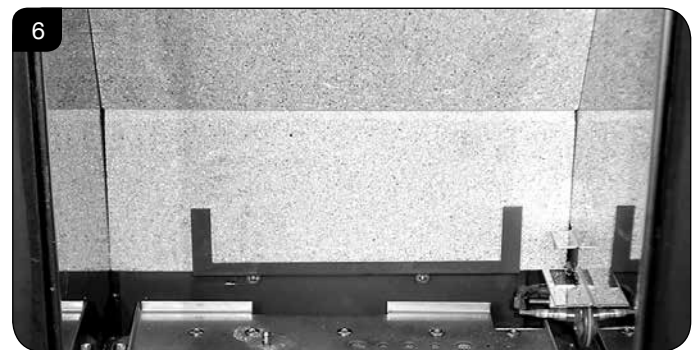

- 8.2 Place Log A on the higher rear bracket and push up against the back panel, see Diagram 7.

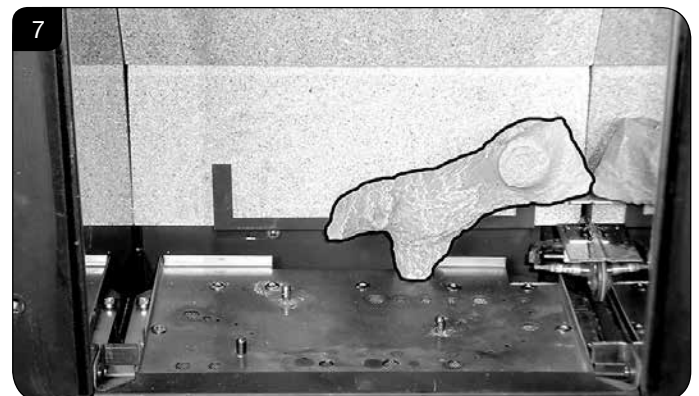

- 8.3 Place Log B over the two middle studs on the burner tray, see Diagram 8.

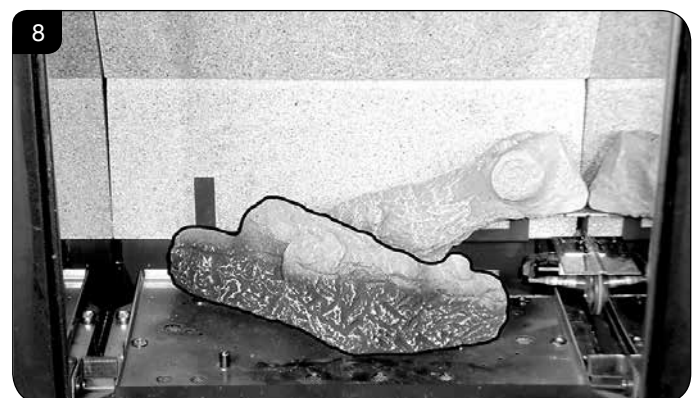

# User Instructions

- 8.4 Place Log E onto the stud and behind the tag on the left hand side of the burner tray. Rest against Log B, see Diagram 9.

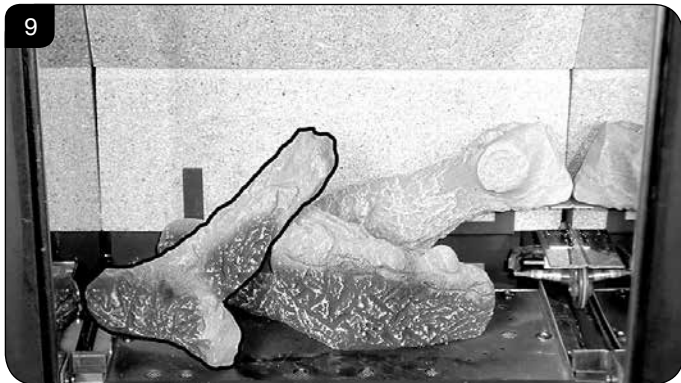

- 8.5 Place the small Ember at the front left of the firebox against the rear of the log support bracket to obscure the reflection of the burner screw.

Place the larger Ember on the lower bracket above the pilot on the right hand side with the thicker edge facing the front and flat edges to the base and side, see Diagram 10.

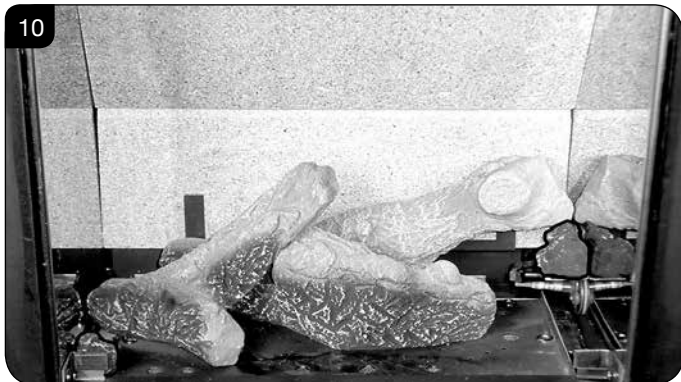

- 8.6 Log C rests on the cutout on Log E and is pushed up to the side and rear of the firebox, see Diagram 11.



- 8.7 Place the pointed bottom of log D into the corner of the burner tray and rest on the location stud in log B, see Diagram 12.

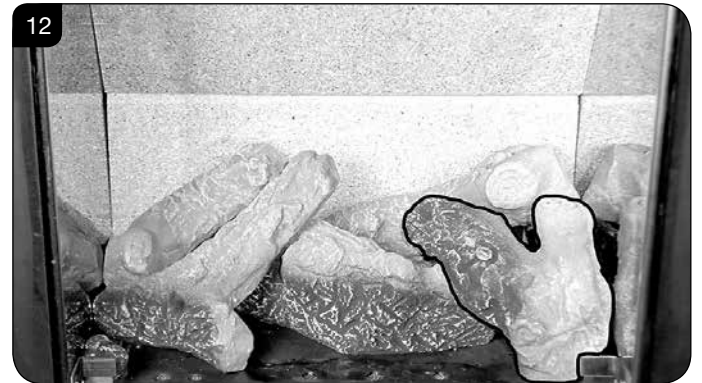

- 8.8 Use some of the Embaglow provided and cover the ports in the burner tray with a liberal amount of fibres. Use a small piece in front of the log on the left hand side and a long strip in front of log B, see Diagram 13.

NOTE: It is not necessary to use all of the Embaglow.

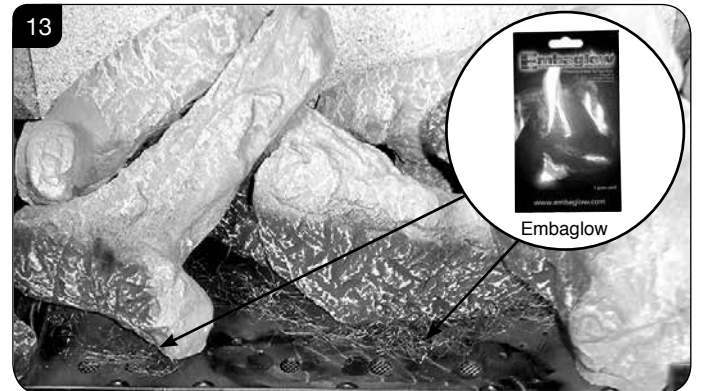

- 8.9 Lower log guard into position, see Diagram 14.





# User Instructions

## Huntingdon 30 layout

- 8.10 Ensure the burner tray is clean and free from any debris, see Diagram 14.

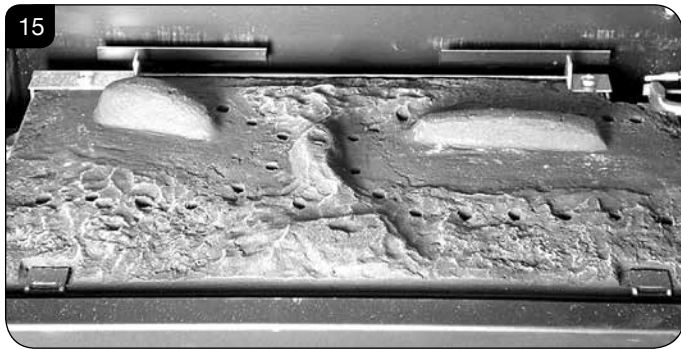

The three logs that make up the fuel bed are visually distinct and fit into specific parts on the burner tray.

- 8.11 Place the rear log into position between the rear brackets and pushed up against the back panel, see Diagram 16.

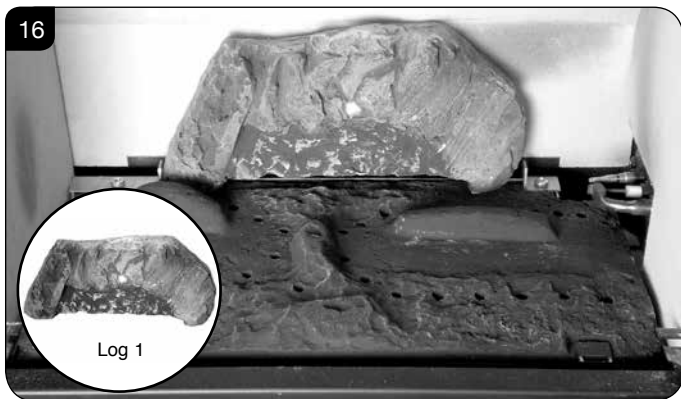

- 8.12 Place the second log into the left hand groove on the burner tray, see Diagram 17. The log should butt up against the raised molding and the left hand side liner.

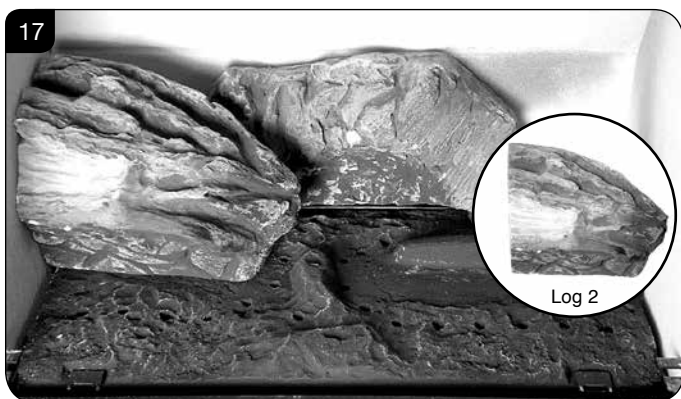

- 8.13 Place the third log into the groove on the right hand side, see Diagram 18. The log should butt up against the raised molding and the right hand side liner.

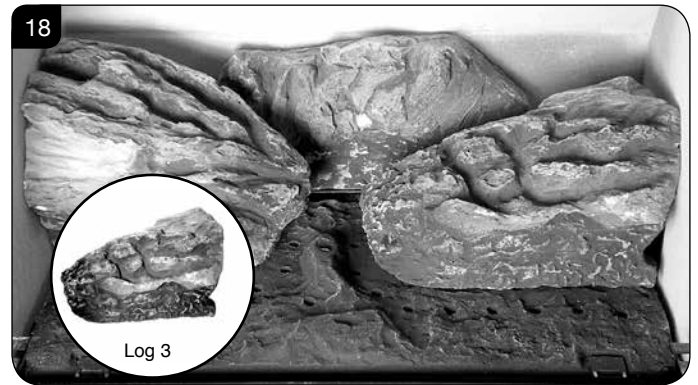

- 8.14 Once the logs are in there are two embers which can be loosely placed at the front of the fuel bed and cover the tabs securing the burner tray, see Diagram 19.

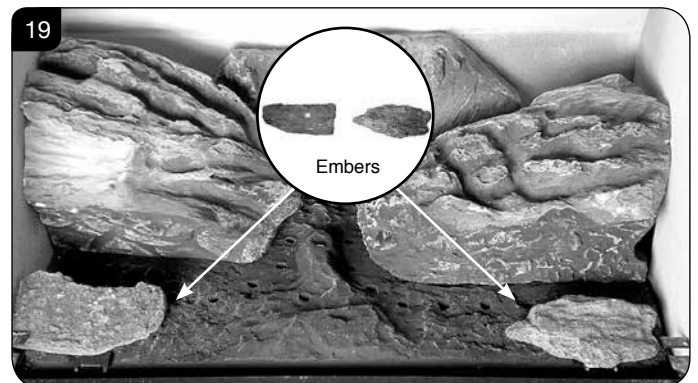

- 8.15 Use some of the Embaglow provided and cover the ports in the burner tray with a liberal amount of fibres, see Diagram 20.

**It is essential to cover the port in the middle of the burner tray in order to get the most visually appealing flame picture.**

NOTE: It is not necessary to use all of the Embaglow.

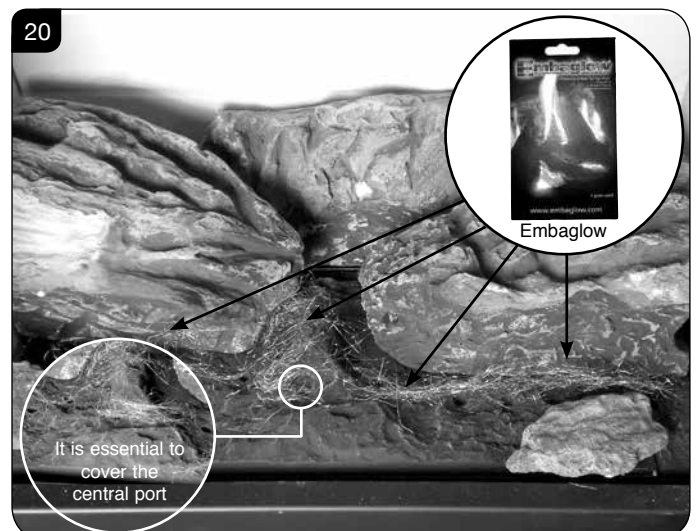

# User Instructions

8.16 Fix log guard into position, see Diagram 21.

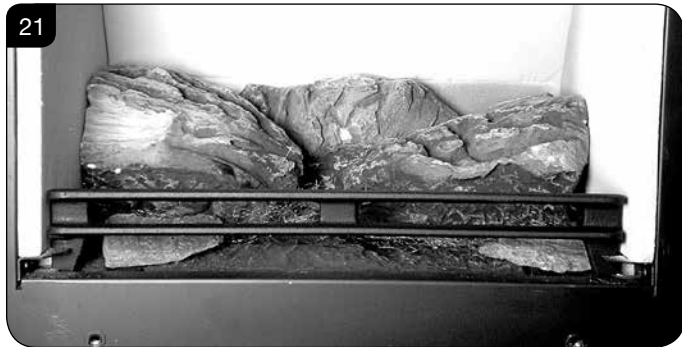

## Huntingdon 40 layout

The logs for the fuel bed are clearly individually labelled, A to D.

8.17 Ensure the burner tray is clean and free from any debris, see Diagram 22.

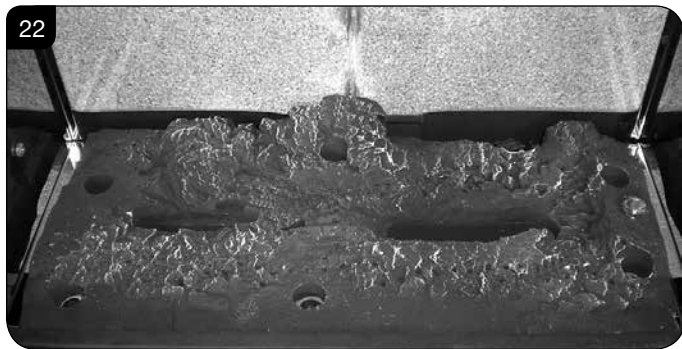

8.18 There are 3 embers. Place 2 embers in the back corners of the burner, resting in the cut outs, see Diagram 23. Place the last ember loosely at the front of the fuel bed to cover the hole in the centre.

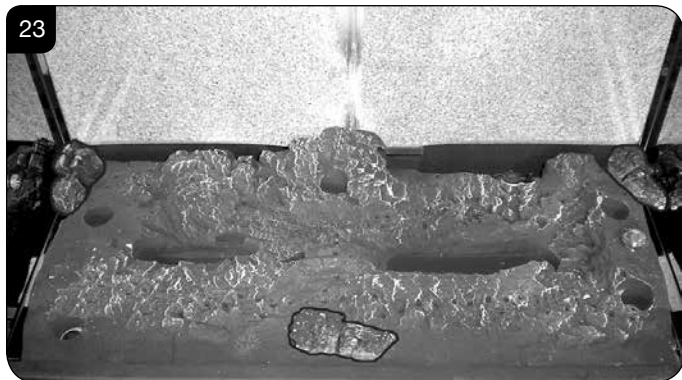

8.19 Place Log D on the left hand side of the burner. There is a hole on the underside of Log D which fits over the raised stud on the left of the burner. The back of the log should rest flat against the back panel, see Diagram 24.

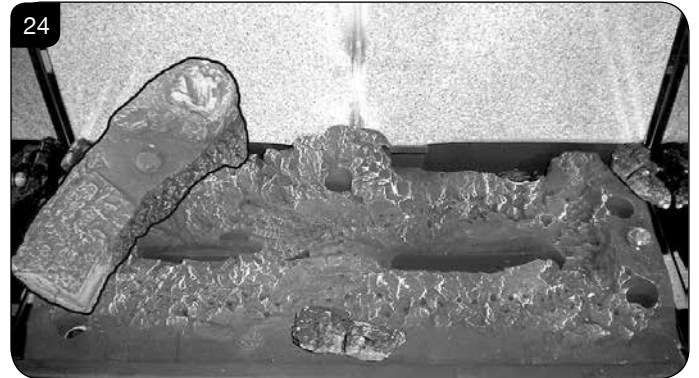

8.20 Place Log B on top of Log D. There is a hole on the underside of Log B which fits over the raised stud on Log D to secure in place. The right hand side of the log rests in the groove in the burner, see Diagram 25.

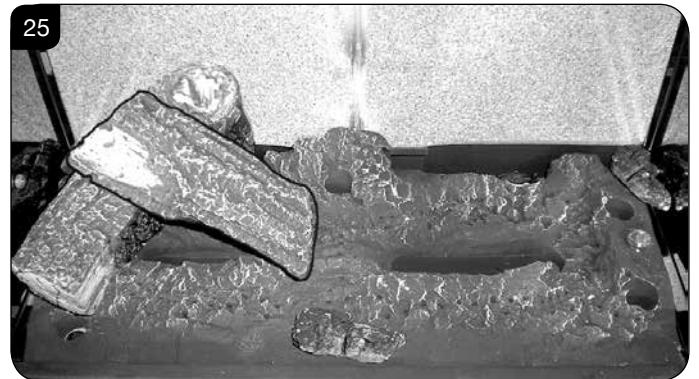

8.21 Place Log C on the right hand side of the burner. There is a hole on the underside of Log C which fits over the raised stud on the right of the burner. The back of the log should rest flush against the back panel, see Diagram 26.

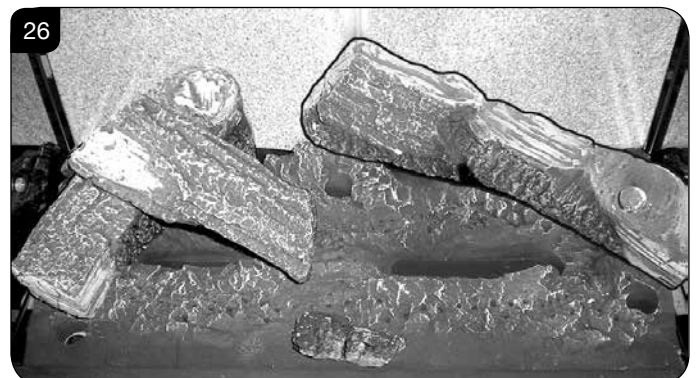

# User Instructions

- 8.22 Place the log guard into position on the grooves on the sides of the firebox, see Diagram 27.



- 8.23 Place Log A across Log C. There is a hole on the underside of Log A which fits over the raised stud on Log C to secure in place. The small cut out on the left side of the log rests onto the log guard, see Diagram 28.



- 8.24 Once the logs are in place use some of the Embaglow wire wool provided and cover the ports in the burner tray with a liberal amount of fibres, in the highlighted areas shown in Diagram 29.  
**NOTE: It is not necessary to use all of the Embaglow. IT IS ESSENTIAL TO KEEP THE REAR PORT FREE FROM OBSTRUCTION.**



- 8.25 Use a ceramic glass product generally sold for cleaning ceramic hobs to clean the glass front.

The glass frame must be refitted to the appliance following cleaning or servicing.

- 8.26 Ensure that the rope seal on the back of the glass frame is intact and replace the screws working from the top down. Tighten the screws evenly **DO NOT OVER TIGHTEN**, see Diagram 30.

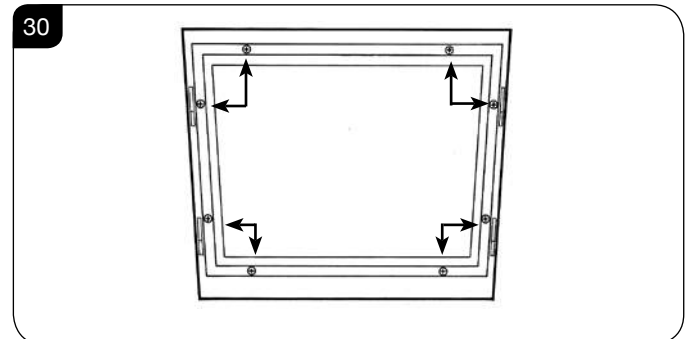

- 8.27 Replace ALL of the securing screws ensuring that a screw is present in all fixing slots.

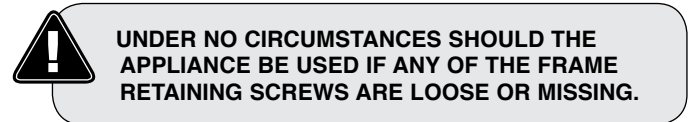

**UNDER NO CIRCUMSTANCES SHOULD THE APPLIANCE BE USED IF ANY OF THE FRAME RETAINING SCREWS ARE LOOSE OR MISSING.**

**NEVER OPERATE THE APPLIANCE WHEN THE GLASS FRAME IS REMOVED, OR THE GLASS IS BROKEN.**

- 8.28 With the top still supported or removed refit front by locating in grooves and lowering into place, see Diagram 31.

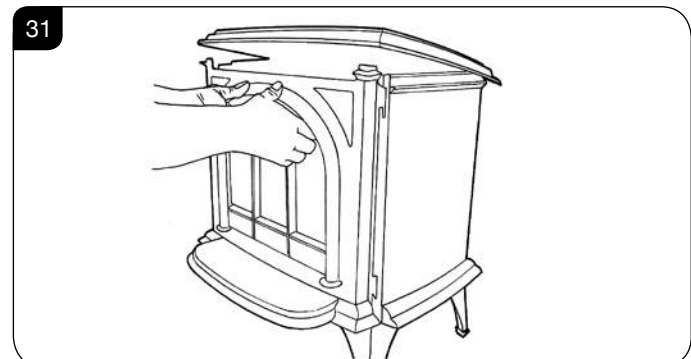

- 8.29 Now replace top, see Diagram 32.

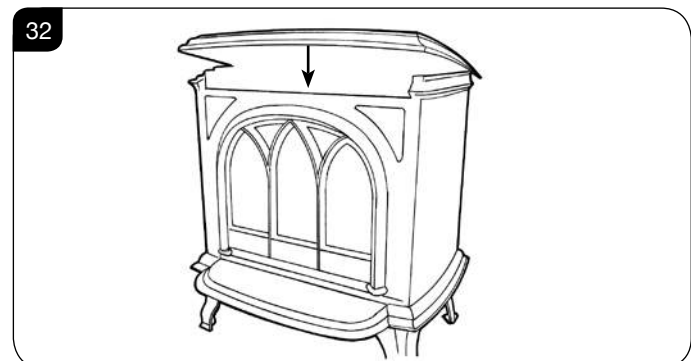

# Installation Instructions

## 8. Flue Sure System

- 8.1 The appliance is fitted with the Gazco Flue Sure System, which will act to cut off the gas supply to the burners in the event of incorrect operation of the flue. If the system acts to cut off the gas supply, this indicates that there is insufficient flue pull. If this occurs a minimum of 10 minutes should be allowed before trying to relight. Continued operation of this safety device means there may be a serious problem with the flue system. A qualified GasSafe engineer should inspect this.

**DO NOT USE THE APPLIANCE UNTIL AN ENGINEER SAYS IT IS SAFE TO DO SO.**

## 9. Flame Failure Device

- 9.1 This is a safety feature incorporated on this appliance which automatically switches off the gas supply if the pilot goes out and fails to heat the thermocouple.

**IF THIS OCCURS DO NOT ATTEMPT TO RELIGHT THE APPLIANCE FOR 3 MINUTES.**

## 10. Running In

- 10.1 During initial use of a new Gazco appliance a strong odour will be encountered as various surface coatings become hot for the first time. Although these odours are harmless it is recommended that the appliance is operated on maximum for 4 to 8 hours in order to fully burn off these coatings. After this period the odours should then disappear.

If the odours persists, please contact your installer for advice.

- 10.2 During the first few hours of burning there may be discolouration of the flames. This will also disappear after a short period of use.

## 11. Servicing

- 11.1 The appliance must be serviced every 12 months by a qualified GasSafe Engineer. In all correspondence always quote the Model number and the Serial number which may be found on the Commissioning Checklist (Page 3).

## 12. Ventilation

- 12.1 This appliance requires no additional ventilation.

## 13. Installation Details

- 13.1 Your installer should have completed the commissioning sheet at the front of this book. This records the essential installation details of the appliance. In all correspondence always quote the Model number and Serial number.

## 14. Hot Surfaces

- 14.1 Parts of this appliance become hot during normal use. Regard all parts of the appliance as a 'working surface'.
- 14.2 Provide a suitable fire guard to protect young children and the infirm.

# Installation Instructions

## Technical Specification

Covering the following models:

Model		HUNTINGDON 20		HUNTINGDON 30		HUNTINGDON 40	
		NAT GAS	LPG	NAT GAS	LPG	NAT GAS	LPG
Black	Tracery Door	515-035	515-405	515-004	515-413	515-161	515-565
	Clear Door	515-071	515-441	515-009	515-453	515-188	515-592
Ivory	Tracery Door	515-044	515-423	515-154	515-484	515-170	515-574
	Clear Door	515-080	515-468	515-061	515-505	515-197	515-601
Matt Ivory	Tracery Door	515-053	515-432	515-212	515-536	515-179	515-583
	Clear Door	515-089	515-477	515-299	515-570	515-206	515-619

Model	Gas CAT.	Gas Type	Working Pressure	Aeration	Injector	Gas Rate m <sup>3</sup> /h	Input kW (Gross)		Country
							High	Low	
Huntingdon 20	12H	Natural Gas (G20)	20mbar	1 x ø6mm	185	0.314	3.3	2.0	GB, IE
	13P	Propane (G31)	37mbar	6mm x 15mm	90	0.120	3.2	2.0	GB, IE
Huntingdon 30	12H	Natural Gas (G20)	20mbar	6mm x 6mm	260	0.433	4.55	2.5	GB, IE
	13P	Propane (G31)	37mbar	1 x (14mm x 15mm)	102	0.164	4.35	2.5	GB, IE
Huntingdon 40	12H	Natural Gas (G20)	20mbar	2 x ø6mm	067	0.628	6.6	3.9	GB, IE
	13P	Propane (G31)	37mbar	2 x ø13mm	128	0.252	6.7	3.7	GB, IE
<b>Huntingdon 20 and 30:</b> Efficiency Class 2 - 75% / NOx Class 4 <b>Huntingdon 40:</b> Efficiency class 2 - 78%									
Flue Outlet Size 127mm (5") ø									
Gas Inlet Connection Size 8mm ø									
Minimum flue specification T250 / N2 / O / D / 1									
Maximum flue temperature 220°C									

**i** The net efficiency of this appliance has been measured as specified in EN613:2001 and the result after conversion to gross using the appropriate factor from Table E4 of SAP 2009 is 69.1% (Huntingdon 20 and 30) or 71.8% (Huntingdon 40). The test data has been certified by Kiwa Nederland B.V. The gross efficiency value may be used in the UK Government's Standard Assessment Procedure (SAP) for energy rating of dwellings.

# Installation Instructions

## Technical Specification

This appliance has been certified for use in countries other than those stated. To install this appliance in these countries, it is essential to obtain the translated instructions and in some cases the appliance will require modification. Contact Gazco for further information.

### PACKING CHECKLIST

Qty Description	Fixing Kit containing:-
1 x Appliance 1 x Flue infill plate 1 x Log set 1 x Packet of Embaglow	1 x Instruction manual

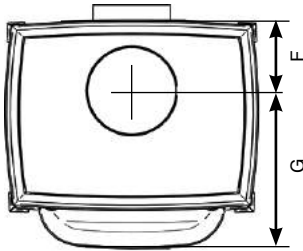

HUNTINGDON 20 & 30							
	A	B	C	D	E	F	G
<b>Huntingdon 20</b>	416	535	320	366	62	119	266
<b>Huntingdon 30</b>	553	592	357	422	96	174	305

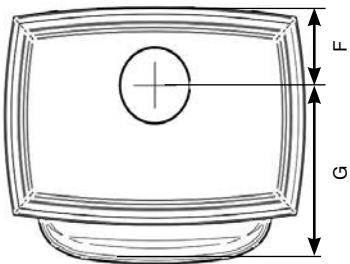
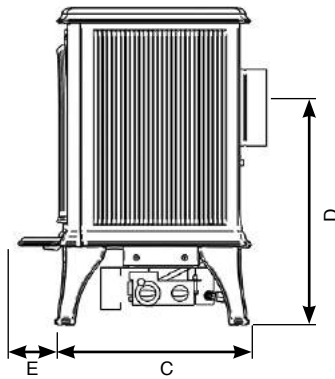
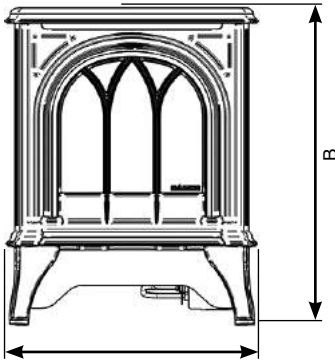

HUNTINGDON 40							
	A	B	C	D	E	F	G
<b>Huntingdon 40</b>	641	653	382	460	99	154	350

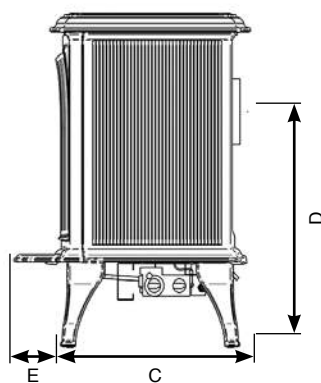
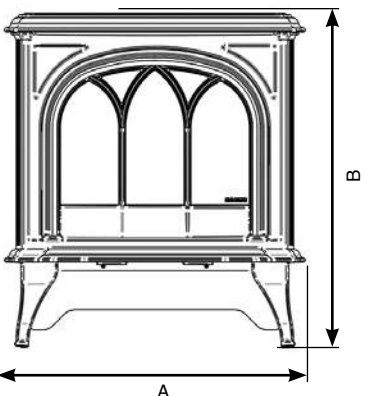

# Installation Instructions

## Site Requirements

### 1. Flue & Chimney Requirements

- 1.1 The chimney or flue system must comply with the rules in force, and must be a minimum of 127mm (5") in diameter.
- 1.2 The minimum flue height for the appliance must be 3 metres (10ft). Any horizontal flue run from the rear outlet must not exceed 100mm from the back of the appliance.
- 1.3 The chimney or flue must be free from any obstruction. Any damper plates must be removed or secured in the fully open position, and no restrictor plates fitted.
- 1.4 The chimney must be swept prior to the installation, but it need not be swept if it can be seen the chimney is clean and unobstructed throughout its entire length.
- 1.5 A 5" (127mm) liner must be used if fitting the appliance into an existing brick built chimney. Larger lined flues can work, but in some instances could cause cold start flue problems resulting in nuisance shutdown. Lined flues above 7" (175mm) are not recommended.
- 1.6 The European chimney standards now describe chimneys and flues by their temperature, pressure and resistance to corrosion, condensation and fire. To identify the correct flue system, the minimum flue specification is shown in the Technical Specification. Existing chimneys are not covered by this system.

### 2. Flue Options

**A range of Vitreous Enamel Gloss Black flue pipe is available to compliment the Huntingdon. Please contact your Gazco retailer for further information.**

### 3. Gas Supply

**THIS APPLIANCE IS INTENDED FOR USE ON A GAS INSTALLATION WITH A GOVERNED METER.**

- 3.1 Before installation, ensure that the local distribution conditions (identification of the type of gas and pressure) and the adjustment of the appliance are compatible.
- 3.2 Ensure the gas supply delivers the required amount of gas and is in accordance with the rules in force.
- 3.3 You can use soft copper tubing on the installation and soft soldered joints outside the appliance and below the fire.
- 3.4 A means of isolating the gas supply to the appliance must be provided independent of any appliance control.
- 3.5 All supply gas pipes must be purged of any debris that may have entered prior to connection to the appliance.
- 3.6 The gas supply must be installed in a way that does not restrict the removal of the appliance for servicing and inspection.

### 4. Ventilation

**IMPORTANT: Ensure any national ventilation requirements are taken into account during installation of the appliance.**

**UK ONLY:**

The Huntingdon 30 has a nominal input not exceeding 7.0kW and does not normally require any additional permanent ventilation.

**FOR THE REPUBLIC OF IRELAND REFER TO THE RULES IN FORCE FOR VENTILATION REQUIREMENTS.**

### 5. Appliance Location

- 5.1 Building Regulations state this appliance must stand on a non-combustible hearth that is at least 12mm thick and projects 50mm minimum from the base of the appliance in all directions, however Gazco recommend the hearth extends to the following dimensions, see Diagram 1.

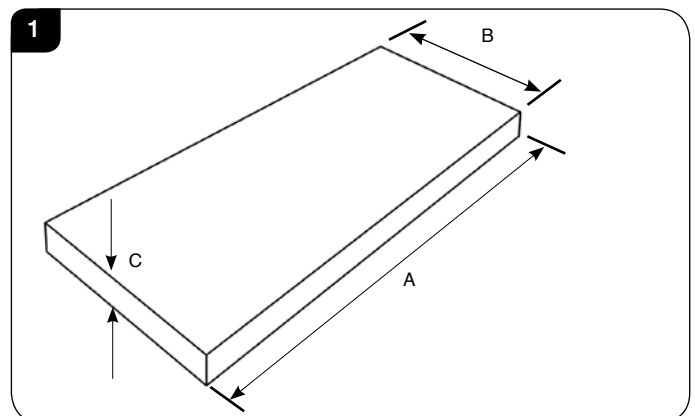

Dimension	A	B	C
Huntingdon 20	716	420	12
Huntingdon 30	853	451	12
Huntingdon 40	941	482	12

# Installation Instructions

## Site Requirements

### MINIMUM CLEARANCE

5.2 The appliance is not suitable for installation against a combustible wall. All combustible materials must be removed from behind the appliance.

5.3 **Ensure that all minimum clearances to combustible materials are complied with, see Diagrams 2 & 3.**

The specified clearances provide the minimum distance to combustible materials. If the appliance is intended to be installed into a non-combustible opening the clearance to the **sides and above** the appliance can be reduced. However, it is recommended that the specified clearances are maintained irrespective of the materials used in the construction of the opening to allow adequate air flow and access to controls. **The clearance at the rear of the appliance must always be a minimum of 50mm.**

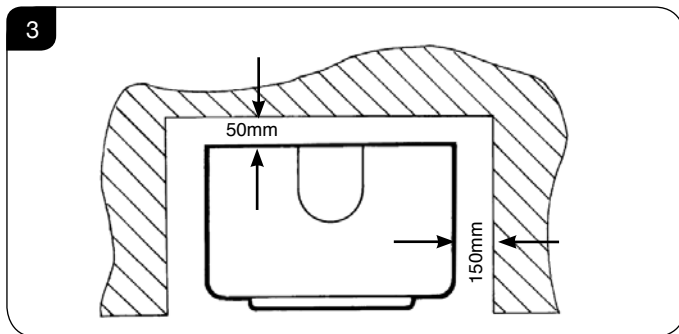
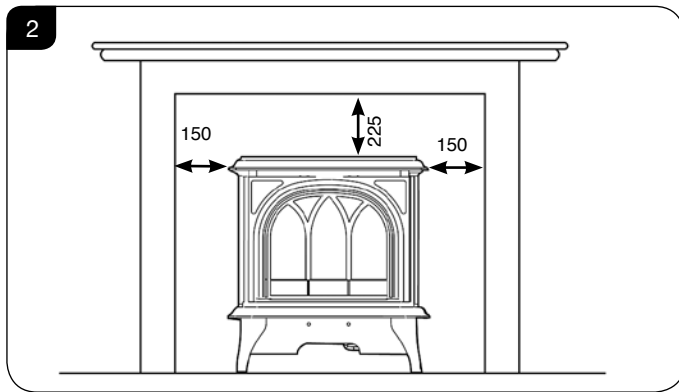

5.4 **In a non-combustible recess be careful to allow enough clearance at the sides and rear of the appliance to perform spillage tests and reach the controls.**



# Installation Instructions

## 1. Safety Precautions



**IMPORTANT: ALWAYS WEAR THE GLOVES PROVIDED WHEN HANDLING AN IVORY PAINTED APPLIANCE.**

- 1.1 For your own and other's safety, you must install this appliance according to local and national codes of practice. Failure to install the appliance correctly could lead to prosecution. **Read these instructions before installing and using this appliance.**
- 1.2 These instructions must be left intact with the user.
- 1.3 Do not attempt to burn rubbish on this appliance.
- 1.4 Keep all plastic bags away from young children.
- 1.5 Do not place any object on or near to the appliance and allow adequate clearance above the appliance.

**IF THE APPLIANCE IS EXTINGUISHED OR GOES OUT IN USE, WAIT 3 MINUTES BEFORE ATTEMPTING TO RELIGHT THE APPLIANCE.**

- 1.6 The appliance is fitted with the Gazco Flue Sure System, which will act to cut off the gas supply to the burners in the event of incorrect operation of the flue. If the system acts to cut off the gas supply, this indicates that there is insufficient flue pull. If this occurs a minimum of 10 minutes should be allowed before trying to relight. Continued operation of this safety device means there may be a serious problem with the flue system. A qualified GasSafe engineer should inspect this.
- 1.7 Do not alter or tamper with the Flue Sure System. Use only genuine Gazco replacement parts when servicing the system - refer to the Servicing Section, **Replacing Parts**.

**DO NOT USE THE APPLIANCE UNTIL AN ENGINEER SAYS IT IS SAFE TO DO SO.**



**IMPORTANT: REFER TO DATA BADGE AND TECHNICAL SPECIFICATION AT THE FRONT OF THE MANUAL TO ENSURE THE APPLIANCE IS CORRECTLY ADJUSTED FOR THE GAS TYPE AND CATEGORY APPLICABLE IN THE COUNTRY OF USE.**

**FOR DETAILS OF CHANGING BETWEEN GAS TYPES REFER TO SERVICING, SECTION 14, REPLACING PARTS.**

## Unpacking

- 1.8 Remove the appliance from its packaging, and check that it is complete and undamaged.

Put the loose ceramic parts to one side so that they are not damaged during installation.

## 2. Upgrading the Appliance

- 2.1 The appliance is fitted with a control valve that can easily be upgraded to battery powered remote control. There are two versions of this control which can be obtained through your local Gazco retailer. There is no requirement for this upgrade to be carried out by an approved GasSafe engineer. However Gazco recommend that this task is undertaken by a suitably competent person.
- 2.2 This upgrade can be fitted before or after installation but if side clearances are limited then it will be easier to upgrade the appliance before installation. Full instructions are included with the kit.

### Standard Remote Control (PART NUMBER 8455)

- 2.3 This remote control can control the gas appliance after the pilot has been lit. It can turn the main burner on and regulate it from low through to high and back again. It can turn the main burner off leaving the pilot burning.

### Thermostatic and Timer Remote Control (PART NUMBER 8456)

- 2.4 This remote control can control the gas appliance after the pilot has been lit.

#### MANUAL MODE

Can be used to turn the main burner on and manually regulate it from low through to high and back again. It can also be used to turn the main burner off leaving the pilot burning.

#### AUTO MODE

Will automatically regulate the room to a pre-set temperature.

#### TIMER MODE

Will turn the appliance on and off according to a pre-set programme and automatically regulate the room temperature during the two on periods.

# Installation Instructions

## 3. Installation of the Appliance

- 3.1 Decide whether to use top or rear flue exit.  
The appliance is factory built for rear flue exit but it can be changed to top exit by swapping the flue spigot and blanking plate located on the appliance.

### Huntingdon 30 Only

- 3.2 On Huntingdon 30 models the flue spigot must be placed in an offset position from the blanking plate to correctly align with the top plate.
- 3.3 To access the blanking plate lift off the cast top and place carefully to one side.
- 3.4 Remove the four screws holding the blanking plate to the appliance, see Diagram 1.  
Note the two additional holes in the top of the firebox.

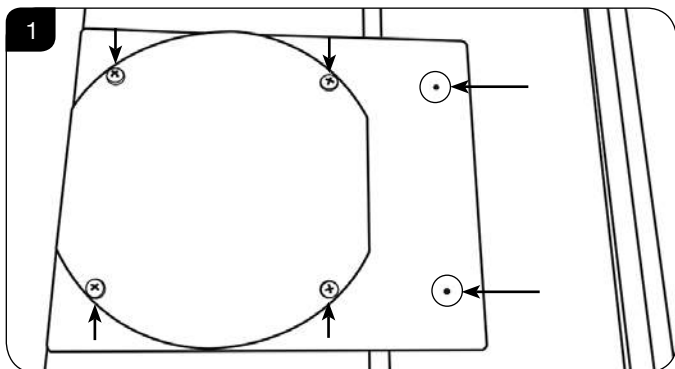

- 3.5 With the blanking plate removed there are two additional holes underneath, see diagram 2.

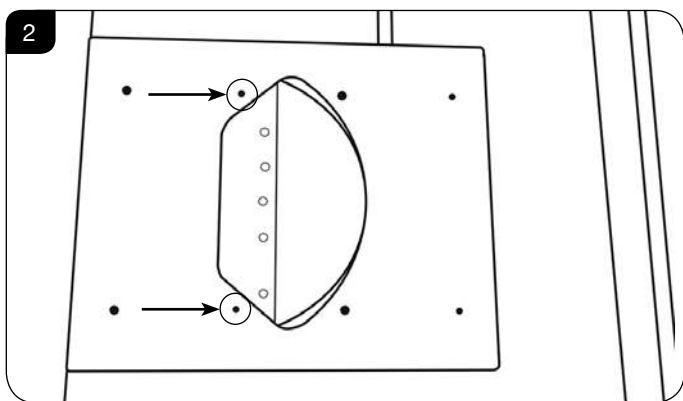

- 3.6 Position the flue spigot using the offset holes and the ones previously beneath the blanking plate. Secure the spigot and blanking plate in the new positions, see Diagram 3.

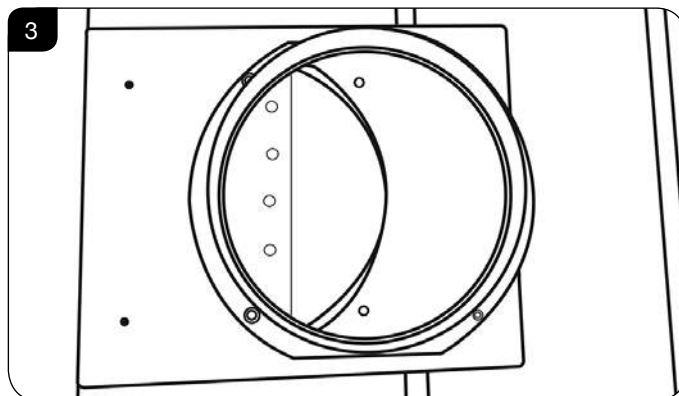

### All Models

- 3.7 Position the appliance ensuring all appropriate clearances are observed.
- 3.8 Having run the gas supply to the appliance **PURGE THE SUPPLY PIPE.**  
This is essential to expel any debris that can block the gas controls.
- 3.9 Connect the gas supply to the 8mm compression elbow at the right-hand rear corner of the appliance.  
There is a cutout in the right-hand rear leg to enable a straight connection to the rear of the appliance, see Diagram 4.

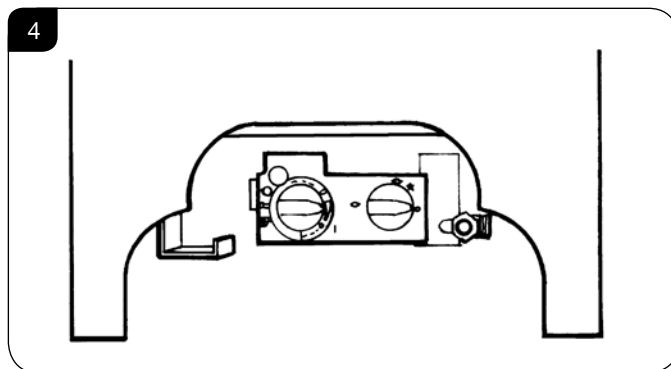

- 3.10 The flue system can now be connected to the appliance.
- 3.11 Ensure all joints are sealed with a fire resistant cement and use a self-tapping screw at the flue spigot joint.

## 4. Gas Soundness Pressure Check

- 4.1 Connect a suitable pressure gauge to the test point located on the inlet fitting and turn the gas supply on. Light the appliance and check all gas joints for possible leaks. Turn the appliance to maximum and check that the supply pressure is as stated on the databadge. Turn the gas off and replace the test point screw, turn the gas on and check the test point for leaks.

# Installation Instructions

## 5. Removing the Door



**IMPORTANT: THE OUTER PANELLING OF THE APPLIANCE IS MADE FROM CAST IRON. USE CAUTION WHEN INSTALLING, REMOVING AND STORING AS THE COMPONENTS ARE HEAVY AND SHOULD BE HANDLED CAREFULLY.**

- 5.1 For rear flue exit lift the top of the appliance off and put to one side.
- 5.2 For top flue exit lift and support the top to give clearance, see Diagram 5.

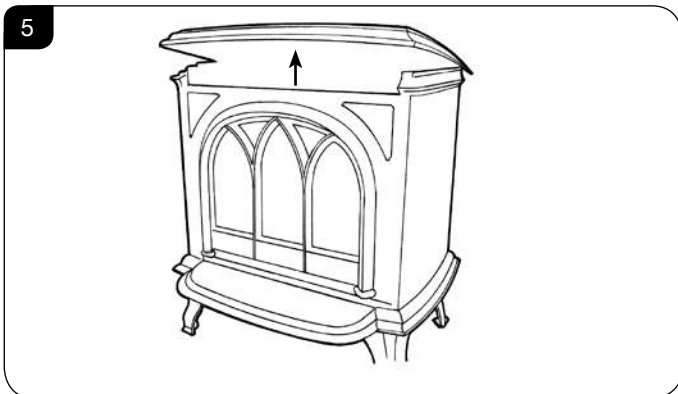

## Huntingdon 20 and 40

- 5.3 Lift the front upwards until it is clear of the slots and pull away from the appliance, see Diagram 6.

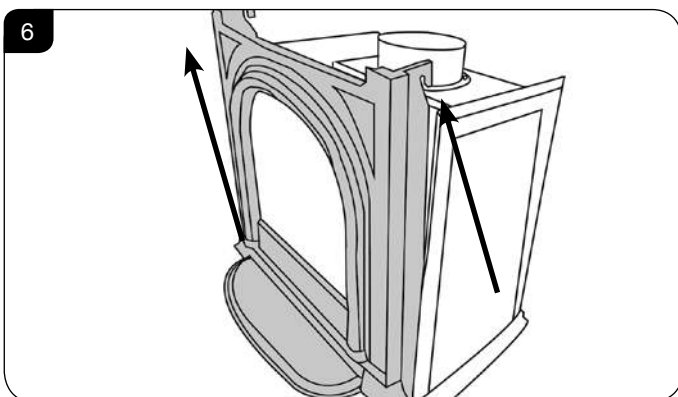

## Huntingdon 30

- 5.4 Lift the front upwards until it is clear of the slots and pull away from the appliance, see Diagram 7.

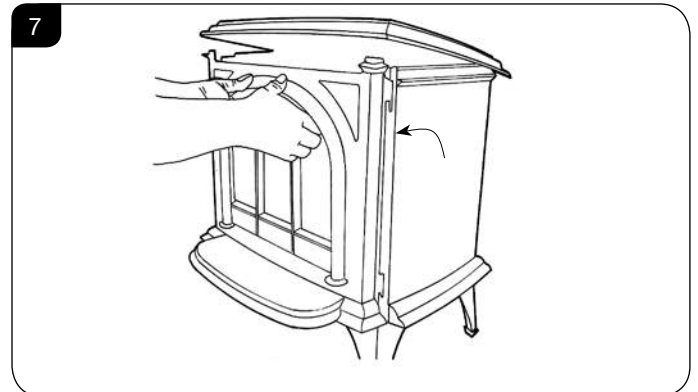

## All Models

- 5.5 Remove the glass frame by undoing the fixing screws and lifting clear, see Diagram 8. **Take care to support the glass window panel when removing the screws.**

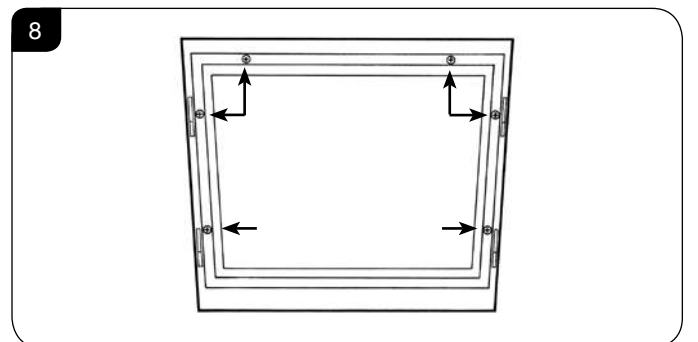

# Installation Instructions

## 6. Arrangement of Fuel Bed

### Advice on handling and disposal of fire ceramics



The fuel effect of the log version of this appliance is made from Refractory Ceramic Fibre (RCF), a material which is commonly used for this application.

Protective clothing is not required when handling these articles, but we recommend you follow normal hygiene rules of not smoking, eating or drinking in the work area and always wash your hands before eating or drinking.

To ensure that the release of RCF fibres are kept to a minimum, during installation and servicing a HEPA filtered vacuum is recommended to remove any dust accumulated in and around the appliance before and after working on it. When servicing the appliance it is recommended that the replaced items are not broken up, but are sealed within heavy duty polythene bags and labelled as RCF waste.

RCF waste is classed as stable, non-reactive hazardous waste and may be disposed of at a licensed landfill site.

Excessive exposure to these materials may cause temporary irritation to eyes, skin and respiratory tract; wash hands thoroughly after handling the material.

## 7. Log Layout

### Huntingdon 20 layout

**LOGS MUST BE POSITIONED ACCORDING TO THE FOLLOWING INSTRUCTIONS TO GIVE THE CORRECT FLAME EFFECT**

All logs can be identified by a letter (A - E) on their underside. Logs, B and E also have holes to locate each onto a burner stud.

- 7.1 Ensure the burner tray is clean and free from any debris, see Diagram 9.

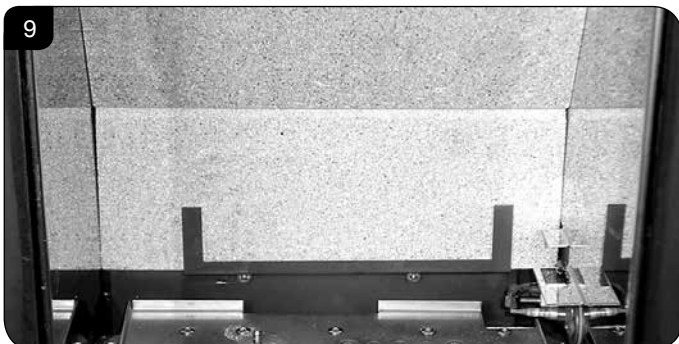

- 7.2 Place Log A on the higher rear bracket and push up against the back panel, see Diagram 10.

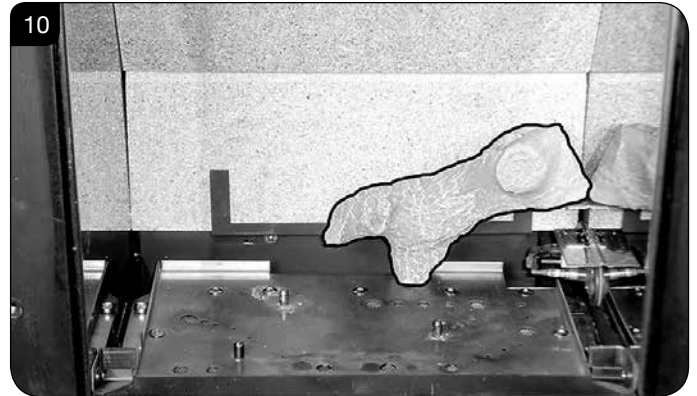

- 7.3 Place Log B over the two middle studs on the burner tray, see Diagram 11.

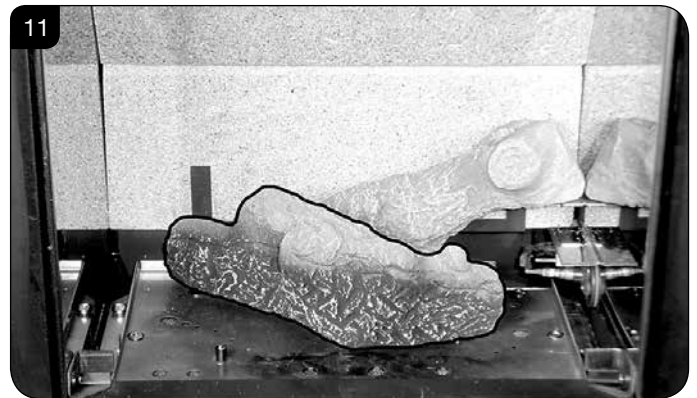

- 7.4 Place Log E onto the stud and behind the tag on the left hand side of the burner tray. Rest against Log B, see Diagram 12.

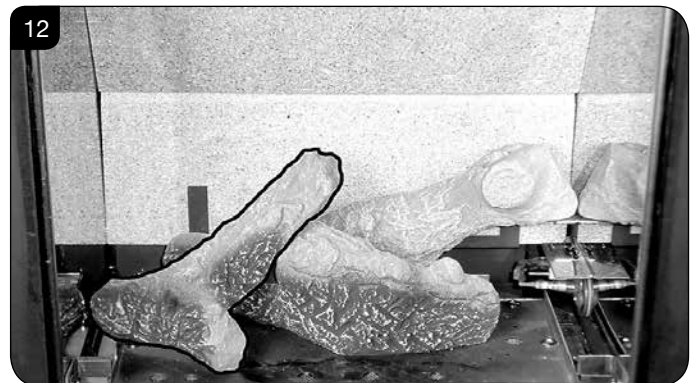

# Installation Instructions

- 7.5 Place the small Ember at the front left of the firebox, against the rear of the log support bracket to obscure the reflection of the burner screw.

Place the larger Ember on the lower bracket above the pilot on the right hand side with the thicker edge facing the front and flat edges to the base and side, see Diagram 13.

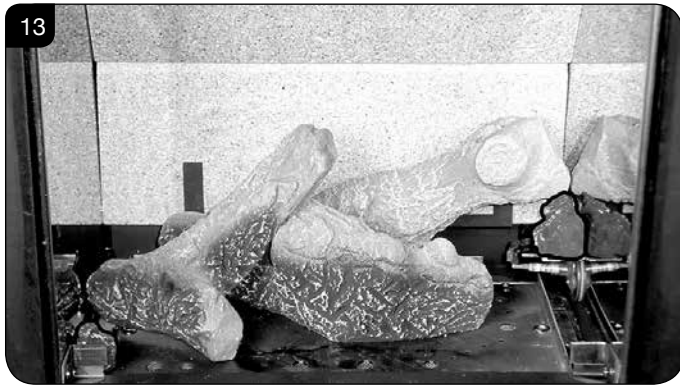

- 7.6 Log C rests on the cutout on Log E and is pushed up to the side and rear of the firebox, see Diagram 14.

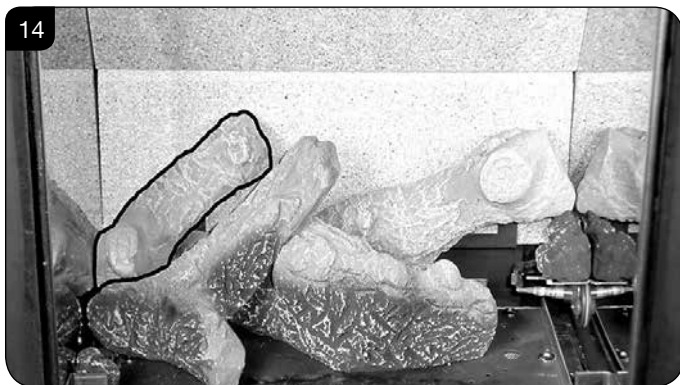

- 7.7 Place the pointed bottom of log D into the corner of the burner tray and rest on the location stud on log B, see Diagram 15.



- 7.8 Use some of the Embaglow provided and cover the ports in the burner tray with a liberal amount of fibres. Use a small piece in front of the log on the left hand side and a long strip in front of log B, see Diagram 16.

NOTE: It is not necessary to use all of the Embaglow.



- 7.9 Lower log guard into position, see Diagram 17.



## Huntingdon 30 layout

- 7.10 Ensure the burner tray is clean and free from any debris, see Diagram 18.

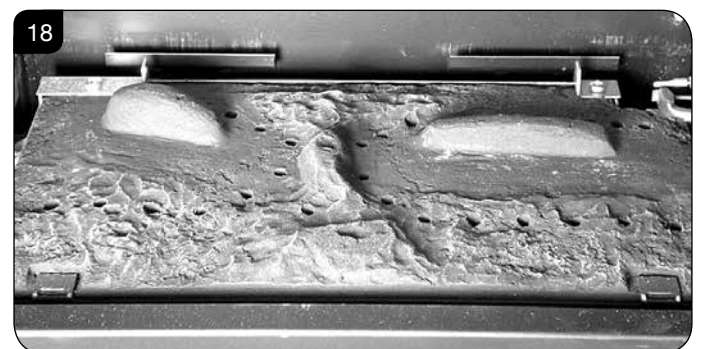

The three logs that make up the fuel bed are visually distinct and fit into specific parts on the burner tray.

# Installation Instructions

- 7.11 Place the rear log into position between the rear brackets and pushed up against the back panel, see Diagram 19.

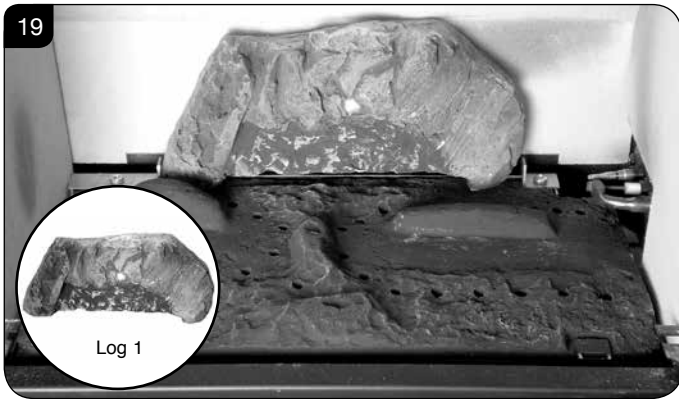

- 7.12 Place the second log into the left hand groove on the burner tray, see Diagram 20. The log should butt up against the raised molding and the left hand side liner.

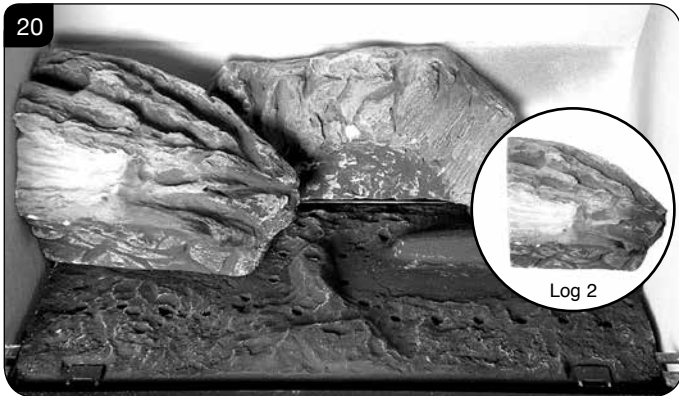

- 7.13 Place the third log into the groove on the right hand side, see Diagram 21. The log should butt up against the raised molding and the right hand side liner.

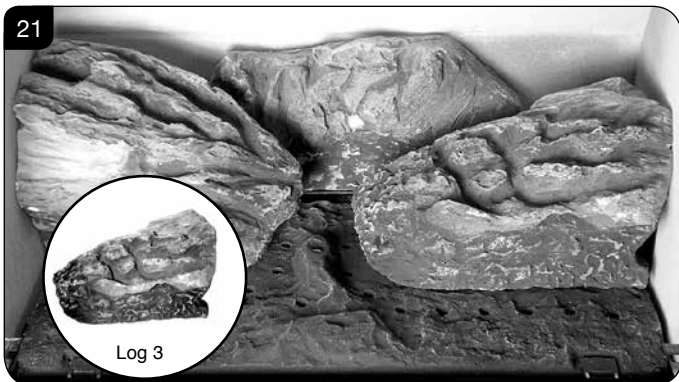

- 7.14 Once the logs are in there are two embers which can be loosely placed at the front of the fuel bed and cover the tabs securing the burner tray, see Diagram 22.

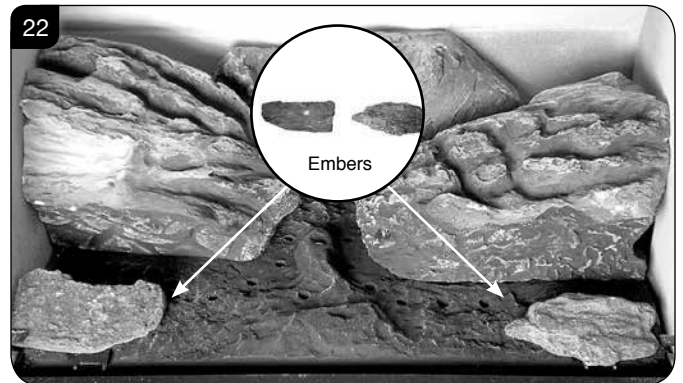

- 7.15 Use some of the Embaglow provided and cover the ports in the burner tray with a liberal amount of fibres, see Diagram 23.

**It is essential to cover the port in the middle of the burner tray in order to get the most visually appealing flame picture.**

NOTE: It is not necessary to use all of the Embaglow.

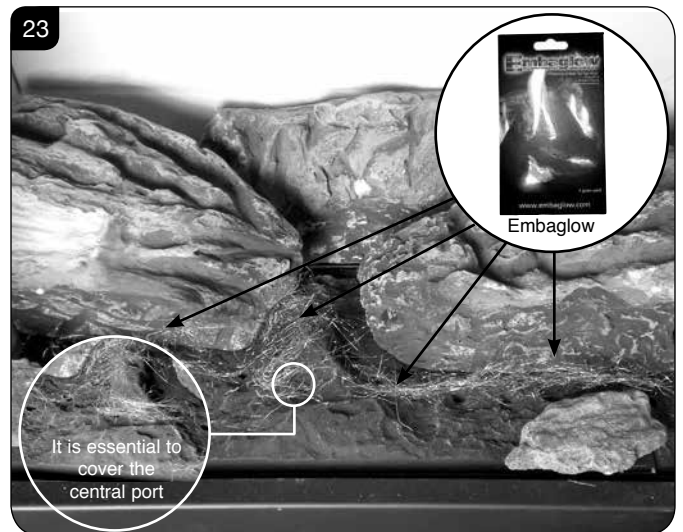

- 7.16 Fix log guard into position, see Diagram 24.

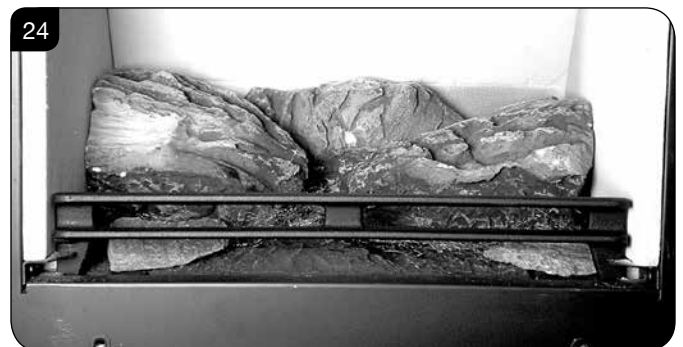

# Installation Instructions

## Huntingdon 40 layout

The logs for the fuel bed are clearly individually labelled, A to D.

- 7.17 Ensure the burner tray is clean and free from any debris, see Diagram 25.

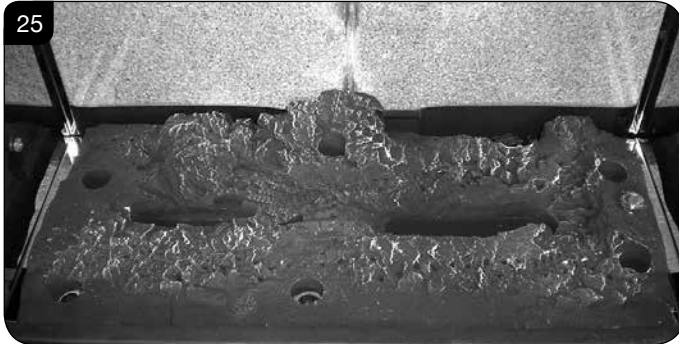

- 7.18 There are 3 embers. Place 2 embers in the back corners of the burner, resting in the cut outs, see Diagram 26. Place the last ember loosely at the front of the fuel bed to cover the hole in the centre.

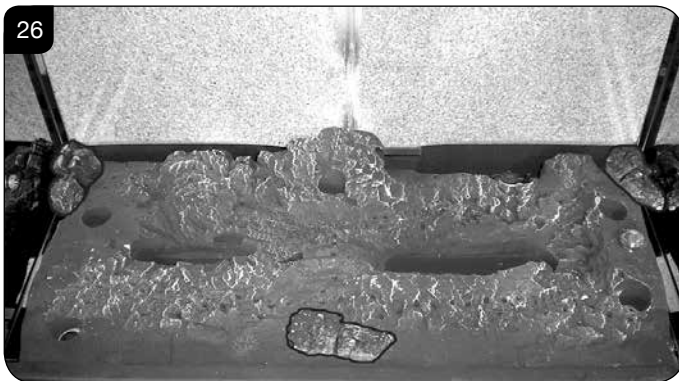

- 7.19 Place Log D on the left hand side of the burner. There is a hole on the underside of Log D which fits over the raised stud on the left of the burner. The back of the log should rest flat against the back panel, see Diagram 27.

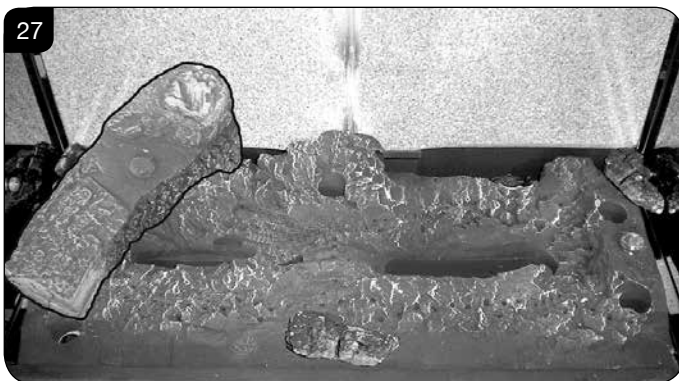

- 7.20 Place Log B on top of Log D. There is a hole on the underside of Log B which fits over the raised stud on Log D to secure in place. The right hand side of the log rests in the groove in the burner, see Diagram 28.

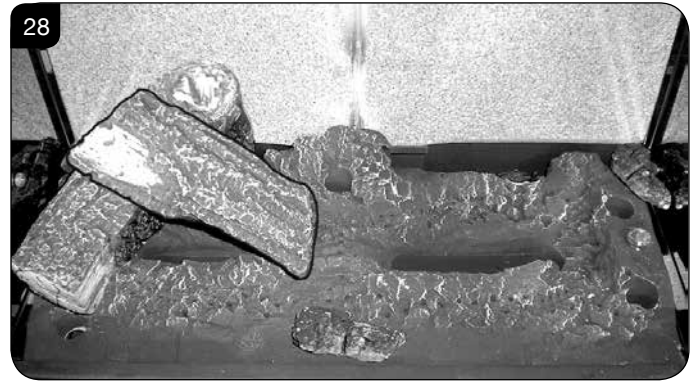

- 7.21 Place Log C on the right hand side of the burner. There is a hole on the underside of Log C which fits over the raised stud on the right of the burner. The back of the log should rest flush against the back panel, see Diagram 29.

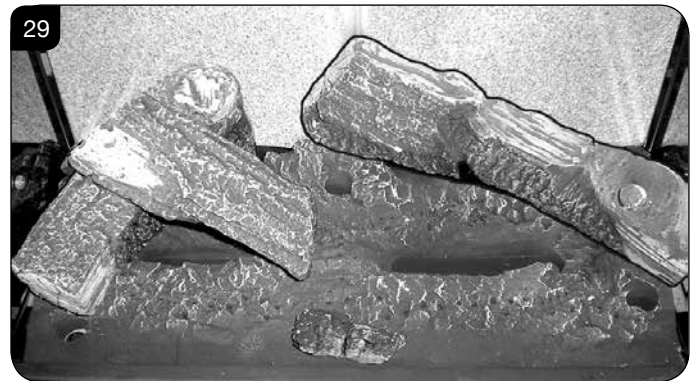

- 7.22 Place the log guard into position on the grooves on the sides of the firebox, see Diagram 30.



# Installation Instructions

- 7.23 Place Log A across Log C. There is a hole on the underside of Log A which fits over the raised stud on Log C to secure in place. The small cut out on the left side of the log rests onto the log guard, see Diagram 31.



- 7.24 Once the logs are in place use some of the Embaglow wire wool provided and cover the ports in the burner tray with a liberal amount of fibres, in the highlighted areas shown in Diagram 32.

**NOTE:** It is not necessary to use all of the Embaglow. **IT IS ESSENTIAL TO KEEP THE REAR PORT FREE FROM OBSTRUCTION**



## 8. Completion of Assembly

- 8.1 Ensure the rope seal fitted to the rear of the glass frame is intact.
- 8.2 Use a ceramic glass product generally sold for cleaning ceramic hobs to clean the glass front.
- 8.3 Refit glass frame and tighten screws evenly, see Diagram 33.

**NEVER OPERATE THE APPLIANCE WHEN THE GLASS FRAME IS REMOVED, OR THE GLASS IS BROKEN.**

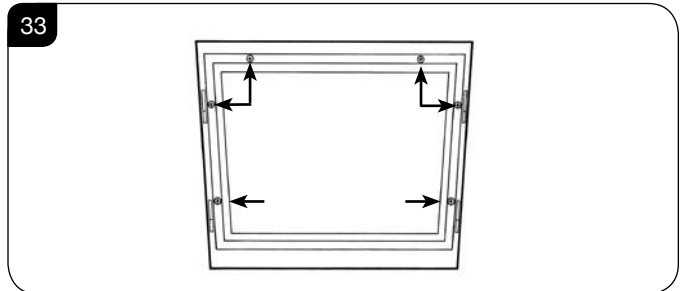

- 8.4 Ensure that the fibreglass seal on the back of the glass frame and replace the screws working from the top down. Tighten the screws evenly **DO NOT OVER TIGHTEN**, see Diagram 33.
- NEVER OPERATE THE APPLIANCE WHEN THE GLASS FRAME IS REMOVED OR BROKEN.**
- 8.5 Replace ALL of the securing screws ensuring that a screw is present in all fixing slots.



**UNDER NO CIRCUMSTANCES SHOULD THE APPLIANCE BE USED IF ANY OF THE GLASS FRAME RETAINING SCREWS ARE LOOSE OR MISSING.**

- 8.6 With the top still supported or removed refit front by locating in grooves and lowering into place, see Diagram 34.

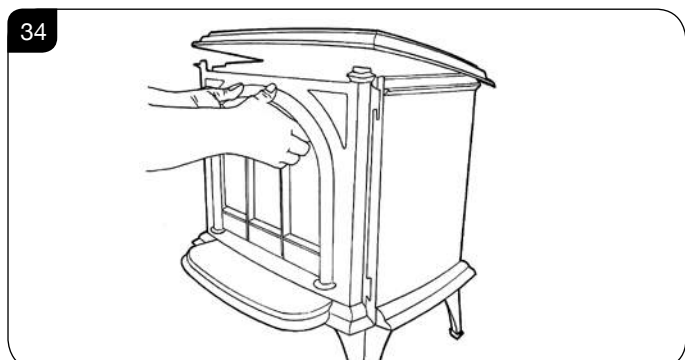



# Installation Instructions

8.7 Now replace top, see Diagram 35.

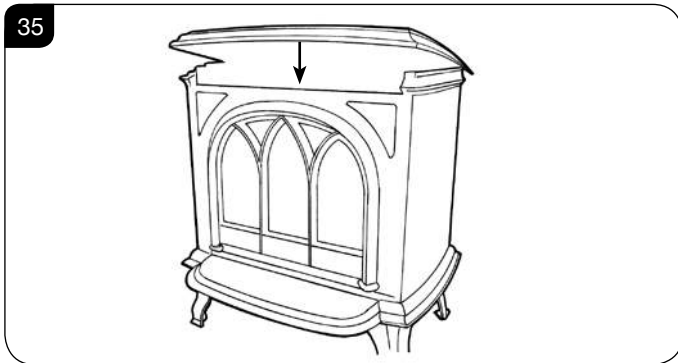

## 9. Operating the Appliance

9.1 The control valve is at the foot on the right-hand side of the appliance. It has two controls, see Diagram 36:

1. The right-hand knob controls the pilot ignition.
2. The left-hand knob controls the main burner.

9.2 Refer to separate instructions if your appliance is upgraded to include battery remote control. The instructions below apply whether or not you have the remote upgrade.

### Lighting the Pilot

9.3 To start the left-hand and right-hand control knobs must both point to off (●):

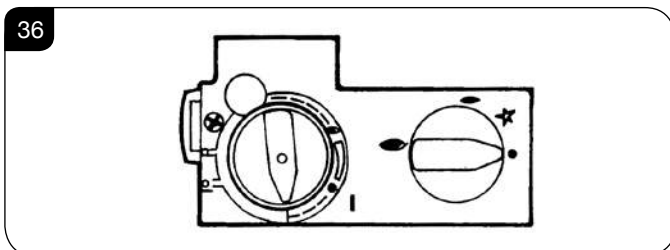

9.4 Press in the right-hand control knob and rotate anti-clockwise until a click is heard. Continue to press in. The knob points to the pilot (←).

The pilot is lit.

9.5 Keep the knob depressed for 10 seconds before releasing. The pilot remains lit.

Repeat the above steps if the pilot does not stay lit.

**NOTE: If the pilot goes out, the Interlock system prevents you lighting again for a short period.**

9.6 If, after repeating the above steps the pilot does not light, contact your Retailer or Installer.

9.7 Turn the right-hand knob to the left to main burner setting (↔).

9.8 Keep the knob depressed for 10 seconds before releasing. The pilot remains lit.

Repeat the above steps if the pilot does not stay lit.

**NOTE: If the pilot goes out, the Interlock system prevents you lighting again for a short period.**

9.9 If, after repeating the above steps the pilot does not light, contact your Retailer or Installer.

9.10 Turn the right-hand knob to the left to main burner setting (↔).

### Adjusting the Flame height

9.11 You can now adjust the flame height and temperature using the left-hand control knob.

9.12 Turn the left-hand knob anti-clockwise to increase the flame height.

9.13 Turn clockwise to decrease the height.



**IMPORTANT: YELLOW FLAMES TYPICALLY APPEAR WHEN THE APPLIANCE HAS REACHED NORMAL OPERATING TEMPERATURE. THIS CAN TAKE UP TO 30 MINUTES.**



**WARNING: IF THE APPLIANCE FAILS TO LIGHT OR BECOMES EXTINGUISHED IN USE, WAIT 3 MINUTES BEFORE ATTEMPTING TO RELIGHT.**

# Commissioning

## 1. Commissioning

- 1.1 Close all doors and windows in the room.
- 1.2 Ignite the appliance and operate on maximum for 10 minutes.
- 1.3 Position a lighted smoke match just inside the draught diverter opening at the rear of the appliance.
- 1.4 Check all smoke is drawn into the opening, see Diagram 1.

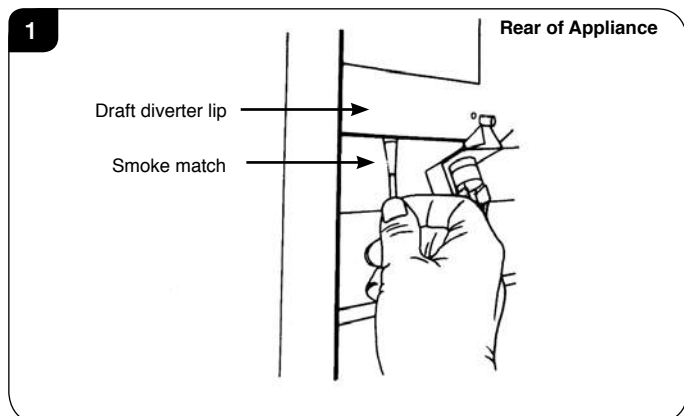

- 1.5 If there is any doubt, run the appliance for a further 10 minutes, and repeat the test.
- 1.6 If there are any extractor fans in adjacent rooms, the test must be repeated with the fans running on maximum and interconnecting doors open.

**IF SPILLAGE PERSISTS, DISCONNECT THE APPLIANCE AND SEEK EXPERT ADVICE.**

- 1.7 Complete the Commissioning Checklist at the front of this manual covering:
  - Flue checks
  - Gas checks
  - Log layout - flame picture
- 1.8 Upon completion of the commissioning and testing of the installation and correct operation of the appliance, the installer must instruct the user how to operate the appliance.
- 1.9 Guide the user through the User Instructions paying particular attention to:
  - a) Regular servicing (Section 13 of the User Instructions).
  - b) Ventilation (Section 14 of the User Instructions) - point out the ventilation positions where applicable.
  - c) Hot surfaces (Section 16 of the User Instructions).

# Servicing Instructions

## Servicing/Fault Finding Charts

### 1. Servicing Requirements

**IMPORTANT** – The glass panel on this appliance should be checked for any signs of damage on the front face of the glass panel (scratches, scores, cracks or other surface defects). If damage is observed, the glass panel must be replaced and the appliance must not be used until a replacement is installed. Under no circumstances should the appliance be used if any damage is observed. Please isolate the appliance until a replacement glass panel has been obtained and installed. Replacement glass panels can be purchased from Gazco via the retailer from which the appliance was purchased or any other Gazco distributor.

This appliance must be serviced at least once a year by a competent person.

All tests must be carried out in accordance with the current GasSafe recommendations.

#### 1.1 Before Testing:

- Conduct a gas soundness test for the property ensuring there are no leaks before servicing.
- Check the operation of the appliance before testing.

#### 1.2 Special checks:

- Clean the burner using a vacuum cleaner with a soft brush attachment. Ensure all debris is removed from the burner ports.
- Clean away lint or fluff from the pilot.
- Clean away lint or fluff from under the burner.
- Check the spark gap on the pilot is correct, see Diagram 1.
- Ensure that the glass frame is secured correctly and that all retaining screws are in place.

1.3 Correct any faults found during the initial test.

1.4 Re-commission the appliance in accordance with Commissioning Procedures.

1.5 Advise the customer of any remedial work undertaken.

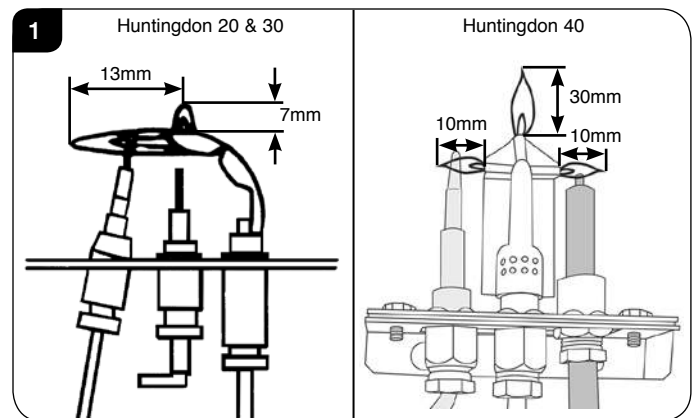

### IGNITION FUNCTIONAL CHECK 1

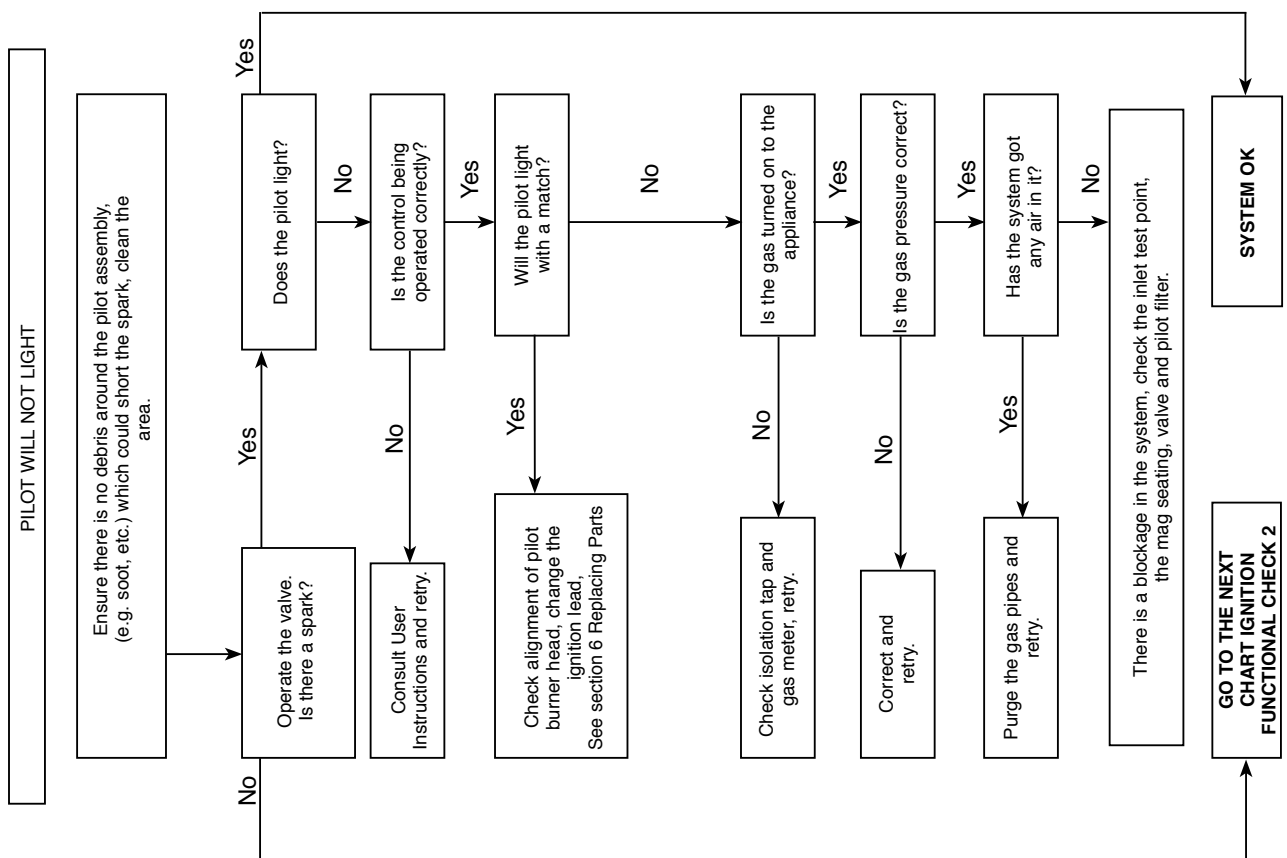

# Servicing Instructions

## Fault Finding Charts

### FLAME FAILURE FUNCTIONAL CHECK 3

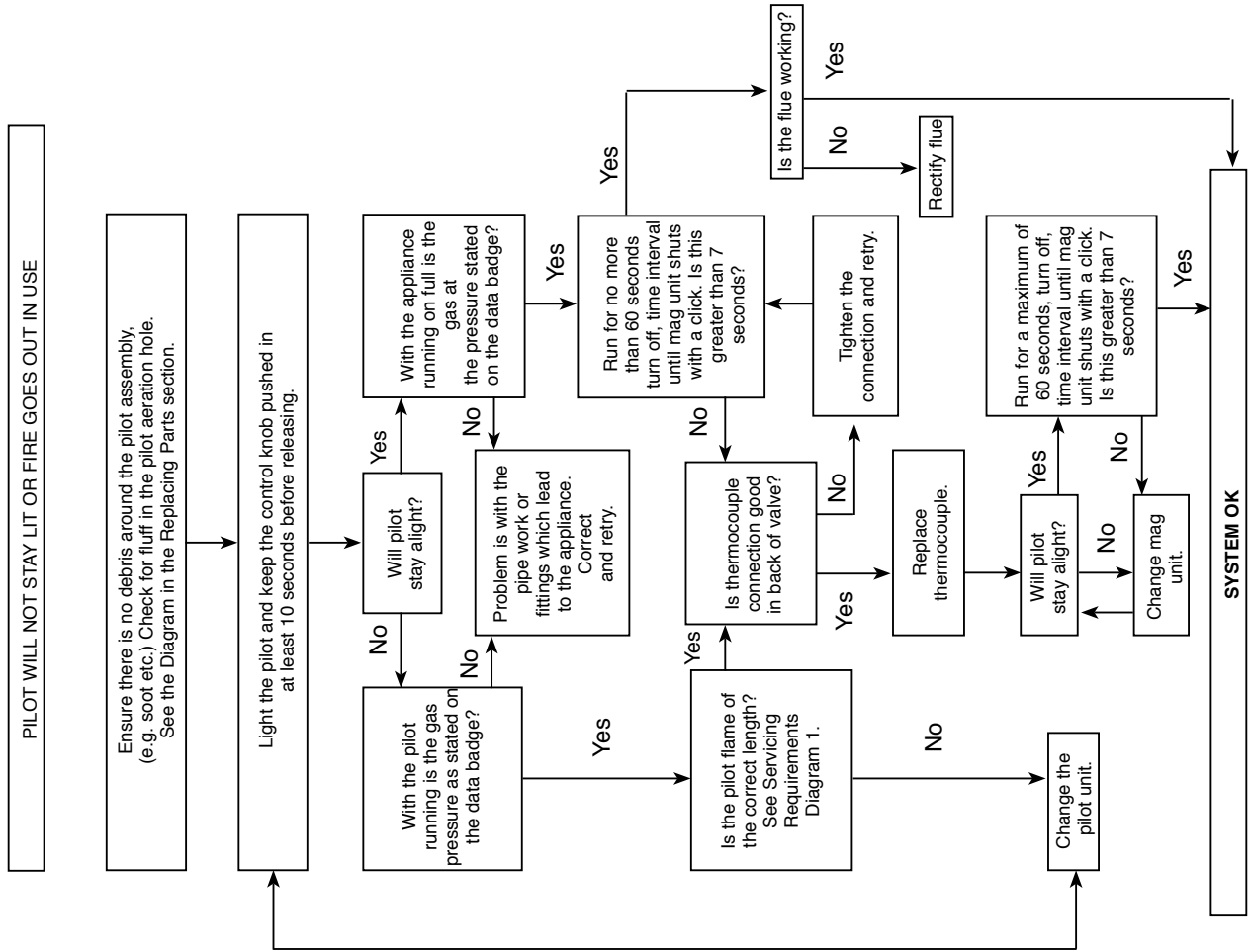

### IGNITION FUNCTIONAL CHECK 2

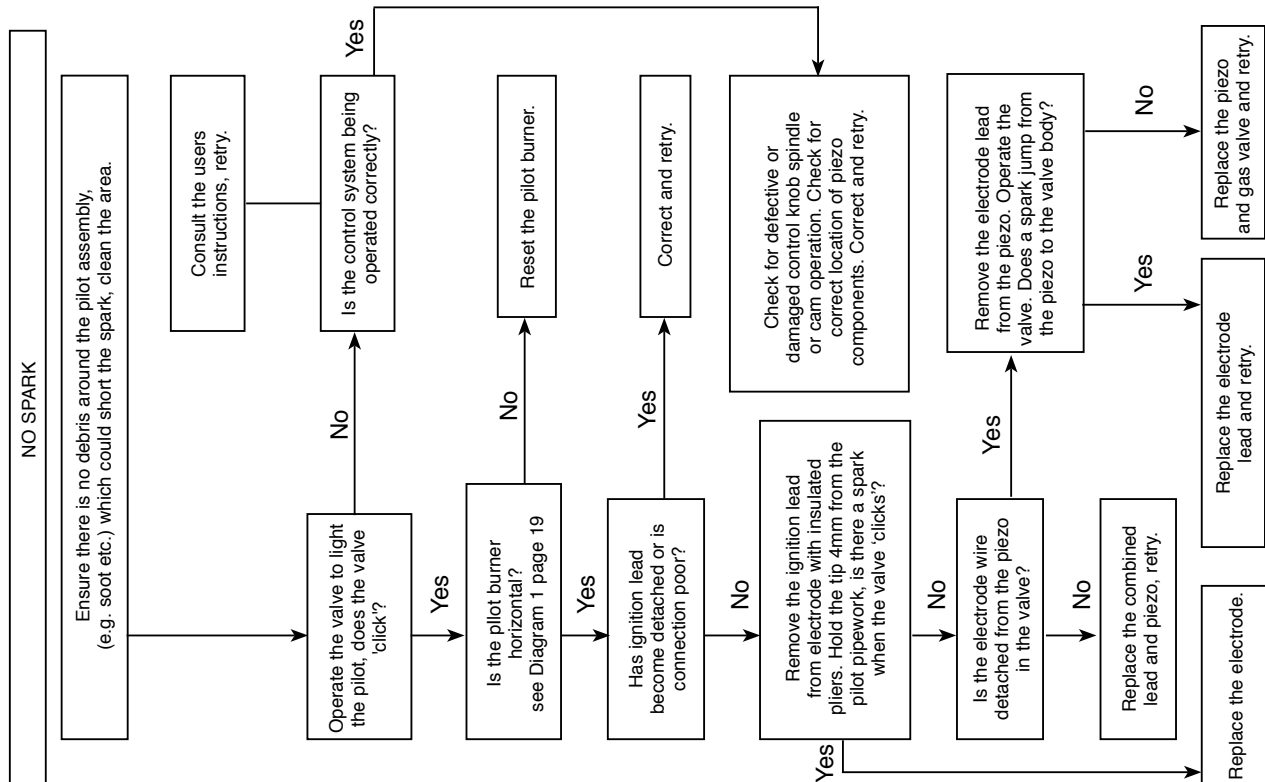

# Servicing Instructions - Replacing Parts

## 1. General



**IMPORTANT: ALWAYS WEAR THE GLOVES PROVIDED WHEN HANDLING AN IVORY PAINTED APPLIANCE.**

- 1.1 All main components can be replaced without removing the appliance from its installation.
- 1.2 Ensure the appliance and surrounds are cool before servicing.

**IT IS ESSENTIAL THAT THE GAS SUPPLY TO THE APPLIANCE IS TURNED OFF AT THE ISOLATION DEVICE BEFORE PROCEEDING FURTHER.**

- 1.3 To service the gas valve and controls the decorative trim can be removed to allow easier access. To do this remove the two screws and gently pull away from the appliance, see Diagram 1.

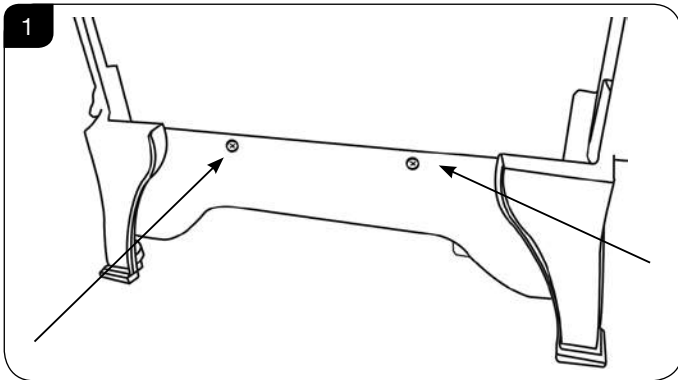

## 2. Removing the Door



**IMPORTANT: THE OUTER PANNELLING OF THE APPLIANCE IS MADE FROM CAST IRON. USE CAUTION WHEN INSTALLING, REMOVING AND STORING AS THE COMPONENTS ARE HEAVY AND SHOULD BE HANDLED CAREFULLY.**

- 2.1 For rear flue exit lift the top of the appliance off and put to one side.
- 2.2 For top flue exit lift and support the top to give clearance, see Diagram 2.

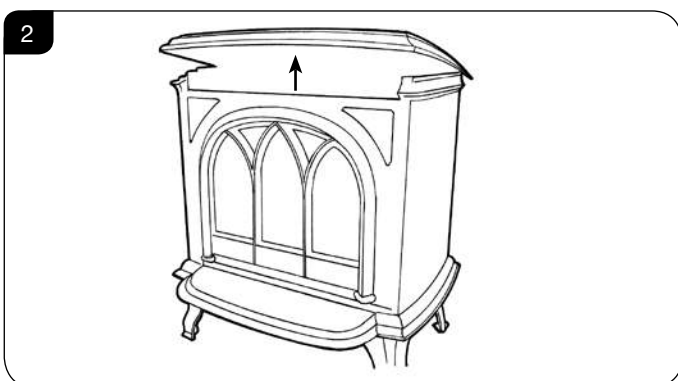

## Huntingdon 20 and 40

- 2.3 Lift the front upwards until it is clear of the slots and pull away from the appliance, see Diagram 3.

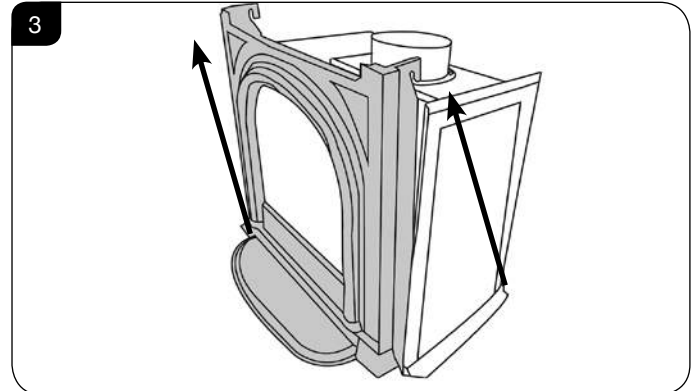

## Huntingdon 30

- 2.4 Lift the front upwards until it is clear of the slots and pull away from the appliance, see Diagram 4.

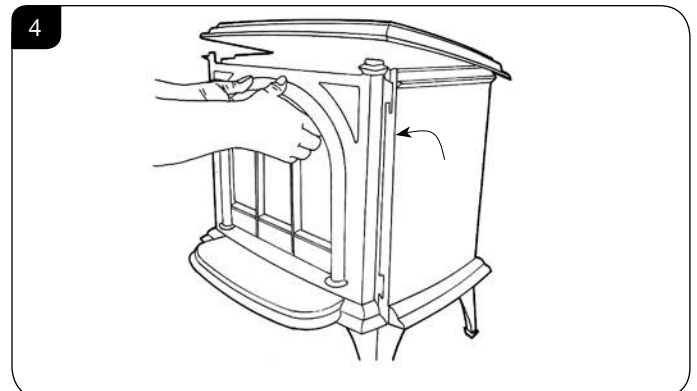

## 3. Window Frame Assembly

### All Models

- 3.1 Remove the glass frame by undoing the fixing screws and lifting clear, see Diagram 5. **Take care to support the glass window panel when removing the screws.**

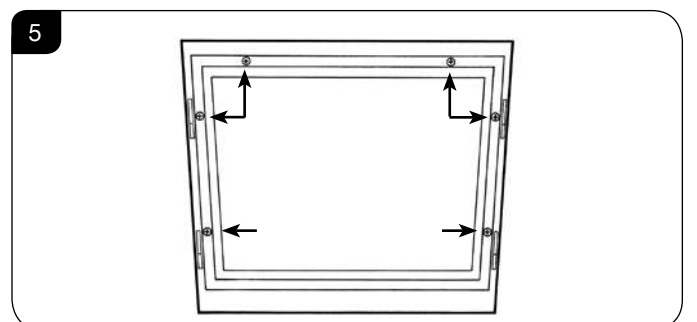

# Servicing Instructions - Replacing Parts

- 3.2 Place carefully to one side.
- 3.3 Lift out the log retainer and carefully remove the ceramic fuel bed components
- 3.4 Refit in reverse order.
- 3.5 Ensure that the fibreglass seal on the back of the glass frame and replace the screws working from the top down. Tighten the screws evenly **DO NOT OVER TIGHTEN**, see Diagram 3.

**NEVER OPERATE THE APPLIANCE WHEN THE GLASS FRAME IS REMOVED OR BROKEN.**

- 3.6 Replace ALL of the securing screws ensuring that a screw is present in all fixing slots.



**UNDER NO CIRCUMSTANCES SHOULD THE APPLIANCE BE USED IF ANY OF THE GLASS FRAME RETAINING SCREWS ARE LOOSE OR MISSING.**

## 4. Baffle & Ceramic Liners

- 4.1 To access the burner tray and interior workings of the appliance it may be necessary to remove the baffle and the liners.

### 4a. Liners (Huntingdon 20 only)

#### BAFFLE

- 4.2 There is no requirement to remove the baffle for servicing.

#### LINERS

- 4.3 The burner can be accessed without the need to remove the side liner panels. If they need to be taken out then first remove the screws securing the two brackets on either side of the firebox. The panels will now slide forward, see Diagram 6.

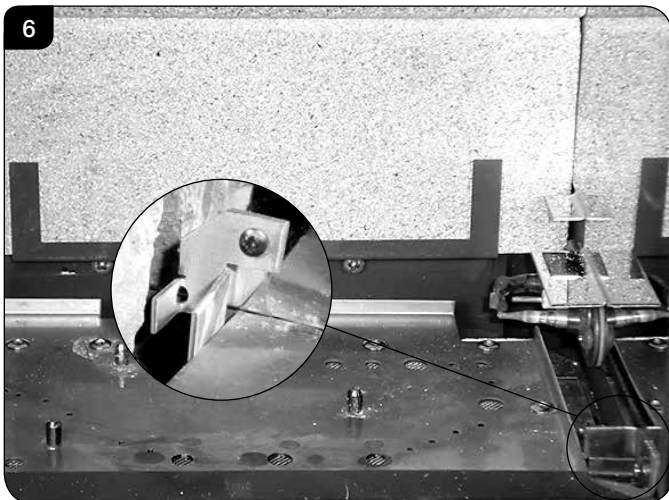

- 4.4 Gently lift the upper rear liner and pull forwards. With the panel raised it should be possible to remove from the liner brackets, see Diagram 7.  
Note: It may be necessary to use a flat object like a screwdriver to separate the two panels.

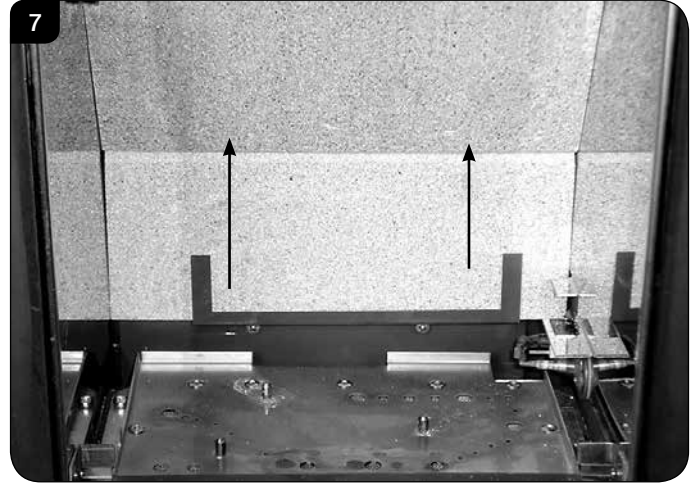

- 4.5 Slide the lower rear liner up and out of the lower bracket, see Diagram 8.

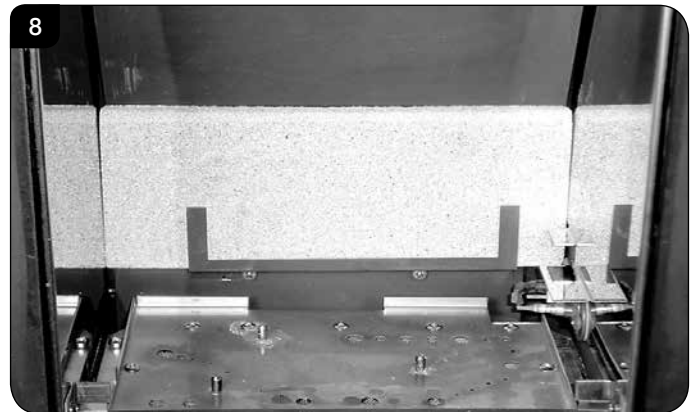

- 4.6 Replace all parts in reverse order ensuring the cutouts in the rear of the lower panel fit over the screws on the back of the firebox, see Diagram 9.

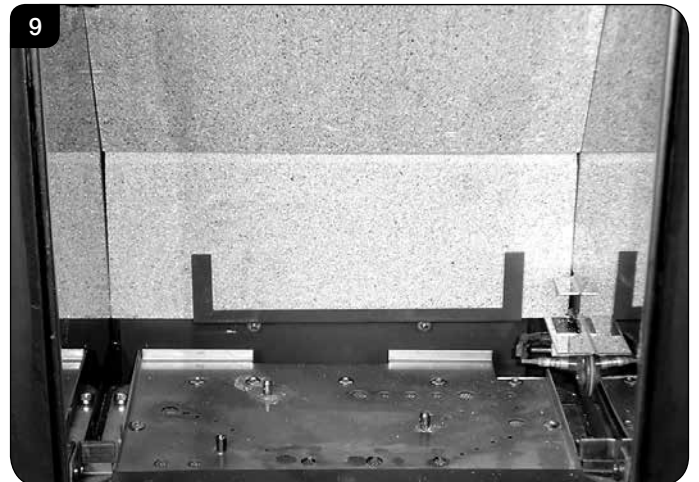

# Servicing Instructions - Replacing Parts

## 4b. Baffle & Liners (Huntingdon 30 only)

### BAFFLE

- 4.7 The baffle must be removed before the liners can be taken out of the appliance.

To do this undo the two screws securing it to the roof of the firebox, see Diagram 10.

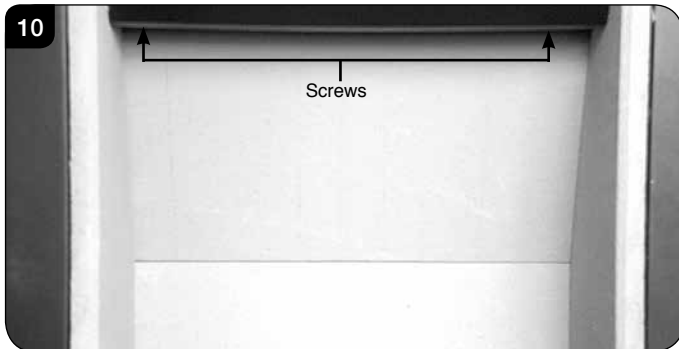

- 4.8 The baffle can now be removed through the front of the appliance.

### CERAMIC LINERS

Once the baffle has been placed carefully to one side the liners can then be taken out in the following order.

- 4.9 To remove the Left Hand liner first tilt inwards towards the centre of the firebox before lifting up and pulling out through the front of the firebox, see Diagram 11.

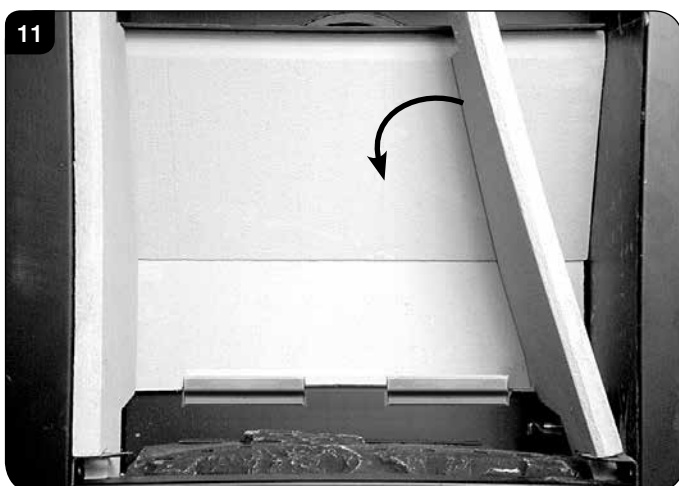

- 4.10 To remove the Right Hand liner first tilt inwards towards the centre of the firebox before lifting up and pulling out through the front of the firebox, see Diagram 11.

The two side liners also support the raised rear liner. Taking out the side liners will allow the rear liner to drop down so ensure it is supported and removed carefully, see Diagram 12.



- 4.11 The lower rear liner does not need to be removed from the bracket in order to access the burner tray for maintenance, but can be lifted off in order to clean or replace, see Diagram 13.

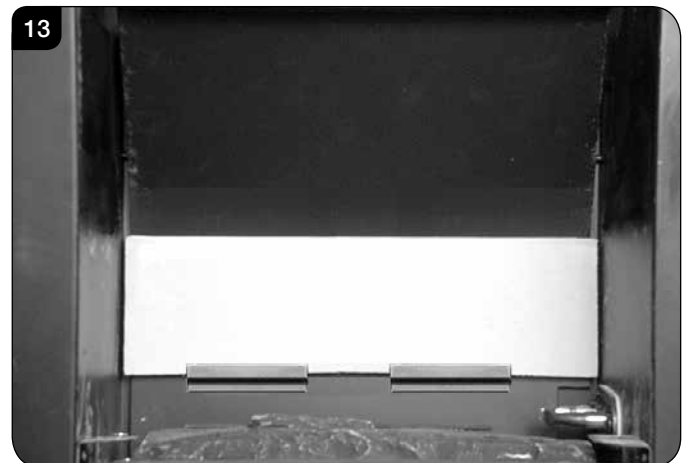

# Servicing Instructions - Replacing Parts

4.12 With the liners and baffle removed the firebox is clear for cleaning and maintenance, see Diagram 14.

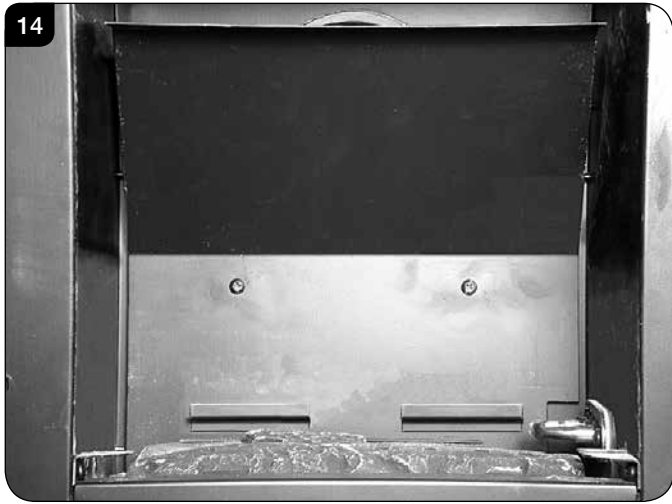

4.13 To replace the liners liner and baffle reverse these procedures.

## 4c. Baffle & Liners (Huntingdon 40 only)

4.14 To access the burner tray and interior workings of the appliance it may be necessary to remove the baffles and the liners.

4.15 This appliance has 2 baffles, 1 metal and 1 vermiculite, that must be removed before the liners can be taken out of the appliance.

4.16 Remove the logs.

### METAL BAFFLE

To remove the metal baffle:

4.17 Undo the 3 screws securing it to the roof of the firebox, see Diagram 15.

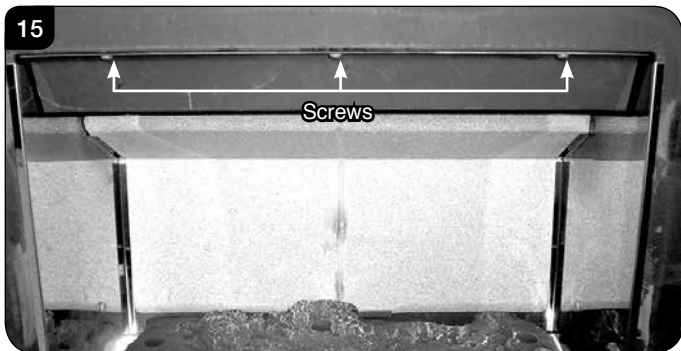

4.18 The baffle can now be removed through the front of the appliance.

### VERMICULITE BAFFLE

To remove the vermiculite baffle:

4.19 Lift the vermiculite baffle and slide out through the front of the appliance, see Diagram 16.

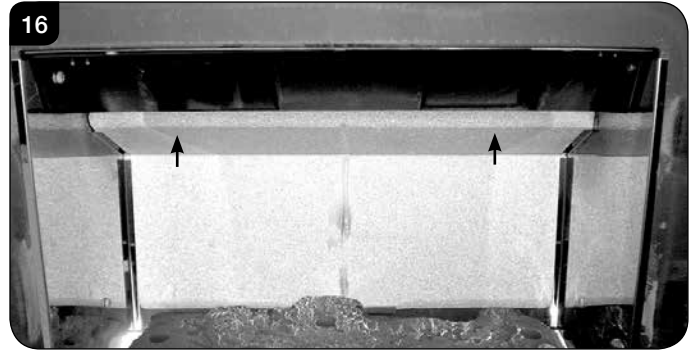

Once the baffles have been placed carefully to one side the liners can then be taken out in the following order.

### REFLECTIVE LINERS

4.20 To remove the left hand liner undo the 3 screws, including the 1 under the log guard bracket, see Diagram 17.

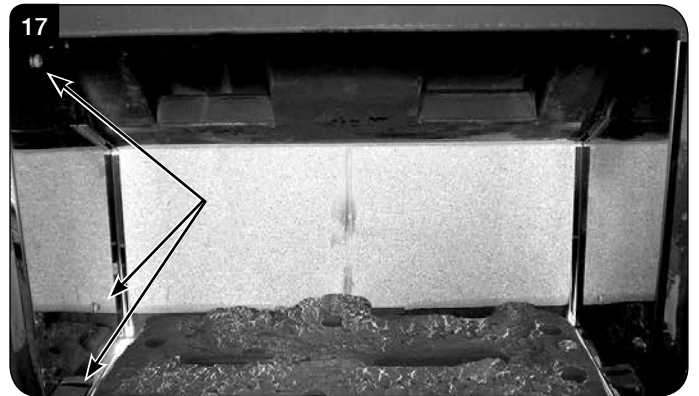

4.21 Remove the log guard bracket.

4.22 Tilt the liner inwards towards the centre of the firebox before lifting up and pulling out through the front of the firebox, see Diagram 18.

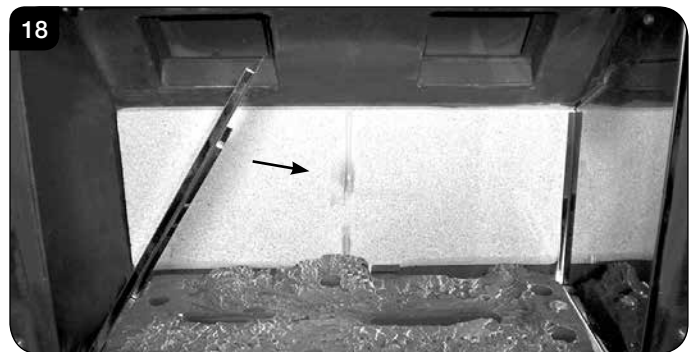

4.23 To remove the right hand liner undo the 3 screws, including the 1 under the log guard bracket, see Diagram 17.

4.24 Remove the log guard bracket.



# Servicing Instructions - Replacing Parts

- 4.25 Tilt the liner inwards towards the centre of the firebox before lifting up and pulling out through the front of the firebox, see Diagram 18.

## VERMICULITE LINER

- 4.26 The rear liner does not need to be removed in order to access the burner tray for maintenance, however it is advisable to remove the rear panel to avoid possible damage and to clean or replace.
- 4.27 To remove the back panel lift out of the bracket and remove through the front of the appliance, see Diagram 19.

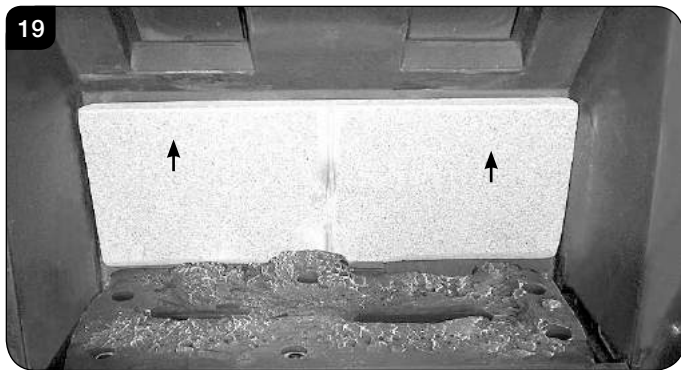

- 4.28 With the liners and baffle removed the firebox is clear for cleaning and maintenance, see Diagram 20.

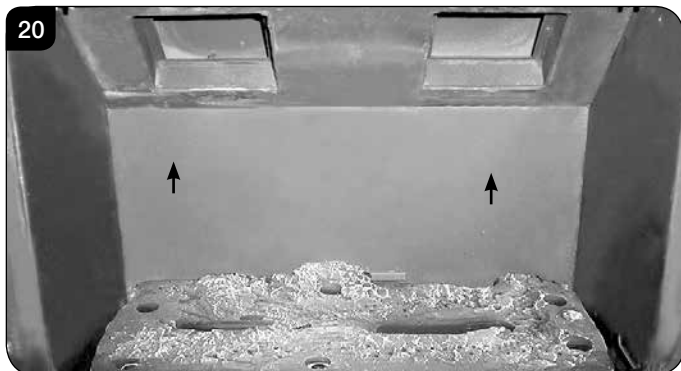

## 5. Main Burner

- 5.1 To replace the main burner:

Remove the baffle and liners, see Section 4.

- 5.2 Remove the three securing screws from the edges of the burner, see Diagram 21.

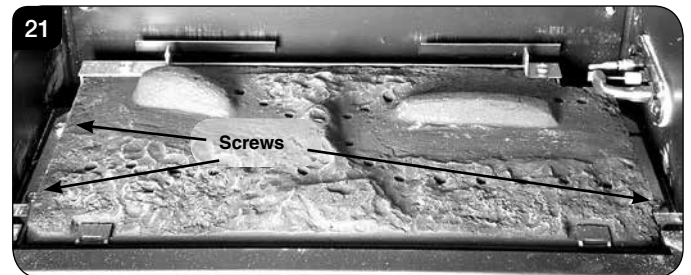

- 5.3 Slide the burner fully to the right whilst lifting the Left Hand side clear of the bracket, see Diagram 22.

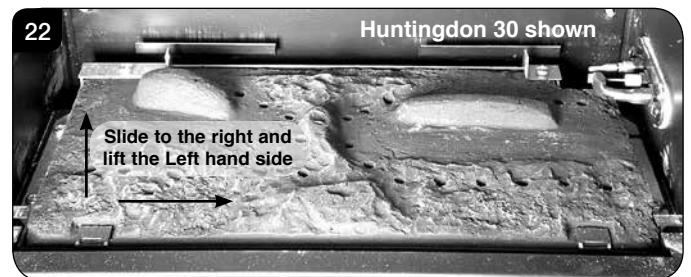

- 5.4 Slide the burner back to the left and out of its location.  
**IMPORTANT: Take care when removing the burner not to damage the ceramic pad with the pilot unit attached.**

Refit in reverse order

# Servicing Instructions - Replacing Parts

## 6. Pilot Unit

### Huntingdon 20 & 30 Only

6.1 The pilot assembly consists of five components, which can be individually replaced:

Pilot burner bracket  
Pilot injector  
Electrode  
Thermocouple  
Gasket

6.2 Turn the gas supply off at the isolation device, remove the door and place to one side, carefully remove the ceramic fuel bed components.

### 6a. Pilot Burner Bracket

6.3 Remove the two fixing screws from the pilot bracket, see Diagram 22. Gently draw the assemble away from the firebox to give access to the nuts and ignition lead.  
**NOTE: TAKE CARE NOT TO DAMAGE THE GASKET.**

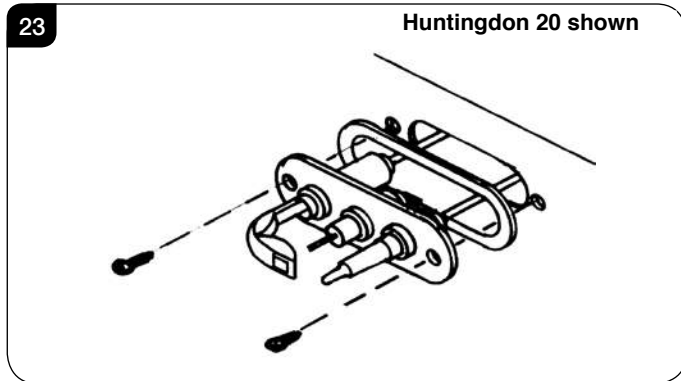

### 6b. Pilot Injector

6.4 Undo the compression nut on the pilot feed pipe and withdraw the injector which will be hooked onto the olive. When replacing an injector always make sure it is hooked onto the olive before inserting it into the pilot burner, see Diagram 24.

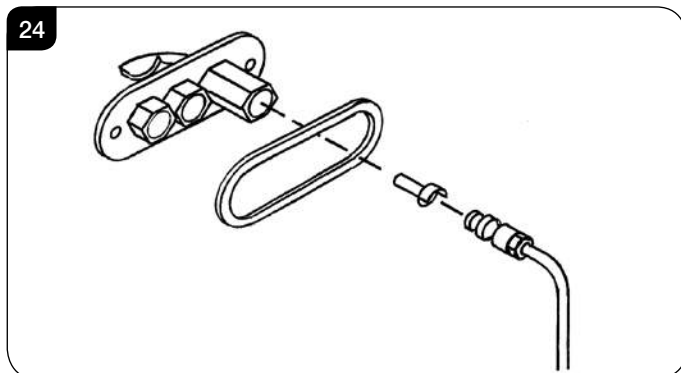

### 6c. Electrode

6.5 Disconnect the ignition lead and undo the retaining nut. The electrode can now be removed, note the orientation of the electrode terminal when reassembling, see Diagram 25.

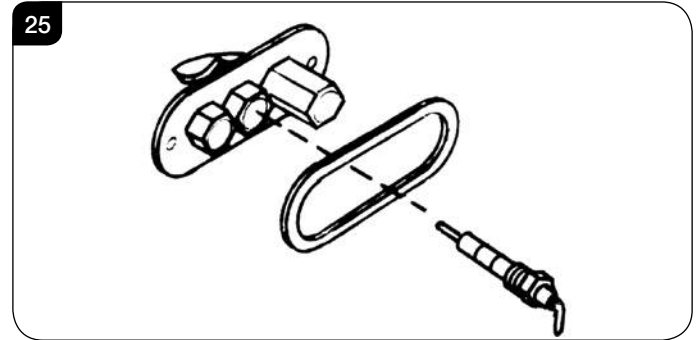

### 6d. Thermocouple

6.6 Undo the retaining nut and withdraw the thermocouple. Undo the thermocouple from the back of the gas valve, see Diagram 26. Reassemble in reverse order. Do not overtighten.

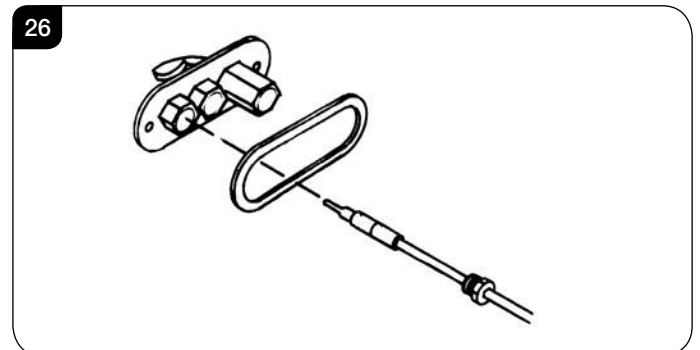

### 6e. Gasket

6.7 Disconnect all the above components and withdraw the gasket. If it is damaged, replace with a new item. Always replace the gasket first when reassembling the pilot components.

# Servicing Instructions - Replacing Parts

## Huntingdon 40 Only

The pilot assembly consists of 4 components which can be individually changed:

- Pilot burner bracket
- Electrode
- Pilot injector
- Thermocouple

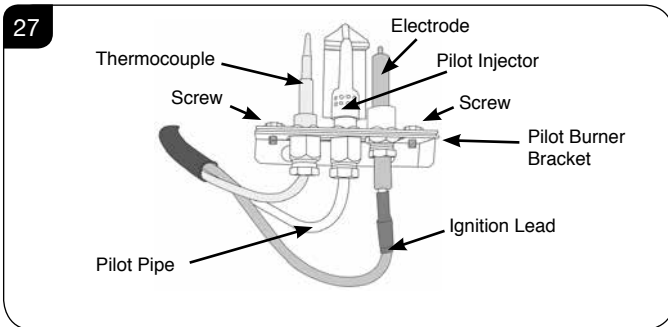

**NOTE: Ensure the sealant surrounding the Electrode and Thermocouple leads is replaced if disturbed or removed whilst gaining access to these components.**

- 6.8 Turn the gas supply off at the isolation device, remove the door and place to one side, carefully remove the ceramic fuel bed components.

## Pilot Burner Bracket

To remove the Pilot Burner Bracket:

- 6.9 **First remove the electrode, pilot pipe and thermocouple as described in the following sections.**
- 6.10 Remove the 2 screws securing the bracket. The pilot burner bracket can now be removed.
- 6.11 Replace in reverse order.

## Electrode

- 6.12 Pull the ignition lead off the electrode and undo the retaining nut, see Diagram 27.
- 6.13 Replace with a new electrode. Do not over-tighten the nut; this could break the component.
- 6.14 Replace the ignition lead by pushing the spade connector onto the terminal (electrode).

## Pilot Injector

- 6.15 Undo the pilot pipe from the gas valve and from the underside of the pilot burner, see Diagram 27.
- 6.16 Remove the pipe and the injector drops out from the burner.

## Thermocouple

- 6.17 Disconnect the thermocouple from the gas valve.
- 6.18 Undo the thermocouple nut in the back of the pilot bracket half a turn. This releases the thermocouple.
- 6.19 When replacing with a new thermocouple, take care to bend the new component to the same shape as the thermocouple just removed.
- 6.20 To refit the thermocouple into the pilot bracket, ensure it is pushed fully into the hole. There is a stop on the thermocouple to set the height.
- 6.21 Lock the retaining nut just enough to grip the thermocouple.
- 6.22 Connect the thermocouple to the valve **taking care not to over-tighten.**

## 7. Ignition Lead

- 7.1 Follow the Pilot Unit instruction to access the back of the pilot assembly.
- 7.2 Disconnect the ignition lead from the electrode.
- 7.3 Remove the front cover from the control valve by removing the retaining screw, see Diagram 28 and gently levering clear with flat bladed screwdriver, see Diagram 29.

**NOTE: There is a small cylindrical metal spacer inside the cover, this must be kept and replaced on the fixing screw on re-assembly.**

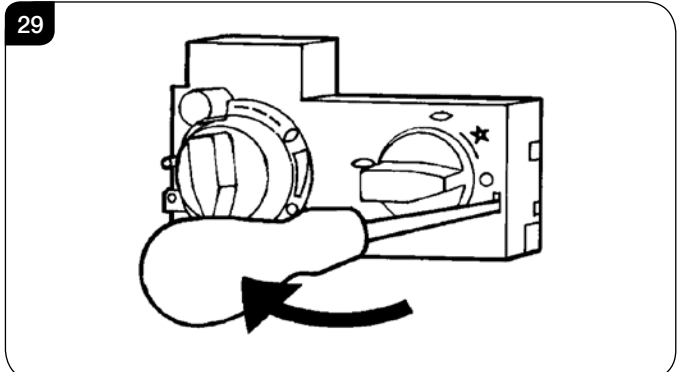
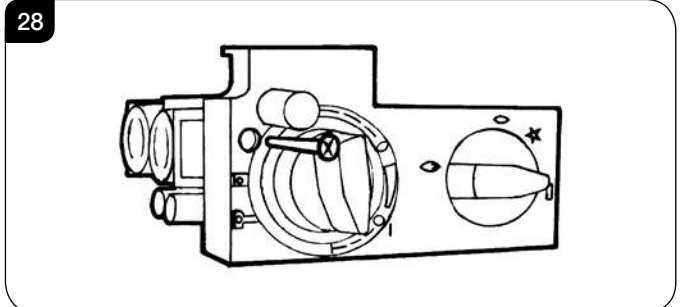

- 7.4 Disconnect the other end of the ignition lead from the valve body noting the route of the ignition lead.

# Servicing Instructions - Replacing Parts

- 7.5 Replace with a new ignition lead following the same route as the old one.

Replace the valve cover and the pilot assembly.

- 7.6 Check operation of the new ignition lead.

## 8. Piezo

- 8.1 The piezo assembly used on this appliance is not serviceable and is unlikely to fail.
- 8.2 If a new piezo is required it will be necessary to change the valve, see Section 9.

## 9. Gas Valve

- 9.1 To remove the valve turn off the gas supply at the isolation device.
- 9.2 Disconnect the 2 x 8mm and 1 x 4mm gas pipe fittings at the back of the gas valve, see Diagram 30 (A).
- 9.3 Disconnect the thermocouple, see Diagram 30 (B).

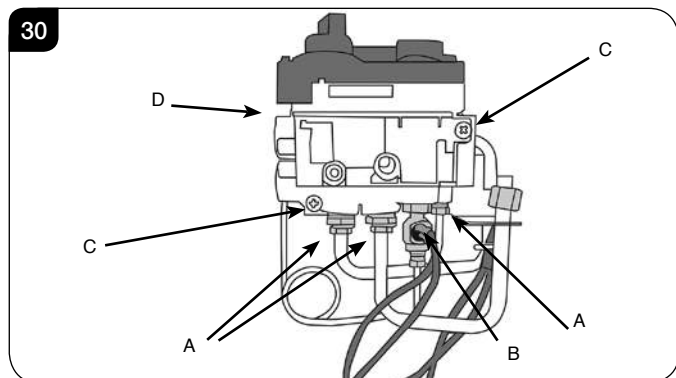

- 9.4 Disconnect the ignition lead from the gas valve, see Diagram 30 (D).
- 9.5 Remove the cover, see Section 7.3.
- 9.6 Undo the two bolts securing the gas valve to the appliance and remove the valve, see Diagram 30 (C).
- 9.7 Replace in reverse order.
- 9.8 Check all joints for gas leaks and check operation of the thermocouple and ignition lead.

## 10. Magnetic Safety Valve

- 10.1 Turn the gas supply off at the isolation device.
- 10.2 Undo the thermocouple connection from the back of the gas valve, see Diagram 31 (A).
- 10.3 Pull the sensor leads clear and remove the interruptor block, see Diagram 31 (B).
- 10.4 Undo the magnetic valve-retaining nut from the back of the control valve, see Diagram 31 (C).

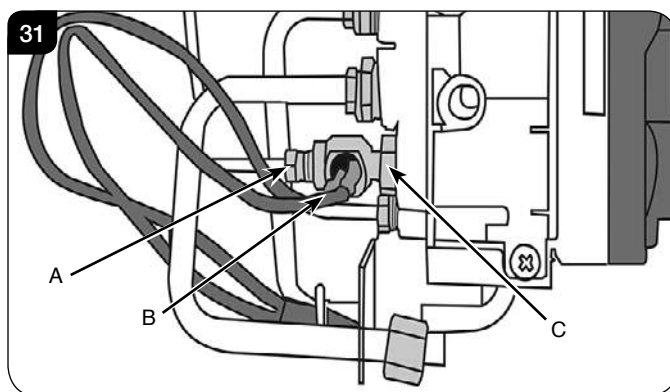

- 10.5 Gently tap out the magnetic valve and replace with a new unit.
- 10.6 Replace the retaining nut and tighten.
- 10.7 Reassemble the interruptor block and leads and secure the thermocouple connection in the rear of the gas control. (Do not overtighten: For best results make sure the nut is finger tight and then give an additional 1/4 turn with a spanner.)
- 10.8 Turn the gas supply on and check the entire pipework and valve joints for any leaks.

## 11. Main Injector

- 11.1 To remove the main injector turn off the gas supply at the isolation device.
- 11.2 Remove the main burner, see Section 5.
- 11.3 Undo the compression nuts from the feed pipe and the gas valve under the appliance.
- 11.4 Working from inside the firebox remove the lock nut from the injector, see Diagram 32.

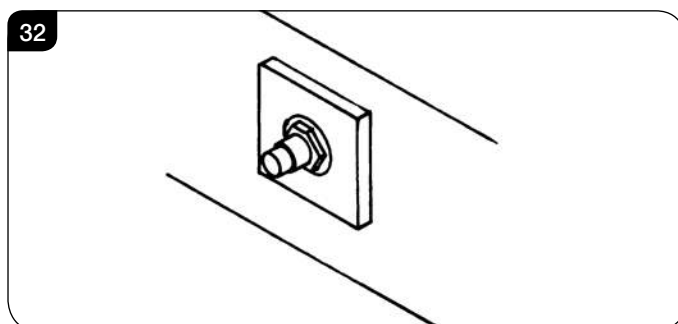

# Servicing Instructions - Replacing Parts

- 11.5 Extract the injector with the feed pipe from beneath the appliance.
- 11.6 Holding the injector with a spanner:
- 11.7 Undo the feed pipe. **Note the orientation of the Injector.**
- 11.8 Re-assemble in reverse order.
- 11.9 Turn on the gas supply and check for leaks.

## 12. Flue Sure System

- 12.1 Open the door and remove the ceramics, placing them carefully to one side.
- 12.2 Remove all the liner panels, the log support bracket and main burner.

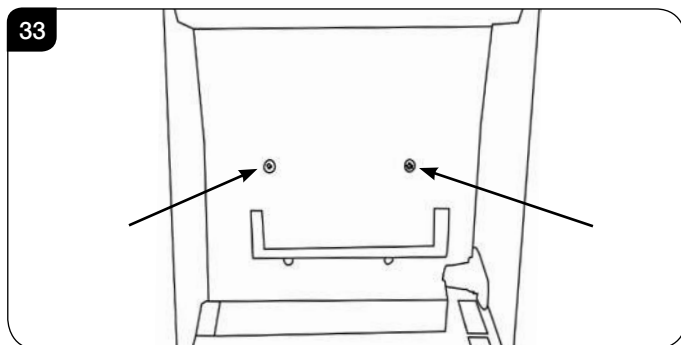

- 12.3 Remove the two screws securing the metal panel at the rear of the firebox, see Diagram 34.

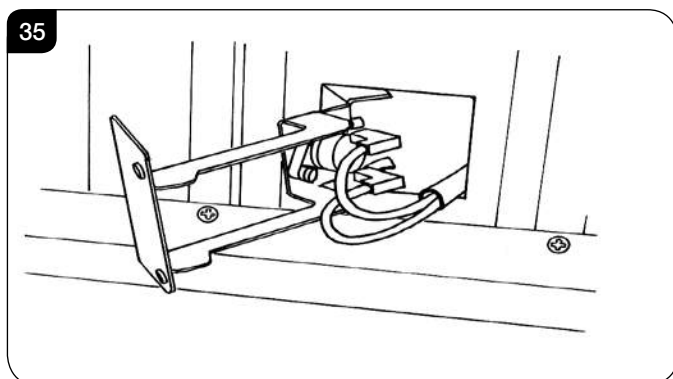
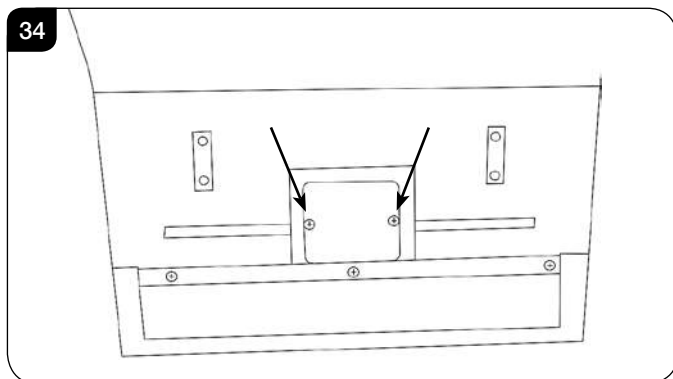

- 12.4 Disconnect the two sensor wires.
- 12.5 Undo the two retaining screws.
- 12.6 Remove the sensor and the two plastic spacers, see Diagram 36 (Huntingdon 30 only).

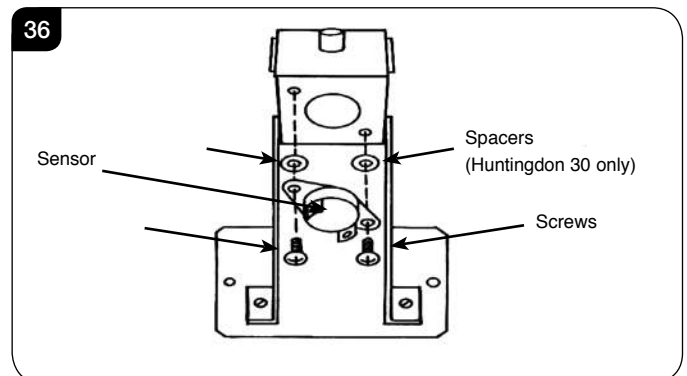

- 12.7 Refit the new sensor ensuring the plastic spacers are located between the bracket and the sensor.
- 12.8 Refit the leads.
- 12.9 Feed the cable back through the hole as you replace the bracket.  
When the bracket is located correctly it sits flush with the back panel without force. If not positioned correctly the bracket sits at an angle, see Diagram 37.

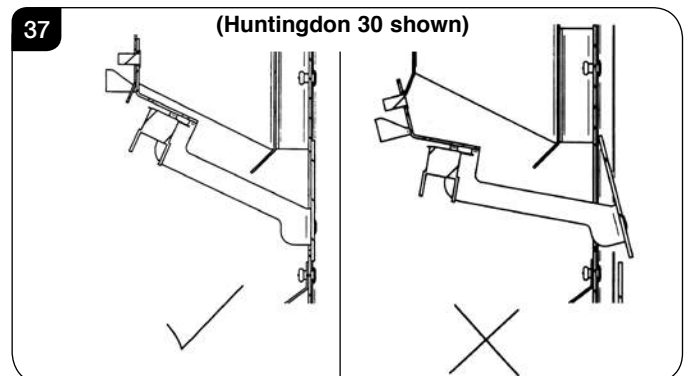

- 12.10 Replace the metal panel. There are spacers on the top edge to ensure the correct distance from the baffle. These interlock with the rear of the baffle, see Diagram 38.

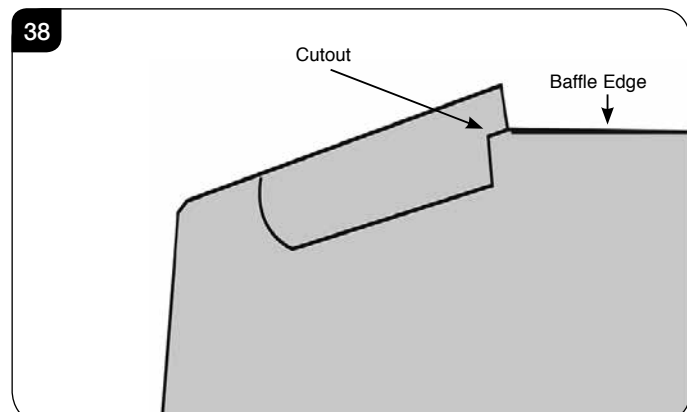

- 12.11 Replace remaining components in reverse order.

# Servicing Instructions - Replacing Parts

## 13. Primary Aeration Plate

**NOTE: Not all models have aeration plates. Please refer to the Technical Specification.**

- 13.1 To replace the primary aeration plate turn off the gas supply at the isolation device.
- 13.2 Remove the burner, as described in Installation Instructions, Replacing Parts, Section 5.

### Huntingdon 20 & 30

- 13.3 Remove the fixing screw and slide the plate off the venturi.
- 13.4 Replace with the correct size plate and secure with the screw. Ensure the lower edge of the plate is located over the venturi flange, see Diagram 39.

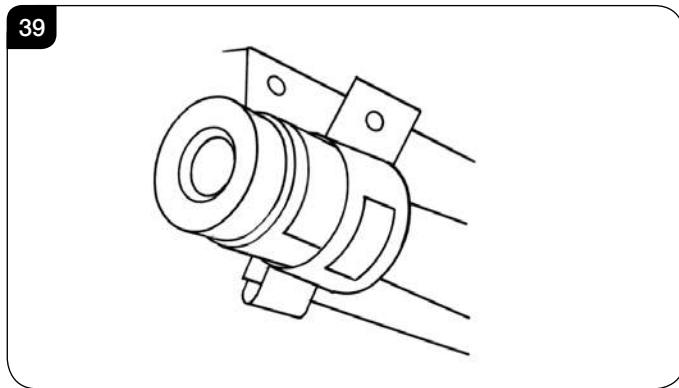

- 13.5 Reassemble in reverse order.  
**NOTE: Even if no aeration plate is required, the small screw must be replaced.**

### Huntingdon 40

- 13.6 Remove the fixing nuts and slide the plate off the venturi.
- 13.7 Replace with the correct size plate and secure with the nuts. Ensure the lower edge of the plate is located over the venturi flange, see Diagram 40.

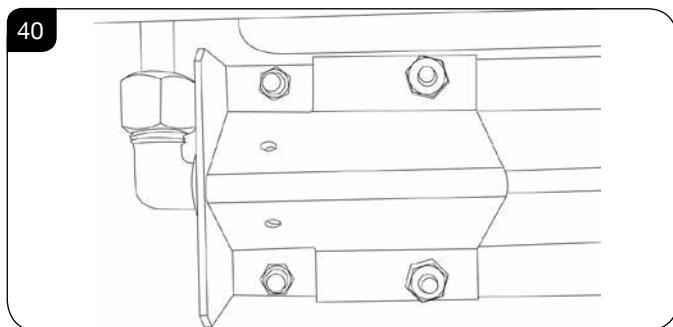

- 13.8 Reassemble in reverse order.

## 14. Changing Between Gas Types

A kit of parts is available for this - Contact your Gazco retailer for further information.

Always quote the Model number and Serial number when ordering any spare parts.

## 15. Control Upgrade

See Installation Instructions, Section 2.

# Servicing Instructions - Replacing Parts

## 16. Spare Parts List - Huntingdon 20

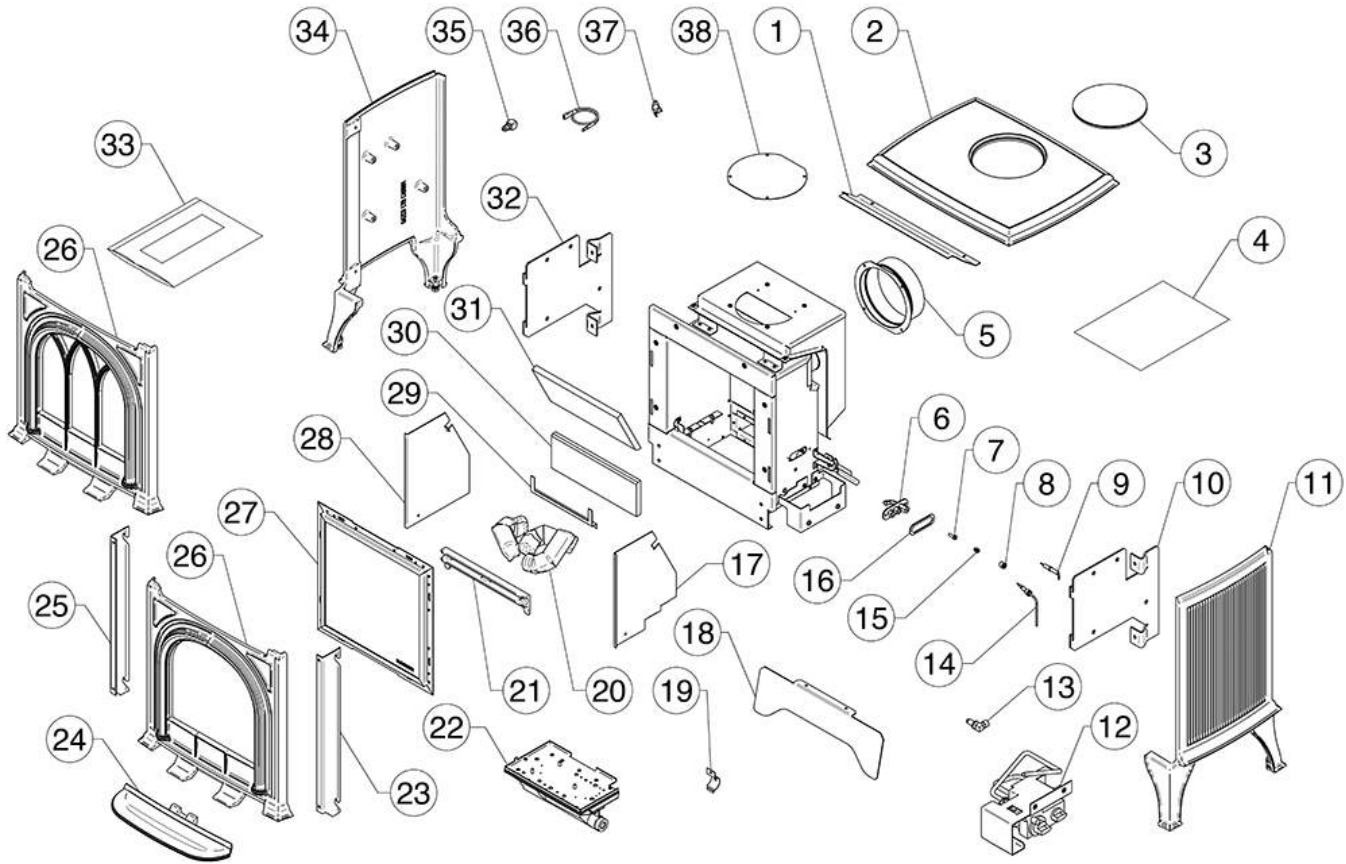

No.	Component	Part Code		
		Natural Gas	LPG	Quantity
1	Top Vanity Cover	GZ12528		1
2	Top Casting	CA0804*		1
3	Blanking Plate	CA0720*		1
4	Instruction Manual	PR1811		1
5	Spigot	MEC0033		1
6	Pilot Burner Bracket	PI0051		1
7	Pilot Burner Injector	PI0026	PI0015	1
8	Hook Nut	PI0014		1
9	Electrode	PI0053		1
10	RH Engine Mount	GZ12525		1
11	RH Side Casting	CA0800*		1
12	Control Assembly	B0213		1
13	Elbow Injector	IN0040 - Size 185	IN0071 - Size 90	1
14	Thermocouple	PI0010		1
15	Hook Olive	PI0013		1
16	Pilot Burner Gasket	PI0052		1
17	RH Reflector	GZ12827		1
18	Vanity Cover	GZ12529		1
19	Aeration Plate	GZ9708 - ID Letter R	GZ2016 - ID Letter B	1
20	Log Set	CE1559		11
21	Log Retainer	CA0807		

No.	Component	Part Code		
		Natural Gas	LPG	Quantity
22	Burner Assembly	GZ12756	GZ12757	1
23	RH Door Bracket	GZ12523		1
24	Lip Plate Casting	CA0803*		1
25	LH Door Bracket	GZ12522		1
26	Front Casting	CA0806*		1
27	Glass Frame Assembly	GZ12807		1
28	LH Reflector	GZ12828		1
29	Rear Lining Bracket	GZ13014		1
30	Rear Lining	CE1560		1
31	Top Lining	CE1561		1
32	LH Engine Mount	GZ12524		1
33	Embaglow	GZ8471		1
34	LH Side Casting	CA0801*		1
35	Interrupter Block	GC0026		1
36	Flue Sensor Leads	EL0064		1
37	Flue Sensor	EL0001		1
38	Blanking Plate	ME0608		

\*Use the additional suffix to assist in any correspondence. Black - No Suffix, Laurel Green - G, Midnight Blue - B, Ivory - V, Ivory Paint - MIV

Due to continual technical improvements please check online at [www.gazcospare.com](http://www.gazcospare.com) or with your Gazco retailer for the most up to date parts lists.

# Servicing Instructions - Replacing Parts

## 16. Spare Parts List - Huntingdon 30

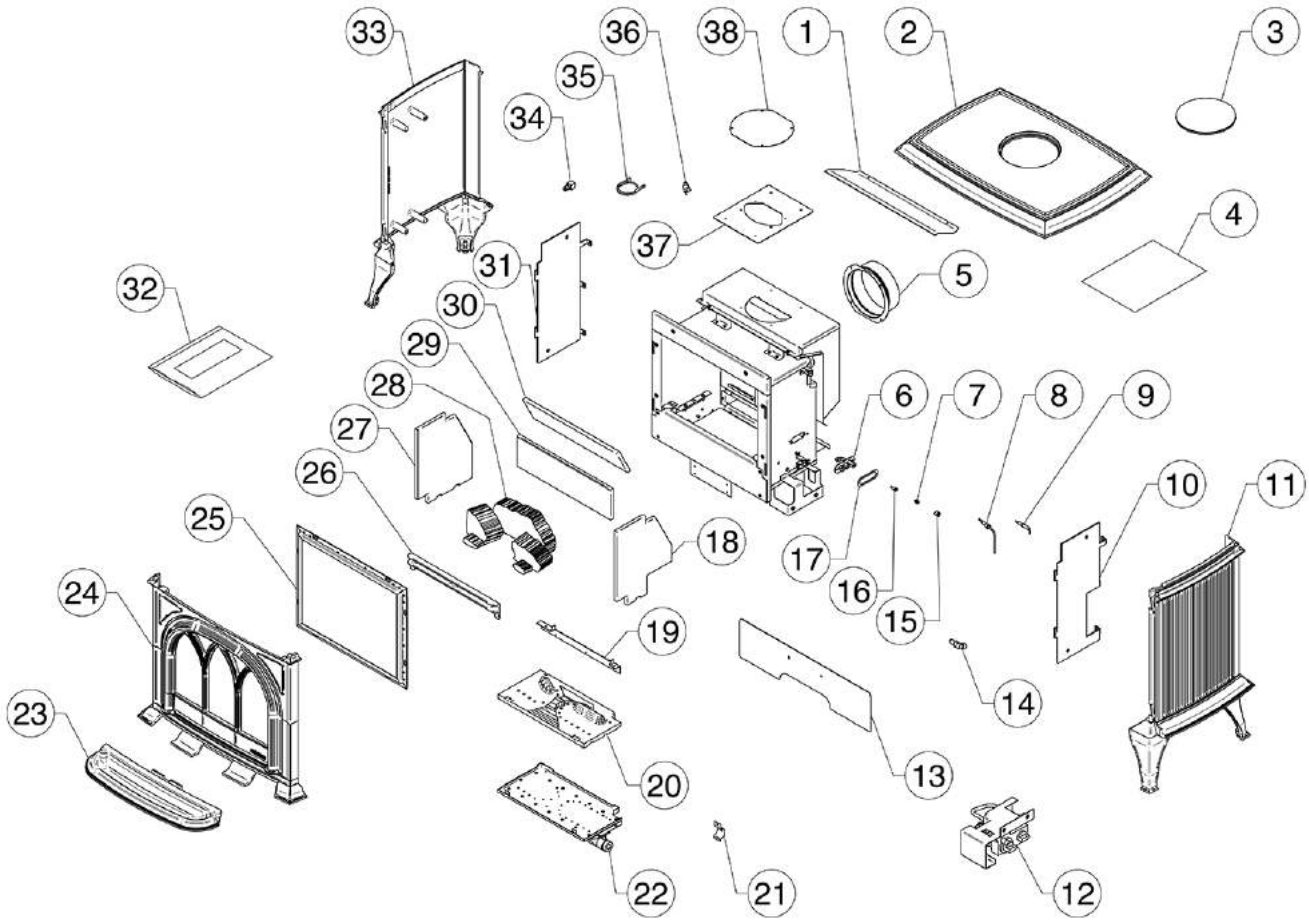

No.	Component	Part Code		
		Natural Gas	LPG	Quantity
1	Top Heat Shield	GZ10622		1
2	Top Casting	CA0645*		1
3	Blanking Plate	CA0720*		1
4	Instruction Manual	PR1811		1
5	Spigot	MEC0033		1
6	Pilot Burner Bracket	PI0051		1
7	Hook Olive	PI0013		1
8	Thermocouple	PI0011		1
9	Electrode	PI0053		1
10	RH Firebox Location Plate	GZ6222		1
11	RH Side casting	CA0641*		1
12	Control Assembly	B0216		1
13	Skirt	GZ6669		1
14	Elbow Injector	IN0001 - Size 260	IN0065 - Size 102	1
15	Hook Nut	PI0014		1
16	Pilot Burner Injector	PI0026	PI0015	1
17	Pilot Burner Gasket	PI0052		1
18	RH Ceramic Panel	CE0997		1
19	Rear log Retainer	GZ9553	GZ9758	1

No.	Component	Part Code		
		Natural Gas	LPG	Quantity
20	Ceramic Base Panel	CE0997	CE1024	1
21	Aeration Plate	GZ3270 - ID Letter D	GZ2025 - ID Letter E	1
22	Burner Assembly	GZ9712	GZ9713	1
23	Lip Plate Casting	CA0643*		1
24	Front casting	CA0642*		1
25	Glass Frame Assembly	GZ6025		1
26	Log Retainer	CA0744		1
27	LH Ceramic Panel	CE1013		1
28	Log Set	CE0960		1
29	Back Ceramic Panel	CE1015		1
30	Top Ceramic Panel	CE1016		1
31	LH Firebox Location Plate	GZ6221		1
32	Embaglow	GZ8471		1
33	LH Side Casting	CA0640		1
34	Interruptor Block	GC0026		1
35	Flue Sensor Leads	EL0064		2
36	Flue Sensor	EL0001		1
37	Offset Plate	ME10601		1
38	Blanking Plate	ME0608		1

\*Use the additional suffix to assist in any correspondence. Black - No Suffix, Laurel Green - G, Midnight Blue - B, Ivory - V, Ivory Paint - MIV

Due to continual technical improvements please check online at [www.gazcospare.com](http://www.gazcospare.com) or with your Gazco retailer for the most up to date parts lists.



# Servicing Instructions - Replacing Parts

## 16. Spare Parts List - Huntingdon 40

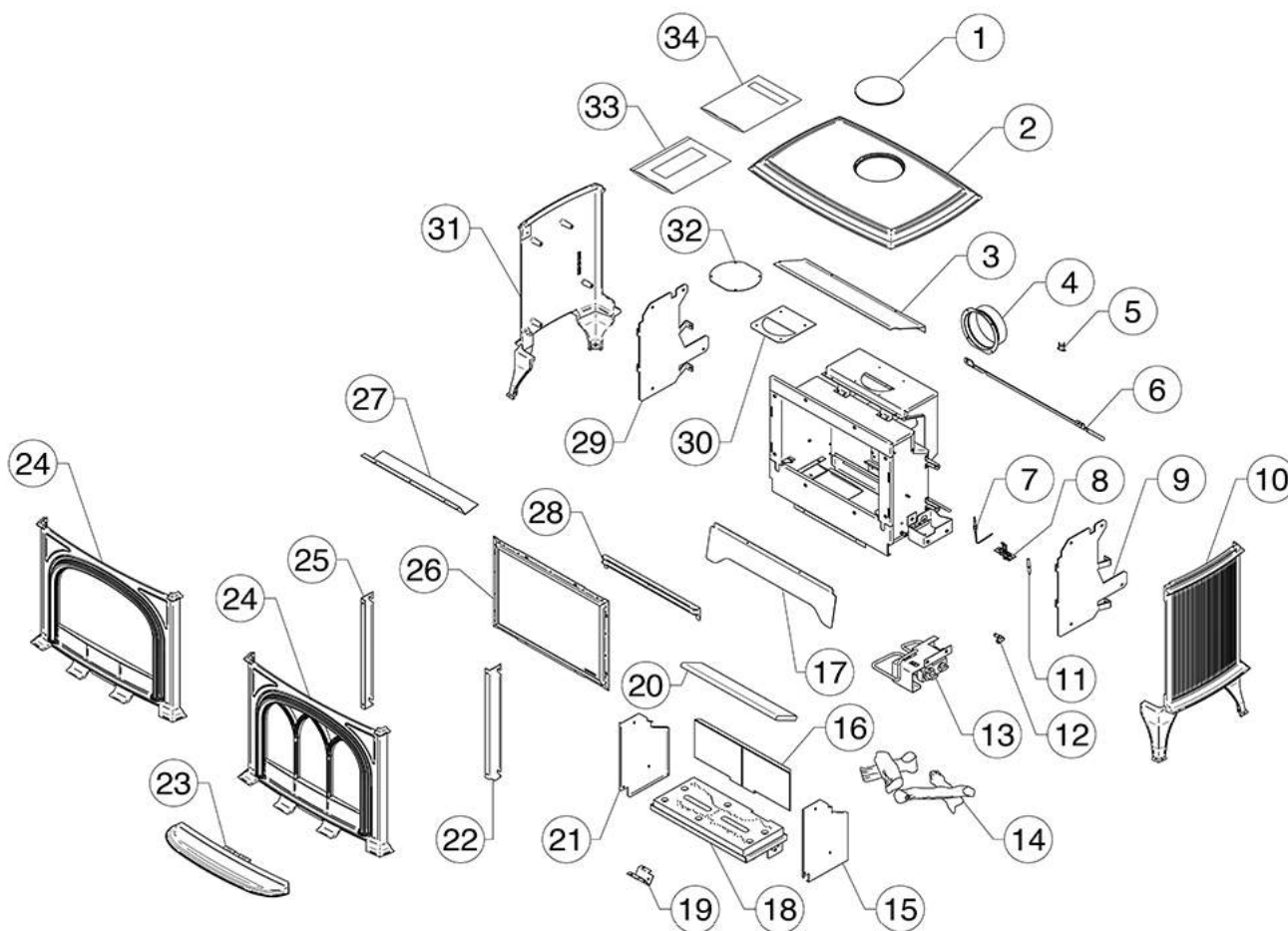

No.	Component	Part Code		
		Natural Gas	LPG	Quantity
1	Blanking Plate	CA0720*		1
2	Top Casting	CA0819*		1
3	Heat Shield	GZ1076		1
4	Spigot	MEC0033		1
5	Flue Sensor	EL0001		1
6	Rear Strap Support	GZ12582		1
7	Thermocouple	PI0074		1
8	Pilot	PI0069	PI0070	1
9	RH Firebox Location Plate	GZ12582		1
10	RH Side Casting	CA0816*		1
11	Electrode	PI0075		1
12	Injector	IN0076 - Size 67	IN0068 - Size 128	1
13	Engine Control Assembly	GZ12893		1
14	Log Set	CE1304		1
15	RH Relective Panel	GZ11015		1
16	Rear Liner Panel	CE1311		1
17	Vanity Cover	GZ12584		1

No.	Component	Part Code		
		Natural Gas	LPG	Quantity
18	Burner Assembly	GZ11001		1
19	Aeration Cover	GZ10406 - 6mmØ	GZ11214 - 13mmØ	1   2
20	Top Liner Panel	CE1312		1
21	LH Reflective Panel	GZ11014		1
22	RH Door Bracket	GZ12580		1
23	Lip Plate Casting	CA0818*		1
24	Clear Door - Matt Black	CA0814		1
	Tracery Door - Matt Black	CA0815*		1
25	LH Door Bracket	GZ12581*		1
26	Glass and Frame Assembly	GZ12805		1
27	Top Baffle	GZ11019		1
28	Log Retainer	CA0765		1
29	LH Firebox Location Plate	GZ12583		1
30	Offset Plate	ME11021		1
31	LH Side Casting	CA0817*		1
32	Blanking Plate	ME0608		1
33	Embaglow	GZ8471		1
34	Instruction Manual	PR1811		1

\*Use the additional suffix to assist in any correspondence. Black - No Suffix, Laurel Green - G, Midnight Blue - B, Ivory - V, Ivory Paint - MIV

Due to continual technical improvements please check online at [www.gazcospares.com](http://www.gazcospares.com) or with your Gazco retailer for the most up to date parts lists.

# Servicing Instructions - Replacing Parts

## 15. Short Spares List - Control Assembly

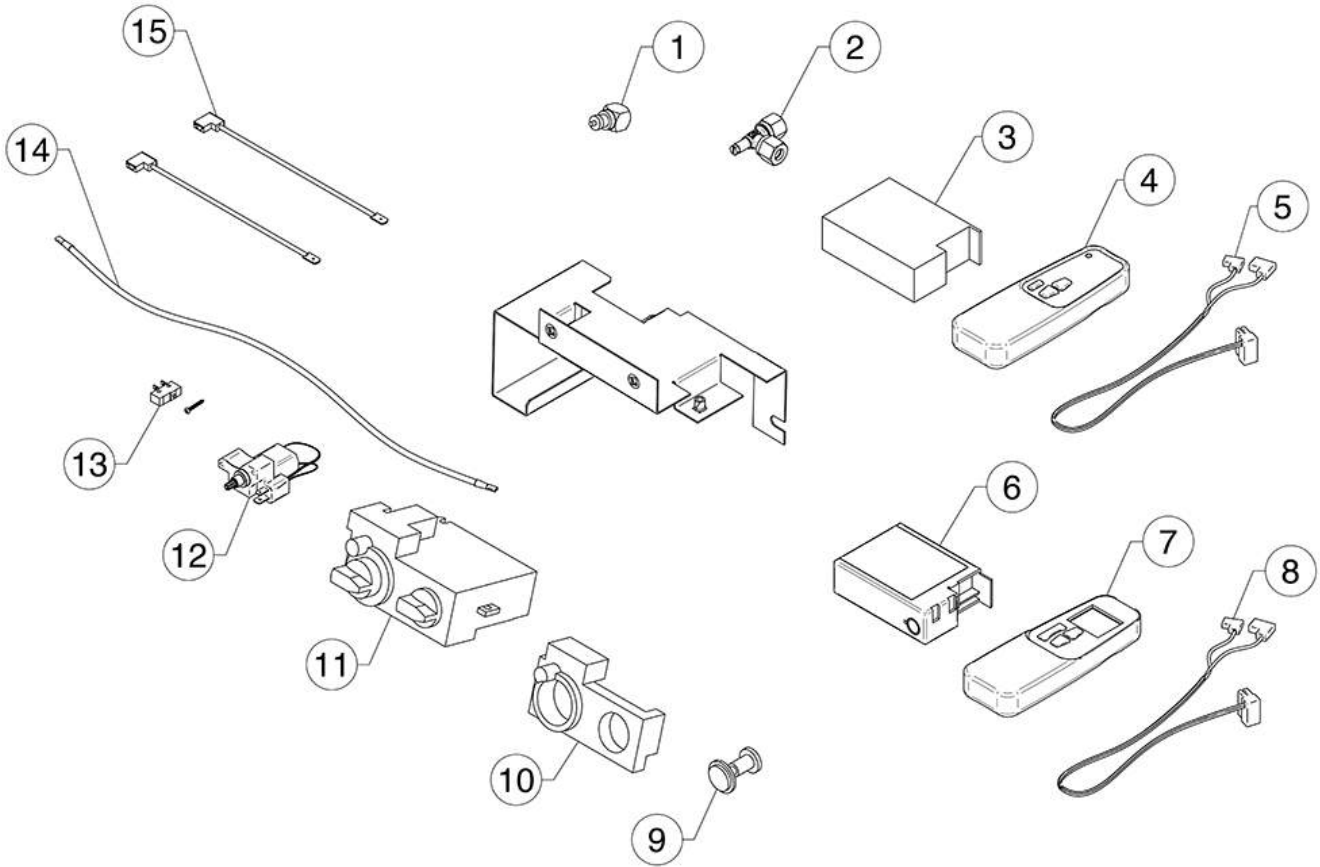

No.	Component	Part Code		
		Natural Gas	LPG	Quantity
1	Interrupter Block	GC0026		1
2	Pressure Test Elbow	IN0009		1
3	Standard Receiver	EL0235		1
4	Standard Handset	EL0239		1
5	Standard Receiver Cable	EL0237		1
6	Thermostatic Receiver	EL0236		1
7	Thermostatic Handset	EL0240		1
8	Thermostatic Receiver Cable	EL0238		1
9	Mag Unit	GC0166		1
10	Control Valve Cover	GC0087		1
11	Control Valve	GC0088K		1
12	Ignition Lead	GC0090		1
13	Micro Switch and Screw	EL0241		1
14	Ignition Lead	GC0090		1
15	Flue Sensor Lead	EL0064		2

Due to continual technical improvements please check online at [www.gazcospares.com](http://www.gazcospares.com) or with your Gazco retailer for the most up to date parts lists.

# Service Records

## 1ST SERVICE

Date of Service .....  
Next Service Due .....  
Signed .....  
Retailer's Stamp/GasSafe Registration Number

## 3RD SERVICE

Date of Service .....  
Next Service Due .....  
Signed .....  
Retailer's Stamp/GasSafe Registration Number

## 5TH SERVICE

Date of Service .....  
Next Service Due .....  
Signed .....  
Retailer's Stamp/GasSafe Registration Number

## 7TH SERVICE

Date of Service .....  
Next Service Due .....  
Signed .....  
Retailer's Stamp/GasSafe Registration Number

## 9TH SERVICE

Date of Service .....  
Next Service Due .....  
Signed .....  
Retailer's Stamp/GasSafe Registration Number

## 2ND SERVICE

Date of Service .....  
Next Service Due .....  
Signed .....  
Retailer's Stamp/GasSafe Registration Number

## 4TH SERVICE

Date of Service .....  
Next Service Due .....  
Signed .....  
Retailer's Stamp/GasSafe Registration Number

## 6TH SERVICE

Date of Service .....  
Next Service Due .....  
Signed .....  
Retailer's Stamp/GasSafe Registration Number

## 8TH SERVICE

Date of Service .....  
Next Due .....  
Signed .....  
Retailer's Stamp/GasSafe Registration Number

## 10TH SERVICE

Date of Service .....  
Next Service Due .....  
Signed .....  
Retailer's Stamp/GasSafe Registration Number

**Gazco Limited, Osprey Road, Sowton Industrial Estate, Exeter, Devon, England EX2 7JG**  
**Technical Customer Services: (01392) 261950 Fax: (01392) 261951**  
**E-mail: [technicalservices@gazco.com](mailto:technicalservices@gazco.com)**

A member of the Stovax Group  
E & O E