



Fire Your Imagination

Logic HE™ Range

Balanced Flue



Instructions for Use, Installation & Servicing

For use in GB & IE (Great Britain & Republic of Ireland).

IMPORTANT

THE OUTER CASING, FRONT AND GLASS PANEL BECOME EXTREMELY HOT DURING OPERATION AND WILL RESULT IN SERIOUS INJURY AND BURNS IF TOUCHED. IT IS THEREFORE RECOMMENDED THAT A FIREGUARD COMPLYING WITH BS 8423 (LATEST EDITION) IS USED IN THE PRESENCE OF YOUNG CHILDREN, THE ELDERLY OR INFIRM.

This product contains a Heat resistant glass panel. This panel should be checked during Installation and at each servicing interval. If any damage is observed on the front face of the glass panel (scratches, scores, cracks or other surface defects), the glass panel must be replaced and the appliance must not be used until a replacement is installed. Under no circumstances should the appliance be used if any damage is observed, the glass panel is removed or broken.

It is essential that ALL of the screws that retain the glass frame are replaced and tightened correctly. Under no circumstances should the appliance be operated if any of these screws are loose or missing.

These Instructions must be left with the appliance for future reference and for consultation when servicing the appliance. Please make the customer aware of the correct operation of the appliance before leaving these instructions with them.

The commissioning sheet found on Page 3 of this Instruction manual must be completed by the Installer prior to leaving the premises.

Contents

Logic HE Balanced Flue

Covering the following models:

GAS TYPE	LOGIC HE BF					
	Manual Control		Remote Control		Slide Control	
	Coal	White Stones	Coal	White Stones	Coal	White Stones
Nat Gas	101-135	101-208	101-174	101-182	101-237	101-386
LPG	101-458	101-687	101-738	101-777	101-639	101-753

Appliance Commissioning Checklist3

User Instructions.....4

Installation Instructions12

Technical Specification for White Stone Effect 12

Technical Specification for Coal Effect 13

Site Requirements..... 16

Installation 19

Commissioning.....29

Servicing Instructions.....30

Fault Finding..... 30

How to replace parts 33

Basic spare parts list 41

Service Records 52

Information Requirements.....53



To receive your Extended Warranty your Gazco appliance must have been purchased from our Expert Retailer Network and registered within one month of purchase or installation. Please note that all warranties are effective from the date of purchase. Any Gazco product purchased outside of our Extended Retailer Network, or not registered within the stated time will carry a standard 12 month warranty.

It is a condition of the Extended Warranty that the installation complies with the relevant Building Regulations and is carried out by a suitably trained and qualified individual (GasSafe in the UK or equivalent in other countries) with the certificate of installation and the Commissioning Report on Page 3 completed and retained by the end user.

Full terms and conditions are detailed in the Warranty Statement on the Gazco website www.gazco.com. In the event of any conflict of information the wording on the website shall prevail.

Important Note: Should any problems be experienced with your product, claims must first be submitted to the Expert Retailer where the appliance was purchased from who will offer immediate assistance or contact Gazco on your behalf.



It is a requirement of the Building Regulations 2010 that the installation of this appliance is notified to the Local Authority. It is the responsibility of the GasSafe registered installer to carry out this notification to the Local Authority via the GasSafe register Competent Persons Scheme in England and Wales (different rules apply in Scotland and Northern Ireland).

When the installation has been notified, GasSafe will send a Building Regulations Compliance Certificate to you containing details of the work completed. Please ensure that the person responsible for the installation of this appliance completes this notification and records it in the Appliance Commissioning Checklist on page 3.

IT IS YOUR RESPONSIBILITY TO COMPLY WITH THE BUILDING REGULATIONS AND BE ABLE TO PRODUCE THIS CERTIFICATE SHOULD IT BE REQUIRED IN THE FUTURE.

Appliance Commissioning Checklist

To assist us in any guarantee claim please complete the following information:-

IMPORTANT NOTICE

Explain the operation of the appliance to the end user, hand the completed instructions to them for safe keeping, as the information will be required when making any guaranteed claims.

FLUE CHECK	PASS	FAIL
1. Flue Is correct for appliance		
2. Flue flow Test N/A		
3. Spillage Test N/A		
GAS CHECK		
1. Gas soundness & let by test		
2. Standing gas pressure	mb	
3. Appliance working pressure (on High Setting) Minimum Pressure Requirement: NG - 17.5mbar LPG - 34.5mbar NB All other gas appliances must be operating on full	mb	
4. Gas rate	m ³ /h	
5. Does Ventilation meet appliance requirements N/A		
SAFETY CHECK		
1. Check soundness of the Thermocouple connections - including tightness and lead integrity		
2. Glass checked to ensure no damage, scratches, scores or cracks		
3. Glass frame secured correctly and all screws replaced		
BUILDING CONTROL NOTIFICATION	YES	NO
1. Installer notified GasSafe/Local Authority of installation via Competent Persons Scheme?		

RETAILER AND INSTALLER INFORMATION

Retailer	Installation Company
Contact No.	Engineer
Date of Purchase	Contact No.
Model No.	GasSafe Reg No.
Serial No.	Date of Installation
Gas Type	

User Instructions

Welcome

Congratulations on purchasing your Logic HE fire, if installed correctly Gazco hope it will give you many years of warmth and pleasure for which it was designed.

The purpose of this manual is to familiarise you with your appliance, and give guidelines for its installation, operation and maintenance. If, after reading, you need further information, please do not hesitate to contact your Gazco retailer.

WARNING



In the event of a gas escape or if you can smell gas, please take the following steps:

- **Immediately turn off the gas supply at the meter/emergency control valve**
- **Extinguish all sources of ignition**
- **Do not smoke**
- **Do not operate any electrical light or power switches (On or Off)**
- **Ventilate the building(s) by opening doors and windows**
- **Ensure access to the premises can be made**

Please report the incident immediately to the National Gas Emergency Service Call Centre on 0800 111 999 (England, Scotland and Wales), 0800 002 001 (N. Ireland) or in the case of LPG, the gas supplier whose details can be found on the bulk storage vessel or cylinder.

The gas supply must not be used until remedial action has been taken to correct the defect and the installation has been recommissioned by a competent person.

1. General

- 1.1 Installation and servicing must only be carried out by a competent person whose name appears on the GasSafe register. To ensure the engineer is registered with GasSafe they should possess an ID Card carrying the following logo:



- 1.2 In all correspondence, please quote the appliance type and serial number, which can be found on the data badge adjacent to the control knob.
- 1.3 **Do not** place curtains above the appliance: You must have 300mm clearance between the appliance and any curtains at either side.

- 1.4 No furnishings or other objects should be placed within 1 metre of the front of the appliance.
- 1.5 If a shelf is fitted, a distance of 300mm above the appliance opening is required.
- 1.6 If any cracks appear in the glass panel do not use the appliance until the panel has been replaced.
- 1.7 Do not obstruct the flue terminal in any way, i.e. by planting flowers, trees, shrubs etc. in the near vicinity, or by leaning objects against the terminal guard.
- 1.8 Do not put any objects on the terminal guard; it will lose its shape.
- 1.9 If you use a garden sprinkler, do not let quantities of water into the flue terminal.
- 1.10 This product is guaranteed for 5 years from the date of installation, as set out in the terms and conditions of sale between Gazco and your local Gazco retailer. Please consult with your local Gazco retailer if you have any questions. In all correspondence always quote the Model Number and Serial Number.



IMPORTANT: NEVER position a television or screen above this appliance.

2. Operating the Appliance

- 2.1 There are three types of control systems available for this appliance:
1. Manually Operated Control
 2. Remote Control
 3. Slide Control
- Follow the relevant section for specific operation.

Manual Control

- 2.2 Locate the control valve on the appliance. It has a single manual control, see Diagram 1:

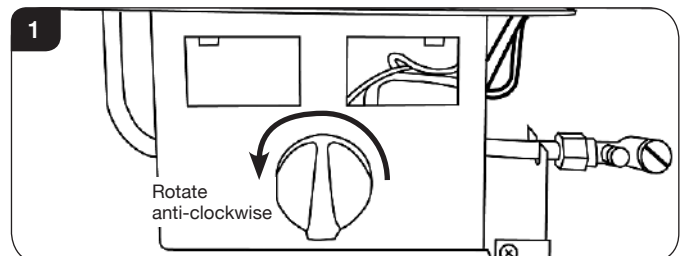

Lighting the Pilot

- 2.3 Push the valve knob in and rotate anti-clockwise slowly until a click is heard. The pilot should now be lit.

User Instructions

- 2.4 Hold in for a further 10 seconds.
When released the pilot should remain lit.

If the pilot does not remain lit, repeat until the operation is successful.

Locating the Pilot

Coal Effect

The pilot is located on the front right hand side of the appliance. To view the pilot look down through the GAZCO logo between the glass and the front coal, see Diagram 2.

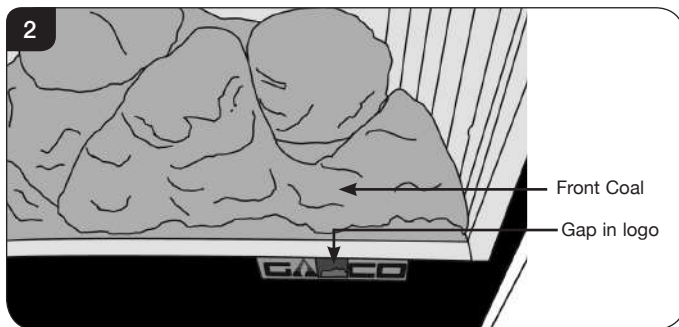

White Stone Effect

The pilot is located on the rear right hand side of the appliance and is clearly visible when lit, see Diagram 3.

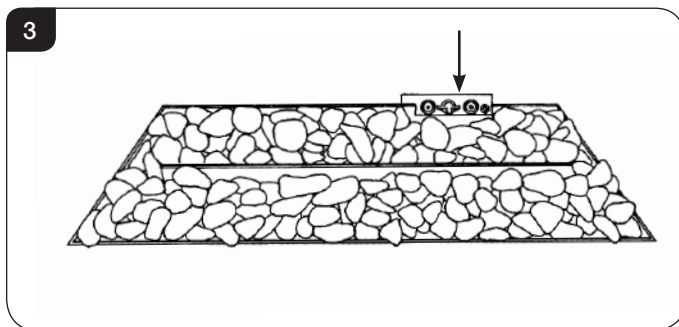

Adjusting the Flame height

- 2.5 From the pilot position push the valve knob in slightly and rotate anti-clockwise until the first stop point is felt. This denotes the lowest setting.
- 2.6 Push the valve knob in slightly and rotate further in an anti-clockwise direction. The final stop point is the highest setting.

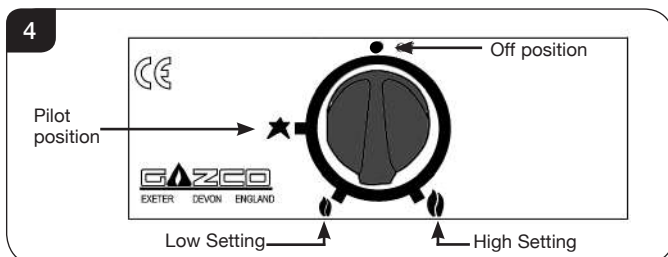

i **IMPORTANT: YELLOW FLAMES TYPICALLY APPEAR WHEN THE APPLIANCE HAS REACHED NORMAL OPERATING TEMPERATURE. THIS CAN TAKE UP TO 30 MINUTES.**

! **WARNING: IF THE APPLIANCE FAILS TO LIGHT OR BECOMES EXTINGUISHED IN USE, WAIT 3 MINUTES BEFORE ATTEMPTING TO RELIGHT.**

Switching OFF the Appliance

- 2.7 To switch the appliance off turn the control knob clockwise until it is returned to the off position, see Diagram 5.

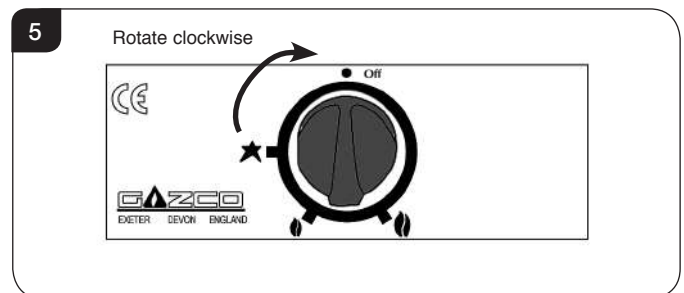

The knob should be upright.

Remote Control

The pilot on Remote Control appliances must be lit manually from the valve unit before operation.

The control valve is at the foot on the right-hand side of the appliance. It has two controls, see Diagram 6:

1. The right-hand knob controls the pilot ignition.
2. The left-hand knob controls the main burner.

Lighting the Pilot

- 2.8 To start the left-hand and right-hand control knobs must both point to off (●):

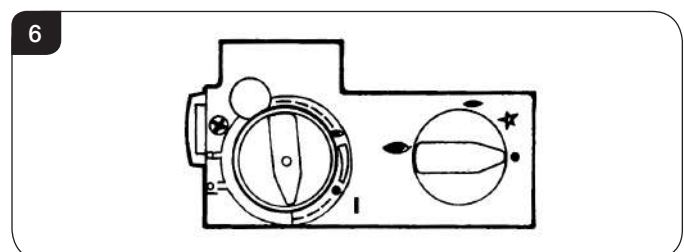

- 2.9 Press in the right-hand control knob and rotate anti-clockwise until a click is heard. Continue to press in. The knob points to the pilot (★).

The pilot is lit.

- 2.10 Keep the knob depressed for 10 seconds before releasing. The pilot remains lit.

Repeat the above steps if the pilot does not stay lit.

User Instructions

NOTE: If the pilot goes out, the Interlock system prevents you lighting again for a short period.

- 2.11 If, after repeating the above steps the pilot does not light, contact your Retailer or Installer.
- 2.12 Turn the right-hand control to point to main burner (👁️). The appliance can now be controlled by the remote handset.
- 2.13 The Standard remote controls the appliance when:
 - the pilot is lit.
 - the right-hand control points to main burner 👁️ ready to operate position.

It regulates the temperature from low to high and back. It can also turn the main burner off leaving just the pilot burning and ready to operate.

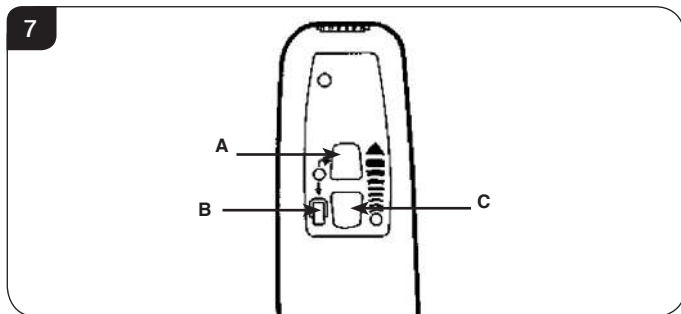

To light the main burner:

- 2.14 Press buttons A & B simultaneously. The remote's LED light flashes to show communication between the appliance's controls and the remote.

Adjusting the Flame height:

- 2.15 Press and hold buttons A & B simultaneously to increase the flame height. A clicking sound indicates that the appliance is at maximum.
- 2.16 Press and hold button C to decrease the flame height. Continue to press C to turn off the main burner.

To make small adjustments to flame height:

- 2.17 Press and hold down button B and press button A once to make a slight increase. This increases the temperature by stages.

Repeat to further adjust.

- 2.18 Press button C once to slightly reduce the flame height.

i IMPORTANT: YELLOW FLAMES TYPICALLY APPEAR WHEN THE APPLIANCE HAS REACHED NORMAL OPERATING TEMPERATURE. THIS CAN TAKE UP TO 30 MINUTES.

! WARNING: IF THE APPLIANCE FAILS TO LIGHT OR BECOMES EXTINGUISHED IN USE, WAIT 3 MINUTES BEFORE ATTEMPTING TO RELIGHT.

Switching OFF the Appliance

THE REMOTE CONTROL CAN TURN THE MAIN BURNER OFF AND LEAVE THE PILOT BURNING AND READY TO OPERATE 👁️.

- 2.19 To switch off the appliance completely (no pilot burning) return both control knobs to the off position (●).

Remote Control

- 2.20 To turn the main burner of the appliance off using the handset press and keep pressing the Off button (●).

The main burner goes out leaving the pilot burning and ready to operate 👁️.

Controls on Appliance

- 2.21 Use the controls on the appliance to turn the appliance off by turning the left-hand control knob until it points to Off (●). A click is heard and the main burner goes out leaving the pilot burning and ready to operate 👁️.

CAUTION: IN RARE INSTANCES, NOISES FROM SOURCES OUTSIDE THE REMOTE CAN OPERATE THE MAIN BURNER. IF THIS OCCURS, ALWAYS TURN THE CONTROL TO PILOT (👁️) OR OFF.

Slide Control

This appliance is operated using the slide control on the top right hand side of the decorative front.

When the appliance is OFF the slide control will be at the highest point, see Diagram 8.

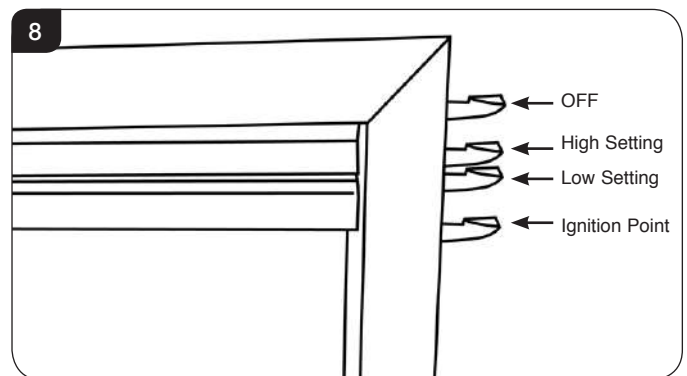

Lighting the Pilot

- 2.22 Push the slide control down as far as possible to its lowest point, see Diagram 8, this is the ignition point.

Keep the slide control pressed down for 5 seconds to ensure the pilot is lit. Then release.

The appliance should light on its lowest setting.

- 2.23 When released the slide control automatically raises to a natural stop point, see Diagram 8.

Repeat the above steps if the appliance does not light.

- 2.24 If, after repeating the above steps the pilot does not light, contact your Retailer or Installer.

User Instructions

Adjusting the Flame height

- 2.25 Increase the flame height and temperature by carefully moving the slide control up until the next stop point is felt, see Diagram 8. This denotes the highest setting.
- 2.26 Carefully move the slide control down to the lower stop point to return to the lowest setting.

i **IMPORTANT: YELLOW FLAMES TYPICALLY APPEAR WHEN THE APPLIANCE HAS REACHED NORMAL OPERATING TEMPERATURE. THIS CAN TAKE UP TO 30 MINUTES.**

! **WARNING: IF THE APPLIANCE FAILS TO LIGHT OR BECOMES EXTINGUISHED IN USE, WAIT 3 MINUTES BEFORE ATTEMPTING TO RELIGHT.**

Switching OFF the Appliance

- 2.27 To turn the appliance off lift the slide control to its highest stop point, see Diagram 8. The pilot goes out.

3. Changing the Battery

Remote Control

- 3.1 The battery box is located at the bottom left of the appliance behind the ash cover.
- 3.2 Remove the old batteries and replace with a new high quality (Duracell or similar) 4 AA batteries.

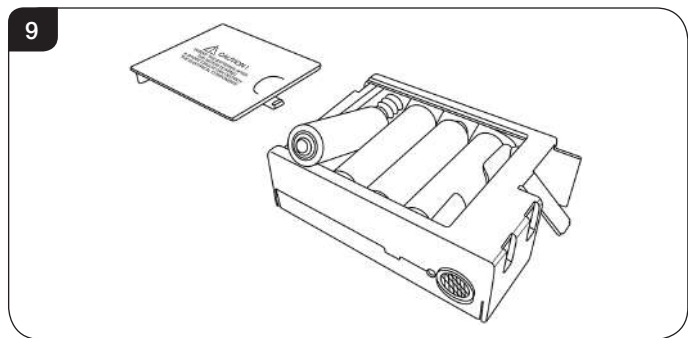

i **It is essential to use high quality batteries (Duracell or equivalent) when replacing batteries.**

Slide Control

- 3.3 The battery box is located at the bottom left of the appliance behind the ash cover, see Diagram 10.

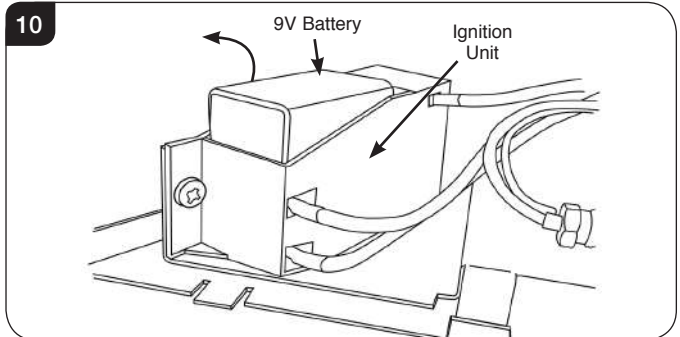

- 3.4 Remove the old battery and replace with a new high quality (Duracell or similar) 9V battery.

i **It is essential to use high quality batteries (Duracell or equivalent) when replacing batteries.**

4. Cleaning the Appliance

- 4.1 Make sure the appliance and surrounds are cool before trying to clean.
- 4.2 Refer to the separate decorative front instructions to remove the front from the appliance.
- 4.3 Remove the glass frame by unscrewing the 2 lower outer pozi head screws, see Diagram 11, Arrow A, by several turns, there is no need to fully remove these 2 screws.
- 4.4 Remove the remaining 6 screws, see Diagram 11, Arrow B.

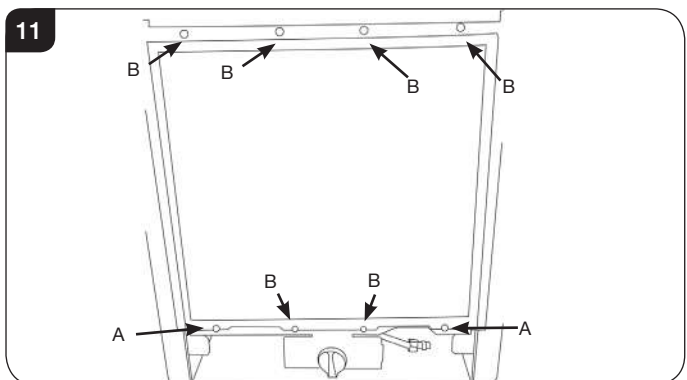

- 4.5 Lift the glass frame clear of the appliance and carefully place to one side.
- 4.6 To clean the glass surface, Gazco recommends you use hot soapy water.
- 4.7 The glass frame must be refitted to the appliance following cleaning or servicing. Ensure that the fibre glass seal on the box is intact, then lower the glass frame onto the 2 lower fixing screws, see Diagram 11, Arrow A.

User Instructions

- 4.8 Fit the other 6 fixing screws, see Diagram 11, Arrow B.
- 4.9 Tighten all 8 screws to secure the frame, see Diagram 11. Replace ALL of the securing screws ensuring that a screw is present in all fixing slots.

NEVER OPERATE THE APPLIANCE WHEN THE GLASS FRAME IS REMOVED OR BROKEN.

Refer to the separate decorative front instructions to replace the front on the appliance.



UNDER NO CIRCUMSTANCES SHOULD THE APPLIANCE BE USED IF ANY OF THE GLASS FRAME RETAINING SCREWS ARE LOOSE OR MISSING.

White Stone Effect

- 4.10 Remove the white stones and place on a dry clean surface. Do not remove the enamel back panel.
- 4.11 Use a damp cloth and mild non-abrasive cleaner on the enamel back panel.
- 4.12 Carefully clean the burner and tray assembly using a vacuum cleaner with soft brush attachment, ensure all debris is removed from the burner ports.
- 4.13 Replace the white stones by referring to Section 5A.

Coal Effect

- 4.14 Remove the ceramic coals and fuel bed and place on a dry clean surface.
- 4.15 Check the burner cover gasket for damage. Replace any damaged parts with genuine Gazco replacement parts, contact your Gazco retailer.
- 4.16 Carefully clean the burner and tray assembly using a vacuum cleaner with soft brush attachment, ensure all debris is removed from the burner ports.

WARNING: Take care when using a vacuum cleaner on the burner gasket as this is extremely delicate and may deteriorate after use.

- 4.17 Replace the ceramics by referring to section 5B.

5. Arrangement of the Fuel Bed

Advice on handling and disposal of fire ceramics



The fuel effect and side panels of this appliance are made from Refractory Ceramic Fibre (RCF), a material which is commonly used for this application.

Protective clothing is not required when handling these articles, but we recommend you follow normal hygiene rules of not smoking, eating or drinking in the work area and always wash your hands before eating or drinking.

To ensure that the release of RCF fibres are kept to a minimum, during installation and servicing a HEPA filtered vacuum is recommended to remove any dust accumulated in and around the appliance before and after working on it. When servicing the appliance it is recommended that the replaced items are not broken up, but are sealed within heavy duty polythene bags and labelled as RCF waste.

RCF waste is classed as stable, non-reactive hazardous waste and may be disposed of at a licensed landfill site.

Excessive exposure to these materials may cause temporary irritation to eyes, skin and respiratory tract; wash hands thoroughly after handling the material.

5A. White Stone Layout

ONLY USE THE CORRECT TYPE AND QUANTITY OF WHITE STONES. ALWAYS FOLLOW THE FUEL BED LAYOUT AS STATED IN THESE INSTRUCTIONS. NEVER CHANGE THE LAYOUT FROM THAT SHOWN HERE.

- 5.1 Arrange the white stones in the areas highlighted in Diagram 12. They should be evenly distributed.

12



User Instructions

- 5.2 Lean the white stones against the burner ledges to disguise the ledges, see Diagram 13.

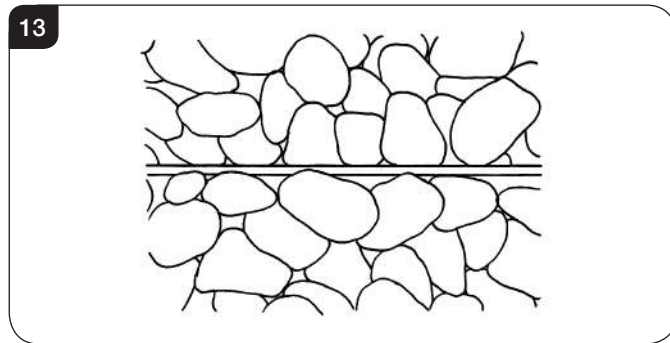

- 5.3 Check that the port area, see Diagram 14, Arrow A is clear of white stones. This can be easily done by gently running a screwdriver or similar object along this area.

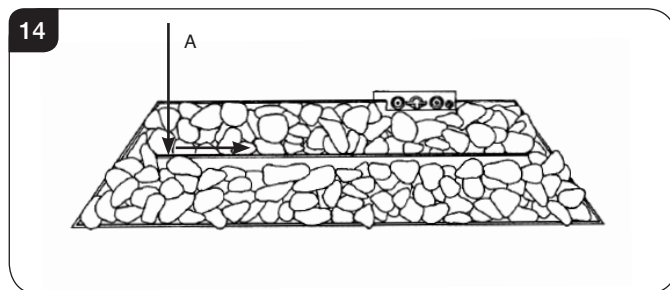

NOTE: IT IS IMPORTANT THE WHITE STONES DO NOT COVER THE PORT AREA IN BETWEEN THE BURNER LEDGES.

- 5.4 Ensure that no stones overhang or fill the pilot area, see Diagram 15, Arrow B.

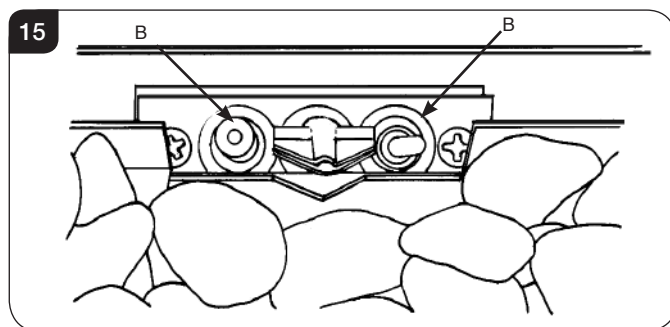

NOTE: STONES SHOULD NOT BE PLACED DIRECTLY IN FRONT OF THE PILOT CROSS LIGHTING FLAME.

5B. Coal Effect Layout

**NOTE: CERAMIC PARTS ARE FRAGILE. HANDLE WITH CARE.
ONLY USE THE CORRECT TYPE AND QUANTITY OF CERAMIC COMPONENTS.**

- 5.5 Place the rear panel against the rear of the box resting on the shelf.
- 5.6 Slide one of the side panels into the box ensuring it touches the rear panel.
- 5.7 Gently ease the front edge of the side panel behind the flange so it lies flat against the wall of the box.
- 5.8 Repeat with the second side panel, see Diagram 16.

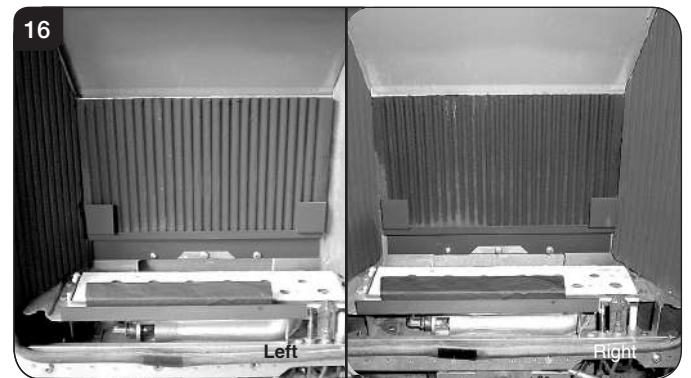

- 5.9 Locate the top panel on top of the sides and rear by lifting it up and forward inside the box.
- 5.10 Slide it backwards and down behind the side panels to rest on the rear panel, see Diagram 17.

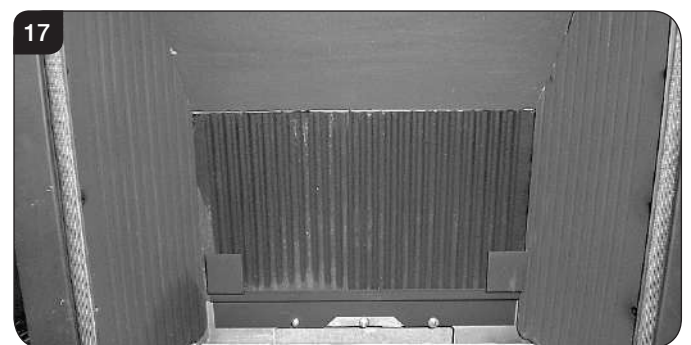

- 5.11 Position the flame baffle centrally on the tray and ensure the stepped lower edge engages against the rear edge of the burner skin, see Diagram 18.

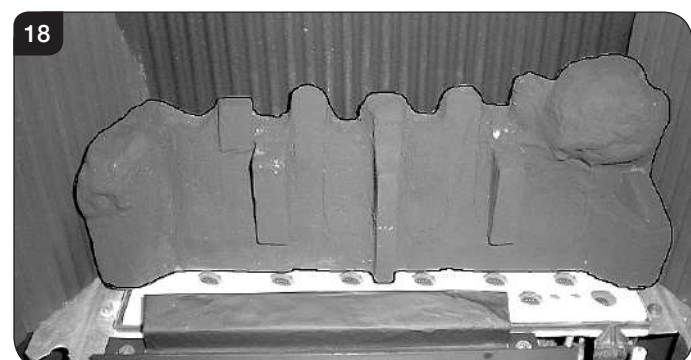

User Instructions

- 5.12 Place the front coal centrally in the channel at the front of the tray. The relationship between the front coal and the flame baffle is shown, see Diagram 19.

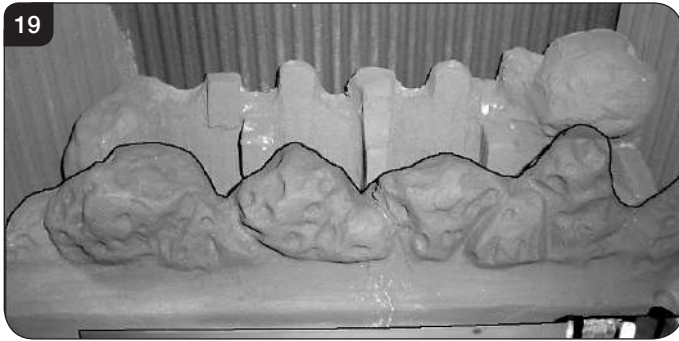

- 5.13 There are three sizes of coal used. Small x3, medium x4 and large x1. For identification, see Diagram 20.

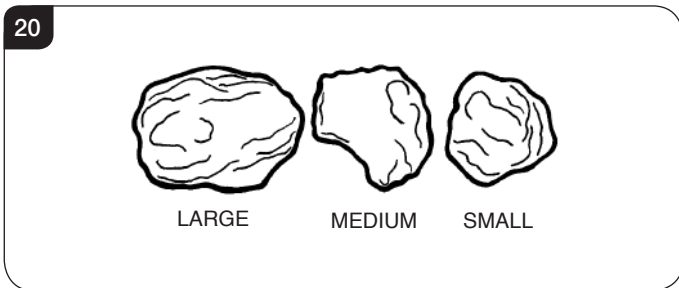

- 5.14 Place the single large coal in the central dent of the front coal resting against the flame baffle, see Diagram 21.

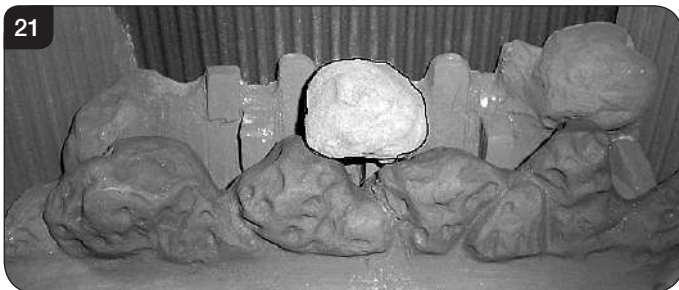

- 5.15 Place the left front medium coal in the recess between the flame baffle and the front coal, see Diagram 22.



- 5.16 Place the front right medium coal on the front coals and against the flame baffle, see Diagram 23.



- 5.17 Place the rear left medium coal on the recess behind the front row of coals resting on the rear panel, see Diagram 24.



- 5.18 Place the rear right medium coal in the recess behind the front row of coals resting on the rear pane, see Diagram 25.



- 5.19 Place the right hand small coal in the recess between the flame baffle and the front coal, see Diagram 26.

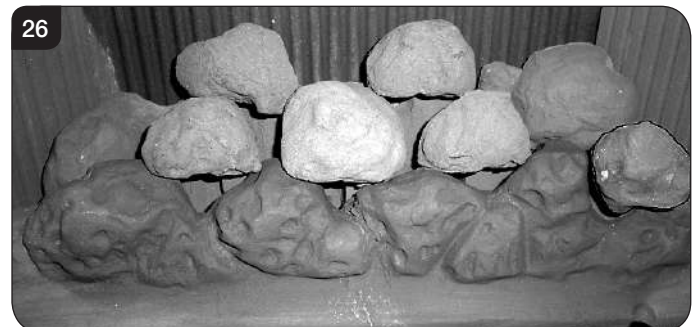

User Instructions

- 5.20 Place the left hand small coal in the recess between the flame baffle and the front coal, see Diagram 27.



- 5.21 Place the centre rear small coal in the recess behind the large centre coal, see Diagram 28.



- 5.22 It is essential that gaps are left between the coals to maximise the performance of the appliance.

6. Flame Failure Device

- 6.1 This is a safety feature incorporated on this appliance which automatically switches off the gas supply if the pilot goes out and fails to heat the thermocouple.

IF THIS OCCURS DO NOT ATTEMPT TO RELIGHT THE APPLIANCE FOR 3 MINUTES.

7. Running In

- 7.1 During initial use of a new GAZCO appliance a strong odour will be encountered as various surface coatings become hot for the first time. Although these odours are harmless it is recommended that the appliance is operated on maximum for 4 to 8 hours in order to fully burn off these coatings. After this period the odours should then disappear.
- If the odours persists, please contact your installer for advice.
- 7.2 During the first few hours of burning there may be discolouration of the flames. This will also disappear after a short period of use.

8. Servicing

- 8.1 The appliance must be serviced every 12 months by a qualified GasSafe Engineer. In all correspondence always quote the Model number and the Serial number which may be found on the Commissioning Checklist (Page 3).

9. Ventilation

- 9.1 This appliance requires no additional ventilation.

10. Installation Details

- 10.1 Your installer should have completed the commissioning sheet at the front of this book. This records the essential installation details of the appliance. In all correspondence always quote the Model number and Serial number.

11. Hot Surfaces

- 11.1 Parts of this appliance become hot during normal use.
- 11.2 Regard all parts of the appliance as a working surface, except for the control access panel and the slider handle (slide control model only).
- 11.3 Provide a suitable fire guard to protect young children and the infirm.

Installation Instructions

Technical Specification - Stone Effect

Covering the following models:

Gas Type	Logic HE Stone Effect		
	Manual Control	Remote Control	Slide Control
Nat Gas	101-208	101-182	101-386
LPG	101-687	101-777	101-753

Model		Gas Cat.	Gas Type	Working Pressure	Aeration	Injector	Gas Rate m ³ /hr		Input kW (Gross)		Country
							High	Low	High	Low	
Logic HE	Manual	I ₂ H	Natural G20	20mb	6mm x 10mm	200	0.324	0.2	3.4	2.1	GB, IE
	Remote										
	Slide										
Logic HE	Manual	I ₃ P	Propane G31	37mb	12mm x 15mm	95	0.128	0.079	3.4	2.1	GB, IE
	Remote										
	Slide										
Efficiency 86% Net (Class 1)											
NOx Class 4											
Flue Outlet Size Ø 100mm											
Flue Inlet Size Ø 152mm											
Gas Inlet Connection Size Ø 8mm											

i The net efficiency of this appliance has been measured as specified in EN613:2001 and the result after conversion to gross using the appropriate factor from Table E4 of SAP 2012 is 77.5%. The test data has been certified by BSI Testing Services. The gross efficiency value may be used in the UK Government's Standard Assessment Procedure (SAP) for energy rating of dwellings.

Installation Instructions

Technical Specification - Coal Effect

Covering the following models:

Gas Type	Logic HE Coal Effect		
	Manual Control	Remote Control	Slide Control
Nat Gas	101-135	101-174	101-237
LPG	101-458	101-738	101-639

Model		Gas Cat.	Gas Type	Working Pressure	Aeration	Injector	Gas Rate m ³ /hr		Input kW (Gross)		Country
							High	Low	High	Low	
Logic HE	Manual	I ₂ H	Natural G20	20mb	8mm x 15mm	260	0.381	0.219	4.0	2.3	GB, IE
	Remote						0.400	0.219	4.2	2.3	
	Slide						0.39	0.219	4.1	2.3	
Logic HE	Manual	I ₃ P	Propane G31	37mb	23mm x 15mm (2)	104	0.150	0.083	4.0	2.2	GB, IE
	Remote						0.154	0.083	4.1	2.2	
	Slide						0.154	0.083	4.1	2.2	
Efficiency 86% Net (Class 1)											
NOx Class 3											
Flue Outlet Size Ø 100mm											
Flue Inlet Size Ø 152mm											
Gas Inlet Connection Size Ø 8mm											

i The net efficiency of this appliance has been measured as specified in EN613:2001 and the result after conversion to gross using the appropriate factor from Table E4 of SAP 2012 is 77.5%. The test data has been certified by BSI Testing Services. The gross efficiency value may be used in the UK Government's Standard Assessment Procedure (SAP) for energy rating of dwellings.

Installation Instructions

Technical Specification

Complete Front Options

FRONT	Manual & Remote	Slide Control
DESIGNIO	912-396, 912-018	-
DESIGNIO 2	901-493, 901-511, 901-526	901-539, 901-580, 901-643
EVOLUTION	912-601	-
FUTURA	8687BK	-
FUSION	8699GP + 8699IR	-
PROGRESS	912-239	-
TEMPO	912-197, 912-221, 912-316	901-385, 901-403, 901-414
WINCHESTER	8697MB + 8697P	901-369, 901-372
DIMENSION2	912-322	-
STEEL **	8695GP + 8695IR	-
RICHMOND *	8679	-
STOCKTON *	8696	-
YEOMAN *	YM98906	-

Frame & Front Combinations

FRAMES				
	Box Profil2 Frame ***		Arts2 Frame ***	
FINISH	Manual & Remote	Slide	Manual & Remote	Slide
Matt Black	912-232	901-272	912-862	901-167
Polished Brass Effect	912-140	901-286	-	-
Polished Steel Effect	912-027	901-299	-	-
Brushed Steel Effect	912-358	901-310	-	-
Polished Brass	-	-	912-508	901-194
Polished Stainless	-	-	912-914	901-206
Brushed Stainless	-	-	912-268	901-214

FRONTS					
	Arts Front	Wave Front	Chartwell Front	Holyrood Front *	Spanish Front *
FINISH	All Models	All Models	All Models	All Models	All Models
Matt Black	901-425	901-024	901-159	912-020	912-083
Polished Brass Effect	901-530	901-061	901-164	912-226	912-160
Highlight Polished	901-296	901-092	901-185	912-257	912-127
Polished Chrome	901-476	901-083	901-170	912-392	912-216

* Not available on the Stone Effect

** Not available on the Coal Effect

*** A Box Profil2 Frame or Arts2 Frame must be used in conjunction with an Arts, Wave, Chartwell, Holyrood or Spanish Front

Installation Instructions

Technical Specification

OVERALL EXTERNAL DIMENSIONS

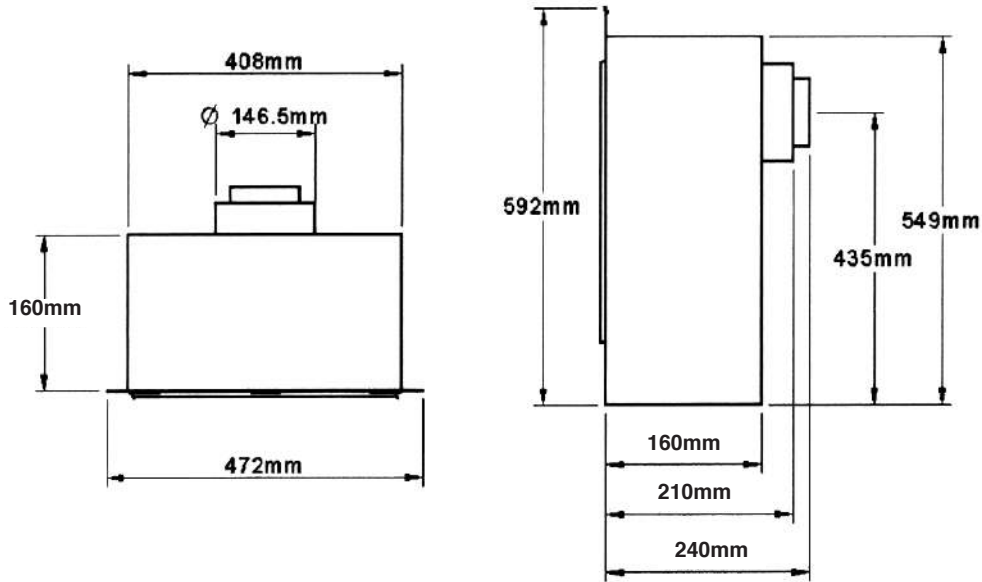

MINIMUM AND MAXIMUM FLUE SIZE

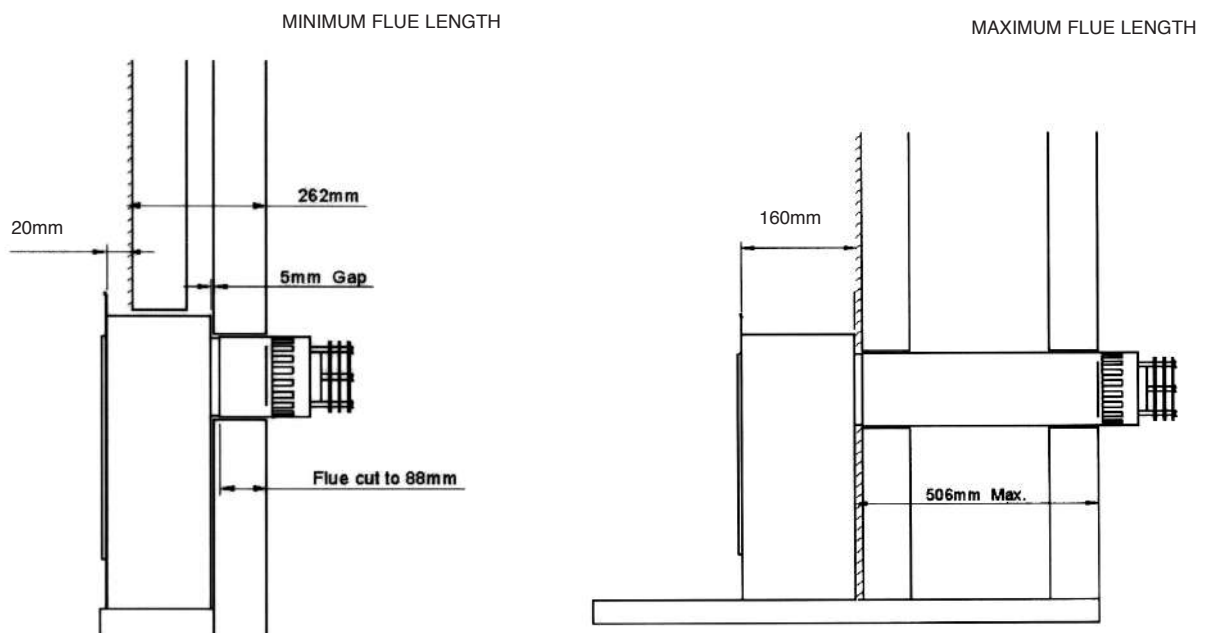

Installation Instructions

Site Requirements

1. Flue & Chimney Requirements

NOTE: This appliance can only be installed in conjunction with the flue supplied.

You must adhere to the following:

- 1.1 The flue must be sited in accordance with BS5440: Part 1 (latest edition), see Diagram 1.
- 1.2 Fit a guard to protect people from any terminal less than 2 metres above any access such as level ground, a balcony or above a flat roof.
- 1.3 The flue must be securely fixed and fire precautions followed in accordance with local and national codes of practice.

- 1.4 The horizontal terminal can be reduced in length, see Diagram 2.

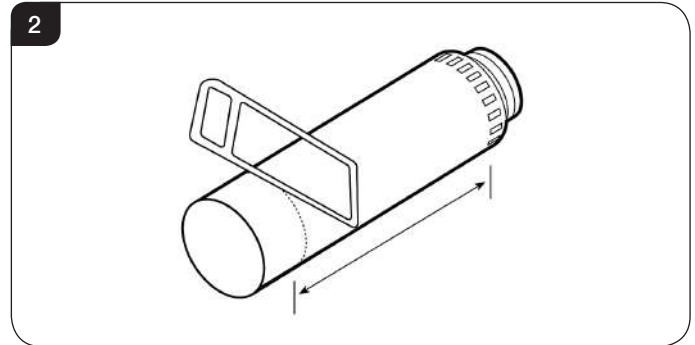

1 UK Dimensions

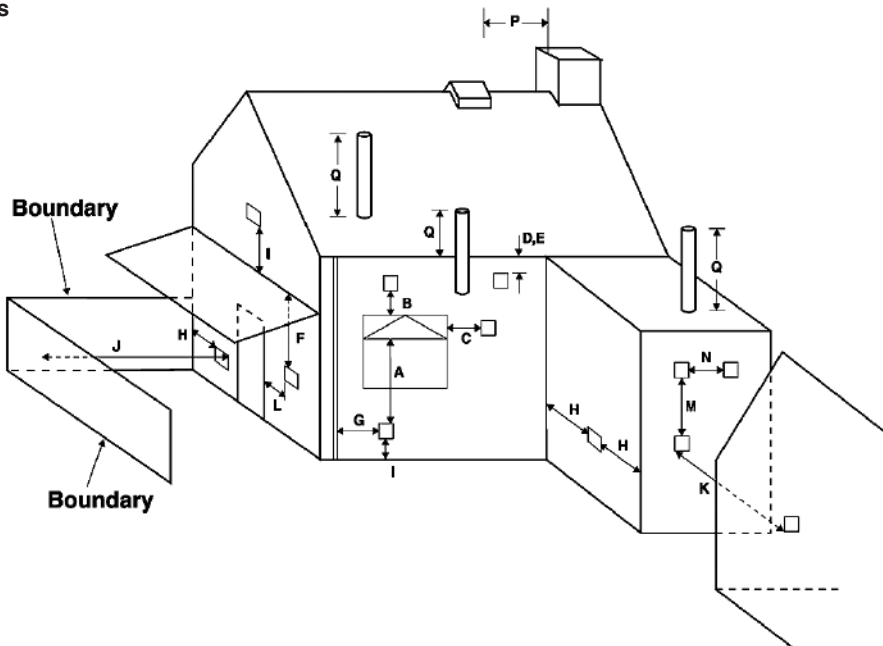

Dimension	Terminal Position	Minimum Distance
A*	Directly below an opening	600mm
B*	Above an opening	300mm
C*	Horizontally next to an opening	400mm
D	Below gutters, soil pipes or drain pipe	300mm
E	Below eaves	300mm
F	Below balcony or car port roof	600mm
G	From a vertical drain pipe or soil pipe	300mm
H	From an internal or external corner or to a boundary alongside the terminal	600mm
I	Above ground, roof or balcony level	300mm

Dimension	Terminal Position	Minimum Distance
J	From a surface or boundary facing the terminal	600mm
K	From a terminal facing the terminal	600mm
L	From an opening in the car port (e.g. door, window) into the dwelling	1200mm
M	Vertically from a terminal on the same wall	1200mm
N	Horizontally from a terminal on the same wall	300mm
P	From a structure on the roof	600mm
Q	Above the highest point of intersection with the roof	300mm

* In addition, the terminal should not be nearer than 300mm to an opening in the building fabric formed for the purpose of accommodating a built-in element such as a window frame.

Installation Instructions

Site Requirements

Timber Framed Buildings

- 1.5 It will be necessary to provide additional clearance when the flue passes through a wall containing any combustible materials so as to prevent a fire hazard.
- 1.6 The hole through which the flue will pass, must have a steel sleeve which is positioned so that an air gap of at least 25mm is maintained between the outer surface of the flue, and any part of the sleeve.
- 1.7 For further guidance on the installation of gas appliances in timber framed buildings, contact your local buildings control authority.

2. Gas Supply

- 2.1 Before installation, ensure that the local distribution conditions (identification of the type of gas and pressure) and the adjustment of the appliance are compatible.
- 2.2 Ensure the gas supply delivers the required amount of gas and is in accordance with the rules in force.
- 2.3 Factory-sheathed/wrapped soft copper tubing with small ridges which allow pipe movement are considered to be a suitable alternative to a pipe sleeve, when recessing the unit into a cavity wall the gas supply is best fed through the wall from the outside. Soft soldered joints can only be used outside the appliance.
- 2.4 This appliance is supplied complete with a factory fitted isolation device incorporated into the inlet connection. No further isolation device is therefore required.

3. Ventilation

- 3.1 This appliance requires no additional ventilation.

4. Appliance Location

NOTE: It is recommended you construct the back panel of the fireplace from natural materials cut into three or more sections to prevent cracking. Resin-based materials may not be suitable. This appliance is an effective heat producer and attention must be paid to the construction and finish of the fireplace.

- 4.1 This appliance must stand on a non-combustible hearth that is at least 12mm thick.
- 4.2 It must be fitted into a non-combustible opening. The minimum dimensions shall be as shown in Diagram 3.

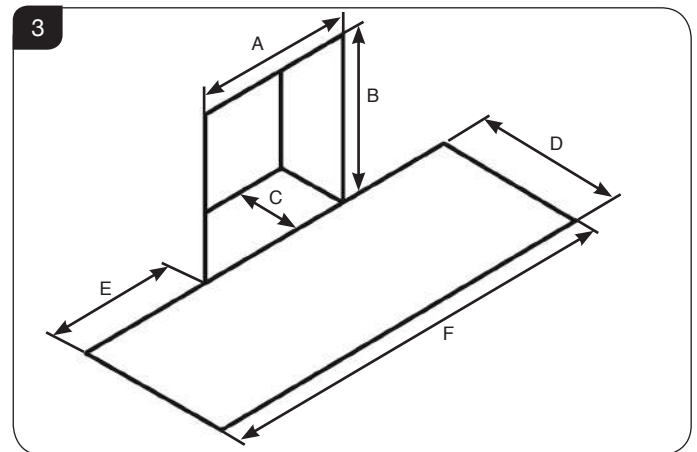

Dimensions	Min	Max
A	420mm	450mm
B	560mm	575mm
C	165mm	-
D	300mm	-
E	150mm	-
F	720mm	750mm

- 4.3 These appliances must be hearth mounted into a fireplace opening conforming to National Standards.
- 4.4 If the appliance is greater than 50mm above the floor, then no hearth is required, although due consideration should be given to how the heat may affect the floor material.

Installation Instructions

Site Requirements

- 4.5 This appliance can only be installed on an outside wall with suitable clearances for the flue terminal and guard (if required).
- 4.6 This appliance is not suitable for installation into a combustible wall. All combustible material must be removed from the area shown, see Diagram 4.

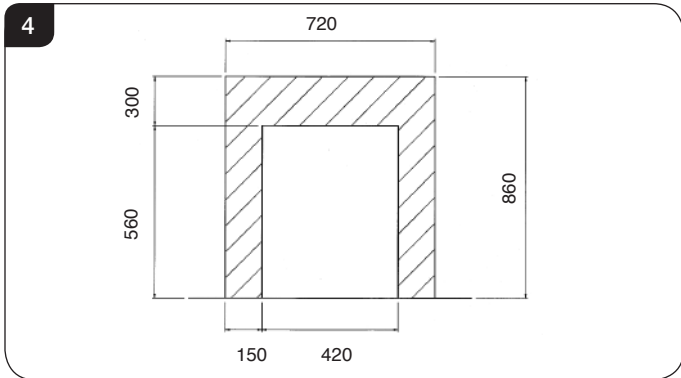

- 4.7 The maximum depth of combustible shelf is 150mm at a minimum height of 300mm above the fireplace opening.

Installation Instructions

1. Safety Precautions

- 1.1 For your own and other's safety, you must install this appliance according to local and national codes of practice. Failure to install the appliance correctly could lead to prosecution. **Read these instructions before installing and using this appliance.**
- 1.2 These instructions must be left intact with the user.
- 1.3 Do not attempt to burn rubbish on this appliance.
- 1.4 Keep all plastic bags away from young children.
- 1.5 Do not place any object on or near to the appliance and allow adequate clearance above the appliance.

IF THE APPLIANCE IS EXTINGUISHED OR GOES OUT IN USE, WAIT 3 MINUTES BEFORE ATTEMPTING TO RELIGHT THE APPLIANCE.



IMPORTANT: REFER TO DATA BADGE AND TECHNICAL SPECIFICATION AT THE FRONT OF THE MANUAL TO ENSURE THE APPLIANCE IS CORRECTLY ADJUSTED FOR THE GAS TYPE AND CATEGORY APPLICABLE IN THE COUNTRY OF USE.

FOR DETAILS OF CHANGING BETWEEN GAS TYPES REFER TO SERVICING, SECTION 10, REPLACING PARTS.

Unpacking

- 1.6 Remove the appliance from its packaging, and check that it is complete and undamaged.

Put the loose ceramic parts to one side so that they are not damaged during installation.

2. Installation of the Gas Supply

For specific gas types and working pressures see Technical Specifications, pages 12 and 13.

TO CHANGE FROM ONE GAS TYPE TO ANOTHER A COMPLETE ENGINE ASSEMBLY AND DATA BADGE WILL BE REQUIRED. SEE SECTION 10 REPLACING PARTS.

- 2.1 Before installation, ensure that the local distribution conditions (identification of the type of gas and pressure) and the adjustment of the appliance are compatible. See Technical Specification on pages 12 and 13.

- 2.2 The position of the gas inlet pipe is shown, see Diagram 1.

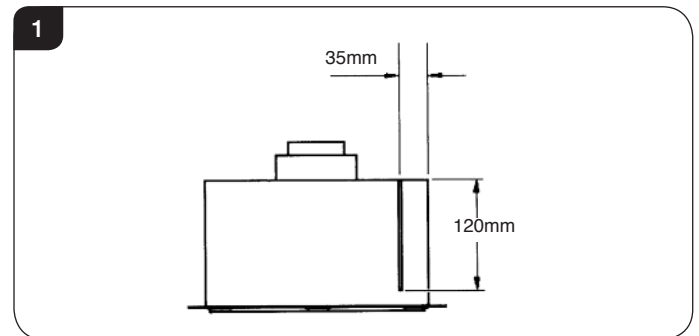

- 2.3 All supply pipes must be purged of any debris that may have entered, prior to connection to the appliance.
- 2.4 The gas supply enters through the silicone panel located on the rear of the outer box. This will need to be slit with a sharp knife prior to passing the supply pipe through.

3. Preparing the Appliance

- 3.1 Remove the backing from the self-adhesive silicone sealing strip and apply to the rear flange of the firebox ensuring that the strip is positioned as close to the outer edge as is practically possible, see Diagram 2, Arrow A.

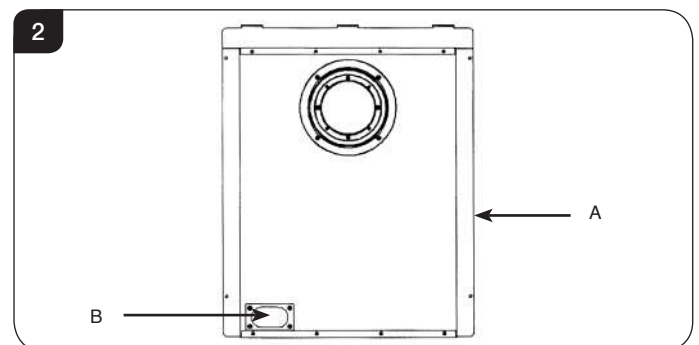

- 3.2 Gas pipe entry must come through the rear right-hand side of the box. The rubber seal must be cut using a sharp knife to allow the isolating elbow to pass through it. Ensure the rubber is not damaged when doing this, see Diagram 2, Arrow B.
- 3.3 A means of isolation is provided with the appliance. This must be fitted to the supply pipe prior to installing the firebox.

Installation Instructions

- 3.4 The appliance can either be recessed into an inner leaf of the wall. A 20mm rebated surround or 20mm thick back panel must be used with this method. Or it can be installed in front of the wall in conjunction with a fire surround constructed of a studwork frame, Diagram 3 for options. **If using a back panel constructed from natural materials such as stone, the panel should consist of 3 or more sections to reduce the risk of cracking.**

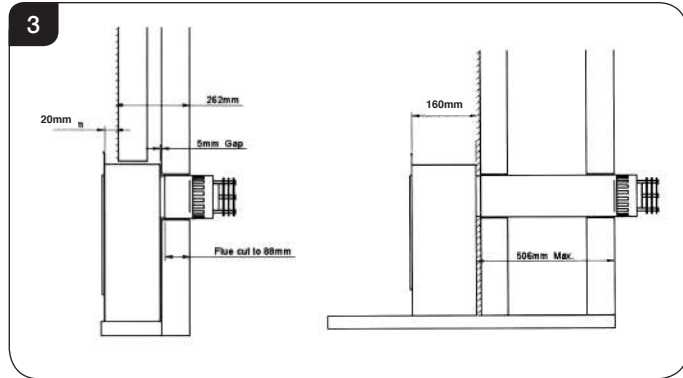

4. Non Recessed Installation

- 4.1 Mark the position of the flue on the inner wall by measuring from the top of the finished hearth level, Diagram 4.

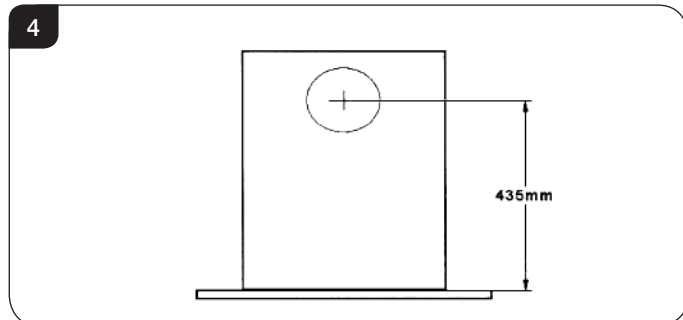

- 4.2 A 152mm (6") diameter hole is required to install the flue.

This can be achieved by either:

- Core drill
- Hammer and chisel.

It is advisable to drill small holes around the circumference when using method b. Make good both ends of the hole.

- 4.3 It will now be necessary to construct a studwork frame to house the appliance. The minimum depth of the aperture must be 165mm. This includes an air gap of 5mm behind the appliance. The sides must be lined with non-combustible material for the full depth of the aperture.
- 4.4 Combustible parts of the studwork frame must not be any closer than the minimum dimensions shown in Diagram 5. These dimensions need to be maintained even if the frame work is protected by non combustible material.

- 4.5 Do not pack the void around or above the appliance with insulation material such as mineral wool.

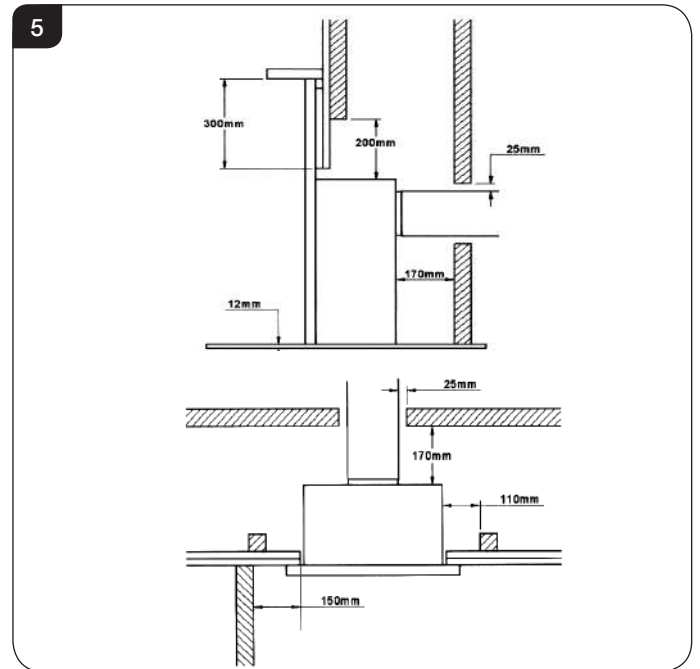

- 4.6 The void into which the appliance is fitted must be ventilated to prevent a build up of heat. If the void is sealed then it will be necessary to fit vents at both low and high levels of approximately 50cm². These vents should take cold air from the room and return warm air back into the room.

5. Recessed Installation

This method of installation requires structural alteration to the intended location. A suitable supporting lintel must be installed to maintain the structural integrity of the surrounding blockwork.

- 5.1 Mark the position of the lintel so that it sits centrally over the intended installation. Remove the blockwork and install the lintel using mortar to ensure a strong bond with the surrounding wall, see Diagram 6.

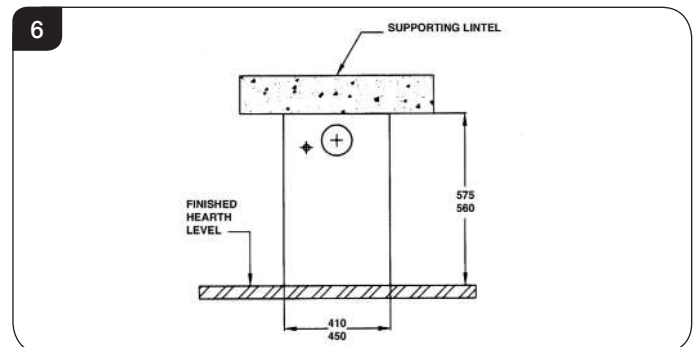

- 5.2 With the lintel in position mark the width of the aperture and remove the blockwork.
- 5.3 Seal the cavity with non combustible board, to prevent any insulation touching the appliance.

Installation Instructions

- 5.4 Ensure that there is a minimum of 10mm gap left between the back of the appliance and the outer wall. **There must be no combustible materials behind this appliance.**
- 5.5 Mark the position of the flue on the wall by measuring from the top of the finished hearth level, see Diagram 7.

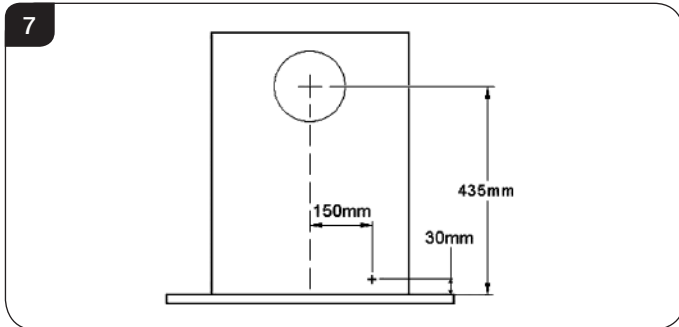

- 5.6 A 152mm (6") diameter hole is required to install the flue.

This can be achieved by either:

- Core drill
- Hammer and chisel

It is advisable to drill small holes around the circumference when using method b. Make good both ends of the hole.

6. Installation of the Appliance

- 6.1 The flue can be cut to length, measure the thickness of the wall the flue is passing through, then deduct 12mm. This is the length required when measuring from the line on the flue label. This must be level with the outside wall face when fitted, see Diagram 8.

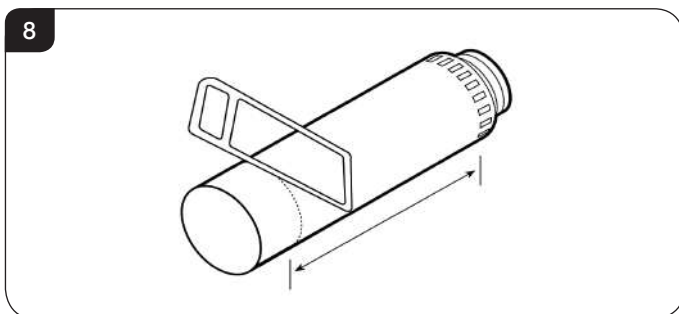

- 6.2 There is a cardboard fitment in the terminal. This is to support the flue whilst it is cut to length. **REMOVE THE REMAINDER OF THE CARDBOARD AFTER CUTTING TO SIZE.**
- 6.3 Remove the compression elbow from the appliance and connect it to the gas supply pipe, taking note of its orientation.

NOTE: TO AID INSTALLATION OF THE GAS PIPE, THE BURNER UNIT CAN BE REMOVED. SEE REPLACING PARTS, SECTION 2.

- 6.4 Attach the flue to the appliance and seal using the aluminium tape provided.
- 6.5 As the appliance is positioned into the opening of the enclosure, pass the flue pipe through the hole in the wall. It will be necessary to pass the supply pipe with the elbow through the silicone panel on the right hand side of the box.
- 6.6 Secure the appliance in place using screws and rawl plugs provided.
- 6.7 **PURGE THE SUPPLY PIPE.** This is essential to expel any debris that may block the gas controls. Connect the elbow to the appliance inlet pipe.
- 6.8 Connect a suitable pressure gauge to the test point located on the inlet elbow and turn the gas on.
- 6.9 Light the appliance and check for leaks.
- 6.10 Turn the appliance to maximum and check that the supply pressure is as stated on the databadge.
- 6.11 Turn the gas supply off and replace the test point screw. Turn the gas on and check the test point for leaks.

Installation Instructions

Foam Seal (Slide Control Models only)

The foam seal must be fitted to the appliance prior to attaching the decorative front.

- 6.12 On the right hand side of the appliance, place the foam seal in the channel between the glass frame and the slide control housing, see Diagram 9.

The foam seal must align with the right hand side of the glass frame and 24mm below the top of the appliance flange, see Diagram 9.

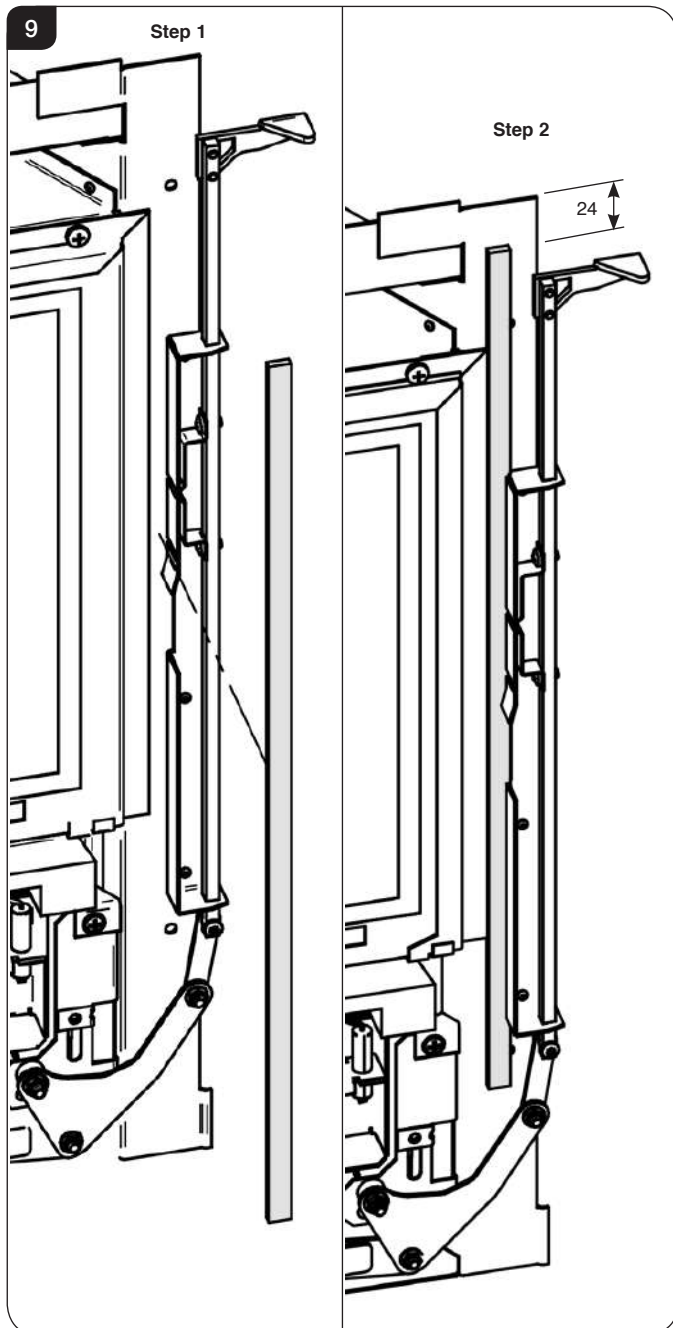

7. Removing the Glass Frame

- 7.1 Remove the glass frame by unscrewing the 2 lower outer pozi head screws, see Diagram 10, Arrow A, by several turns, there is no need to fully remove these 2 screws.
- 7.2 Remove the remaining 6 screws, see Diagram 10, Arrow B.

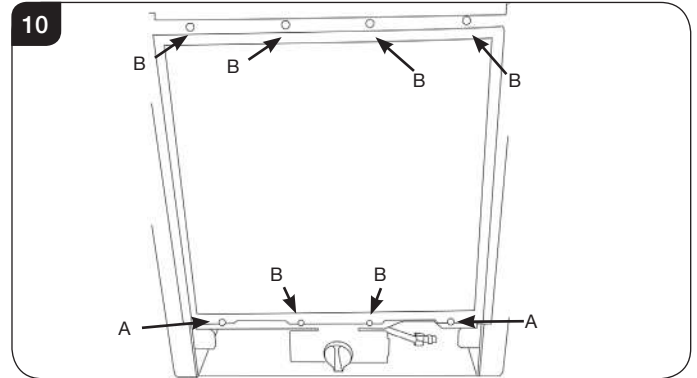

- 7.3 Lift the glass frame clear of the appliance and carefully place to one side.

8. Arrangement of the Fuel Bed

Advice on handling and disposal of fire ceramics



The fuel effect and side panels of this appliance are made from Refractory Ceramic Fibre (RCF), a material which is commonly used for this application.

Protective clothing is not required when handling these articles, but we recommend you follow normal hygiene rules of not smoking, eating or drinking in the work area and always wash your hands before eating or drinking.

To ensure that the release of RCF fibres are kept to a minimum, during installation and servicing a HEPA filtered vacuum is recommended to remove any dust accumulated in and around the appliance before and after working on it. When servicing the appliance it is recommended that the replaced items are not broken up, but are sealed within heavy duty polythene bags and labelled as RCF waste.

RCF waste is classed as stable, non-reactive hazardous waste and may be disposed of at a licensed landfill site.

Excessive exposure to these materials may cause temporary irritation to eyes, skin and respiratory tract; wash hands thoroughly after handling the material.

Installation Instructions

8A. White Stone Layout

ONLY USE THE CORRECT TYPE AND QUANTITY OF WHITE STONES. ALWAYS FOLLOW THE FUEL BED LAYOUT AS STATED IN THESE INSTRUCTIONS. NEVER CHANGE THE LAYOUT FROM THAT SHOWN HERE.

- 8.1 Arrange the white stones in the areas highlighted in Diagram 11. They should be evenly distributed.

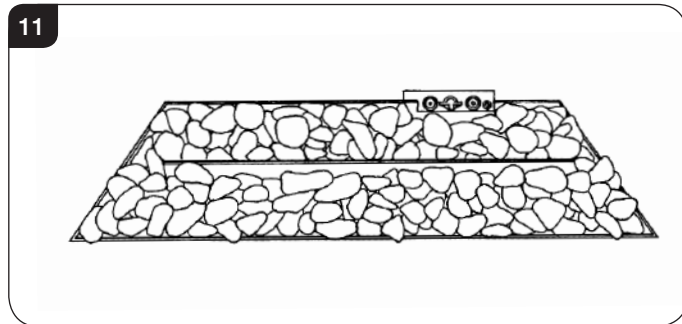

- 8.2 Lean the white stones against the burner ledges to disguise the ledges, see Diagram 12.

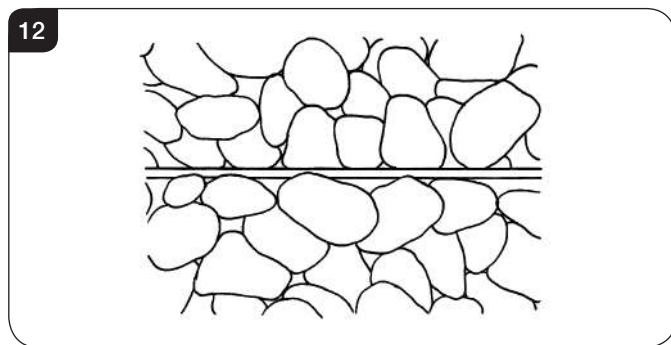

- 8.3 Check that the port area, see Diagram 13, Arrow A is clear of white stones. This can be easily done by gently running a screwdriver or similar object along this area.

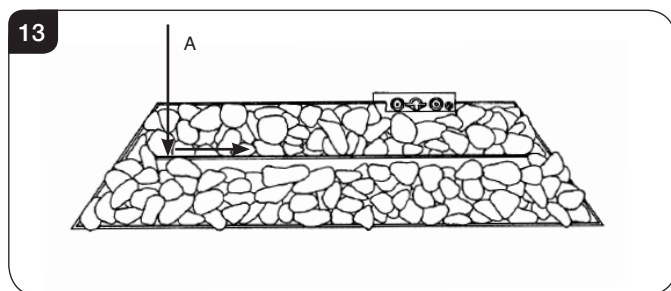

NOTE: IT IS IMPORTANT THE WHITE STONES DO NOT COVER THE PORT AREA IN BETWEEN THE BURNER LEDGES.

- 8.4 Ensure that no stones overhang or fill the pilot area, see Diagram 14, Arrow B.

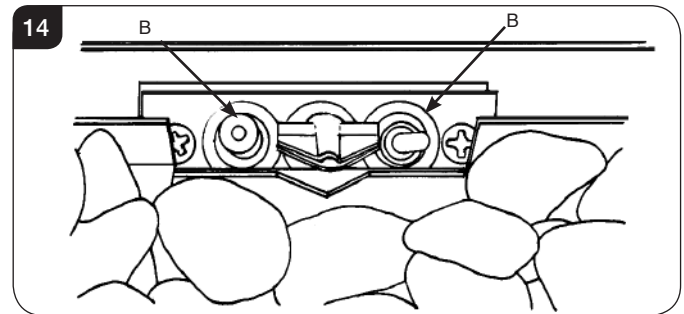

NOTE: STONES SHOULD NOT BE PLACED DIRECTLY IN FRONT OF THE PILOT CROSS LIGHTING FLAME.

8B. Coal Effect Layout

NOTE: CERAMIC PARTS ARE FRAGILE. HANDLE WITH CARE. ONLY USE THE CORRECT TYPE AND QUANTITY OF CERAMIC COMPONENTS.

- 8.5 Place the rear panel against the rear of the box resting on the shelf.
- 8.6 Slide one of the side panels into the box ensuring it touches the rear panel.
- 8.7 Gently ease the front edge of the side panel behind the flange so it lies flat against the wall of the box.
- 8.8 Repeat with the second side panel, see Diagram 15.

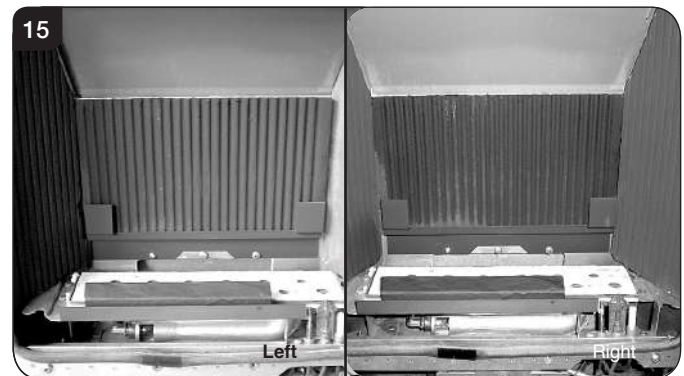

- 8.9 Locate the top panel on top of the sides and rear by lifting it up and forward inside the box.
- 8.10 Slide it backwards and down behind the side panels to rest on the rear panel, see Diagram 16.



Installation Instructions

- 8.11 Position the flame baffle centrally on the tray and ensure the stepped lower edge engages against the rear edge of the burner skin, see Diagram 17.



- 8.12 Place the front coal centrally in the channel at the front of the tray. The relationship between the front coal and the flame baffle is shown, see Diagram 18.



- 8.13 There are three sizes of coal used. Small x3, medium x4 and large x1. For identification, see Diagram 19.

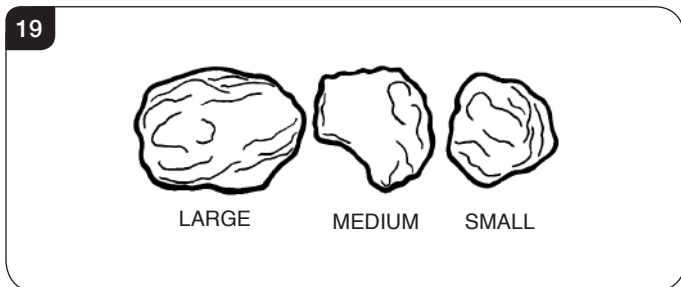

- 8.14 Place the single large coal in the central dent of the front coal resting against the flame baffle, see Diagram 20.

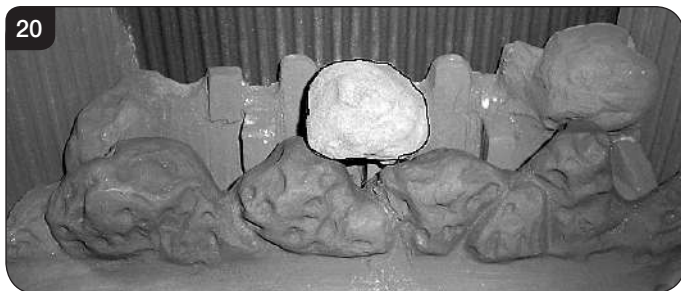

- 8.15 Place the left front medium coal in the recess between the flame baffle and the front coal, see Diagram 21.



- 8.16 Place the front right medium coal on the front coals and against the flame baffle, see Diagram 22.



- 8.17 Place the rear left medium coal on the recess behind the front row of coals resting on the rear panel, see Diagram 23.



- 8.18 Place the rear right medium coal in the recess behind the front row of coals resting on the rear pane, see Diagram 24.



Installation Instructions

- 8.19 Place the right hand small coal in the recess between the flame baffle and the front coal, see Diagram 25.



- 8.20 Place the left hand small coal in the recess between the flame baffle and the front coal, see Diagram 26.



- 8.21 Place the centre rear small coal in the recess behind the large centre coal, see Diagram 27.



- 8.22 It is essential that gaps are left between the coals to maximise the performance of the appliance.

9. Fitting the Glass Frame

- 9.1 Ensure that the fibre glass seal on the box is intact, then lower the glass frame onto the 2 lower fixing screws, see Diagram 28, Arrow A.
- 9.2 Fit the other 6 fixing screws, see Diagram 28, Arrow B.
- 9.3 Tighten all 8 screws to secure the frame, Diagram 28. Replace ALL of the securing screws ensuring that a screw is present in all fixing slots.

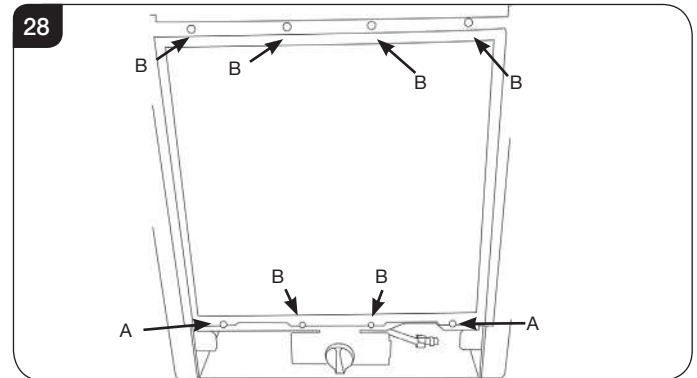

NEVER OPERATE THE APPLIANCE WHEN THE GLASS FRAME IS REMOVED OR BROKEN.

Refer to the separate decorative front Instructions to replace the front on the appliance.



UNDER NO CIRCUMSTANCES SHOULD THE APPLIANCE BE USED IF ANY OF THE GLASS FRAME RETAINING SCREWS ARE LOOSE OR MISSING.

10. Operating the Appliance

- 10.1 There are three types of control systems available for this appliance:

1. Manually Operated Control
2. Remote Control
3. Slide Control

Follow the relevant section for specific operation.

Manual Control

- 10.2 Locate the control valve on the appliance. It has a single manual control, see Diagram 29:

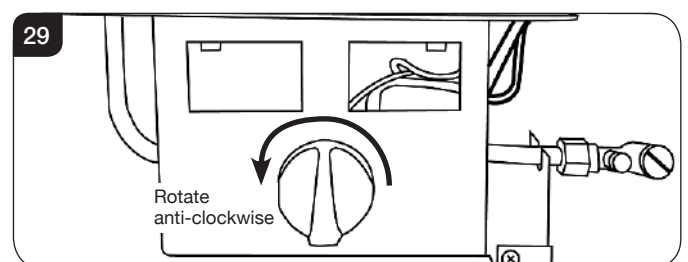

Installation Instructions

Lighting the Pilot

10.3 Push the valve knob in and rotate anti-clockwise slowly until a click is heard.
The pilot should now be lit.

10.4 Hold in for a further 10 seconds.
When released the pilot should remain lit.

If the pilot does not remain lit, repeat until the operation is successful.

Locating the Pilot

Coal Effect

The pilot is located on the front right hand side of the appliance. To view the pilot look down through the GAZCO logo between the glass and the front coal, Diagram 30.

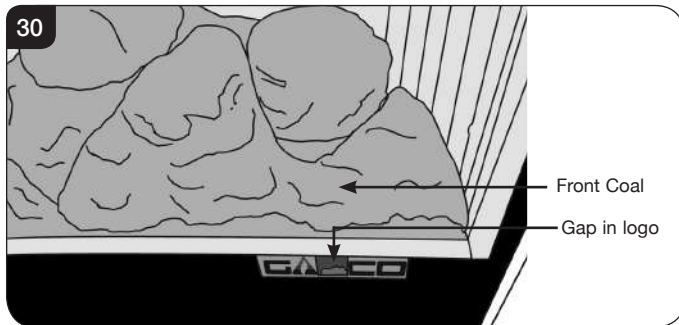

White Stone Effect

The pilot is located on the rear right hand side of the appliance and is clearly visible when lit, see Diagram 31.

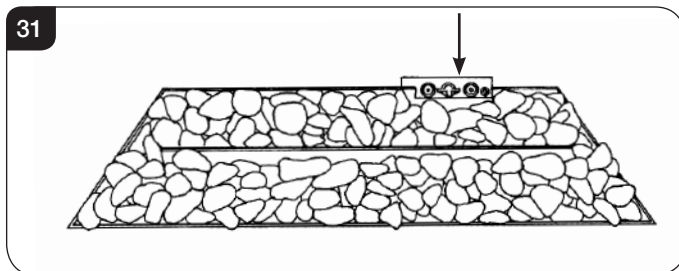

Adjusting the Flame height

10.5 From the pilot position push the valve knob in slightly and rotate anti-clockwise until the first stop point is felt.

This denotes the lowest setting.

10.6 Push the valve knob in slightly and rotate further in an anti-clockwise direction.

The final stop point is the highest setting.

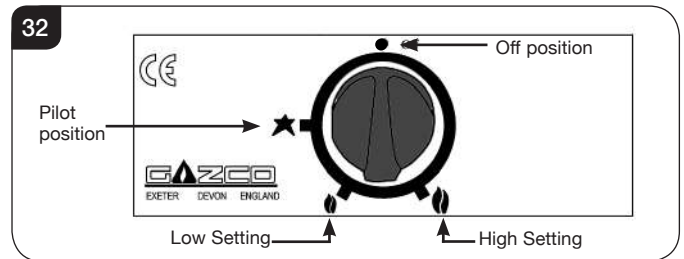

i **IMPORTANT: YELLOW FLAMES TYPICALLY APPEAR WHEN THE APPLIANCE HAS REACHED NORMAL OPERATING TEMPERATURE. THIS CAN TAKE UP TO 30 MINUTES.**

! **WARNING: IF THE APPLIANCE FAILS TO LIGHT OR BECOMES EXTINGUISHED IN USE, WAIT 3 MINUTES BEFORE ATTEMPTING TO RELIGHT.**

Switching OFF the Appliance

10.7 To switch the appliance off turn the control knob clockwise until it is returned to the off position, see Diagram 33.

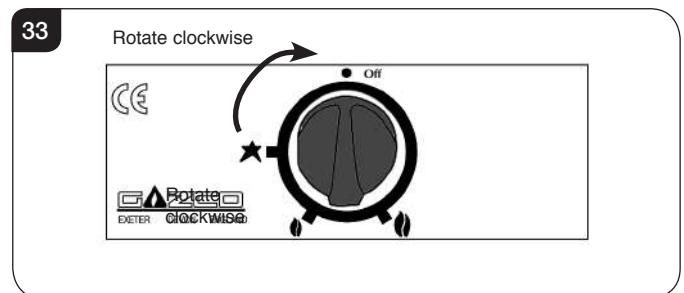

The knob should be upright.

Installation Instructions

Remote Control

The pilot on Remote Control appliances must be lit manually from the valve unit before operation.

The control valve is at the foot on the right-hand side of the appliance. It has two controls, see Diagram 34:

1. The right-hand knob controls the pilot ignition.
2. The left-hand knob controls the main burner.

Lighting the Pilot

- 10.8 To start the left-hand and right-hand control knobs must both point to off (●):

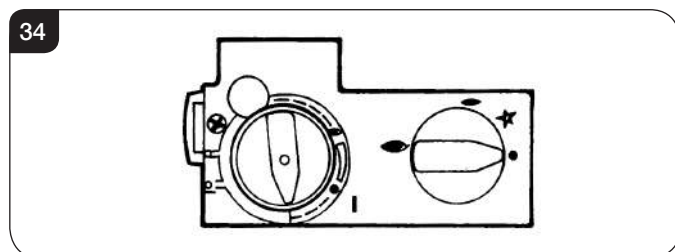

- 10.9 Press in the right-hand control knob and rotate anti-clockwise until a click is heard. Continue to press in. The knob points to the pilot (←).

The pilot is lit.

- 10.10 Keep the knob depressed for 10 seconds before releasing. The pilot remains lit.

Repeat the above steps if the pilot does not stay lit.

NOTE: If the pilot goes out, the Interlock system prevents you lighting again for a short period.

- 10.11 If, after repeating the above steps the pilot does not light, contact your Retailer or Installer.
- 10.12 Turn the right-hand control to point to main burner (↗). The appliance can now be controlled by the remote handset.
- 10.13 The Standard remote controls the appliance when:
- the pilot is lit.
 - the right-hand control points to main burner ↗ ready to operate position.

It regulates the temperature from low to high and back. It can also turn the main burner off leaving just the pilot burning and ready to operate.

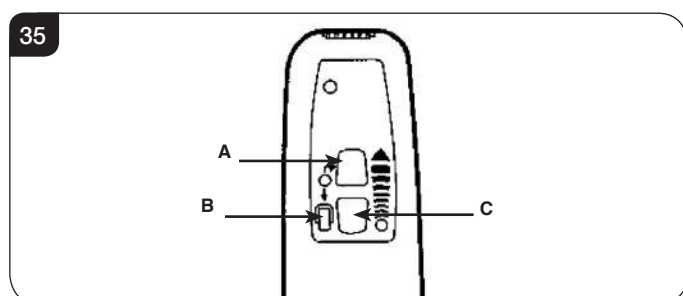

To light the main burner:

- 10.14 Press buttons A & B simultaneously. The remote's LED light flashes to show communication between the appliance's controls and the remote.

Adjusting the Flame height:

- 10.15 Press and hold buttons A & B simultaneously to increase the flame height. A clicking sound indicates that the appliance is at maximum.
- 10.16 Press and hold button C to decrease the flame height. Continue to press C to turn off the main burner.

To make small adjustments to flame height:

- 10.17 Press and hold down button B and press button A once to make a slight increase. This increases the temperature by stages.
- Repeat to further adjust.
- 10.18 Press button C once to slightly reduce the flame height.



IMPORTANT: YELLOW FLAMES TYPICALLY APPEAR WHEN THE APPLIANCE HAS REACHED NORMAL OPERATING TEMPERATURE. THIS CAN TAKE UP TO 30 MINUTES.



WARNING: IF THE APPLIANCE FAILS TO LIGHT OR BECOMES EXTINGUISHED IN USE, WAIT 3 MINUTES BEFORE ATTEMPTING TO RELIGHT.

Switching OFF the Appliance

THE REMOTE CONTROL CAN TURN THE MAIN BURNER OFF AND LEAVE THE PILOT BURNING AND READY TO OPERATE ↗.

- 10.19 To switch off the appliance completely (no pilot burning) return both control knobs to the off position (●).

Remote Control

- 10.20 To turn the main burner of the appliance off using the handset press and keep pressing the Off button (●).

The main burner goes out leaving the pilot burning and ready to run ↗.

Controls on Appliance

- 10.21 Use the controls on the appliance to turn the appliance off by turning the left-hand control knob until it points to Off (●). A click is heard and the main burner goes out leaving the pilot burning and ready to run ↗.

CAUTION: IN RARE INSTANCES, NOISES FROM SOURCES OUTSIDE THE REMOTE CAN OPERATE THE MAIN BURNER. IF THIS OCCURS, ALWAYS TURN THE CONTROL TO PILOT (↗) OR OFF.

Installation Instructions

Slide Control

This appliance is operated using the slide control on the top right hand side of the decorative front.

When the appliance is OFF the slide control will be at the highest point, see Diagram 36.

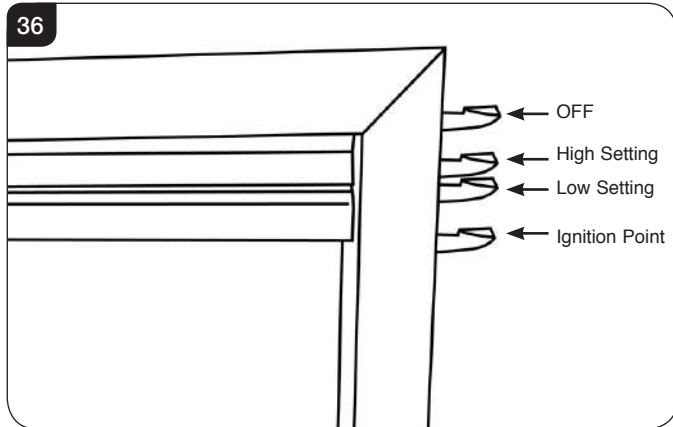

Lighting the Pilot

10.22 Push the slide control down as far as possible to its lowest point, see Diagram 36, this is the ignition point.

Keep the slide control pressed down for 5 seconds to ensure the pilot is lit. Then release.

The appliance should light on its lowest setting.

10.23 When released the slide control automatically raises to a natural stop point, see Diagram 36.

Repeat the above steps if the appliance does not light.

10.24 If, after repeating the above steps the pilot does not light, contact your Retailer or Installer.

Adjusting the Flame height

10.25 Increase the flame height and temperature by carefully moving the slide control up until the next stop point is felt, see Diagram 36. This denotes the highest setting.

10.26 Carefully move the slide control down to the lower stop point to return to the lowest setting.

i **IMPORTANT: YELLOW FLAMES TYPICALLY APPEAR WHEN THE APPLIANCE HAS REACHED NORMAL OPERATING TEMPERATURE. THIS CAN TAKE UP TO 30 MINUTES.**

! **WARNING: IF THE APPLIANCE FAILS TO LIGHT OR BECOMES EXTINGUISHED IN USE, WAIT 3 MINUTES BEFORE ATTEMPTING TO RELIGHT.**

Switching OFF the Appliance

10.27 To turn the appliance off lift the slide control to its highest stop point, see Diagram 36. The pilot goes out.

1. Commissioning

- 1.1 Complete the Commissioning Checklist at the front of this manual covering:
 - Thermocouple soundness checks.
This is to include ensuring the thermocouple is secure on the pilot bracket assembly, lead connection and integrity.
 - Flue checks
 - Gas checks
 - Fuel effect layout - flame picture
- 1.2 Upon completion of the commissioning and testing of the installation and correct operation of the appliance, the installer must instruct the user how to operate the appliance.
- 1.3 Guide the user through the User Instructions paying particular attention to:
 - a) Regular servicing (Section 8 of the User Instructions).
 - b) Ventilation (Section 9 of the User Instructions) - point out the ventilation positions where applicable.
 - c) Hot surfaces (Section 11 of the User Instructions).

Servicing Instructions

Servicing/Fault Finding Charts

1. Servicing Requirements

IMPORTANT – The glass panel on this appliance should be checked for any signs of damage on the front face of the glass panel (scratches, scores, cracks or other surface defects). If damage is observed, the glass panel must be replaced and the appliance must not be used until a replacement is installed. Under no circumstances should the appliance be used if any damage is observed. Please isolate the appliance until a replacement glass panel has been obtained and installed. Replacement glass panels can be purchased from Gazco via the retailer from which the appliance was purchased or any other Gazco distributor.

This appliance must be serviced at least once a year by a competent person.

All tests must be carried out in accordance with the current GasSafe recommendations.

1.1 Before Testing:

- Conduct a gas soundness test for the property ensuring there are no leaks before servicing.
- Check the operation of the appliance before testing.

1.2 Special checks:

- Clean the burner using a vacuum cleaner with a soft brush attachment. Ensure all debris is removed from the burner ports.
- Check the flue terminal position complies with the requirements, and that the terminal is not obstructed.
- Clean away any debris under the burner.
- Check the condition of ceramics, pilot and burner cover gasket.
- Ensure that the glass frame is secured correctly and that all retaining screws are in place.

1.4 Correct any faults found during the initial tests

1.5 Re-commission the appliance in accordance with Commissioning Procedures of these instructions.

1.6 Advise the customer of any remedial action taken.

IGNITION FUNCTIONAL CHECK 1

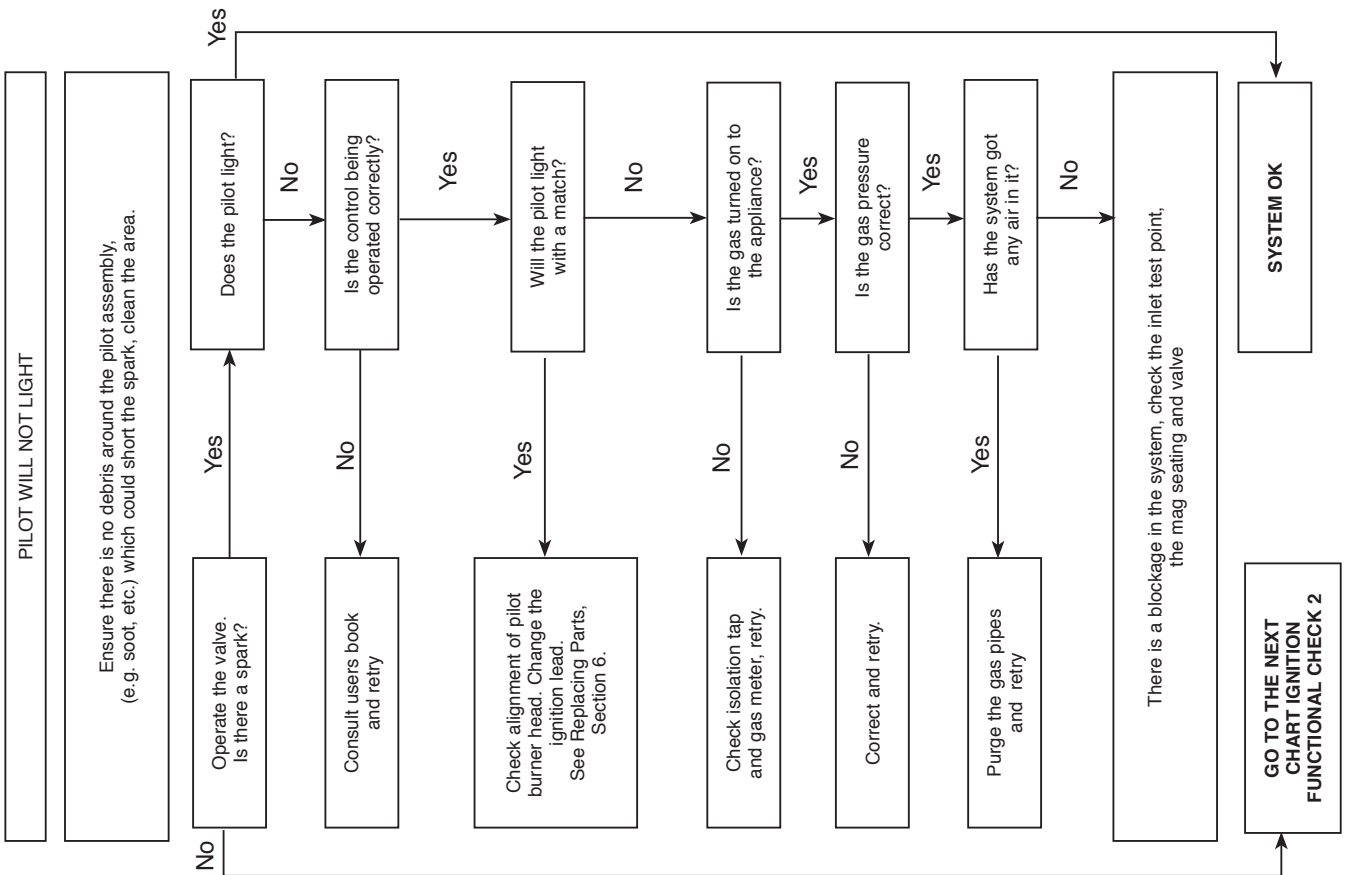

Servicing Instructions

Fault Finding Charts

IGNITION FUNCTIONAL CHECK 2B SLIDE CONTROL

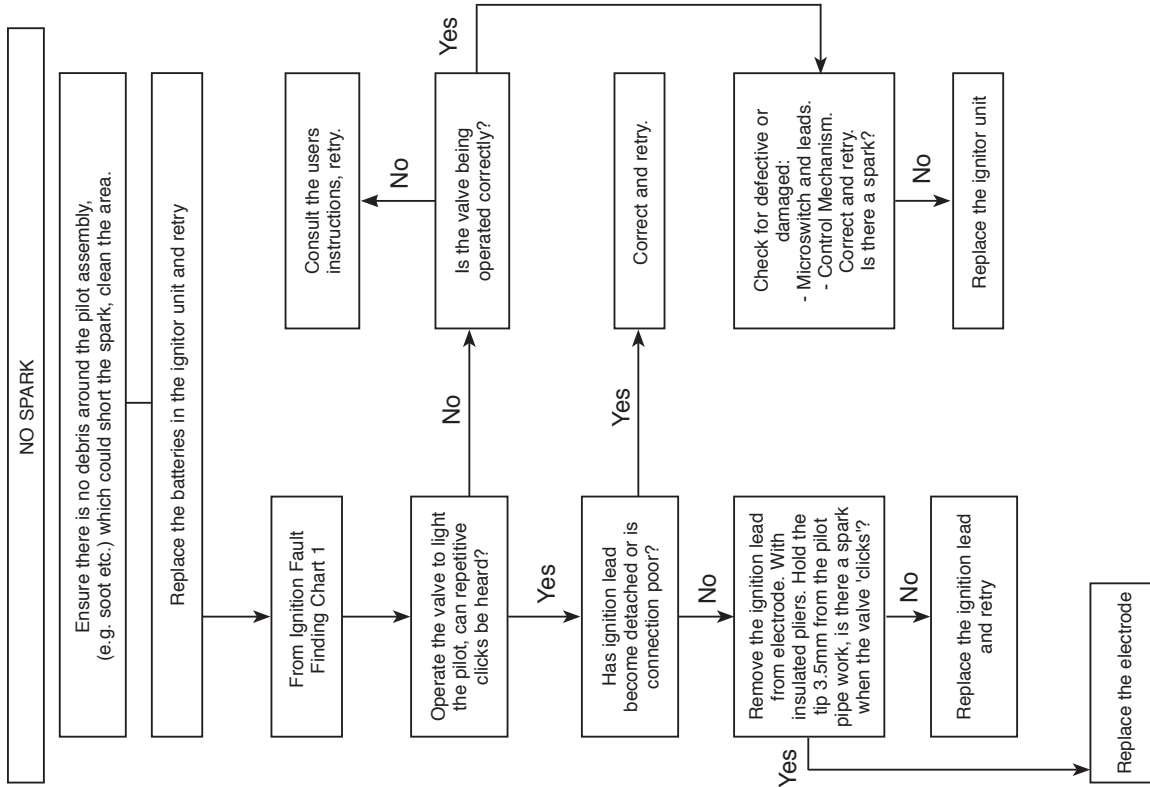

IGNITION FUNCTIONAL CHECK 2A MANUAL & REMOTE

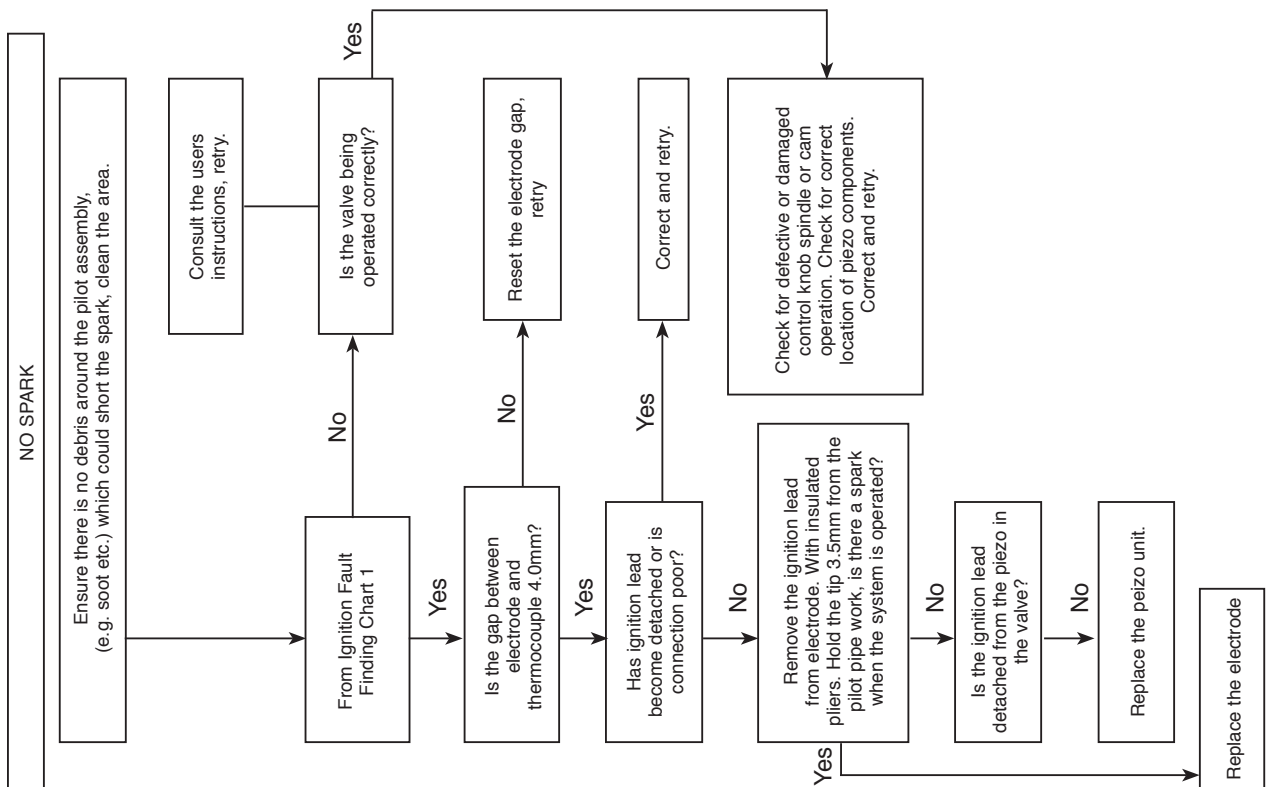

Servicing Instructions

Fault Finding Charts

FLAME FAILURE FUNCTIONAL CHECK 3

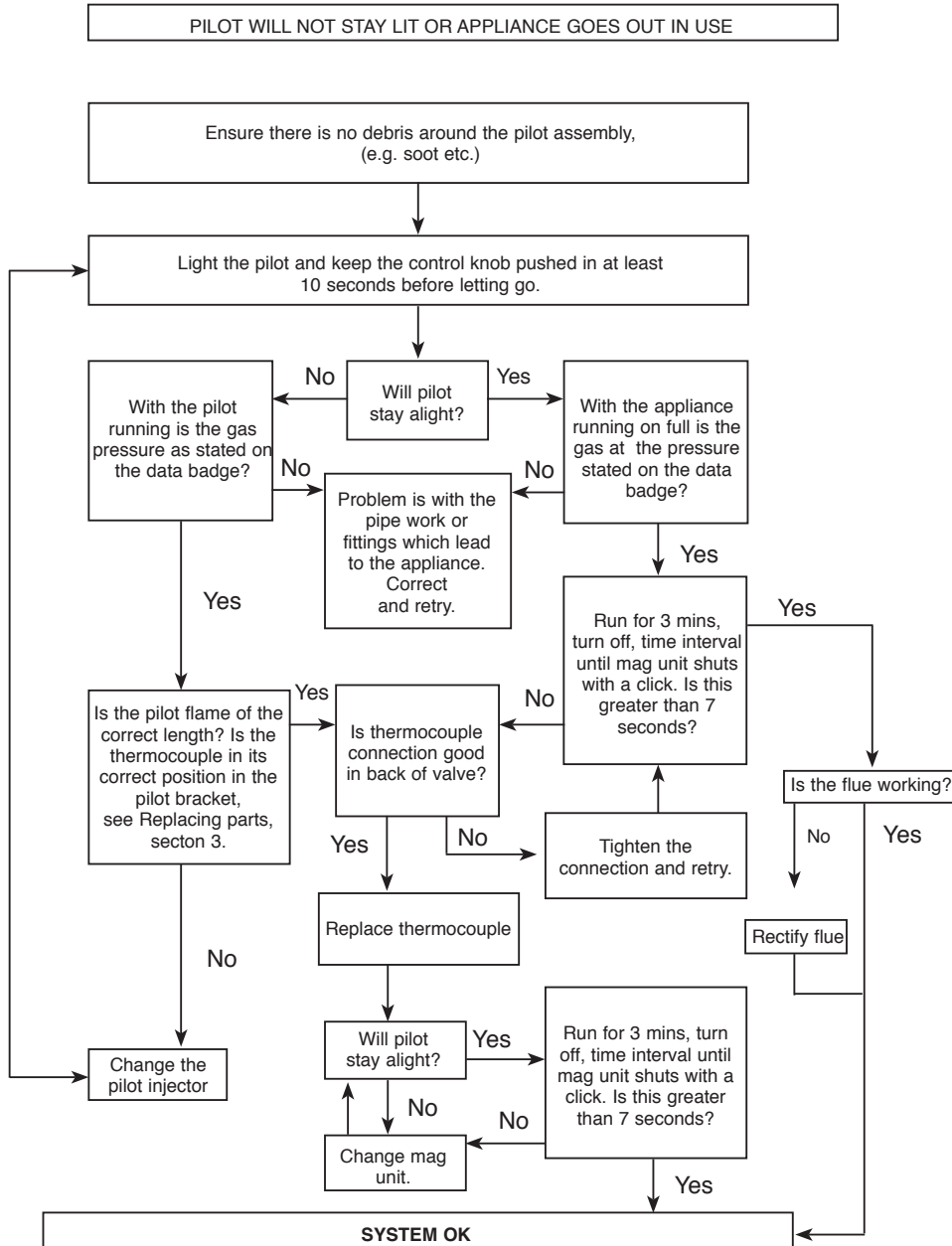

Servicing Instructions - Replacing Parts

1. General

- 1.1 All principal components can be replaced without removing the appliance from its installation, although it is essential that the gas supply to the appliance is turned off at the isolation device before proceeding further.
- 1.2 Before replacing some of the components it will first be necessary to remove the burner assembly from the appliance by following the instructions below.
- 1.3 If for any reason the flue has to be removed from the appliance, the seal must be replaced in the inner spigot.

2. Removing the Burner Unit

Ensure the appliance is cold before proceeding.

- 2.1 Turn the gas supply off at the isolation device. Then disconnect the supply pipe.
- 2.2 Remove the decorative front from the appliance by referring to the separate instructions supplied.
- 2.3 Remove the glass frame by unscrewing the 2 lower outer screws, see Diagram 1, Arrow A, by several turns, there is no need to fully remove these 2 screws.
- 2.4 Remove the remaining 6 screws, see Diagram 1, Arrow B.

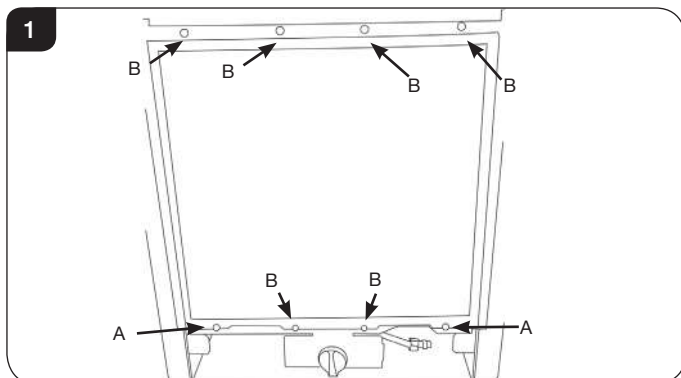

- 2.5 Lift the glass frame clear of the appliance and carefully place to one side.
- 2.6 The glass frame must be refitted to the appliance following cleaning or servicing. Ensure that the fibre glass seal on the box is intact, then lower the glass frame onto the 2 lower fixing screws, see Diagram 1, Arrow A.
- 2.7 Fit the other 6 fixing screws, see Diagram 1, Arrow B.
- 2.8 Tighten all 8 screws to secure the frame, see Diagram 1. Replace ALL of the securing screws ensuring that a screw is present in all fixing slots.

NEVER OPERATE THE APPLIANCE WHEN THE GLASS FRAME IS REMOVED OR BROKEN.

Refer to the separate decorative front instructions to replace the front on the appliance.



UNDER NO CIRCUMSTANCES SHOULD THE APPLIANCE BE USED IF ANY OF THE GLASS FRAME RETAINING SCREWS ARE LOOSE OR MISSING.

- 2.9 Remove the white stones (Stone Effect) or ceramic coals and liners (Coal Effect) and place on a clean dry surface.
- 2.10 Remove glass frame seal from the appliance. Push the arrow-headed spring clips out of the body. It may be necessary to slightly compress the clips to ease removal, see Diagram 2, Detail A.

NOTE: Only the lower seven clips need to be removed.

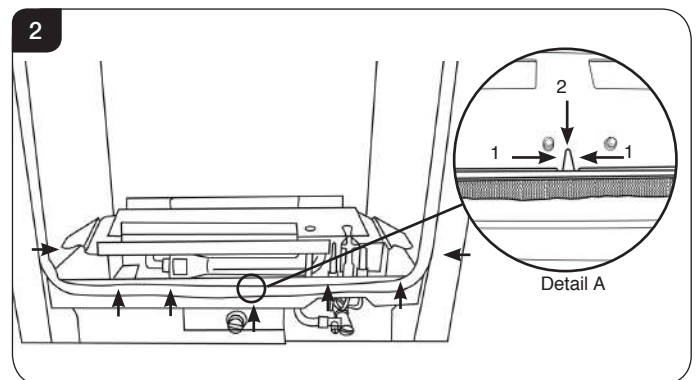

- 2.11 Fully remove the 2 lower outer fixing screws from the appliance, see Diagram 1, Arrow A.

Manual Control

- 2.12 Remove the lower screw positioned centrally below the control valve knob, see Diagram 3.

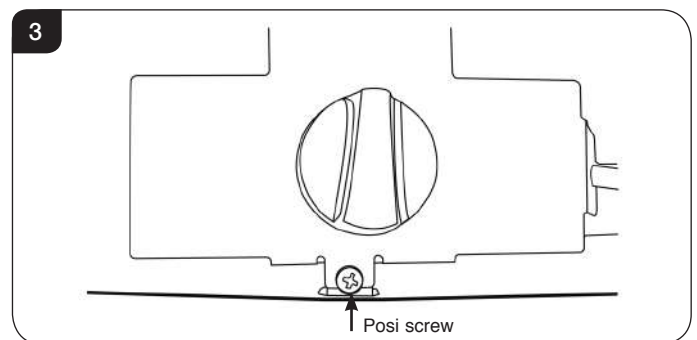

- 2.13 The burner unit can now be removed from the appliance, see 2.20.

Remote Control

- 2.14 Remove the battery before carrying out work on this appliance.

The battery box is located at the bottom left of the appliance behind the ash cover.

- 2.15 The burner unit can now be removed from the appliance, see 2.20.

Servicing Instructions - Replacing Parts

Slide Control

- 2.16 Remove the battery before carrying out work on this appliance.

The appliance battery is located at the bottom left of the appliance behind the ash cover, see Diagram 4.

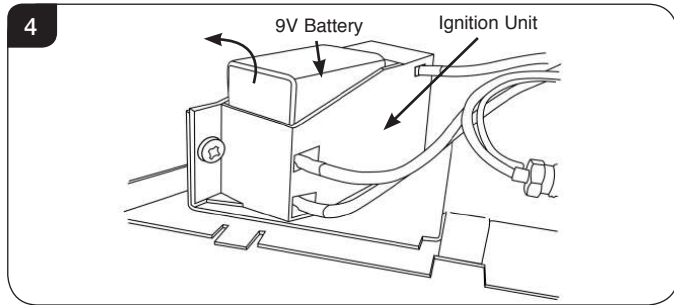

- 2.17 Remove the 2 lower screws positioned either side of the control valve bracket, see Diagram 5.

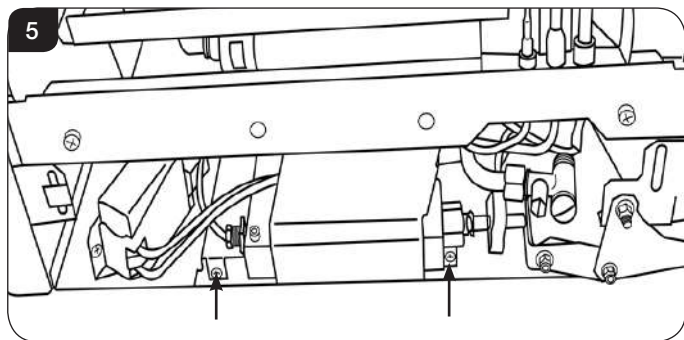

- 2.18 Remove the M4 lock nut and spacer securing the slider arm to the appliance, see Diagram 6. Ensure that the spacer is retained and replaced when the burner unit is reassembled.

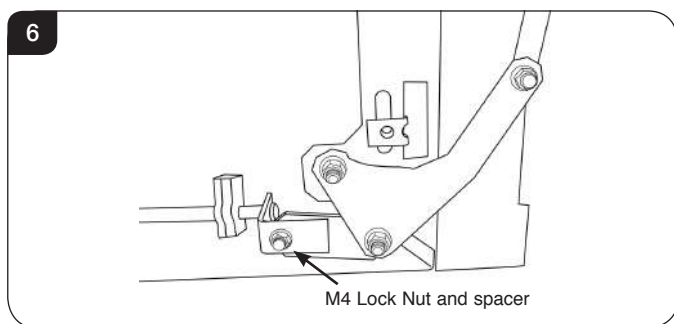

- 2.19 The burner unit can now be removed from the appliance, see 2.20.

Take care not to catch the slide mechanism when removing the burner.

All Models

- 2.20 The burner unit can now be removed from the appliance. Lift the front of the assembly up and out from the appliance. Take care not to damage the door seal.
- 2.21 Replace in reverse order.
- 2.22 When refitting the burner unit, ensure the rear of the tray slides under the retaining bracket on the rear of the appliance, see Diagram 7.

NOTE: The burner unit and pipe work have been removed for clarity.

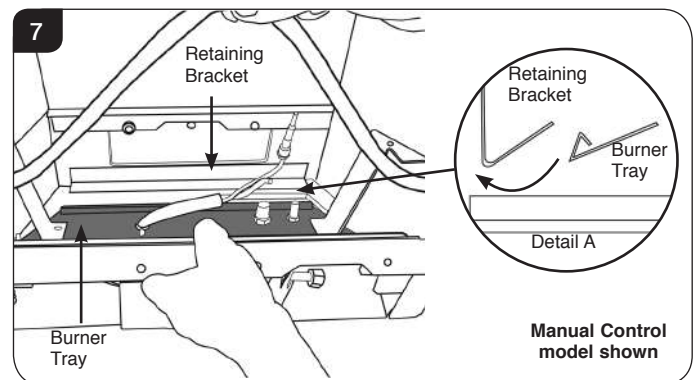

3. Pilot Unit

IMPORTANT: UNDER THE TERMS OF THE EXTENDED WARRANTY IT WILL BE COMPULSORY TO CHANGE THE COMPLETE PILOT UNIT ON THIS APPLIANCE IN YEARS 2 AND 4.

The pilot unit assembly consists of three components which can be individually changed, these are:-

- 3a. Pilot Injector
- 3b. Electrode
- 3c. Thermocouple

3a. Pilot Injector - Stone Effect

- 3.1 Undo the pilot pipe from the bulkhead fitting and from the underside of the pilot unit, see Diagram 8.

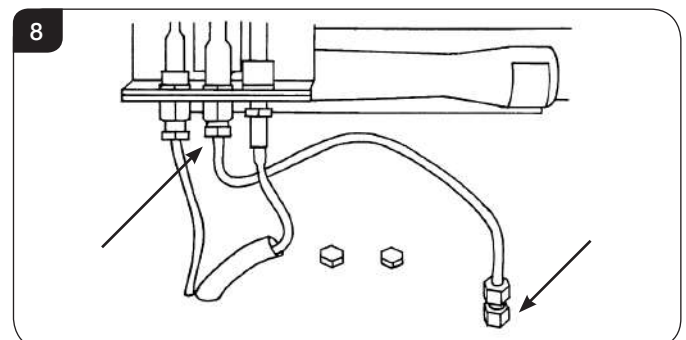

- 3.2 Remove the pipe and the injector drops out from the pilot unit. Take care not to lose or damage the injector.

Servicing Instructions - Replacing Parts

3.3 Replace in reverse order and check for gas leaks.

3a. Pilot Injector - Coal

3.4 Undo the pilot pipe from the valve and from the under side of the pilot unit, see Diagrams 9, 10 or 11.

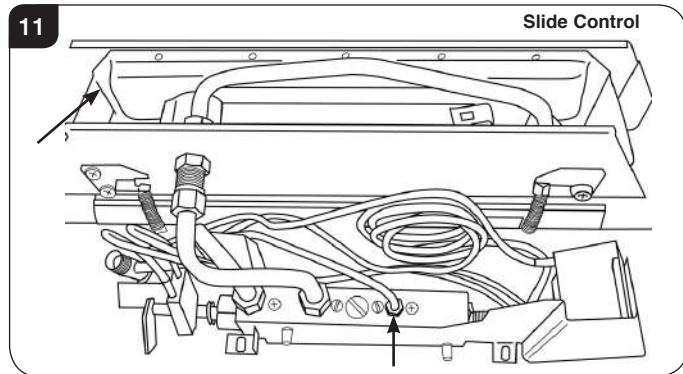
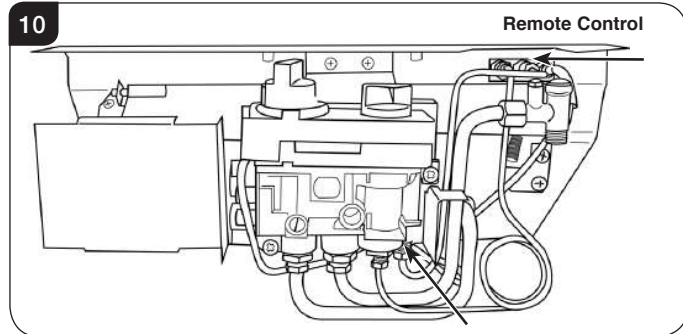
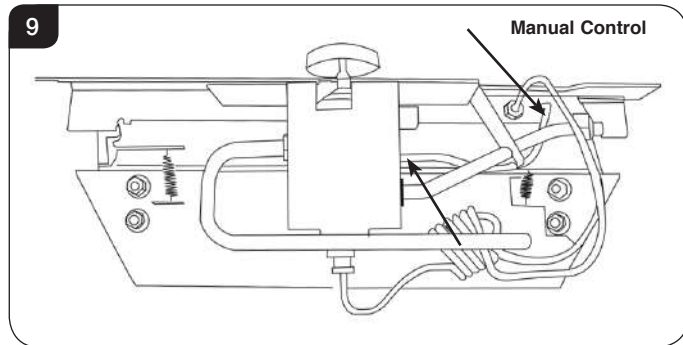

3.5 Remove the pipe and the injector drops out from the pilot unit. Take care not to loose or damage the injector.

3.6 Replace in reverse order and check for gas leaks.

3b. Electrode

3.7 Pull the ignition lead from the electrode and undo the retaining nut, see Diagram 12.

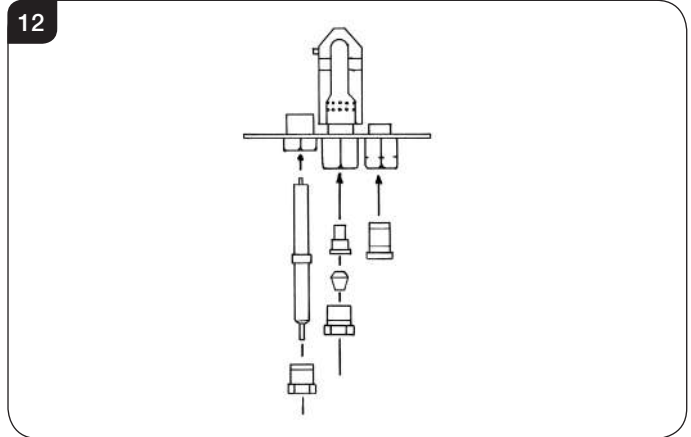

3.8 Replace with new electrode. Do not over tighten the nut as this could break the new component.

3.9 Replace the ignition lead.

3.10 Replace in reverse order.

3c. Thermocouple

3.11 Disconnect the thermocouple from the gas valve, see Diagram 13, 14 or 15.

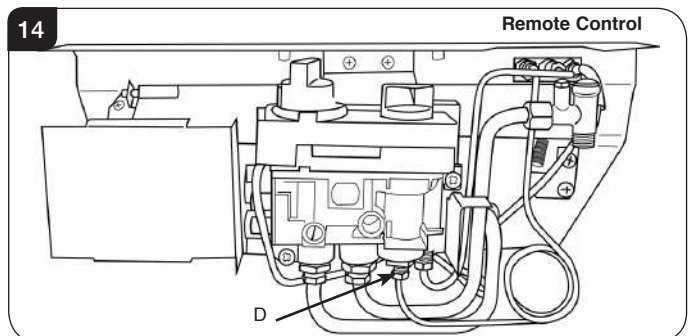
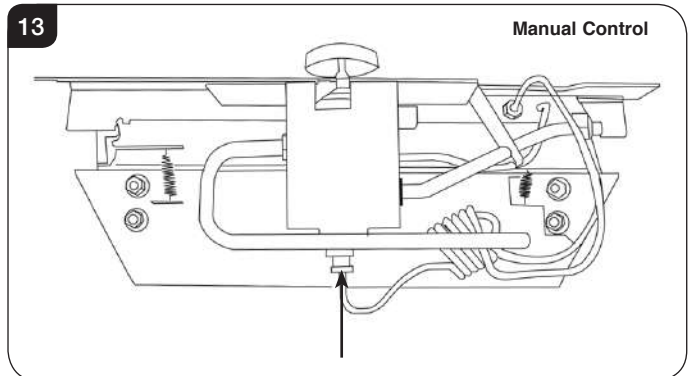

Servicing Instructions - Replacing Parts

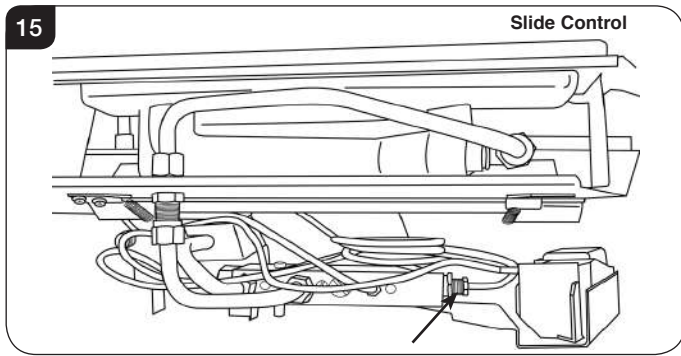

- 3.12 Undo the thermocouple nut in the pilot unit by half a turn. This will release the thermocouple.

LOGIC HE STONE

- 3.13 Remove the sealing plate, see Diagram 16, by removing the pozi head screw.
NOTE: The sealing plate needs to be re-sealed after the new thermocouple is fitted.

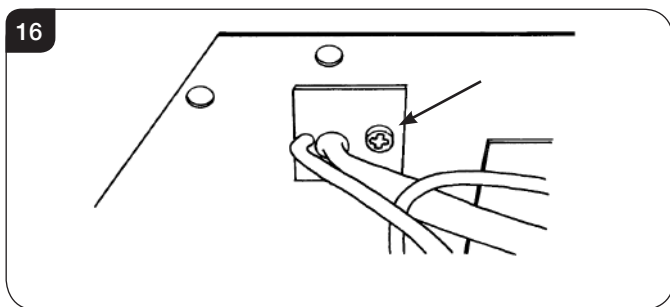

WHEN REPLACING WITH A NEW THERMOCOUPLE TAKE CARE TO BEND THE NEW COMPONENT TO THE EXACT SHAPE OF THE ORIGINAL ONE.

- 3.14 Replace in reverse order.
3.15 When replacing the thermocouple into the pilot unit ensure the component is pushed fully into the hole. There is a stop on the thermocouple to set the height.
3.16 Lock the retaining nut just enough to grip the thermocouple.

4. Piezo Manual & Remote only

Note: For the Manual Control Valve the Ignition lead and Piezo are part of one complete unit and must be replaced at the same time, see Section 6.

Remote Control:

- 4.1 The Piezo assembly used on this appliance is not serviceable and is unlikely to fail. If a new piezo is required it will be necessary to change the gas valve, refer to Section 5.

5. Gas Valve

Manual Control & Remote Control

- 5.1 To remove the gas valve first remove the thermocouple, see Diagram 17 or 18, Arrow A.

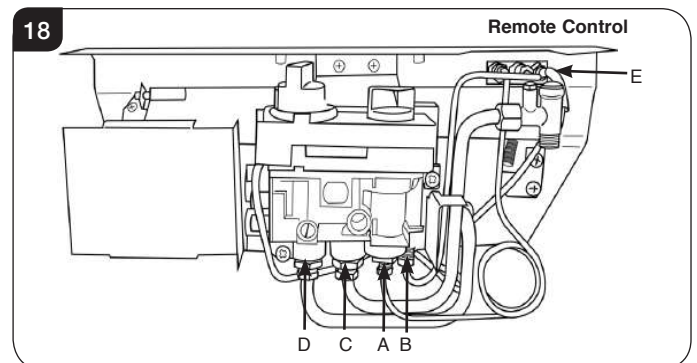
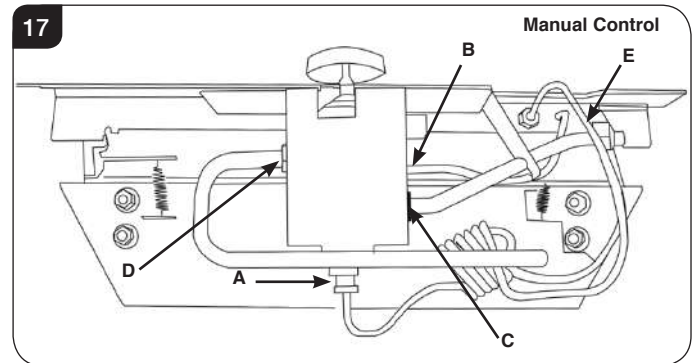

- 5.2 Undo the pilot pipe from the gas valve, see Diagram 17 or 18, Arrow B.
5.3 Undo the inlet pipe from the gas valve, see Diagram 17 or 18, Arrow C.
5.4 Undo the main injector feed pipe from the gas valve, see Diagram 17 or 18, Arrow D.
5.5 Disconnect the ignition lead from the pilot unit, see Diagram 17 or 18, Arrow E. (For Logic HE Stone, the sealing plate needs to be removed, see Diagram 16).

Manual model only:

- 5.6 Pull off the gas valve control knob and remove the locking nut using a 17mm spanner.

Manual and Remote:

- 5.7 The gas valve can now be removed from the burner unit.
5.8 To replace the gas valve reverse the above procedure.

Make sure the sealing plate on Logic HE Stone models is re-sealed.

- 5.9 Check for gas leaks.

Servicing Instructions - Replacing Parts

Slide Control

5.10 To remove the gas valve first remove the thermocouple, see Diagram 19, Arrow A.

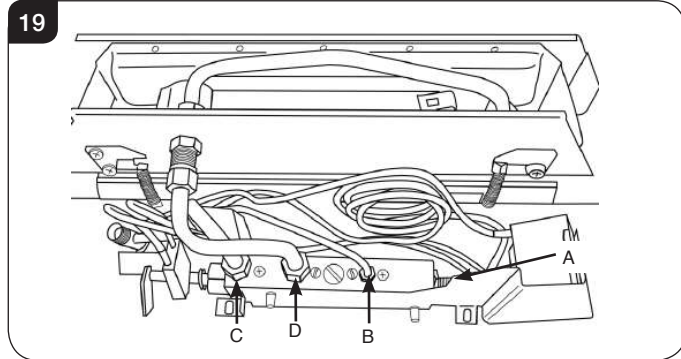

5.11 Undo the pilot pipe from the gas valve, see Diagram 19, Arrow B.

5.12 Undo the inlet pipe from the gas valve, see Diagram 19, Arrow C.

5.13 Undo the main injector feed pipe from the gas valve, see Diagram 19, Arrow D.

5.14 Disconnect the 2 leads from the micro-switch, see Diagram 20.

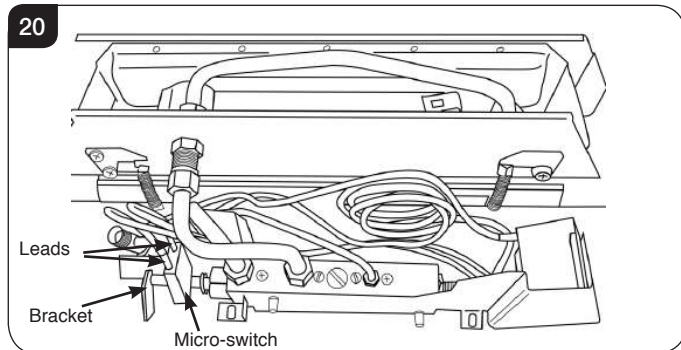

5.15 Undo the screw from the end of the spindle and remove the bracket, see Diagram 21. Ensure the bracket is replaced during reassembly.

5.16 Undo the 2 screws securing the bracket to the bottom of the burner unit, see Diagram 21.

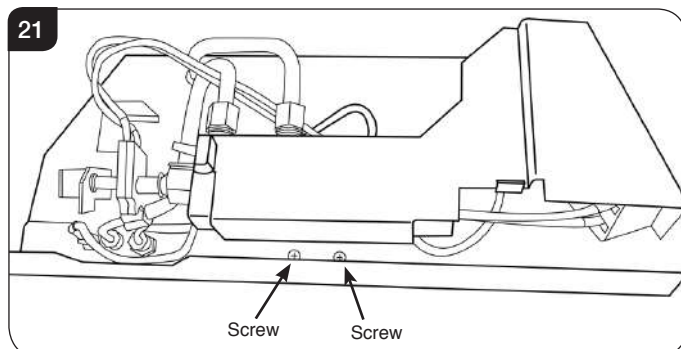

5.17 Undo 2 screws securing the gas valve to the bracket, see Diagram 22.

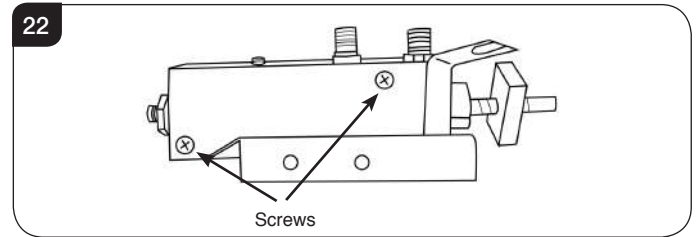

5.18 Replace in reverse order.

5.19 Check for gas leaks.

6. Ignition Lead

6.1 The different control versions of this appliance have different servicing requirements for the Ignition Lead. Follow the relevant section for each product.

Manual Control

6.2 The Ignition lead and Piezo on this appliance are part of one complete unit and must be replaced at the same time.

To replace the unit remove the control knob on the front of the valve cover and undo the nut securing the valve, see Diagram 23.

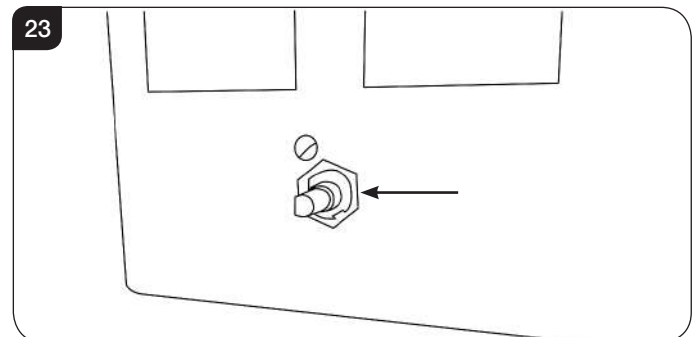

6.3 Disconnect all other valve connections on the rear of the valve.

6.4 The valve will now come off.

6.5 Remove the clip from around the front of the valve, see Diagram 24.

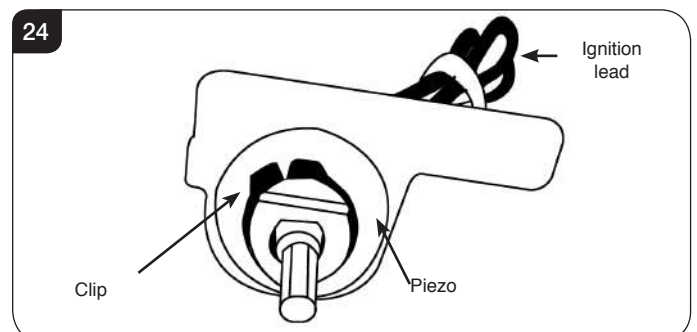

Servicing Instructions - Replacing Parts

- 6.6 Rotate the piezo anti-clockwise until a tab appears in the slot at the front, see Diagram 25.

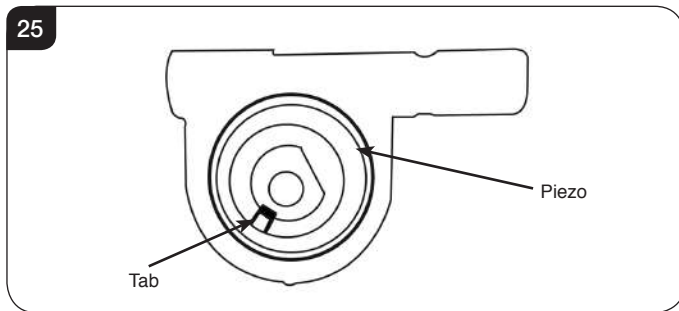

- 6.7 Withdraw the Piezo unit forward from the valve.
6.8 Replace with a new unit and re-assemble the valve into the burner unit.
6.9 Check the operation of the Piezo ignitor making sure that both ignition 'clicks' are functioning.
6.10 Reassemble the appliance.

Remote Control

- 6.11 Undo the single screw that secures the left hand side of the control cover, see Diagram 26.

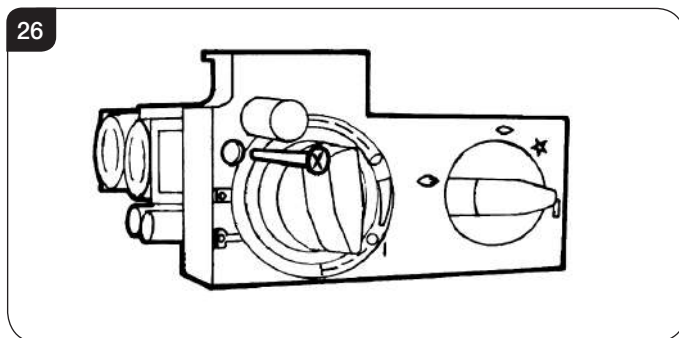

- 6.12 To release the right hand side of the control cover insert the narrow blade screwdriver into the slot shown in Diagram 27, lever it gently and pull from the right hand side at the same time. The cover will now come off, there is a small cylindrical metal spacer inside the cover, this must be kept and replaced on the fixing screw during re-assembly.

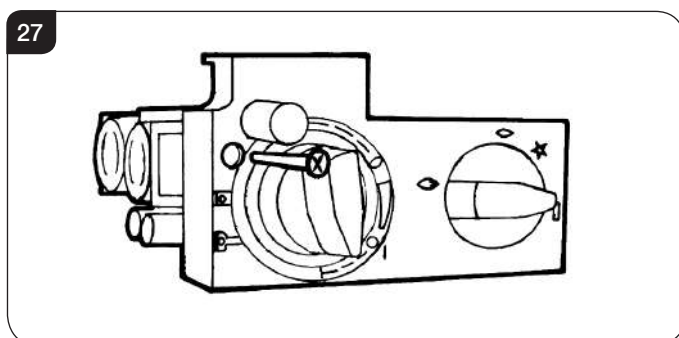

- 6.13 Disconnect the ignition lead from the gas valve and the pilot, see Diagram 28.

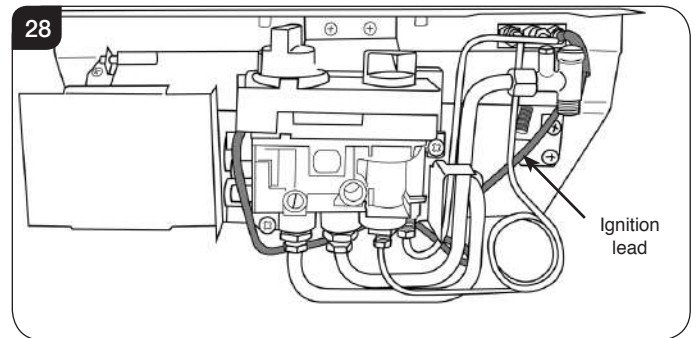

- 6.14 Replace with a new ignition lead following the same route as the old one. Replace the valve cover and the pilot assembly.
6.15 Refit the burner.
6.16 Check the operation of the new ignition lead.
6.17 Reassemble the appliance.

Slide Control

- 6.18 Disconnect the ignition lead from the ignition unit and the pilot unit, see Diagram 29.

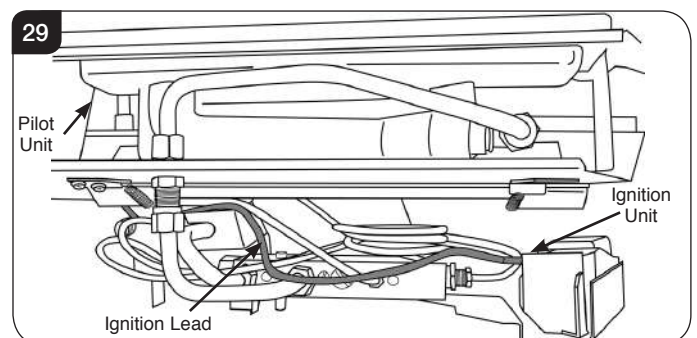

- 6.19 Replace with a new ignition lead following the same route as the old one.
6.20 Refit the burner.
6.21 Check the operation of the new ignition lead.
6.22 Reassemble the appliance.

Servicing Instructions - Replacing Parts

7. Main Injector

- 7.1 Undo the injector compression nut and bulkhead nut, see Diagram 30, 31 or 32, arrows D and E, pull the pipe clear of the injector body.

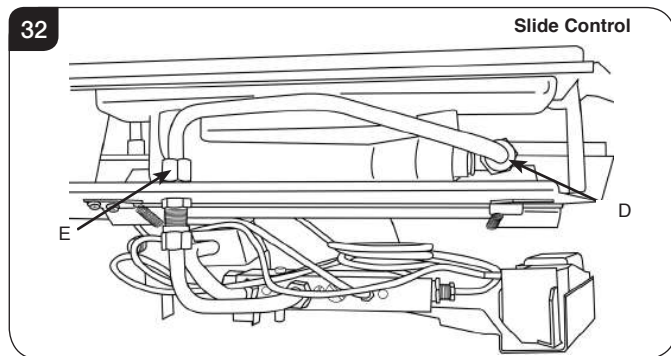
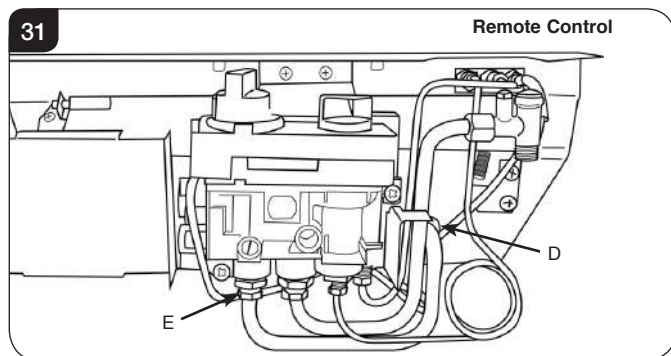
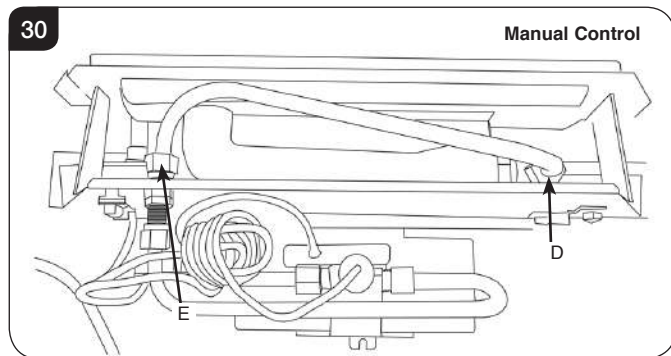

- 7.2 Rotate the injector until it is fully removed.
- 7.3 Replace with the correct replacement injector. When ordering, always state the model, gas type and serial number.
- 7.4 Reassemble and turn the gas supply on, check for any leaks.

8. Mag Unit

- 8.1 Undo the thermocouple nut, see Diagram 33, 34 or 35, Arrow B.

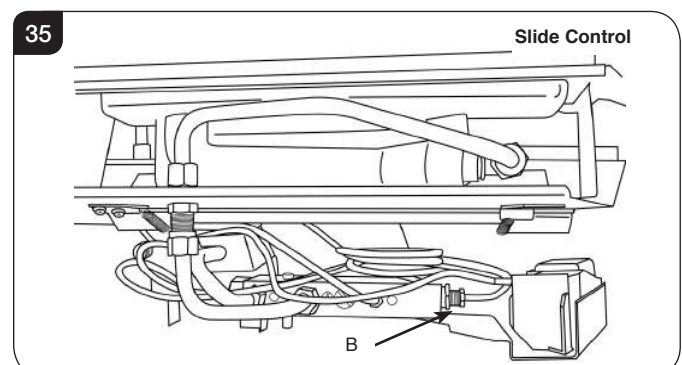
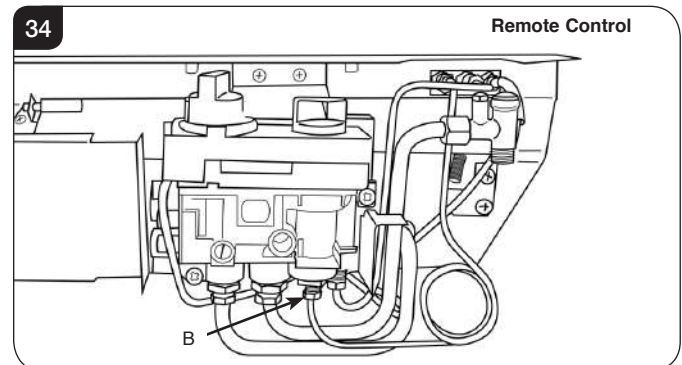
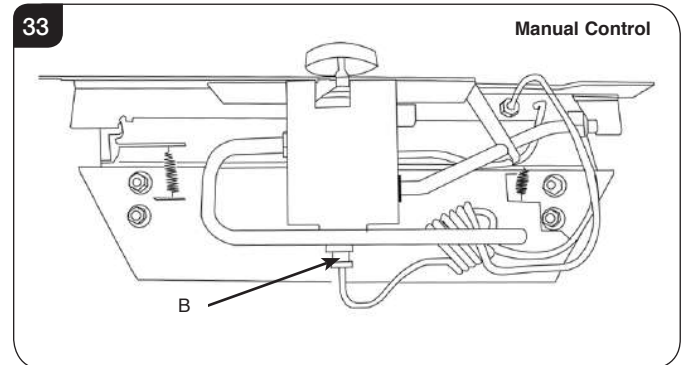

- 8.2 Undo the mag unit retaining nut at the back of the control valve behind the thermocouple nut.
- 8.3 After removing the retaining nut, the mag unit can be tapped out and a replacement fitted.
- 8.4 Replace the mag unit retaining nut and tighten.
Note - this is a gas-tight seal.
- 8.5 Replace the thermocouple and check for gas leaks.
- 8.6 After reassembly, carry out the flame failure functional check as detailed in the Fault Finding chart, especially the time it takes for the mag unit to close.

Servicing Instructions - Replacing Parts

9. Ignition Unit (Slide Control Model only)

- 9.1 Remove the battery, see Section 2.
- 9.2 Remove the 2 leads and the pilot ignition lead from the ignition unit, see Diagram 36.

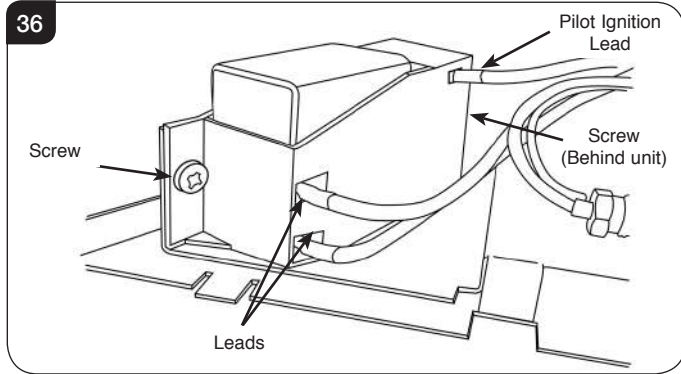

- 9.3 Undo the 2 screws securing the unit in place, see Diagram 33.
- 9.4 Replace in reverse order.

10. Changing between Gas Types

The following parts must be changed when converting an appliance from one gas type to another:

Manual Control:

	BURNER ASSEMBLY		DATABADGE	
	NG	LPG	NG	LPG
LOGIC HE - COAL	GZ8187	GZ8335	PR1053	PR1059
LOGIC HE - STONE	GZ8152	GZ8333	PR1060	PR1061

Remote Control:

	BURNER ASSEMBLY		DATABADGE	
	NG	LPG	NG	LPG
LOGIC HE - COAL	GZ10733	GZ11165	PR1878	
LOGIC HE - STONE	GZ11168	GZ11169		

Slide Control:

	BURNER ASSEMBLY		DATABADGE	
	NG	LPG	NG	LPG
LOGIC HE - COAL	GZ9476	GZ11113	PR1591	
LOGIC HE - STONE	GZ11116	GZ11124		

Note: The control valve will be set for the particular appliance and gas type. In all instances, when ordering new parts, be sure to quote the appliance type and serial number.

Use only genuine Gazco replacement parts. Non-standard components will invalidate the guarantee and may be dangerous.

Servicing Instructions - Replacing Parts

11. Spares List - Manual & Remote Control - Coal

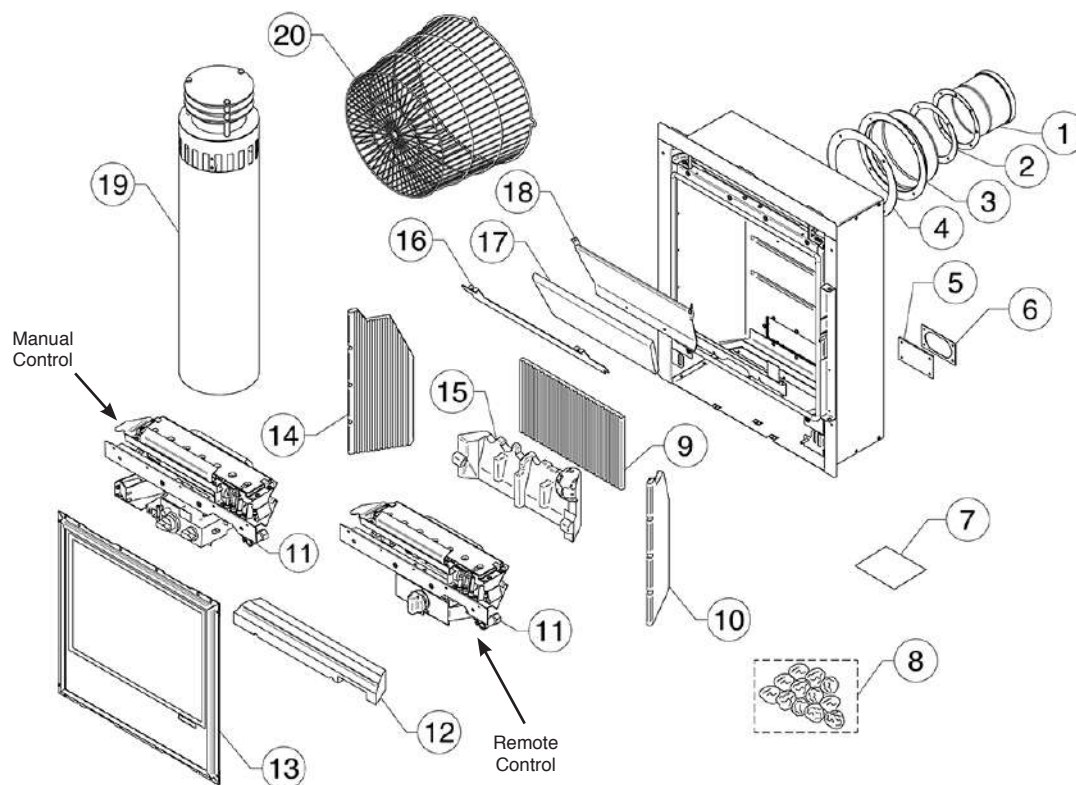

MANUAL				
No.	Component	Part Code		Quantity
		Natural Gas	LPG	
1	Inner Spigot	MEC0275		1
2	Inner Spigot Gasket	CE0210		1
3	Outer Spigot	MEC0269		1
4	Outer Spigot Gasket	CE0211		1
5	Silicon Seal	FA0354		1
6	Gasket Plate	ME3746		1
7	Instruction Manual & Fixing Kit	GZ8948		1
8	Moulded Coal Set	CE0496		1
9	Rear Lining	CE0757		1
10	RH Lining	CE0755		1
11	Engine & Control Assembly	GZ8187	GZ8335	1
12	Front Coal - Black	CE0490		1
13	Glass Frame Assembly	GZ8352		1
14	LH Lining	CE0754		1
15	HE Flame Baffle	CE0758		1
16	Top Inner Baffle	GZ11605		1
17	Top Lining	CE0756		1
18	Top Baffle	GZ8307		1
19	Horizontal Rear Exit Flue Terminal	999-105		1
20	Terminal Guard	999-201		1

REMOTE				
No.	Component	Part Code		Quantity
		Natural Gas	LPG	
1	Inner Spigot	MEC0275		1
2	Inner Spigot Gasket	CE0210		1
3	Outer Spigot	MEC0269		1
4	Outer Spigot Gasket	CE0211		1
5	Silicon Seal	FA0354		1
6	Gasket Plate	ME3746		1
7	Instruction Manual & Fixing Kit	GZ11213		1
8	Moulded Coal Set	CE0496		1
9	Rear Lining	CE0757		1
10	RH Lining	CE0755		1
11	Engine & Control Assembly	GZ10733	GZ11165	1
12	Front Coal - Black	CE0490		1
13	Glass Frame Assembly	GZ8352		1
14	LH Lining	CE0754		1
15	HE Flame Baffle	CE0758		1
16	Top Inner Baffle	GZ11605		1
17	Top Lining	CE0756		1
18	Top Baffle	GZ8307		1
19	Horizontal Rear Exit Flue Terminal	999-105		1
20	Terminal Guard	999-201		1



Due to continual technical improvements please check online or with your Gazco retailer for the most up to date parts lists.

Only use Genuine Gazco spares when servicing your appliance.

All of our essential spare parts and consumable items are available to purchase from our webshop at www.gazcospares.com.

Servicing Instructions - Replacing Parts

11. Spares List - Manual & Remote Control - Stone

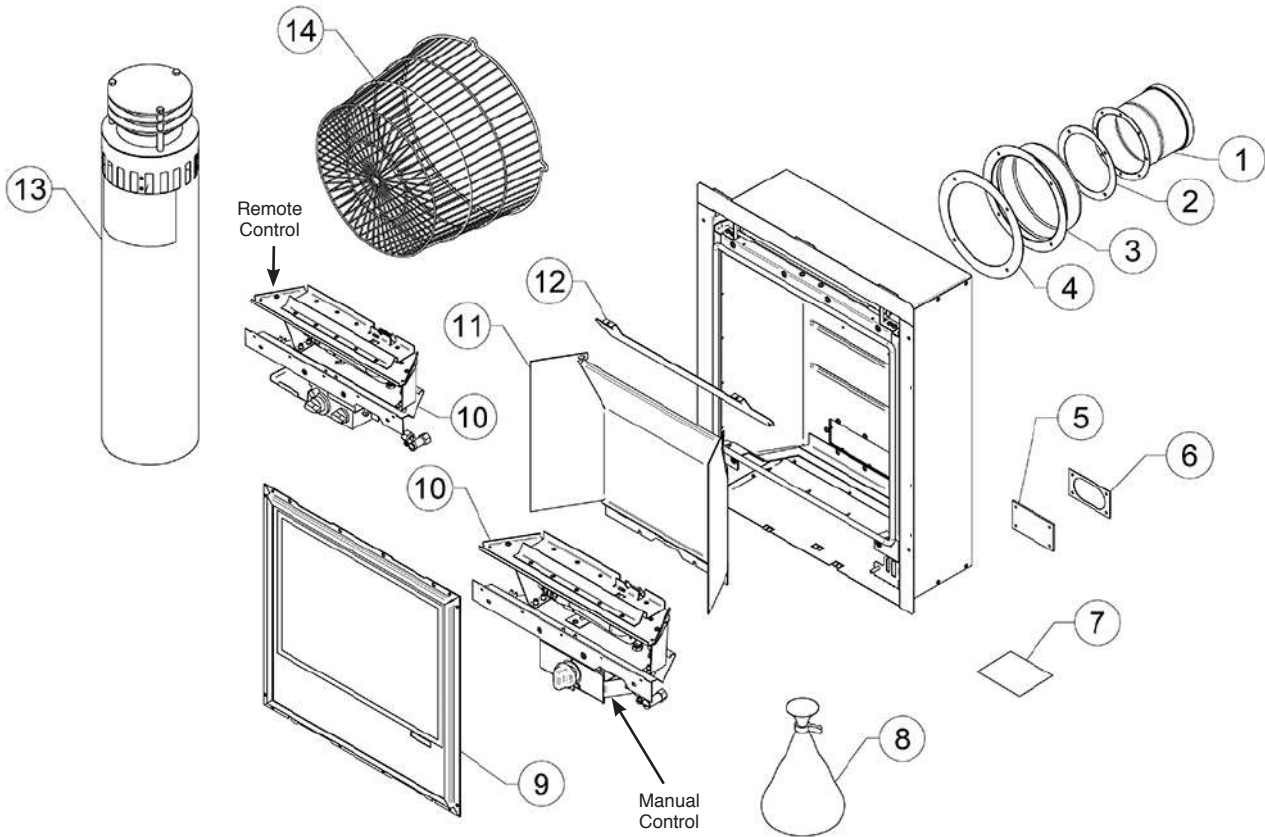

MANUAL				
No.	Component	Part Code		Quantity
		Natural Gas	LPG	
1	Inner Spigot	MEC0275		1
2	Inner Spigot Gasket	CE0210		1
3	Outer Spigot	MEC0269		1
4	Outer Spigot Gasket	CE0211		1
5	Silicon Seal	FA0354		1
6	Gasket Plate	ME3746		1
7	Instruction Manual & Fixing Kit	GZ8948		1
8	White Ceramic Stones	CE1085		1
9	Window Assembly	GZ8352		1
10	Engine & Control Assembly	GZ8152	GZ8333	1
11	Enamel Panel Assembly	GZ8303		1
12	Top Baffle	GZ11605		1
13	Horizontal Rear Exit Flue Terminal	999-105		1
14	Terminal Guard	999-201		1

REMOTE				
No.	Component	Part Code		Quantity
		Natural Gas	LPG	
1	Inner Spigot	MEC0275		1
2	Inner Spigot Gasket	CE0210		1
3	Outer Spigot	MEC0269		1
4	Outer Spigot Gasket	CE0211		1
5	Silicon Seal	FA0354		1
6	Gasket Plate	ME3746		1
7	Instruction Manual & Fixing Kit	GZ11213		1
8	White Ceramic Stones	CE1085		1
9	Window Assembly	GZ8352		1
10	Engine & Control Assembly	GZ11168	GZ11169	1
11	Enamel Panel Assembly	GZ8303		1
12	Top Baffle	GZ11605		1
13	Horizontal Rear Exit Flue Terminal	999-105		1
14	Terminal Guard	999-201		1



Due to continual technical improvements please check online or with your Gazco retailer for the most up to date parts lists.

Only use Genuine Gazco spares when servicing your appliance.

All of our essential spare parts and consumable items are available to purchase from our webshop at www.gazcospares.com.

Servicing Instructions - Replacing Parts

11. Spares List - Manual Control - Coal - Main Burner Assembly

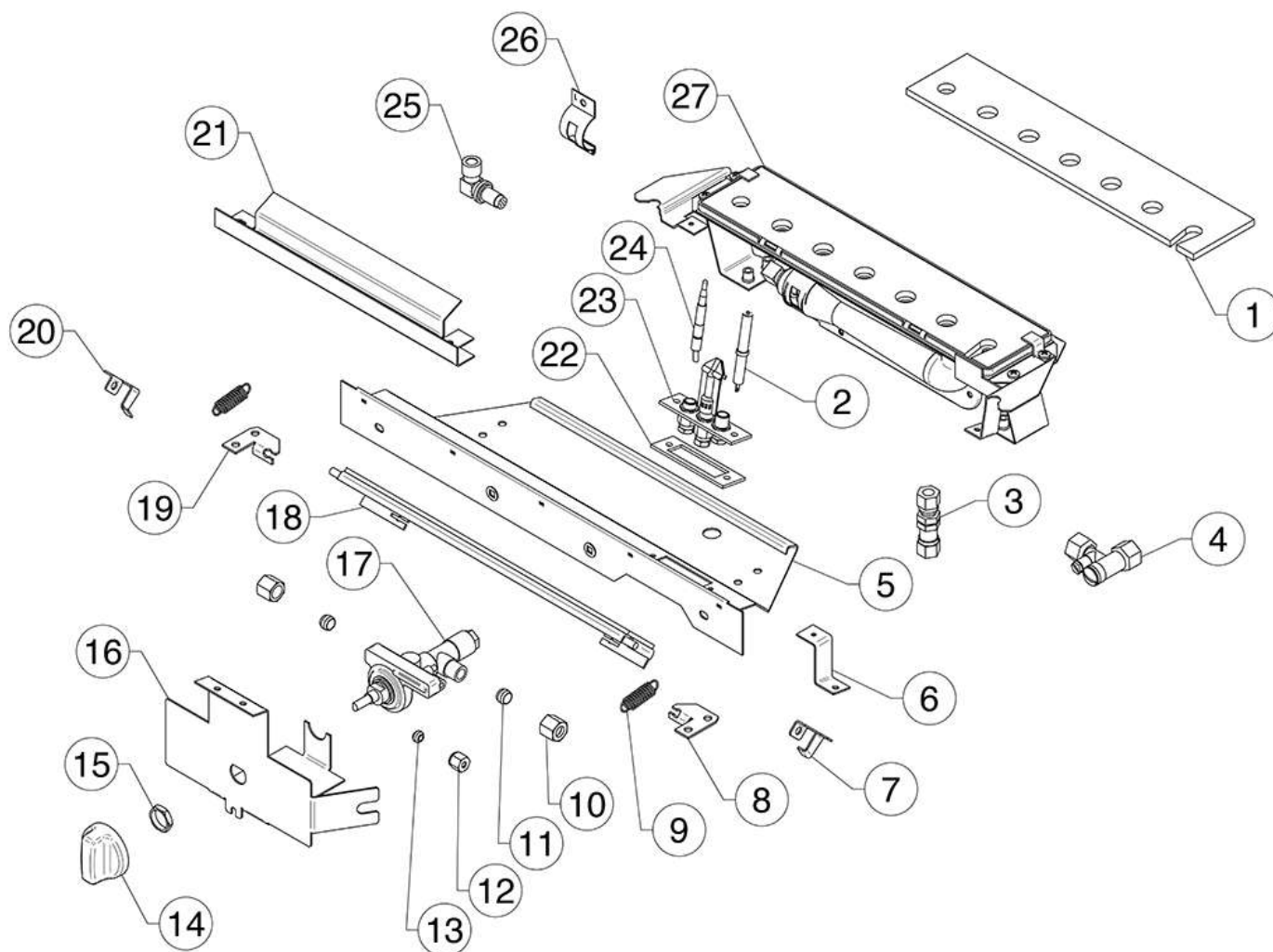

No.	Component	Part Code		Quantity
		Natural Gas	LPG	
1	Burner Gasket	CE0836	CE0837	1
2	Electrode	PI0075		1
3	8mm Bulkhead Fitting	FA0271		1
4	Restrictor Elbow	GC0095		1
5	Burner Tray	GZ8340		1
6	Front Channel Bracket	GZ8982		1
7	Retaining Bracket RH	GZ8382		1
8	Spring Bracket RH	GZ8384		1
9	Explosion Relief Spring	FA0269		2
10	8mm Nut	FA0122		2
11	Olive	FA0011		2
12	4mm Nut	FA0123		1
13	Olive	FA0071		1
14	Control Knob	GZ0058		1

No.	Component	Part Code		Quantity
		Natural Gas	LPG	
15	Lock Nut	FA0121		1
16	Valve Bracket	GZ8158		1
17	Valve	GC0156	GC0158	1
18	Explosion Relief Plate	GZ6845		1
19	Spring Bracket LH	GZ8383		1
20	Retaining Bracket LH	GZ8381		1
21	Burner Tray - Front Panel	GZ8348		1
22	Pilot Gasket	CE0477		1
23	Pilot	PI0069	PI0070	1
24	Thermocouple	PI0077		1
25	Injector	IN0001	IN0056	1
26	Aeration Plate	GZ3966	N/A	1
27	Burner Assembly	GZ8356	GZ8357	1



Due to continual technical improvements please check online or with your Gazco retailer for the most up to date parts lists.

Only use Genuine Gazco spares when servicing your appliance.

All of our essential spare parts and consumable items are available to purchase from our webshop at www.gazcospares.com.

Servicing Instructions - Replacing Parts

11. Spares List - Manual Control - Stone - Main Burner Assembly

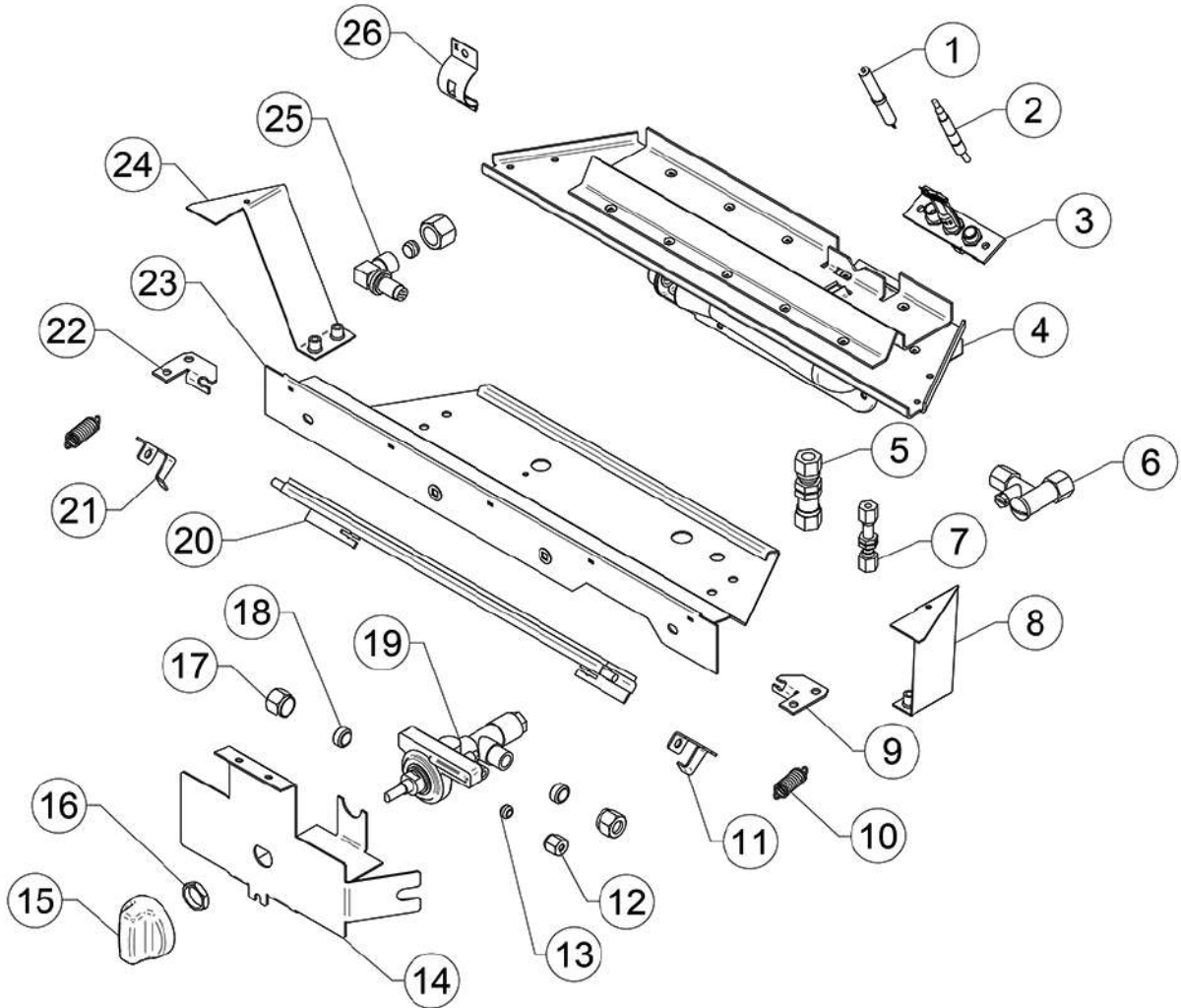

No.	Component	Part Code		Quantity
		Natural Gas	LPG	
1	Electrode	PI0075		1
2	Thermocouple	PI0074	PI0077	1
3	Pilot	PI0069	PI0070	1
4	Burner Assembly	GZ8153	GZ8334	1
5	8mm Bulkhead Fitting	FA0271		1
6	Restrictor Elbow	GC0095		1
7	4mm Bulkhead Fitting	FA0270		1
8	RH Burner Support	GZ8377		1
9	Spring Bracket RH	GZ8384		1
10	Explosion Relief Spring	FA0269		2
11	Retaining Bracket RH	GZ8382		1
12	4mm Nut	FA0123		1
13	Olive	FA0071		1

No.	Component	Part Code		Quantity
		Natural Gas	LPG	
14	Valve Bracket	GZ8158		1
15	Control Knob	GC0058		1
16	Locknut	FA0121		1
17	8mm Nut	FA0122		2
18	Olive	FA0011		2
19	Valve	GC0156	GC0158	1
20	Explosion Relief Plate	GZ6845		1
21	Retaining Bracket LH	GZ8381		1
22	Spring Bracket LH	GZ8383		1
23	Burner Tray Assembly	GZ8156		1
24	LH Burner Support	GZ8376		1
25	Injector	IN0051	IN0049	1
26	Aeration Plate	GZ3869	GZ3867	1



Due to continual technical improvements please check online or with your Gazco retailer for the most up to date parts lists.

Only use Genuine Gazco spares when servicing your appliance.

All of our essential spare parts and consumable items are available to purchase from our webshop at www.gazcospares.com.

Servicing Instructions - Replacing Parts

11. Spares List - Remote Control - Coal - Main Burner Assembly

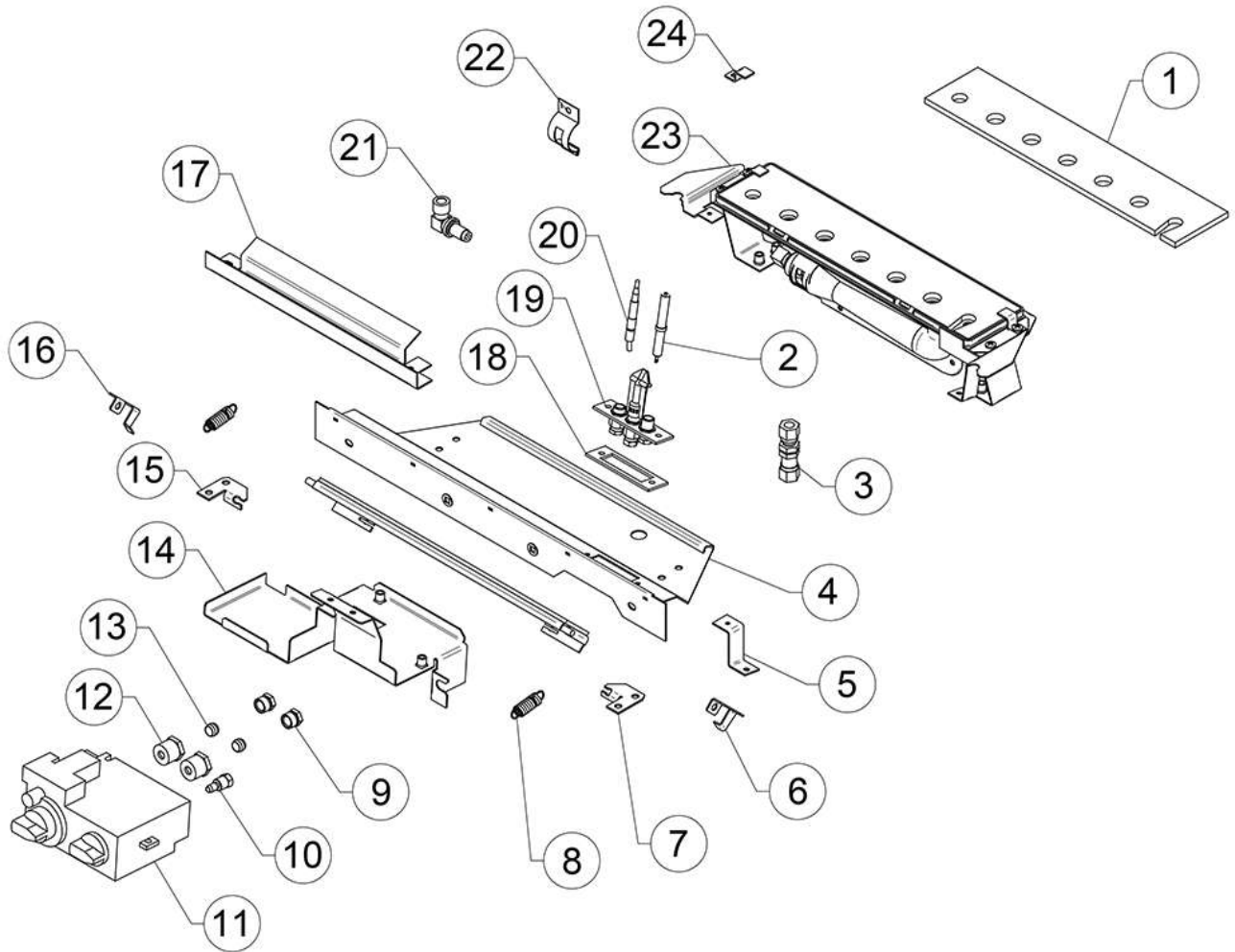

No.	Component	Part Code		Quantity	No.	Component	Part Code		Quantity
		Natural Gas	LPG				Natural Gas	LPG	
1	Burner Gasket	CE0836	CE0837	1	13	Olive	FA0011	2	
2	Electrode	PI0075		1	14	Main Control Bracket	GZ10734		1
3	8mm Bulkhead Fitting	FA0271		1	15	Spring Bracket LH	GZ8383		1
4	Burner Tray	GZ8340		1	16	Retaining Bracket LH	GZ8381		1
5	Front Channel Bracket	GZ8982		1	17	Front Burner Tray	GZ8348		1
6	Retaining Bracket RH	GZ8382		1	18	Pilot Gasket	CE0477		1
7	Spring Bracket RH	GZ8384		1	19	Pilot	PI0069	PI0070	1
8	Explosion Relief Spring	FA0269		2	20	Thermocouple	PI0077		1
9	8mm Internal Tube Nut	FA0295		2	21	Injector	IN0001	IN0056	1
10	Shear Nut & Olive	GC0024		1	22	Aeration Plate	GZ3966	N/A	1
11	Valve	GC0088		1	23	Burner Assembly	GZ8423	GZ8357	1
12	8mm Internal Tube Nut	FA0295		2	24	Burner Gasket Bracket	GZ8090		1



Due to continual technical improvements please check online or with your Gazco retailer for the most up to date parts lists.

Only use Genuine Gazco spares when servicing your appliance.

All of our essential spare parts and consumable items are available to purchase from our webshop at www.gazcospares.com.

Servicing Instructions - Replacing Parts

11. Spares List - Remote Control - Stone - Main Burner Assembly

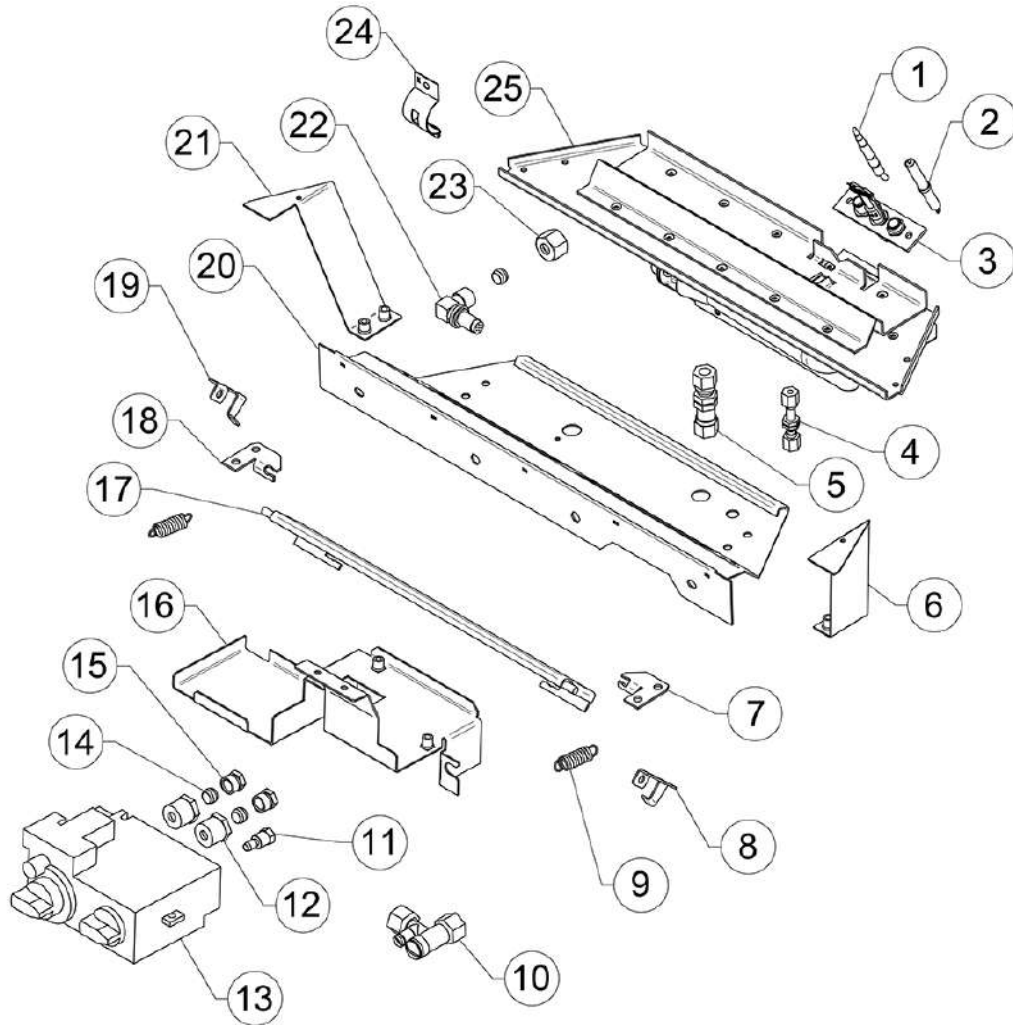

No.	Component	Part Code		Quantity
		Natural Gas	LPG	
1	Thermocouple	PI0077		1
2	Electrode	PI0075		1
3	Pilot	PI0069	PI0070	1
4	4mm Bulkhead Fitting	FA0270		1
5	8mm Bulkhead Fitting	FA0271		1
6	Burner Tray Support RH	GZ8377		1
7	Spring Bracket RH	EL8384		1
8	Retaining Bracket RH	GZ8382		1
9	Explosion Relief Spring	FA0269		2
10	Restrictor Elbow	GC0095		1
11	Shear Nut & Olive	GC0024		1
12	3/8 BSP Brass Adapter	FA0294		2

No.	Component	Part Code		Quantity
		Natural Gas	LPG	
13	Valve	GC0088		1
14	Olive	FA0011		3
15	8mm Tube Inlet Nut	FA0295		2
16	Main Control Bracket	GZ10734		1
17	Explosion Relief Flap Assembly	GZ6845		1
18	Spring Bracket LH	GZ8383		1
19	Retaining Bracket LH	GZ8381		1
20	Burner Tray Assembly	GZ8156		1
21	Burner Tray Support LH	GZ8376		1
22	Injector	IN0051	IN0049	1
23	8mm Tube Nut 11mm Long	FA0029		1
24	Aeration Cover	GZ3869	GZ3867	1
25	Burner Assembly	GZ8153	GZ8334	1



Due to continual technical improvements please check online or with your Gazco retailer for the most up to date parts lists.

Only use Genuine Gazco spares when servicing your appliance.
All of our essential spare parts and consumable items are available to purchase from our webshop at www.gazcospares.com.

Servicing Instructions - Replacing Parts

11. Spares List - Remote Control - Coal & Stone Control Assembly

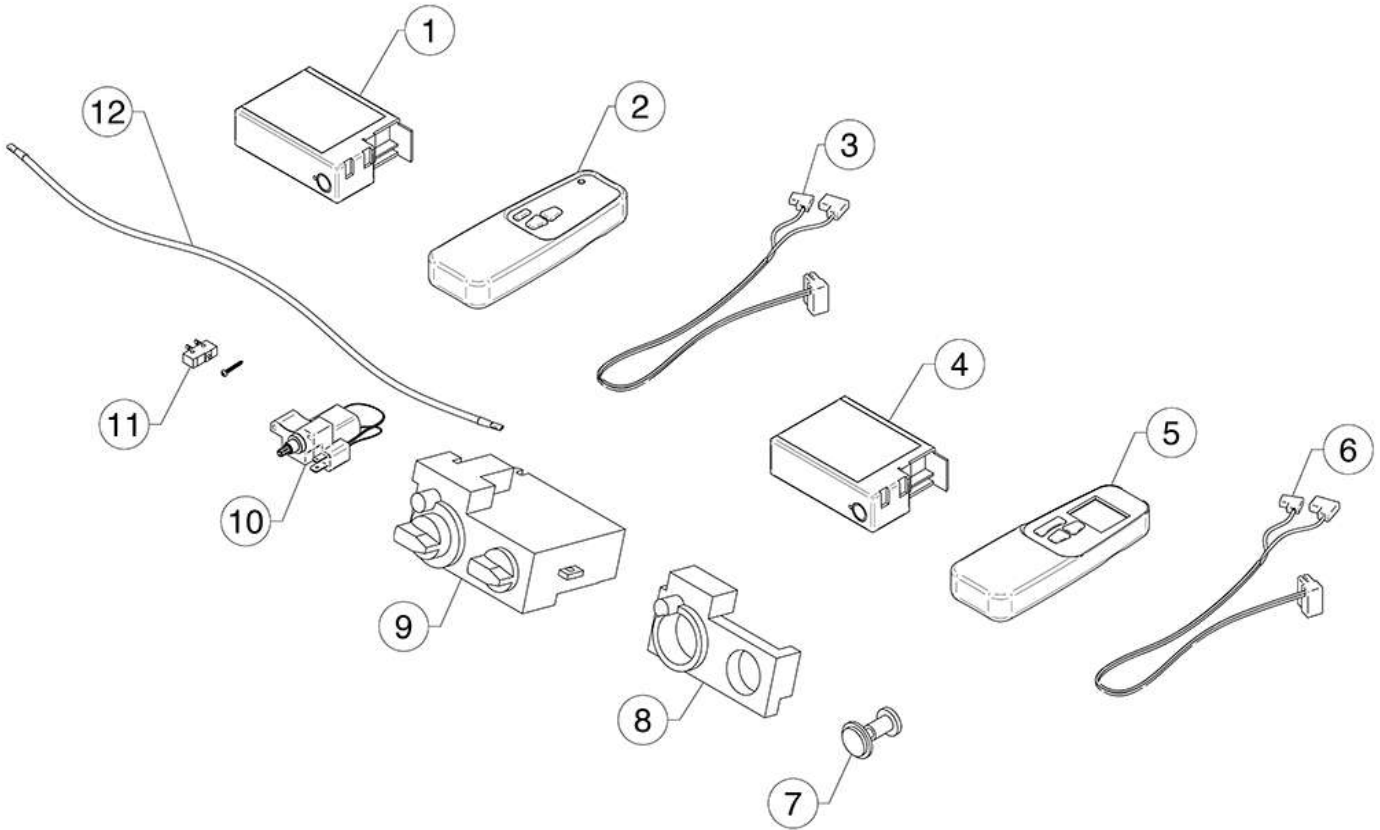

No.	Component	Part Code		
		Natural Gas	LPG	Quantity
1	Standard Receiver	EL0235		1
2	Standard Handset	EL0239		1
3	Standard Receiver Cable	EL0237		1
4	Thermostatic Receiver	EL0236		1
5	Thermostatic Handset	EL0240		1
6	Thermostatic Receiver Cable	EL0238		1
7	Mag Unit	GC0166		1
8	Control Valve Cover	GC0087		1
9	Control Valve	GC0088K		1
10	Geared Motor	EL0234		1
11	Micro Switch and Screw	EL0241		1
12	Ignition Lead	GC0090		1



Due to continual technical improvements please check online or with your Gazco retailer for the most up to date parts lists.

Only use Genuine Gazco spares when servicing your appliance.

All of our essential spare parts and consumable items are available to purchase from our webshop at www.gazcospares.com.

Servicing Instructions - Replacing Parts

11. Spares List - Slide Control - Coal

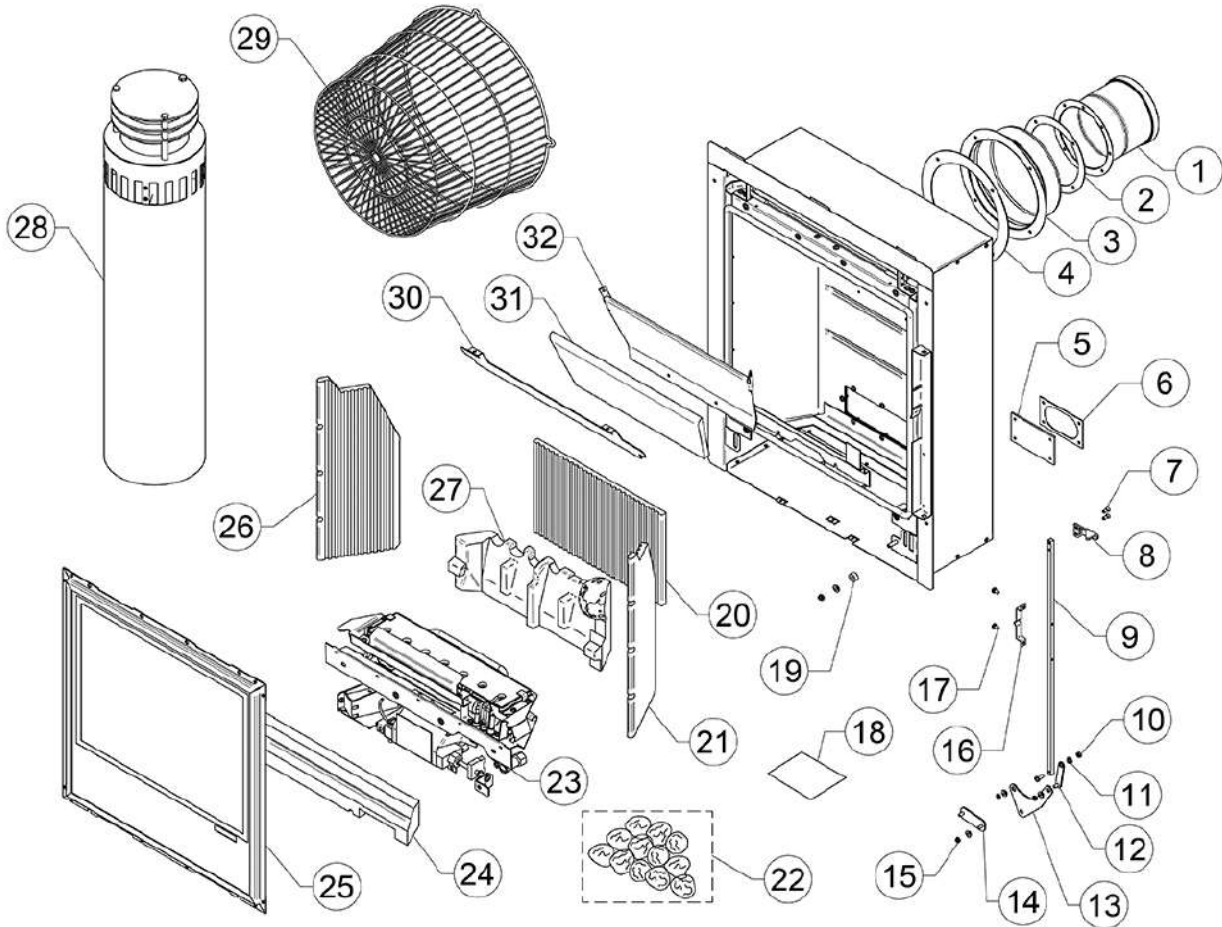

No.	Component	Part Code		Quantity
		Natural Gas	LPG	
1	Inner Spigot	MEC0275		1
2	Inner Spigot Gasket	CE0210		1
3	Outer Spigot	MEC0269		1
4	Outer Spigot Gasket	CE0211		1
5	Silicon Seal	FA0354		1
6	Gasket Plate	ME3746		1
7	M4 x 10 Screw	FA0330		2
8	Handle	GZ11002		1
9	Pushrod	GZ11009		1
10	Hex Nut M4	FA0202		3
11	Circular Clearance Spacer - M4	FA0685		4
12	Link Plate - Small	GZ10052		1
13	Crank Lever	ME11008		1
14	Bottom Link Plate	GZ11006		1
15	M4 Nyloc Nut	C94323		4
16	Spring Clip	GZ11061		1

No.	Component	Part Code		Quantity
		Natural Gas	LPG	
17	M4 x 6 Pozi Drive Screw	FA0694		2
18	Instruction Manual & Fixing Kit	GZ10077		1
19	Large Steel Spacer	FA0691		1
20	Rear Lining	CE0757		1
21	RH Lining	CE0755		1
22	Moulded Coal Set	CE0496		1
23	Engine & Control Assembly	GZ9476	GZ11113	1
24	Front Coal - Black	CE0490		1
25	Glass Frame Assembly	GZ8352		1
26	LH Lining	CE0754		1
27	HE Flame Baffle	CE0758		1
28	Horizontal Rear Exit Flue Terminal	999-105		1
29	Terminal Guard	999-201		1
30	Top Inner Baffle	GZ11605		1
31	Top Lining	CE0756		1
32	Top Baffle	GZ8307		1



Due to continual technical improvements please check online or with your Gazco retailer for the most up to date parts lists.

Only use Genuine Gazco spares when servicing your appliance.

All of our essential spare parts and consumable items are available to purchase from our webshop at www.gazcospares.com.

Servicing Instructions - Replacing Parts

11. Spares List - Slide Control - Stone

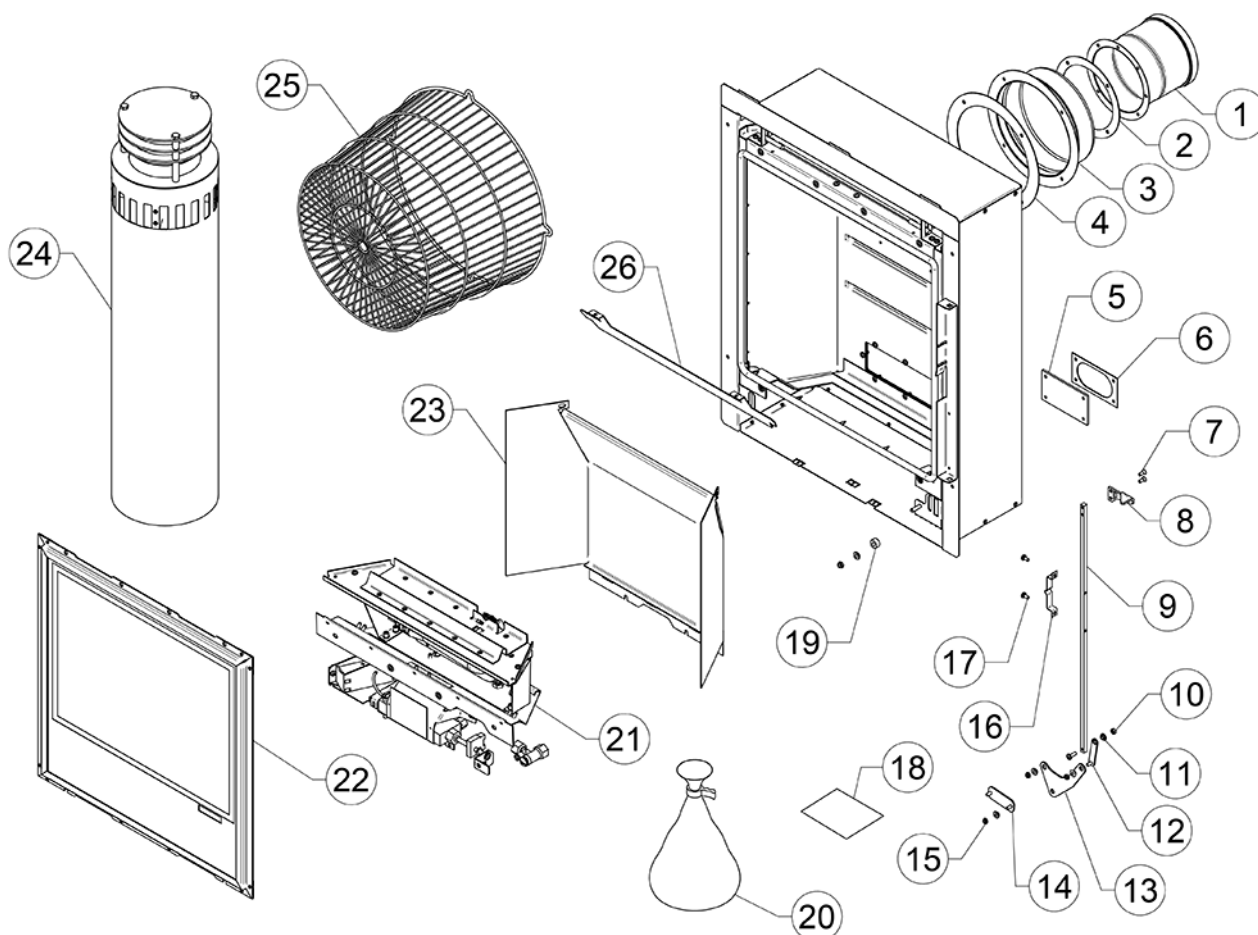

No.	Component	Part Code		Quantity
		Natural Gas	LPG	
1	Inner Spigot	MEC0275		1
2	Inner Spigot Gasket	CE0210		1
3	Outer Spigot	MEC0269		1
4	Outer Spigot Gasket	CE0211		1
5	Silicon Seal	FA0354		1
6	Gasket Plate	ME3746		1
7	M4 x 10 Screw	FA0330		2
8	Handle	GZ11002		1
9	Pushrod	GZ11009		1
10	Hex Nut M4	FA0202		3
11	Circular Clearance Spacer - M4	FA0685		4
12	Link Plate - Small	GZ10052		1
13	Crank Lever	ME11008		1

No.	Component	Part Code		Quantity
		Natural Gas	LPG	
14	Bottom Link Plate	GZ11006		1
15	M4 Nyloc Nut	C94323		4
16	Spring Clip	GZ11061		1
17	M4 x 6 Pozi Drive Screw	FA0694		2
18	Instruction Manual & Fixing Kit	GZ10077		1
19	Large Steel Spacer	FA0691		1
20	Ceramic Stones	CE1085		1
21	Engine & Control Assembly	GZ11116	GZ11124	1
22	Glass Frame Assembly	GZ8352		1
23	Enamel Panel Assembly	GZ8303		1
24	Horizontal Rear Exit Flue Terminal	999-105		1
25	Terminal Guard	999-201		1
26	Top Inner Baffle	GZ11605		1



Due to continual technical improvements please check online or with your Gazco retailer for the most up to date parts lists.

Only use Genuine Gazco spares when servicing your appliance.

All of our essential spare parts and consumable items are available to purchase from our webshop at www.gazcospares.com.

Servicing Instructions - Replacing Parts

11. Spares List - Slide Control - Coal - Main Burner Assembly

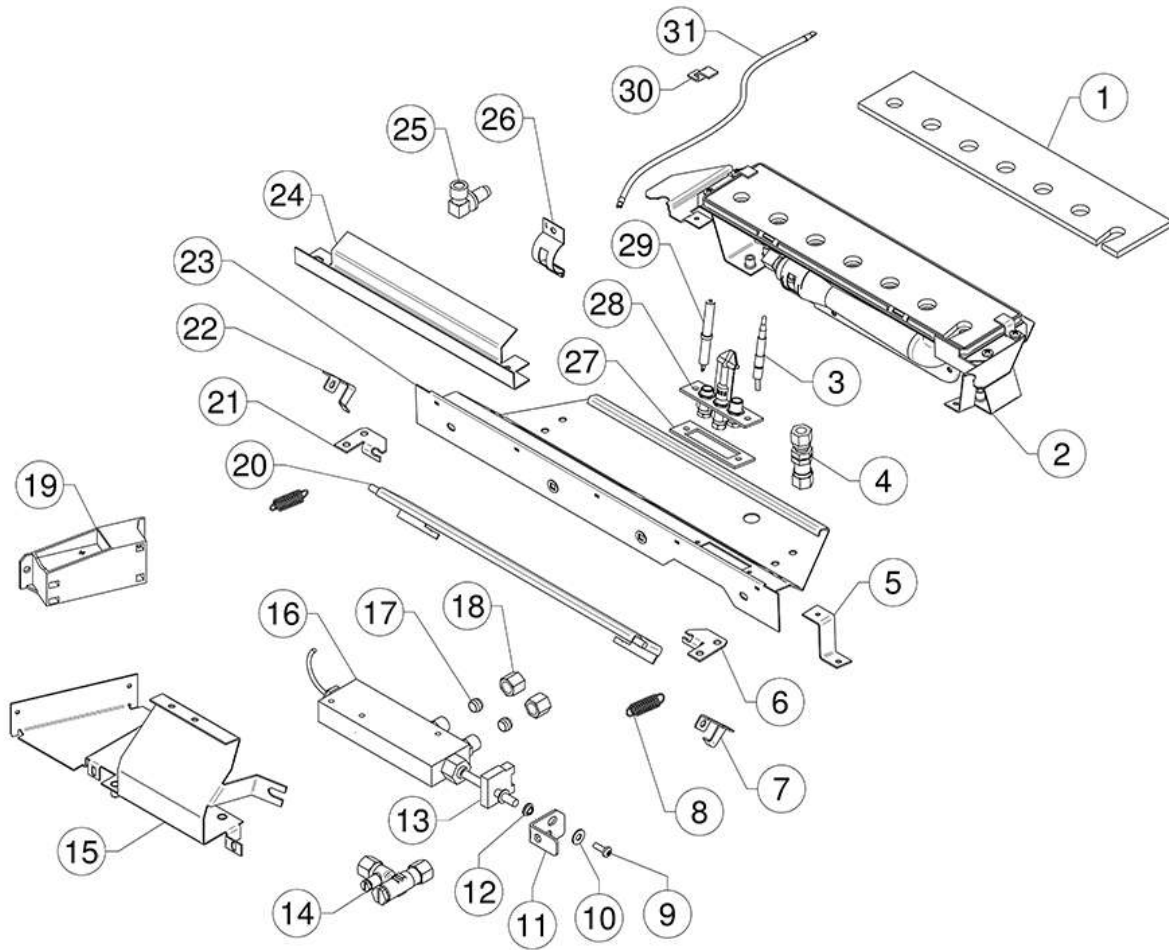

No.	Component	Part Code		Quantity
		Natural Gas	LPG	
1	Burner Gasket	CE0836	CE0837	1
2	Burner Assembly	GZ8356	GZ8357	1
3	Thermocouple	PI0077		1
4	8mm Bulkhead Coupling	FA0271		1
5	Front Channel Bracket	GZ8982		1
6	Spring Bracket RH	GZ8384		1
7	Retaining Bracket RH	GZ8382		1
8	Explosion Relief Spring	FA0269		1
9	M4 x 12mm Pan Screw	D2150-1412		1
10	Washer	FA0705		1
11	Actuator Bracket	GZ11007		1
12	Circular Clearance Spacer	FA0685		1
13	Micro-Switch Fixing Kit	GC0179		1
14	Restrictor Elbow	GC0095		1
15	Main Control Bracket	GZ9469		1
16	Valve	GC0168		1

No.	Component	Part Code		Quantity
		Natural Gas	LPG	
17	Olive	FA0011		2
18	Control Nut 8mm	FA0122		2
19	Ignitor	EL0573		1
20	Explosion Relief Plate	GZ6845		1
21	Spring Bracket LH	GZ8383		1
22	Retaining Bracket LH	GZ8381		1
23	Burner Tray Assembly	GZ8340		1
24	Front Burner Tray	GZ8348		1
25	Injector	IN0001		1
26	Aeration Plate	GZ3966	N/A	1
27	Pilot Gasket	CE0477		1
28	Pilot	PI0069	PI0070	1
29	Electrode	PI0075		1
30	Burner Gasket Bracket	GZ8090		1
31	Ignition Lead	EL0578		3



Due to continual technical improvements please check online or with your Gazco retailer for the most up to date parts lists.

Only use Genuine Gazco spares when servicing your appliance.

All of our essential spare parts and consumable items are available to purchase from our webshop at www.gazcospares.com.

Servicing Instructions - Replacing Parts

11. Spares List - Slide Control - Stone - Main Burner Assembly

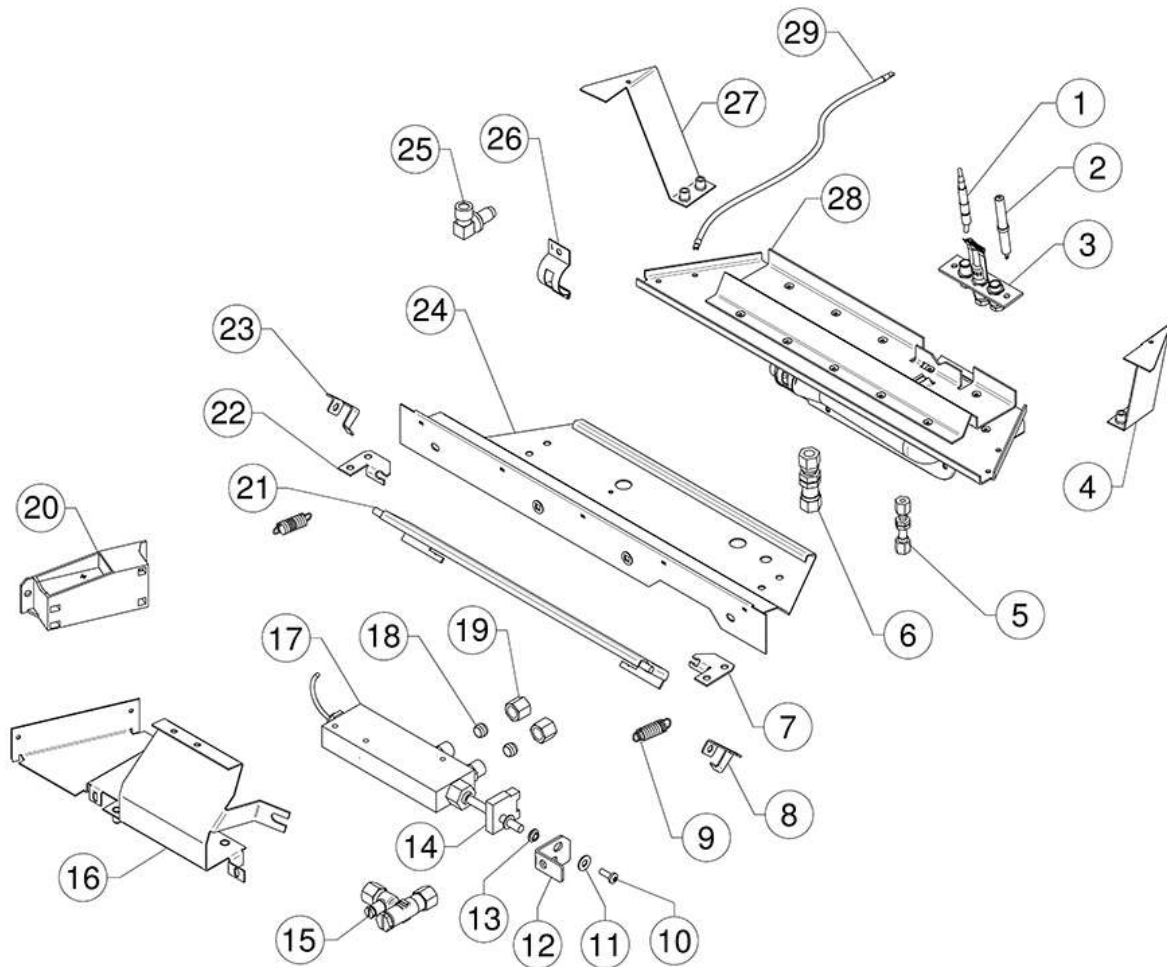

No.	Component	Part Code		Quantity
		Natural Gas	LPG	
1	Thermocouple	PI0077		1
2	Electrode	PI0075		1
3	Pilot	PI0069	PI0070	1
4	RH Burner Tray Support Bracket	GZ8377		
5	4mm Bulkhead Coupling	FA0270		1
6	8mm Bulkhead Coupling	FA0271		1
7	Spring Bracket RH	EL8384		1
8	Retaining Bracket RH	GZ8382		1
9	Explosion Relief Spring	FA0269		1
10	M4 x 12mm Pan Screw	D2150-1412		1
11	Washer	FA0705		1
12	Actuator Bracket	GZ11007		1
13	Circular Clearance Spacer	FA0685		1
14	Micro-Switch Fixing Kit	GC0179		1
15	Restrictor Elbow	GC0095		1

No.	Component	Part Code		Quantity
		Natural Gas	LPG	
16	Main Control Bracket	GZ9469		1
17	Valve	GC0168		2
18	Olive	FA0011		2
19	Control Nut 8mm	FA0122		1
20	Ignitor	EL0573		1
21	Explosion Relief Plate	GZ6845		1
22	Spring Bracket LH	GZ8383		1
23	Retaining Bracket LH	GZ8381		1
24	Burner Tray Assembly	GZ8156		1
25	Injector	IN0051	IN0049	1
26	Aeration Plate	GZ3869	GZ3867	1
27	LH Burner Tray Support Bracket	GZ8376		1
28	Burner Assembly	GZ8153	GZ8334	1
29	Ignitor Lead	EL0578		3



Due to continual technical improvements please check online or with your Gazco retailer for the most up to date parts lists.

Only use Genuine Gazco spares when servicing your appliance.

All of our essential spare parts and consumable items are available to purchase from our webshop at www.gazcospares.com.

Service Records

1ST SERVICE

Date of Service:.....
Next Service Due:.....
Signed:.....
Retailer's Stamp/GasSafe Registration Number

3RD SERVICE

Date of Service:.....
Next Service Due:.....
Signed:.....
Retailer's Stamp/GasSafe Registration Number

5TH SERVICE

Date of Service:.....
Next Service Due:.....
Signed:.....
Retailer's Stamp/Gas Safe Registration Number

7TH SERVICE

Date of Service:.....
Next Service Due:.....
Signed:.....
Retailer's Stamp/GasSafe Registration Number

9TH SERVICE

Date of Service:.....
Next Service Due:.....
Signed:.....
Retailer's Stamp/GasSafe Registration Number

2ND SERVICE

Date of Service:.....
Next Service Due:.....
Signed:.....
Retailer's Stamp/GasSafe Registration Number

4TH SERVICE

Date of Service:.....
Next Service Due:.....
Signed:.....
Retailer's Stamp/GasSafe Registration Number

6TH SERVICE

Date of Service:.....
Next Service Due:.....
Signed:.....
Retailer's Stamp/GasSafe Registration Number

8TH SERVICE

Date of Service:.....
Next Service Due:.....
Signed:.....
Retailer's Stamp/GasSafe Registration Number

10TH SERVICE

Date of Service:.....
Next Service Due:.....
Signed:.....
Retailer's Stamp/GasSafe Registration Number

Information Requirement - Gas Heaters

Information Requirement for Gaseous Fuel Local Space Heater

Model		Logic HE BF Manual Control NG Coal	Logic HE BF Manual Control LPG Coal	Logic HE BF Manual Control NG Stones	Logic HE BF Manual Control LPG Stones
Fuel	Space Heating Emissions (NOx) - mg / kWh _{input} (GCV)	130	130	130	130

Heat Output	Nominal Heat Output - P_{nom}	3.1kW	3.2kW	2.6kW	2.7kW
	Minimum Heat Output (indicative) - P_{min}	1.6kW	1.5kW	1.4kW	1.4kW

Auxiliary Electricity Consumption	At Nominal Heat Output - $e_{l,max}$	N/A	N/A	N/A	N/A
	At Minimum Heat Output - $e_{l,min}$	N/A	N/A	N/A	N/A
	In Standby Mode - $e_{l,sb}$	N/A	N/A	N/A	N/A

Useful Efficiency (NCV)	Useful Efficiency at nominal heat output - $\eta_{th,nom}$	86.0%	86.0%	86.0%	86.0%
	Useful Efficiency at minimum heat output (indicative) - $\eta_{th,min}$	76.0%	76.0%	76.0%	76.0%

Permanent Pilot Flame Power requirement	Permanent Pilot Flame Power requirement (if applicable) - P_{pilot}	0.200kW	0.200kW	0.200kW	0.200kW
---	---	---------	---------	---------	---------

Type of heat output/room temperature control - Manual Control

Two or more manual stages, no room temperature control	Yes	Yes	Yes	Yes
--	-----	-----	-----	-----

Other control options (multiple selections possible)

Room temperature control, with presence detection	No	No	No	No
Room temperature control, with open window detection	No	No	No	No
With distance control option	No	No	No	No
With adaptive start control	No	No	No	No
With working time limitation	No	No	No	No
With black bulb sensor	No	No	No	No

Energy Efficiency Index	73.8%	73.8%	73.2%	73.3%
Energy Efficiency Class	D	D	D	D

Contact:	Gazco Ltd, Osprey Road, Sowton Industrial Estate, Exeter, EX2 7JG
----------	---

Information Requirement - Gas Heaters

Information Requirement for Gaseous Fuel Local Space Heater

Model		Logic HE BF Remote Control NG Coal	Logic HE BF Remote Control LPG Coal	Logic HE BF Remote Control NG Stones	Logic HE BF Remote Control LPG Stones
Fuel	Space Heating Emissions (NOx) - mg / kWh _{input} (GCV)	130	130	130	130

Heat Output	Nominal Heat Output - P_{nom}	3.3kW	3.2kW	2.6kW	2.7kW
	Minimum Heat Output (indicative) - P_{min}	1.6kW	1.5kW	1.4kW	1.4kW

Auxiliary Electricity Consumption	At Nominal Heat Output - e_{lmax}	N/A	N/A	N/A	N/A
	At Minimum Heat Output - e_{lmin}	N/A	N/A	N/A	N/A
	In Standby Mode - e_{sb}	N/A	N/A	N/A	N/A

Useful Efficiency (NCV)	Useful Efficiency at nominal heat output - $\eta_{th,nom}$	86.0%	86.0%	86.0%	86.0%
	Useful Efficiency at minimum heat output (indicative) - $\eta_{th,min}$	76.0%	76.0%	76.0%	76.0%

Permanent Pilot Flame Power requirement	Permanent Pilot Flame Power requirement (if applicable) - P_{pilot}	0.200kW	0.200kW	0.200kW	0.200kW
---	---	---------	---------	---------	---------

Type of heat output/room temperature control - Manual Control					
	Electronic thermostat + day timer	Yes*	Yes*	Yes*	Yes*

Other control options (multiple selections possible)					
	Room temperature control, with presence detection	No	No	No	No
	Room temperature control, with open window detection	No	No	No	No
	With distance control option	No	No	No	No
	With adaptive start control	No	No	No	No
	With working time limitation	No	No	No	No
	With black bulb sensor	No	No	No	No

Energy Efficiency Index	78.9%	78.9%	78.2%	78.3%
Energy Efficiency Class	C	C	C	C

Contact:	Gazco Ltd, Osprey Road, Sowton Industrial Estate, Exeter, EX2 7JG
----------	---

* Achievable using Thermostatic and Timer Remote Control upgrade kit, part number 8456.

Information Requirement - Gas Heaters

Information Requirement for Gaseous Fuel Local Space Heater

Model		Logic HE BF Slide Control NG Coal	Logic HE BF Slide Control LPG Coal	Logic HE BF Slide Control NG Stones	Logic HE BF Slide Control LPG Stones
Fuel	Space Heating Emissions (NOx) - mg / kWh _{input} (GCV)	130	130	130	130

Heat Output	Nominal Heat Output - P_{nom}	3.2kW	3.2kW	2.6kW	2.7kW
	Minimum Heat Output (indicative) - P_{min}	1.6kW	1.5kW	1.4kW	1.4kW

Auxiliary Electricity Consumption	At Nominal Heat Output - e_{lmax}	N/A	N/A	N/A	N/A
	At Minimum Heat Output - e_{lmin}	N/A	N/A	N/A	N/A
	In Standby Mode - e_{lsb}	N/A	N/A	N/A	N/A

Useful Efficiency (NCV)	Useful Efficiency at nominal heat output - $\eta_{th,nom}$	86.0%	86.0%	86.0%	86.0%
	Useful Efficiency at minimum heat output (indicative) - $\eta_{th,min}$	76.0%	76.0%	76.0%	76.0%

Permanent Pilot Flame Power requirement	Permanent Pilot Flame Power requirement (if applicable) - P_{pilot}	N/A	N/A	N/A	N/A
---	---	-----	-----	-----	-----

Type of heat output/room temperature control - Manual Control					
	Two or more manual stages, no room temperature control	Yes	Yes	Yes	Yes

Other control options (multiple selections possible)					
	Room temperature control, with presence detection	No	No	No	No
	Room temperature control, with open window detection	No	No	No	No
	With distance control option	No	No	No	No
	With adaptive start control	No	No	No	No
	With working time limitation	No	No	No	No
	With black bulb sensor	No	No	No	No

Energy Efficiency Index	77%	77%	77%	77%
Energy Efficiency Class	C	C	C	C

Contact:	Gazco Ltd, Osprey Road, Sowton Industrial Estate, Exeter, EX2 7JG
----------	---

Gazco Limited, Osprey Road, Sowton Industrial Estate, Exeter, Devon, England EX2 7JG
Technical Customer Services: (01392) 261950 Fax: (01392) 261951
E-mail: technicalservices@gazco.com

A member of the Stovax Group
E & O E