

STOVAX

Fire Your Imagination

Studio

Freestanding Range



Instructions for Use, Installation & Servicing

For use in GB & IE (Great Britain & Republic of Ireland).

This edition incorporates PM400 Issue 4 for the purposes of installation in Smoke Control Areas.

IMPORTANT

THE OUTER CASING, FRONT AND GLASS PANEL BECOME EXTREMELY HOT DURING OPERATION AND WILL RESULT IN SERIOUS INJURY AND BURNS IF TOUCHED. IT IS THEREFORE RECOMMENDED THAT A FIREGUARD COMPLYING WITH BS 8423 (LATEST EDITION) IS USED IN THE PRESENCE OF YOUNG CHILDREN, THE ELDERLY OR INFIRM.

Do not attempt to burn rubbish in this appliance.

Please read these Instructions carefully before installation or use.

Keep them in a safe place for future reference and when servicing the fire.

The commissioning sheet found on page 3 of these instructions should be completed by the Installer.

Contents

Studio - Freestanding

Covering the following models:

RVFST-500/RVFST-1HT/RVFST-2HT/RVFST-3HT

Appliance Commissioning Checklist	3
User Instructions	4
Getting Started	4
User Instructions	6
Care & Maintenance.....	9
Troubleshooting	12
Installation Instructions	14
Installation Checklist.....	14
Pre-Installation Instructions	19
Installing the Appliance.....	22
Commissioning	29
Maintenance & Servicing	31
Technical Appendix	35
Information Requirement - Solid Fuel	39
Spare Parts List.....	40
Service Records	44



If you have purchased your stove or fire from an authorised stockist within our Expert Retailer Network, then automatically your product will carry a 2 year warranty as standard. The 2 year warranty can be further extended to a total warranty period of 5 years by registering your Stovax Stove or Fireplace within one month of the latter of the purchase date or installation date. Accordingly, the start date for the warranty period is the date of purchase. During the registration process, the Expert Retailer details will be required for your Extended Warranty to be activated. Any product purchased outside of our Expert Retailer Network will carry a standard 12 month, non-extendable warranty.

It is a condition of the Extended Warranty that the installation complies with the relevant Building Regulations and is carried out by a suitably trained and qualified individual (HETAS in the UK or equivalent in other countries) with the certificate of installation and the Commissioning Report on Page 3 completed and retained by the end user.

Full terms and conditions are detailed in the Warranty Statement on the Stovax website www.stovax.com. In the event of any conflict of information the wording on the website shall prevail.

Important Note: Should any problems be experienced with your product, claims must first be submitted to the Expert Retailer where the appliance was purchased from who will offer immediate assistance or contact Stovax on your behalf.

DESIGN PROTECTION

The Studio design, including it's frames and accessories, are protected by European Design Registration
No. 001169338 0002 0008.

Appliance Commissioning Checklist

To assist us in any guarantee claim please complete the following information:-

Dealer appliance was purchased from:

Name:

Address:

Telephone number:

Essential information - MUST be completed:

Date Installed:

Model Description:

Serial Number:

Installation Engineer:

Company Name:

Address:

Telephone number:

Commissioning Checks - to be completed and signed:

Is flue system correct for the appliance:	YES <input type="checkbox"/>	NO <input type="checkbox"/>
Flue swept and soundness test complete:	YES <input type="checkbox"/>	NO <input type="checkbox"/>
Smoke test completed on installed appliance	YES <input type="checkbox"/>	NO <input type="checkbox"/>
Spillage test completed	YES <input type="checkbox"/>	NO <input type="checkbox"/>
Use of appliance and operation of controls explained	YES <input type="checkbox"/>	NO <input type="checkbox"/>
Clearance to combustible materials checked	YES <input type="checkbox"/>	NO <input type="checkbox"/>
Instruction book handed to customer	YES <input type="checkbox"/>	NO <input type="checkbox"/>
CO Alarm Fitted	YES <input type="checkbox"/>	NO <input type="checkbox"/>

Signature: Print Name:

Getting Started

Welcome

Congratulations on purchasing your Stovax Studio, if installed correctly Stovax hope it will give you many years of warmth and pleasure for which it was designed.

The purpose of this manual is to familiarise you with your stove, and give guidelines for its installation, operation and maintenance. If, after reading, you need further information, please do not hesitate to contact your Stovax retailer.

1. General Points

- 1.1 Before installation and/or use of this appliance please read these instructions fully and carefully to ensure that you have fully understood their requirements.

The appliance must be fitted by a registered installer*, or approved by your local building control officer.

- 1.2 All local regulations, including those referring to national and European Standards need to be complied with when installing the appliance.
- 1.3 Only use for domestic heating in accordance with these operating instructions.
- 1.4 You must burn only approved fuels. Do not use with liquid fuels or as an incinerator.
- 1.5 Appliance surfaces become very hot when in use. Use a suitable fireguard[‡] if young children, elderly or infirm persons are present. Stovax offer firescreens, sparkguards and hearthgate systems for protection*. Your Stovax dealer can advise you about these products.
- 1.6 Do not place photographs, TV's, paintings, porcelain or other combustible items on the wall or near the appliance. Exposure to hot temperatures will cause damage. Do not place furniture or other items such as drying clothing closer than 1m from the front of this appliance.

WARNING: Extra fuel should not be stored on or next to the appliance. Only keep enough fuel for immediate use nearby and never leave the appliance unattended for long periods with any combustible material in close proximity.

- 1.7 Extractor fans or cooker hoods must not be placed in the same room or space as this can cause appliance to emit fumes into the room.
- 1.8 Do not obstruct inside or outside ventilation required for the safe use of this appliance.
- 1.9 Do not make unauthorised changes to the appliance.



‡In the U.K. these products must conform to the latest edition of BS 8423, Fireguards for use with solid fuel appliances. If appliance is operating unattended they must conform to the latest edition of BS 3248

***Registered on the Competent Persons Scheme (GB only see page 38/ INFO (Republic of Ireland)).**

- 1.10 The chimney must be swept at least once a year, see Section 13.
- 1.11 Do not connect, or share, the same flue or chimney system with another appliance.

SERIAL NUMBER

- 1.12 This number is required when ordering spare parts or making warranty claims.

It is found on the appliance data plate, see Diagram 1.

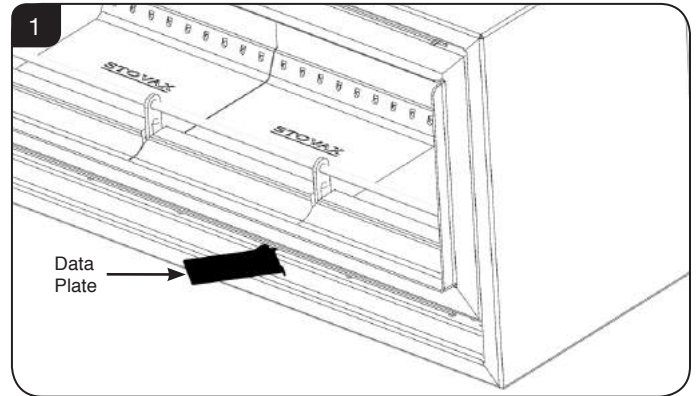

AIR CONTROLS

Triple Air Systems

Several Stovax appliances have triple air systems providing cleaner burning, and greater efficiency and control, see Diagram 2.

- 1) Airwash - air drawn over the window cleans the glass. The source of Primary Combustion air when burning wood.
- 2) Primary Air - for use initially when establishing fires.
- 3) Secondary Air - Secondary air is preheated through a heat exchanger to combust unburned hydrocarbons, providing a cleaner and more efficient burn.

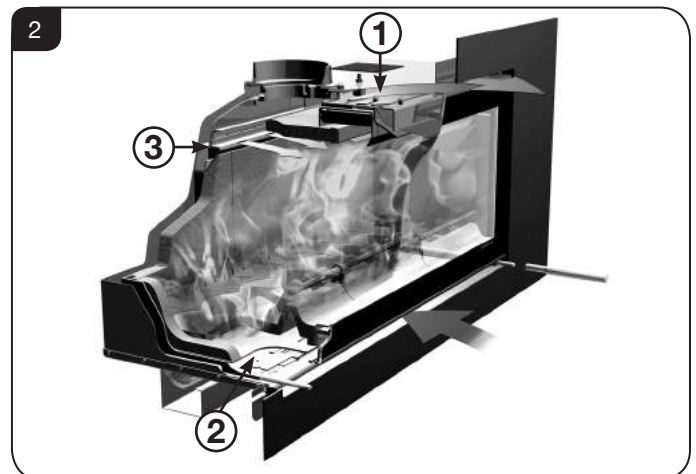

Getting Started

Airwash and Primary Air Controls Studio 500 1,2,3

i **IMPORTANT:** Stovax provide gauntlet style gloves for the users protection from heat and any sharp edges when using the appliance. For your safety ensure that gloves are always worn when opening, operating, refuelling or handling internal metalwork.

1.13 Use a protective gloved hand to operate.

DO NOT OPERATE THE AIR CONTROLS WITH BARE HANDS

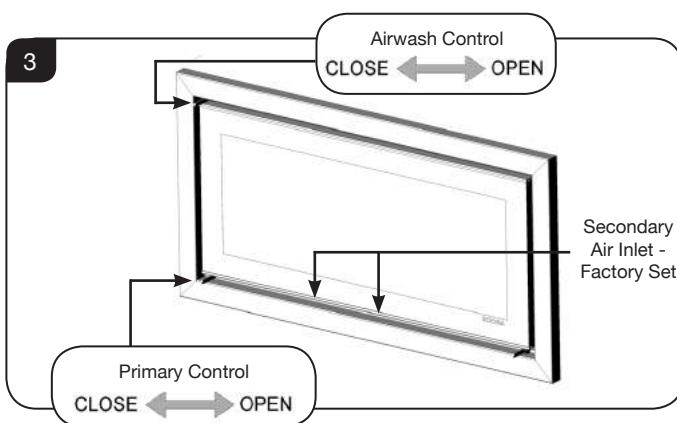

i **NOTE:** The travel of the Airwash control and Primary control may be limited if the appliance has been set up to operate in a Smoke Control Area.

DOOR HANDLE

DO NOT OPEN THE DOOR WITH BARE HANDS

DO NOT OPEN THE DOORS WHEN THE FIREBOX IS FULL OF FLAMES - WAIT FOR THEM TO DIE DOWN.

Studio 500, 1 & 2

1.14 Use a protective gloved hand to operate. Slide tool over knob to fit.

1.15 Move the slider to the left to open, see Diagram 4.

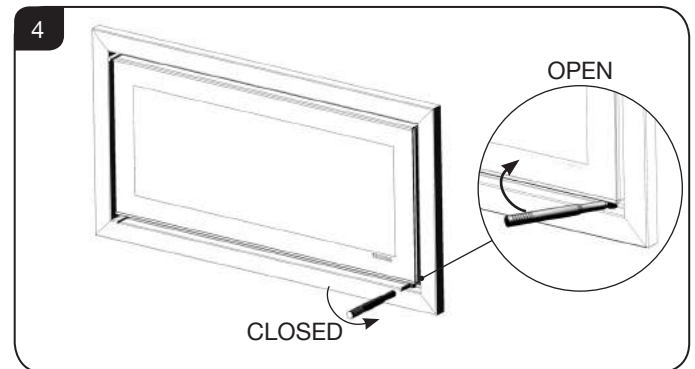

Studio 3

1.16 Engage tool in door as shown, see Diagram 5. Pull door out and down to open.

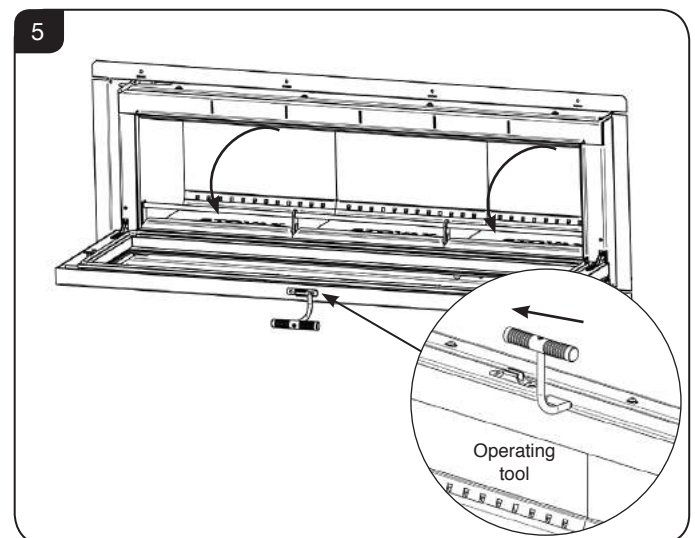

Getting Started/User Instructions

WARNING



Properly installed, operated and maintained this appliance will not emit fumes into the room but occasional fumes from de-ashing and refuelling may occur.

Persistent fume emission is potentially dangerous and must not be tolerated.

If fume emission persists:

- Open doors and windows to ventilate the room.
- Leave the room.
- Allow fire to burn out or safely dispose of fuel from the appliance.
- Check for chimney blockage and clean if required.
- Do not attempt to relight until the cause of the emission has been identified and corrected.
- If necessary seek expert advice.
- All open flued appliances can be affected by temporary atmospheric conditions which may allow fumes to enter the house. Because of this an electronic carbon monoxide detector conforming to the latest edition of BSEN50292 must be fitted in the same room as the appliance. The existence of an alarm must not be considered a substitute for ensuring regular servicing and maintenance of the appliance and chimney system.

IF THE ALARM SOUNDS FOLLOW THE INSTRUCTIONS GIVEN ABOVE.

2. Using the Appliance for the First Time

- 2.1 To allow the appliance to settle, and fixing glues and paint to fully cure, operate the appliance at a low temperature for first few days.
- 2.2 Do not touch the paint during the first period of use.
- 2.3 During this time the appliance may give off some unpleasant odours. Keep the room well ventilated to avoid a build-up of fumes.
- 2.4 Please be aware that, during use, rope seals may discolour. This is normal.

3. Recommended Fuels

3.1 Wood Logs:

Burn only seasoned timber with a moisture content of less than 20%. To ensure this allow cut wood to dry for 12 to 18 months.

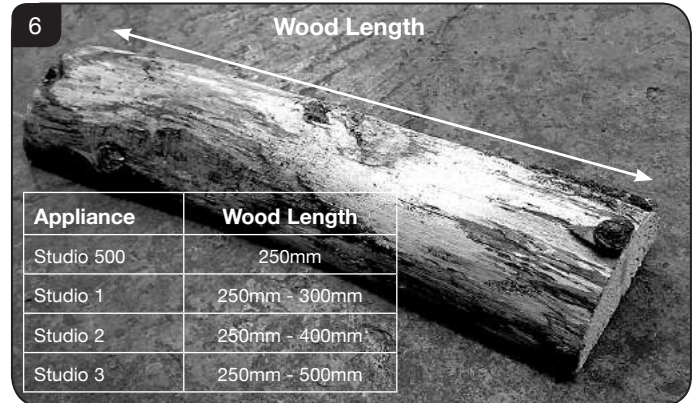

Poor quality timber:

- Causes low combustion efficiency
- Produces harmful condensation
- Reduces effectiveness of the airwash and life of the appliance

Do not burn construction timber, painted, impregnated / treated wood, manufactured board products or pallet wood.

3.2 Fuel consumption.

As tested at nominal heat output to the requirements of EN 13240: 2001 for intermittent operation:

Description	Fuel Consumption
	Kg/hour Wood
Studio 500	1.4
Studio 1	1.6
Studio 2	2.4
Studio 3	3.6

A number of factors can affect the performance of the appliance. See *Troubleshooting Section* for details.

Fuel Overloading

The maximum amount of fuel specified in this manual should not be exceeded, overloading can cause excess smoke.

User Instructions

4. Smoke Control Kit

This section applies to the Studio products listed:

Product Code	Appliance
RVFST-500	Studio Freestanding 500
RVFST-1HT	Studio Freestanding 1
RVFST-2HT	Studio Freestanding 2

- 4.1 The Studio models listed are supplied with a pre-fitted smoke control kit and have been independently tested to PD6434 making them exempt from the controls that generally apply in Smoke Control Areas.
- 4.2 These models are suitable for use in a Smoke Control Area when burning wood and following the instructions for use specified in this manual but ONLY if the Smoke Kit has not been removed.
- 4.3 If fitted, the Smoke Control kit can be seen in the following locations, see Diagrams 7 & 8.

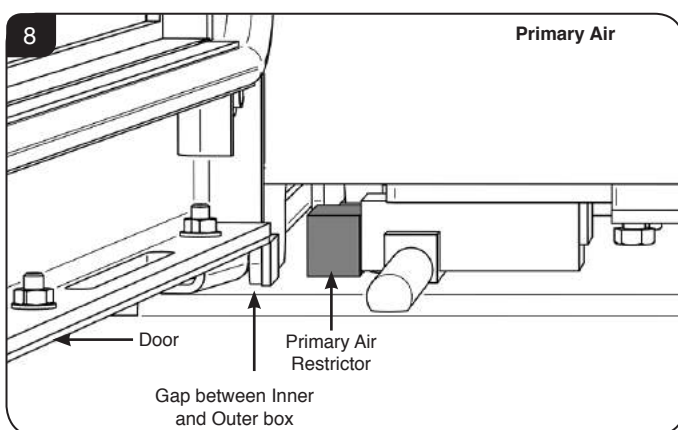
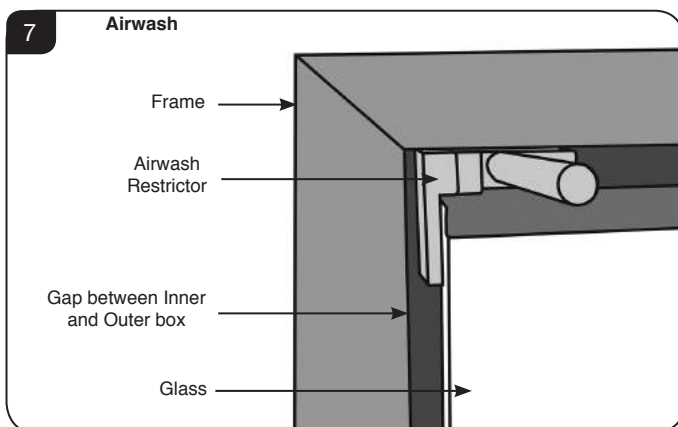

- 4.4 To meet the requirements of a Smoke Control Area the appliance MUST be operated correctly in order to minimise the amount of smoke produced.



If these Studio models are installed outside of a Smoke Control Area then the Smoke Control kit can be removed to give more control over the lower burn rates. Removing the kit should only be done by a suitably qualified installer and must be done at the time of installation.

These instructions must be left with the User.

5. Lighting the Appliance



IMPORTANT: Stovax provide gauntlet style gloves for the users protection from heat and any sharp edges when using the appliance. For your safety ensure that gloves are always worn when opening, operating, refuelling or handling internal metalwork.

- 5.1 For best results set air controls as shown, see Diagram 9.

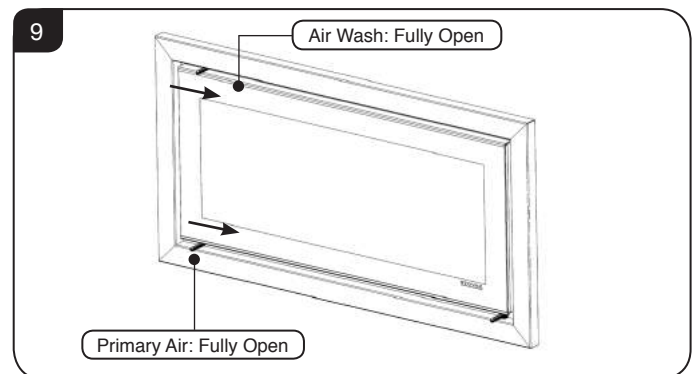

- 5.2 Place firelighters or paper and dry kindling wood on the base bricks.

A successful fire initially requires plenty of kindling to establish a hot firebox and warm the chimney to aid flue performance.

- 5.3 Light the paper or firelighters, see Diagram 10.
- 5.4 Leave the door slightly open as the fire establishes and the glass warms to avoid build up of condensation.

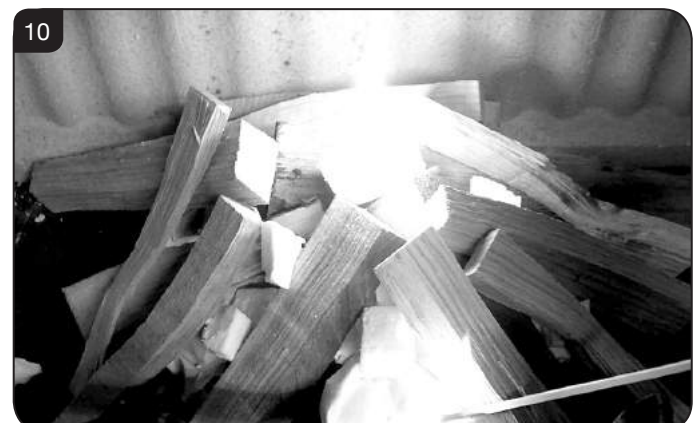

User Instructions

- 5.5 Add larger pieces of wood.
Do not use full sized logs at this stage, build up gradually in size. Too many logs may smother the fire.

Fuel Loading:

These are wide appliances and the logs should be laid out in a single layer with gaps between, see Diagram 11.

**Do not stack the logs on top of each other as this could effect the efficiency.
DO NOT OVERLOAD THE APPLIANCE AS THE HEAT OUTPUT WILL BE TOO HIGH.**

Be sure to use split logs and not whole pieces of wood. Too much fuel in the firebox will cause the appliance to reach higher temperatures than intended. This can damage the interior components of the fire.

Suggested Loads:

Studio 500 - 2/3 logs no bigger than 5" (127mm) diameter
Studio 1 & 2 - 3/4 logs no bigger than 5" (127mm) diameter
Studio 3 - 4/5 logs no bigger than 5" (127mm) diameter

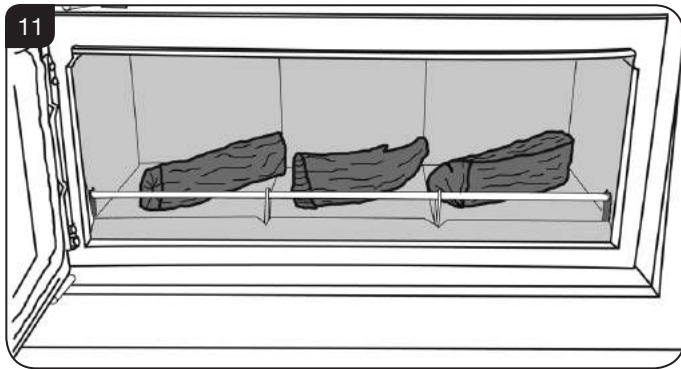

- 5.6 Close the door and follow the instructions for Running the Appliance.
Do not run with the door slightly open except for initial lighting as this could cause over-firing and damage the appliance.

WARNING: DO NOT OPERATE THE APPLIANCE WITH THE PRIMARY AIR CONTROL OPEN FOR LONG PERIODS OF TIME AS THIS COULD CAUSE OVER-FIRING AND MAY CAUSE PERMANENT DAMAGE.

6. Running the Appliance

Burning Wood

- 6.1 Close the **Primary air control** and use the **Airwash** to control the burn rate when appliance is at operating temperature, see Diagram 12.

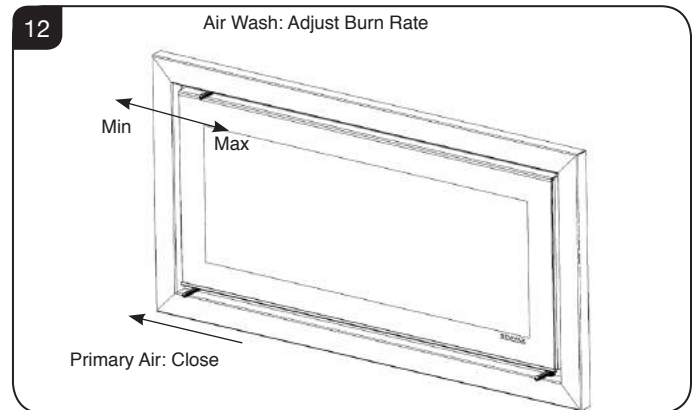

Wood burns best on a bed of ash (approx. 25mm (1") deep).

- 6.2 Do not burn large amounts of fuel with the **Airwash Control** closed for long periods of time. This reduces the glass cleaning effect of the Airwash and causes tars and creosotes to build-up in the appliance and flue system.
- 6.3 When in use, burning the appliance at a high temperature for a short period reduces tars and creosotes.
WARNING: DO NOT OPERATE THE APPLIANCE WITH THE PRIMARY AIR CONTROL OPEN FOR LONG PERIODS OF TIME AS THIS COULD CAUSE OVER-FIRING AND MAY CAUSE PERMANENT DAMAGE.

Experience establishes settings to suit personal preference.

Refuelling

- 6.4 Open the Primary Air and Airwash controls fully.
- Rake the embers evenly over the firebed to establish a glowing firebed. If the firebed is low add a small amount of kindling wood to help re-establish the fire.**
- 6.5 **Do not refuel when a large amount of flames are in the firebox as this could cause smoke or flames to spill into the room.**
- 6.6 **Close the doors immediately after refuelling.**

These are wide appliances and the logs should be laid out in a single layer with gaps between, see Diagram 11.

**Do not stack the logs on top of each other as this could effect the efficiency.
DO NOT OVERLOAD THE APPLIANCE AS TOO MUCH FUEL COULD CAUSE IT TO OVER-FIRE.**

Care & Maintenance

- 6.7 After refuelling:
Burn the new logs at high output for a few minutes before closing the Primary Air control. Adjust the burn rate using the Airwash control.

Do not close the air controls until the fire is burning well.

- 6.8 **Do not** burn large amounts of fuel with the **Airwash control** closed for long periods of time. This reduces the glass cleaning effect, causes tars and creosotes to build-up in the appliance and flue system and will produce excessive amounts of smoke.

- 6.9 When running the appliance **refuel little and often for clean, efficient burning.**

A bright and clean firebox indicates the appliance is burning well.

- 6.10 **Do not burn continuously with the door open.**

Shut Down

- 6.11 If there is still burning fuel in the firebox, Stovax do not recommend shutting down the air controls completely unless there is a chimney fire in progress (see Section 9 for advice). Closing the controls during the burning process will cause poor combustion and could lead to a build up of gasses that could ignite dangerously.
- 6.12 Always have enough air entering the stove to maintain some flame within the firebox.
- 6.13 If it is necessary to shut down the appliance then run on a high setting until all of the fuel has been burnt before closing the air controls.

7. Extended Burning

- 7.1 It is possible to get the appliance to burn for extended periods of time. In order to do this:
- De-ash prior to final refuelling.
 - Burn new fuel at a high temperature for a few minutes before closing the **Primary Air Control**.
 - Set Airwash to low combustion settings.
This will gradually blacken the glass but it will clear when operated at a high temperature for a short period.

NOTE: An appliance without a Smoke Control kit fitted will burn longer than an appliance that complies to the restrictions of a Smoke Control Area, see Section 4.

8. Ash Removal

- 8.1 Wood burns best on a bed of ash.
Do not allow ash to build up in the appliance as it will not burn properly and may cause damage.
- 8.2 Open door, see Diagrams 4&5 on page 5.
Remove ash with a small shovel (available from Stovax).
Take care not to damage the ceramic lining of the appliance.
Do not use sharp pointed pokers.
- 8.3 Remove ash carefully - heat can remain long after use.
- 8.4 Carefully place the ash into a Stovax Ash Caddy (Stovax Part No. 4227).
- 8.5 **Do not place hot ash in a container made from plastic or any other combustible material.**

9. Over-Firing

- 9.1 Do not over-fill with fuel or run at high temperatures for long periods or over-firing can occur.
DO NOT OPERATE THE APPLIANCE WITH THE PRIMARY AIR CONTROL OPEN FOR LONG PERIODS OF TIME AS THIS COULD CAUSE OVER-FIRING AND MAY CAUSE PERMANENT DAMAGE.
- 9.2 **Over-firing can cause permanent damage to the appliance and invalid the product warranty.**

10. Chimney Fire

- 10.1 **If a chimney fire occurs:**
- Shut all air controls immediately.
 - Evacuate the building.
 - Call the fire brigade.
 - Do not re-enter the building until it is confirmed safe.
- 10.2 **Do not use the appliance after a chimney fire until:**
- a) It has been inspected by a registered installer*, confirming the appliance is safe to use.
 - b) The chimney system has been inspected and swept by a chimney sweep, confirming the system is structurally sound and free from obstruction*.
 - c) **It is repaired as required before re-use.** Use only genuine Stovax replacement parts to keep your appliance in safe, efficient working order.



*Registered on the Competent Persons Scheme (GB only) see page 38/ INFO (Republic of Ireland).

Care & Maintenance

11. General Cleaning

- 11.1 Clean and inspect the appliance regularly, especially in periods of heavy use. Regular cleaning and maintenance will help give many years of safe use.
- 11.2 **Allow appliance to cool thoroughly to avoid risk of burns.**
- 11.3 Clean regularly, according to level of use.
- 11.4 Remove the ash completely (see *User Instructions, Section 8*).
- 11.5 Check internal components for damage - grates, bricks, baffles - and for obvious build up of soot, ash or debris above the flue baffle(s) (these can be found in the upper part of the firebox). Use a torch if necessary.
- 11.6 If there are any signs of a build up of debris above the flue baffle(s) either:
 - Arrange for the chimney to be swept (see *User Instructions, Section 13*).
 - Remove the baffles and clear the debris (see *Pre-Installation Sections*).
- 11.7 To refresh painted finishes a touch up spray is available. Contact your Stovax retailer quoting the serial number found on the appliance data badge.

Do not use aerosol sprays near an operating appliance.

12. Cleaning Glass

- 12.1 Keep the glass clean with correct use of the Airwash system and good quality fuel.
- 12.2 Sometimes additional cleaning may be required. Before undertaking this operation allow appliance to cool fully. Do not clean hot glass.
- 12.3 **On appliances with printed glass do not use cleaning agents that have a high alkaline or acidic content, for example Stovax Gel Cleaner, these are aggressive cleaning agents designed to be used with heavily stained clear glass. On printed glass surfaces, use Stovax Glass Cleaner (Stovax No.4103) which is better formulated for this application.**
- 12.4 Before applying a cleaning agent remove any dust and loose soot with a damp cloth.
- 12.5 Use an appropriate glass cleaner. Apply the cleaning fluid to a cloth before rubbing onto the glass. Apply carefully and do not apply excessively. Try to prevent any run off which could soak into the rope seals around the edge of the glass. Soot can also contain acidic particles that can cause corrosive damage to printed glass.
- 12.6 Remove dirt with a moist cloth and buff dry.

- 12.7 **Some types of wood can cause a white residue to form on the glass. If this occurs it should be cleaned off at least once a week during periods of heavy usage. If the liquid cleaning agents recommended do not remove this residue Stovax offer a dry cleaning pad which will help remove heavy stains.**
- 12.8 Before relighting the appliance ensure the glass is fully dried. If the rope seal has absorbed excess cleaning agent it is advisable to replace the rope as soon as possible to preserve the printed finish of the glass.

13. Chimney Sweeping

- 13.1 To maintain safe and efficient use of the appliance, the chimney/flue must be inspected and swept at least once a year by a qualified chimney sweep*.

If the appliance is used continuously throughout the year, or it is used to burn wood, more frequent sweeping is recommended.

The best time to have the chimney swept is at the start of the heating season.
- 13.2 The chimney, any connecting flue pipe and the appliance flue ways, if incorporated, must be regularly cleaned.
- 13.3 Ensure adequate access for cleaning where it is not possible to sweep through the chimney.
- 13.4 If the chimney is believed to have previously served an open fire it must be swept a second time within a month of regular use after installation.

14. Care Of Stove

Stovax has a range of cleaning and maintenance products and accessories to keep your appliance in good working order. Your Stovax retailer can advise you on suitable items for your stove and provide genuine spare parts such as replacement glass, door sealing rope and firebricks. View the extensive range at www.stovax.com by clicking on *Accessories*. In addition, an annual service by a competent engineer is recommended to keep your stove in the best possible condition.



*Registered on the Competent Persons Scheme (GB only) see page 38/ INFO (Republic of Ireland).

15. Seasonal Use

- 15.1 Clean and service the appliance if not used during the warmer months, as detailed in the *Maintenance and Servicing* section.
- 15.2 Set the air controls to 50% to keep the appliance ventilated and stop the build-up of any moisture inside.
- 15.3 Before re-lighting the appliance:
- Remove the baffles.
 - Clear any debris that may have accumulated.
 - Check the flue is clear of any blockages.

16. Optional Extras

Decorative Flue Cover

- 16.1 This appliance can be fitted with an optional decorative flue cover. For installation procedures please refer to the instructions supplied with the kit.

Outside Air Kit

- 16.2 This appliance can be fitted with an optional kit to help bring air directly into the appliance from outside. The For installation and operating procedures you must refer to the instructions supplied with the Outside Air kit.

Bench

- 16.3 This appliance can be fitted with a bench, various sizes are available. This must be done at the time of installation. Please refer to instructions.

Heat Shield

- 16.4 This appliance can be fitted with a heat shield in order to decrease the distance the appliance can be installed from a wall. This must be done at the time of installation. Please refer to instructions.

Glass Top Plate

- 16.5 This appliance can be fitted with a decorative glass top plate. This must be done at the time of installation. See installation instructions, Section 6.

Troubleshooting

Troubleshooting

	Symptom	Cause	Solution
OPERATION	Difficulty starting the fire and keeping it burning well	Low flue draught	Consult your installer
		Wet wood (over 20% moisture)	Use dry seasoned wood (less than 20% moisture content)
	Poor burning control	High flue draught	Consult your installer
	Short burn times	Wet wood (over 20% moisture) Insufficient amount of fuel - Refer to the table in section 3	Use dry seasoned wood (less than 20% moisture content)
	Excessive heat output (Over firing)	High flue draught	Consult your installer
		Air control left fully open	Close air control to reduce output
	Low heat output	Low flue draught	Consult your installer for advice on suitable flue system
		Wet wood (over 20% moisture)	Use dry seasoned wood (less than 20% moisture content)
Excessive fuel consumption	High flue draught	Consult your installer for advice on suitable flue system	
	Over dry wood	Do not use constructional timber or pallet wood	
SMOKE EMISSIONS	Smoke and small flames	Wet wood (over 20% moisture)	Use dry seasoned wood (less than 20% moisture content)
	Intermittent smoke spillage into room when appliance door is opened	Low flue draught	Consult your installer for advice on suitable flue system
		Incorrect additional ventilation air in to building	Consult your installer
	Continuous smoke spillage into room when appliance in use	Blocked flue	Open all doors and windows to ventilate the room. Allow the fire to burn out. Check flue for blockage. Do not re-use until cause of spillage is identified. Consult your installer for advice
Blue/grey smoke from chimney	Wet wood (over 20% moisture)	Use dry seasoned wood (less than 20% moisture content)	
ADVERSE WEATHER	Windy days, intermittent smoke spillage into room when appliance door is opened	Down draught in flue caused by air turbulence caused by nearby buildings or trees	Weather conditions combined with the flue terminal position can have an effect on the appliance performance. Consult your installer
	Calm days, intermittent smoke spillage into room when appliance door is opened	Over size flue giving poor flue draught	Weather conditions combined with the flue terminal position can have an effect on the appliance performance. Consult your installer
	Damp/Rainy days lighting and burning problems	Flue temperature low / rain water inside flue	Use good quality wood to start and maintain the fire, consult your installer to fit a rain cowl
	Wind noise from the air control	High flue draught	Consult your installer for advice on suitable flue system

Troubleshooting

	Symptom	Cause	Solution
THE APPLIANCE	Rapid creosote build-up in the chimney	Wet wood (over 20% moisture)	Use dry seasoned wood (less than 20% moisture content). Operate at a high temperature for short periods each time the appliance is used to avoid large build-ups of tars and creosotes
	Tar coming from flue joints	Appliance operated at continuous low temperatures	Operate at a high temperature for short periods each time the appliance is used to avoid large build-ups of tars and creosotes. See user instructions for correct use of air control
		Using poor quality wood	Use dry seasoned wood (less than 20% moisture content)
	Strong pungent smell after the appliance is lit	Appliance operated at continuous low output	Operate at high output for short periods. See user instructions for correct use of air control
		Using poor quality wood	Use dry seasoned wood (less than 20% moisture content)
	Wind noise from the air control	High flue draught	Consult your installer for advice on suitable flue system
	Dirty firebricks	Wet wood (over 20% moisture)	Use dry seasoned wood (less than 20% moisture content)
	Dirty glass	Wet wood (over 20% moisture)	Use dry seasoned wood (less than 20% moisture content)
	Glass blackening	Using poor quality wood	Use dry seasoned wood (less than 20% moisture content)
		Low flue draught	Consult your installer for advice on suitable flue system
Incorrect use of air control		See user instructions for correct use of air control	
Appliance operated at continuous low temperatures		Operate at high output for short periods. See user instructions for correct use of air control	

FLUES	The flue system has two main functions:
	<ul style="list-style-type: none"> - To safely remove the smoke, fumes and combustion gases from the building. - To provide a sufficient amount of flue draught (suction) in the appliance to ensure the fire keeps burning.
	The flue draught is caused by rising hot gases when the appliance is lit.
	Tar and creosote are a major cause of chimney fires. If the appliance experiences problems with tar build up consult a chimney sweep before continued use of the appliance.
	For advise on the correction of persistent flue problems consult a qualified heating engineer before continuing to use the appliance.

Installation Checklist

Please Note

This section is intended to give an overview of the product performance and essential information required for installing the appliance. It is intended for qualified engineers who are already familiar with Stovax products.

For full details and expanded information please see the Technical Appendix at the back of this manual.

1. Studio Dimensions

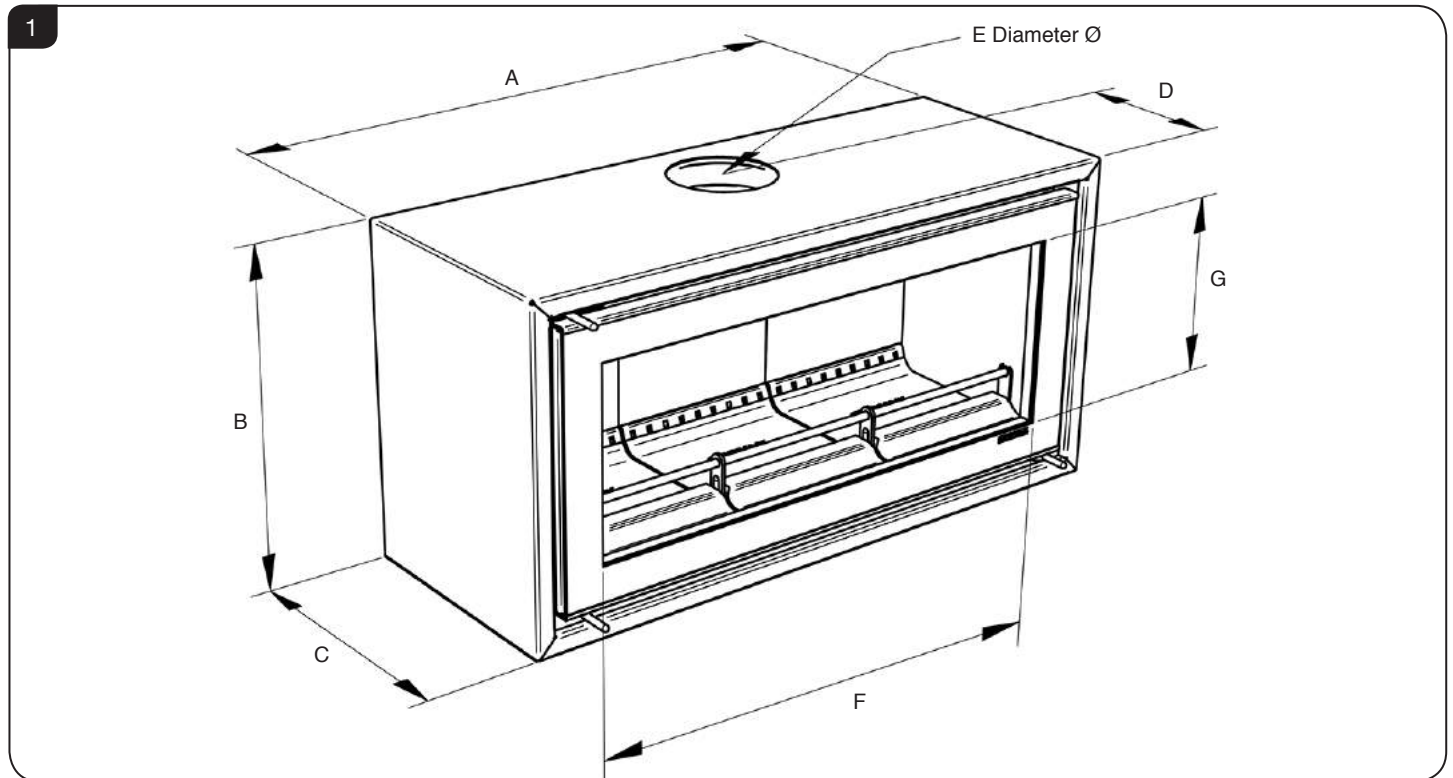

Description	Model	A	B	C	D	E	F Glass Viewing Area	G Glass Viewing Area
Studio 500	RVFST-500	607	479	382	260	153	397	263
Studio 1	RVFST-1HT	800	479	380	260	153	590	263
Studio 2	RVFST-2HT	1000	504	380	260	153	790	289
Studio 3	RVFST-3HT	1389	516	445	325	153	1177	286

All dimensions in mm (25.4 mm = 1")

Installation Checklist

2. Essential Information

GENERAL	Model: Studio 500 Studio 1 Studio 2 Studio 3			Studio 500	Studio 1	Studio 2	Studio 3	
	Nominal Heat Output	Wood	kW	4.9	5.0	8.0	11.0	
	Efficiency	Wood	%	80.0	74.6	75.3	75.6	
	CO @ 13% O ₂	Wood	%	0.290	0.230	0.180	0.247	
	Weight		Kg	85	100	120	192	
Recommended Fuels	Wood	Seasoned Wood (less than 20% moisture content)						

As tested to the requirements of EN 13240 for intermittent operation

FLUES	Flue/Chimney Size	With Liner of Factory made system (diameter) installed in accordance with manufacturers instructions	mm	153	153	153	153	
			inch	6	6	6	6	
	Flue/Chimney minimum height	All products	m	4.5	4.5	4.5	4.5	
			feet	15	15	15	15	
	Flue Draught	Min	mm Wg		1.0	1.0	1.0	1.0
		Nominal			1.5	1.5	1.5	1.5
		Max			2.0	2.0	2.0	2.0
Flue Gas Mass Flow	Wood	g/s	3.9	5.5	6.6	8.6		
Flue Gas Temperature at Spigot/Socket	Wood	°C	265	301	346	352		
Flue Outlet Size (Top Option)		mm	153	153	153	153		
		inch	6	6	6	6		

European Min Spec for Chimney Flue - T400 N2 D3 G50

VENTILATION	A) Traditionally Built Homes • Where leakage is greater than 5m ³ /hour/m ² . • Ventilation normally required = 550mm ² per kW output over 5kW		B) Modern Construction Homes • Where leakage is less than 5m ³ /hour/m ² . • Ventilation normally required = 550mm ² per kW				
	A	Additional Ventilation	mm ²	None	None	1650	3300
			cm ²	None	None	16.5	33
			in ²	None	None	2.6	5.3
	B	Additional Ventilation	mm ²	2695	2750	4400	6050
			cm ²	26.9	27.5	44	60.5
in ²			4.35	4.44	7.1	9.76	

For full technical details on ventilation see Technical Appendix on Page 37

i In the U.K. Additional information covering the installation of the appliance may be found in the following British Standards: BS EN 15287, BS6999, BS8303.

Installation Checklist

3. Minimum Dimensions - Hearth

3.1 Hearth construction must comply with the building regulations in force. The appliance must stand on a non-combustible constructional hearth which is at least 125mm thick with the minimum dimensions as shown in Diagram 2.

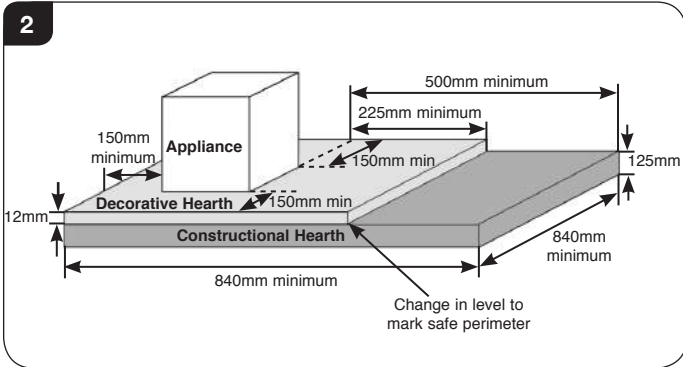

If this appliance is installed on a Stovax Bench, the bench may stand on a 12mm thick non-combustible hearth and it is recommended that the 225mm hearth depth should be increased to safely contain any falling logs or embers, see Diagram 3.

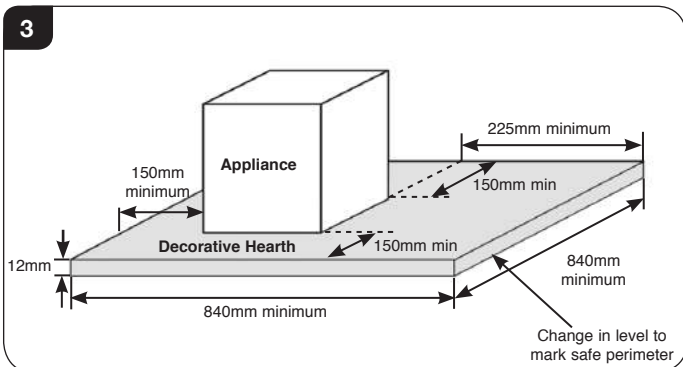

3.2 If this appliance is installed in an elevated setting it is recommended to increase the 225mm hearth depth to safely contain any falling logs or embers. The higher the appliance is installed the deeper the hearth should be to avoid scorched floor coverings.

i † England and Wales – Document J / Scotland - Part F/Document J (Republic of Ireland only)

4. Clearances



IMPORTANT: INSTALLATION MUST COMPLY WITH CURRENT BUILDING REGULATIONS

ENSURE THAT SUFFICIENT CLEARANCES ARE PROVIDED BETWEEN THE FLUE PIPE AND ANY COMBUSTIBLE MATERIALS IN THE FIREPLACE IN ACCORDANCE WITH THE RULES IN FORCE.†

4.1 When installing the appliance it is important to observe the following clearances to both **combustible** and **non-combustible** materials. Also ensure that a clearance of 1 meter is maintained in front of the appliance when operating.

Fireplace: Minimum Clearances Above & to the Sides

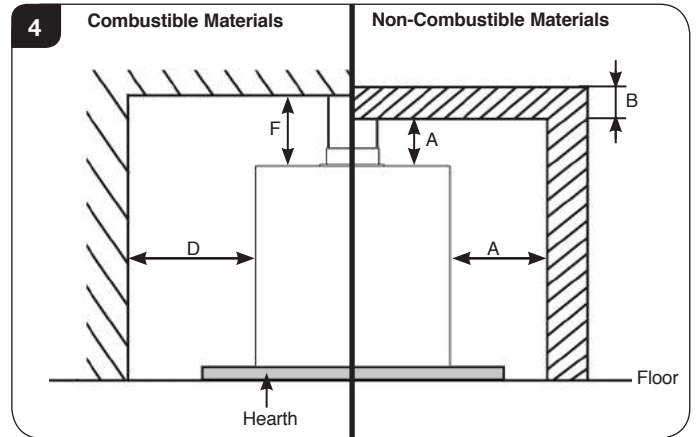

Fireplace: Minimum Clearances to the Rear

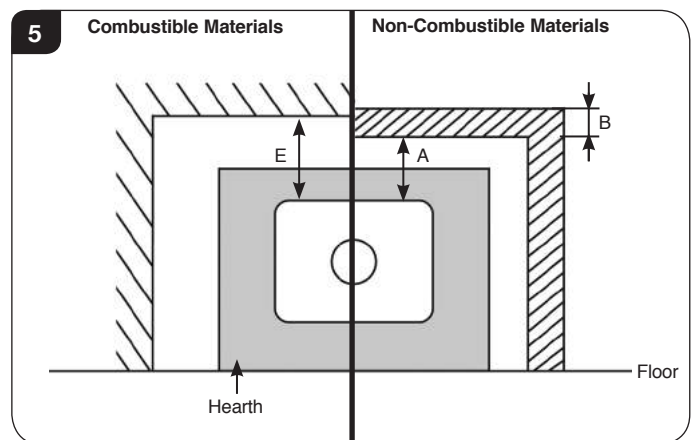

Installation Checklist

Non-Combustible Materials

- 4.2 All appliances will require some clearance between them and any non-combustible materials to allow for either:
- Installation, servicing or accessing controls.
 - Convection in order for the appliance to function properly.

Minimum clearances for installation/servicing/convection is:

Rear - 25mm	Sides - 50mm	Top - 100mm
-------------	--------------	-------------

NOTE: If the non-combustible surface is less than 200mm thick additional clearances may be required. This requirement ensures that the non-combustible material does not transmit excessive heat through the wall onto combustible material which might be placed against it.

See Diagrams 4 & 5 (Fireplaces) & Diagram 6 (Freestanding) and table below.

Distance to Non-combustible Materials		
Distance of Appliance to Wall (A)	Minimum Thickness of wall (B)	Minimum Height of Wall (C)
0mm - 50mm*	200mm	Height of appliance + 300mm OR 1200mm from the hearth (take largest dimension)
51mm - 300mm	75mm	
300mm+	No requirement	No requirement

Freestanding Installation

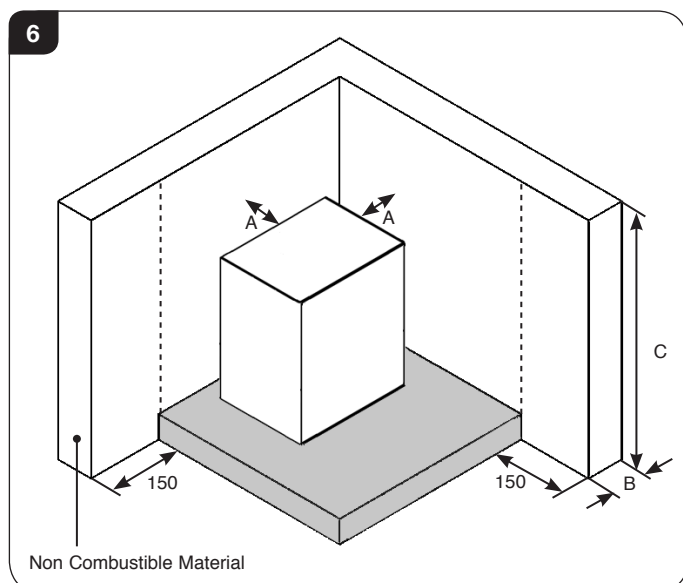

Combustible Materials

- 4.3 It is essential for safety to ensure the following clearances to combustible materials are maintained.

See Diagrams 4 & 5 and table below.

Model	A (side)	E (Rear)*	D (Above)
Studio 500	300	300	N/A
Studio 1	300	500	N/A
Studio 2	300	700	N/A
Studio 3	300	450	N/A

* Note this distance can be reduced by the fitting of a heat shield kit, check with your Stovax retailer for availability and clearances.

5. Smoke Control Kit

This section applies to the Studio products listed:

Product Code	Appliance
RVFST-500	Studio Freestanding 500
RVFST-1HT	Studio Freestanding 1
RVFST-2HT	Studio Freestanding 2

- 5.1 The Studio models listed are supplied with a pre-fitted smoke control kit and have been independently tested to PD6434 making them exempt from the controls that generally apply in Smoke Control Areas.
- 5.2 These models are suitable for use in a Smoke Control Area when burning wood and following the instructions for use specified in this manual but ONLY if the Smoke Kit has not been removed.
- 5.3 If fitted, the Smoke Control kit can be seen in the following locations, see Diagrams 7 & 8.

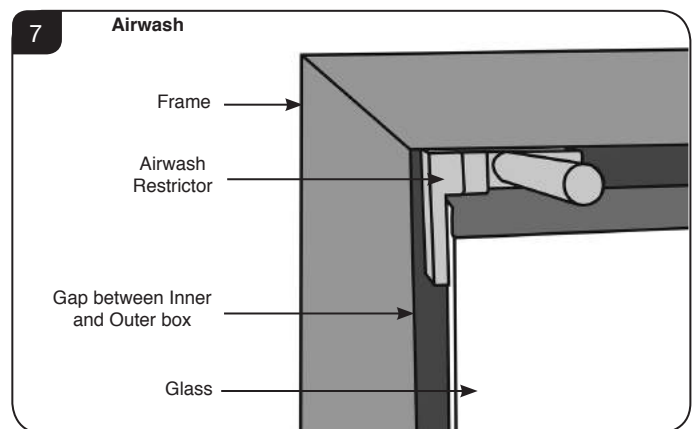

Installation Checklist

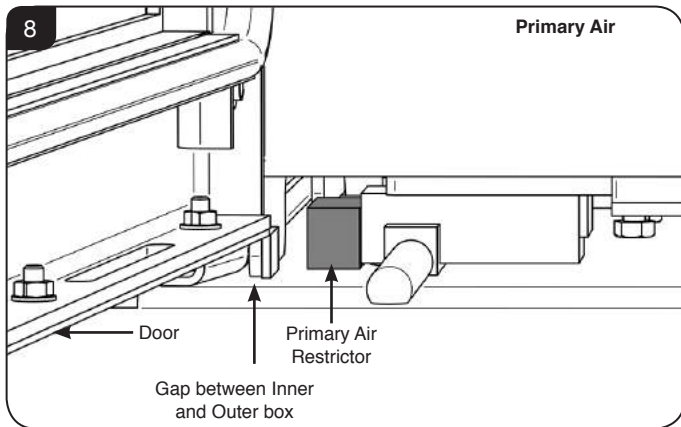

- 5.4 To meet the requirements of a Smoke Control Area the appliance **MUST** be operated correctly in order to minimise the amount of smoke produced.

i If these Studio models are installed outside of a Smoke Control Area then the Smoke Control kit can be removed to give more control over the lower burn rates. Removing the kit should only be done by a suitably qualified installer and must be done at the time of installation.

These instructions must be left with the User.

6. Optional Extras

Decorative Flue Cover

- 6.1 This appliance can be fitted with an optional decorative flue cover. For installation procedures please refer to the instructions supplied with the kit - Stovax part no. PM504.

Outside Air Kit

- 6.2 This appliance can be fitted with an optional kit to help bring air directly into the appliance from outside. The For installation and operating procedures you must refer to the instructions supplied with the Outside Air kit.

Bench

- 6.3 This appliance can be fitted with a bench, various sizes are available. This must be done at the time of installation. Please refer to instructions - PM205.

Heat Shield

- 6.4 This appliance can be fitted with a heat shield in order to decrease the distance the appliance can be installed from a wall. This must be done at the time of installation. Please refer to instructions - PM732.

Glass Top Plate

- 6.5 This appliance can be fitted with a decorative glass top plate. This must be done at the time of installation. See installation instructions, Section 6.

Pre-Installation Instructions

1. General

- 1.1 To make the installation of the appliance easier it is best to remove the internal components before fitting into the builders opening/studwork.
- 1.2 For the best results removing the following components as set out below.

2. Removal of the Door

Studio 500, 1 & 2

Before removing the door it is recommended to protect the left edge from damage using masking tape.

- 2.1 Open the door approximately 90°, see Diagram 1.

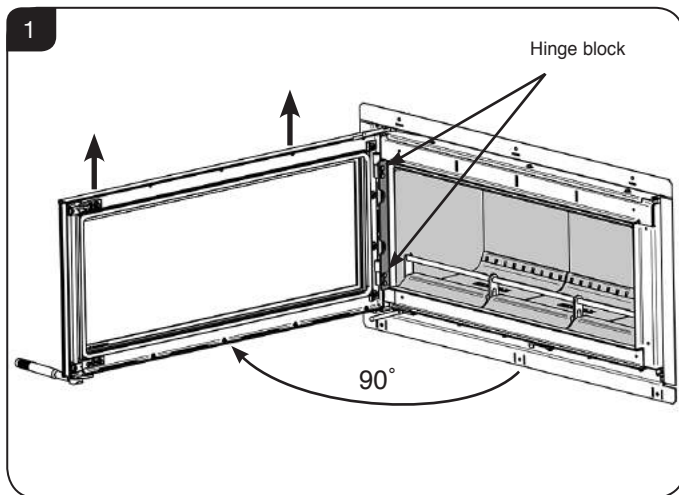

- 2.2 Move the Air Control to the far right, see Diagram 2.

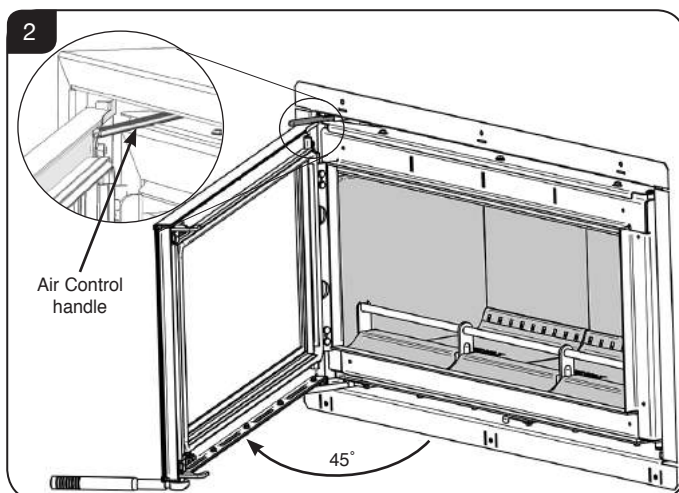

- 2.3 Lift the door vertically to remove from the hinge block, see Diagram 1.
- 2.4 Close the door 45°, ensuring the Air Control handle sits inside the channel in the top of the door (see Diagram 2) and carefully manoeuvre the door clear of the hinge mechanism.

- 2.5 Lie the door face down on a soft flat surface to protect the paint work and glass.

- 2.6 Reverse the procedure to re-fit the door.

Studio 3

This will require 2 people.

- 2.7 Open the door fully (see User Instructions, page 5).
- 2.8 Lock the hinges in position using a $\varnothing 3\text{mm}$ pin as shown in Diagram 3.

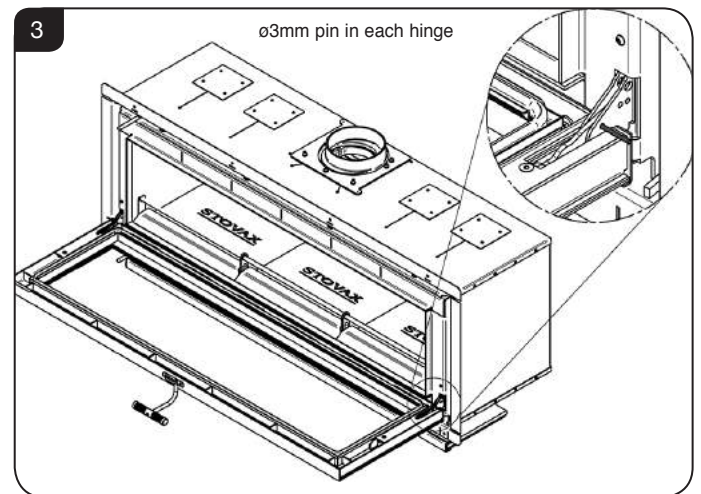

- 2.9 Raise the door vertically at the front.
- 2.10 Lower the door approximately 5mm and pull away from the appliance.
- 2.11 Lie the door face down on a soft flat surface to protect the paint work and glass.
- 2.12 Reverse the procedure to refit the door.

3. Removal of Internal Components

In the firebox of the Studio are several loose items including:

- A box containing:
 - Baffle Bricks
 - Firebricks
 - Bag containing Instruction Manual, Warranty & Door Tool, Log Guard End Supports
- Log Guard
- Front Baffle Support

- 3.1 Remove these carefully and put them safely to one side. They can be fitted after the appliance has been installed, see Installation Section.

Pre-Installation Instructions

4. Removal of the Top Baffles

The appliance is fitted with baffles in the top of the firebox to maintain efficient combustion.

Studio 500 and Studio 1 have 1 baffle.

Studio 2 has 2 baffles.

Studio 3 has 3 baffles.

- 4.1 Once the loose internal components have been removed it is possible to remove the metal Top Baffles.

Allow the appliance to cool fully before removing the baffle system.

Studio 500 & Studio 1

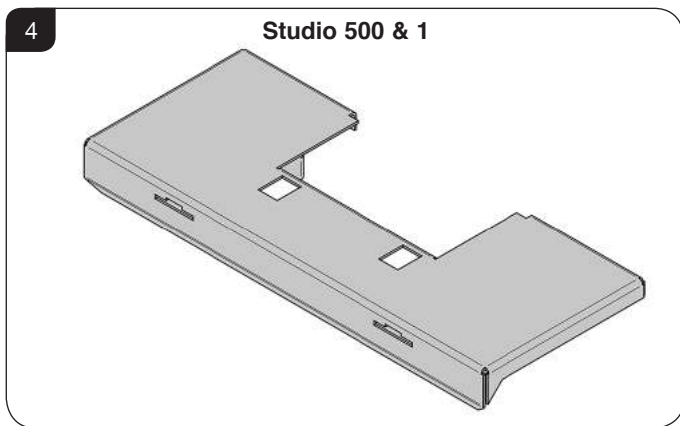

These models have a single section baffle.

Studio 2

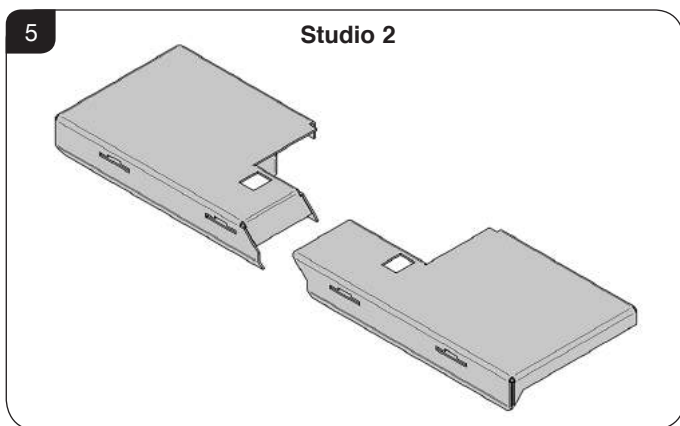

The Studio 2 baffle comes in two sections. To remove the baffle system first disengage the left hand side. The method of removal is the same for both sections.

Studio 3

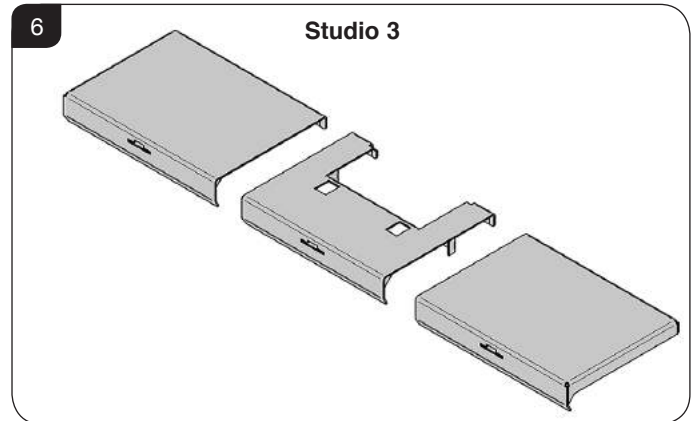

The Studio 3 baffle comes in three sections. To remove the baffle system the baffles must be taken out in the following order:

- Left hand side
 - Middle
 - Right Hand side
- The method of removal is the same for all sections.

All Models

- 4.2 Use two hands and lift the front edge of the baffle to clear the support tabs at the front of the firebox. Push the baffle towards the back of the appliance to free it from the tabs at the front, see Diagram 7.
- 4.3 Lower the baffle into the firebox to disengage from the support pins and carefully withdraw through the front of the appliance, see Diagram 7.
Take care not to damage the firebricks.

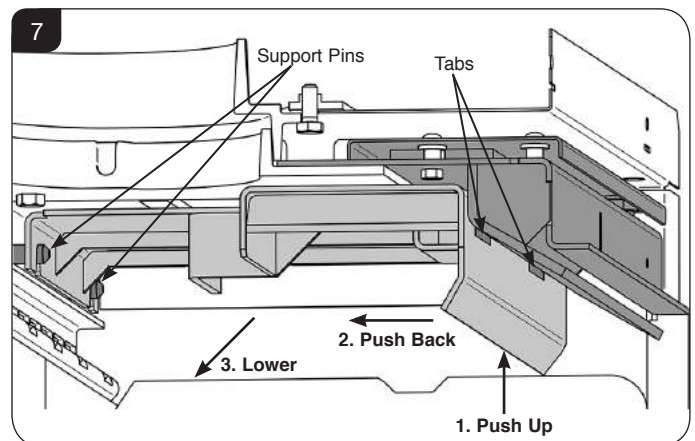

- 4.4 If the appliance has more than one baffle remove in the correct order.
- 4.5 Replace in reverse order.
- 4.6 The baffle system is designed to give safe and efficient operation of the appliance. Replace damaged baffles immediately.
- 4.7 **Do not modify the baffle system.**
Do not operate with the baffle system removed.

Pre-Installation Instructions

5. Separate the Inner & Outer Box

To protect the delicate parts of the appliance the product has been designed so that the inner box can be removed from the outer box.

Keep the inner box in a safe place whilst the outer box is installed into the fabric of the house, the main flue connections made and the walls finished.

When all the heavy work is complete the inner box can be re-installed into the outer box and the final connection made.

- 5.1 The internal components, bricks, baffles and the door etc should be removed to make the installation process easier and prevent damage.
- 5.2 First remove the inner collar, see Diagram 8.

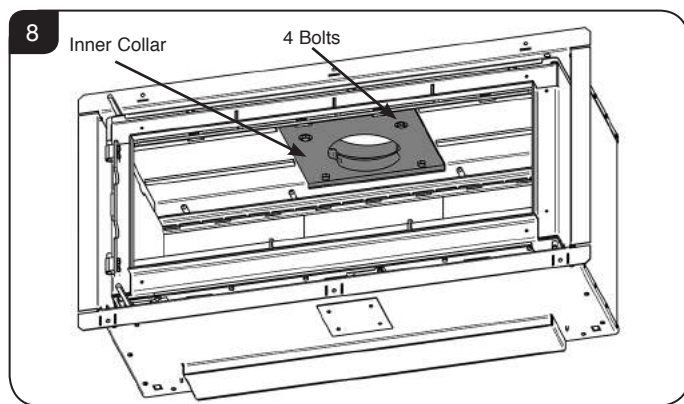

- 5.3 First remove the inner collar. Using a 13 A/F spanner, remove the 4 x bolts, see Diagram 9.

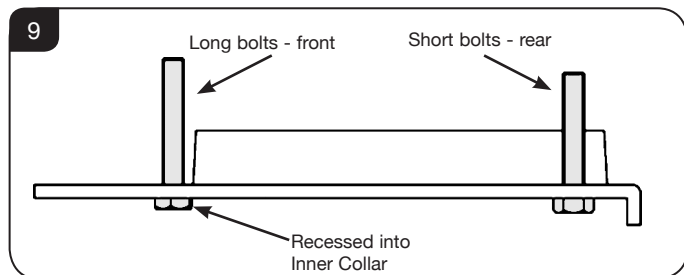

- 5.4 The inner box can now be slid out of the outer box. **There is a roller assembly at the rear which locates in cutouts on the outer box, see Diagram 10.**

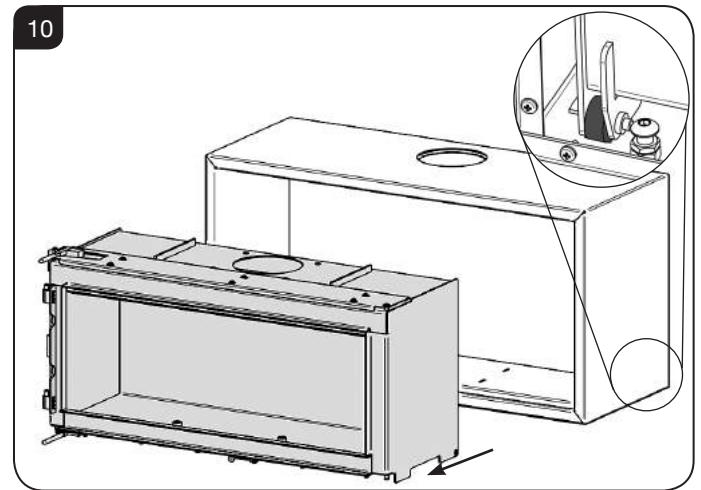

Pull the inner box carefully forward to release from the cutouts. It should now slide smoothly out of the outer box. This will require at least two people.

Installation Instructions

1. Installing the Appliance

Each installation is unique to the property so it is not possible to give details to suit every setting. The installation must comply with Building Regulations† and be made using "best practice" construction methods‡.

The clearance to combustible materials for the Stovax Studio models is greatly different due to the higher temperatures that the appliance can reach. Extra care must be taken when creating a builders opening. Pay careful attention to the distance to combustible materials recommended and ensure the housing for the appliance is built from non-combustible material.

Many fireplace openings have a supporting lintel. Do not remove without supporting the remaining structure of the building. **Do not support the structure with the appliance or the flue system.**

- 1.1 **Take care when installing the appliance. Careless handling and use of tools can damage the finish and/or area.**

i **NOTE: If installing with an Outside Air Kit, and/or a Heat Shield, please consult manuals PM732 and PM361 prior to installation.**

2. Bolting the Appliance to the Hearth

- 2.1 The appliance must be fixed to the hearth. Use the 4 hearth mount holes shown in Diagram 1.

Take care not to damage the hearth.

- 2.2 Position the appliance where required on the hearth and mark the location of the 4 fixing holes in the outer box.
- 2.3 Drill the right sized holes into the hearth.
- 2.4 Use suitable fasteners to fix into place.

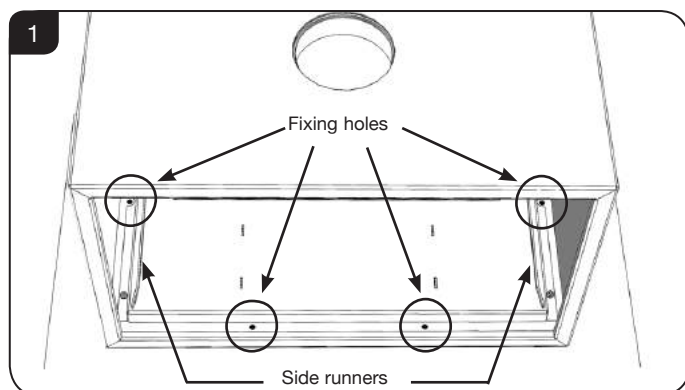

i † England and Wales – Document J / Scotland - Part F/Document J (Republic of Ireland only)
‡ the latest edition of BS 8303, BS EN 15287, BS 7566

Inserting the inner box:

- 2.5 Slide the inner box into the outer box. There is a roller assembly at the rear of the inner box which locates in cutouts in the base of the outer box, see Diagram 2.

This will require 2 people.

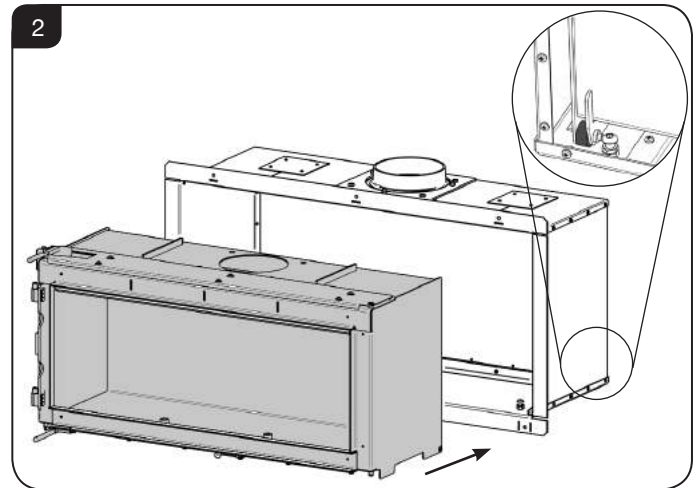

3. Top Flue Installation

- 3.1 Apply fire cement in to the faces shown prior to fitting the inner collar, see Diagram 3.

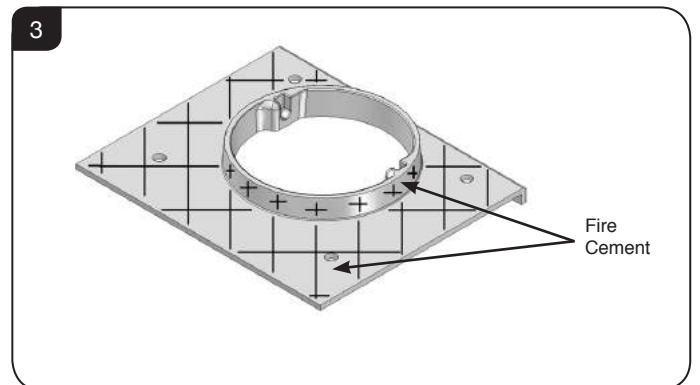

- 3.2 Fit the inner flue collar using the 4 bolts ensuring the 2 longer bolts are at the front and recessed into the Flue Collar, see Diagram 4. All bolts must be finger tight only at this stage.

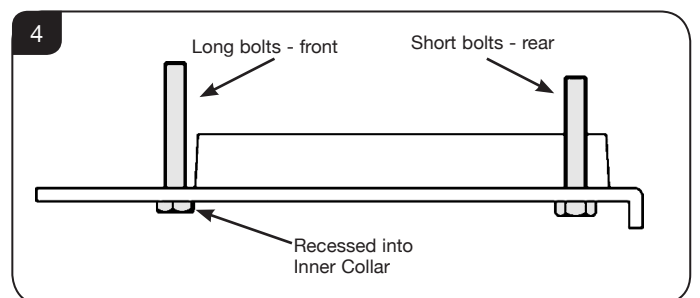

Installation Instructions

- 3.3 Check that the front of the inner box is parallel to the outer box and that the flue hole is lined up concentrically with the top flue collar and outer box hole. Adjust the position until correct and then fully tighten the 4 x bolts on the inner collar. **DO NOT OVER TIGHTEN THE BOLTS.**

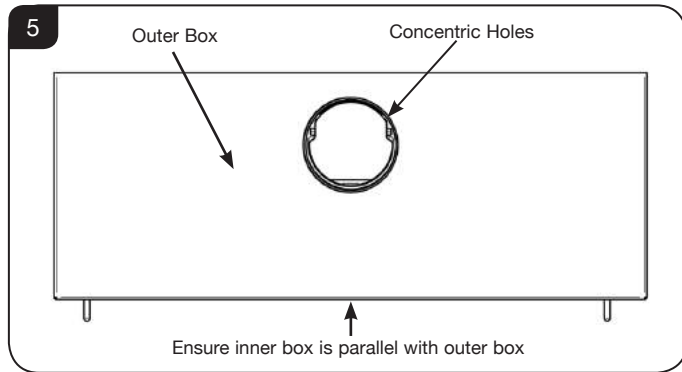

- 3.4 Replace the internal components (baffles, bricks, door etc), see relevant Pre-Installation sections.

To fit the pipe to the collar:

- 3.5 If not already fixed to the hearth, move appliance into position, taking care not to damage the hearth finish.
3.6 Connect appliance to chimney using flue pipe.
3.7 Seal the connecting joints.

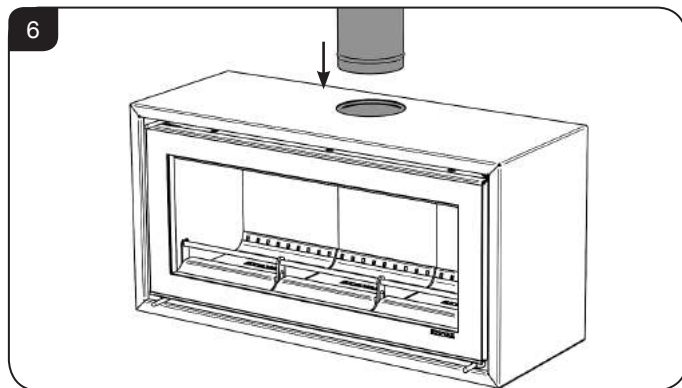

- 3.8 The flue must be installed in accordance with the manufacturers instructions.

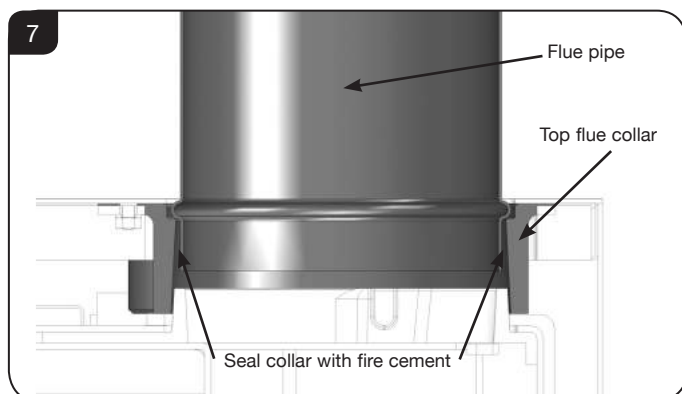

- 3.9 From the top of the stove, place a generous amount of fire cement inside the top flue collar.
3.10 Insert the 612mm long flue pipe into the flue collar so that the bulge is inside the flue collar and resting on the ledge.

NOTE: If a decorative flue ring is being fitted (RVAC220B) this must be done before final connection of the flue pipe.

- 3.11 **A Typical Top Flue Pipe Installation:**

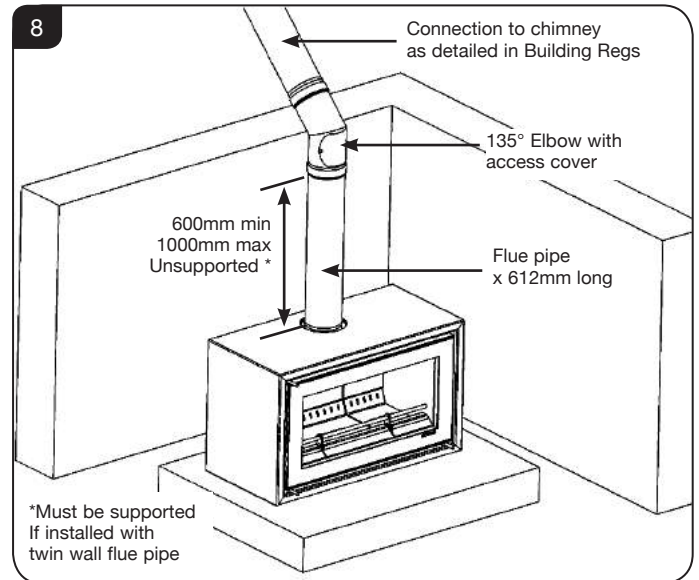

NOTE: If this appliance is NOT being fitted in a Smoke Control Area then the two parts that restrict the range of the air control sliders can be detached.

If the customer wants the ability to shut down the appliance completely, the air control sliders **MUST** be removed now as they cannot be accessed after installing the inner box. See Section 5 on how to remove the restrictors.

DO NOT REMOVE THESE RESTRICTORS IF FITTING THE APPLIANCE IN A SMOKE CONTROL AREA.

To finish this installation re-install the inner box.

Installation Instructions

4. Fitting of Internal Components

Once the inner box has been installed the internal components can be fitted.

4.1 The firebricks must be fitted before the baffle components.

Firebricks

4.2 The Firebricks and Lower Baffle bricks are supplied in a box for safe transportation. It is advisable to carefully remove all of the bricks from the container in order to correctly identify the various types.

4.3 The side bricks have part of the Log bar supports attached. These must be fitted and removed at the same time as the bricks.

4.4 Install in the following order, see Diagram 9.
Take care when handling and do not force into position.

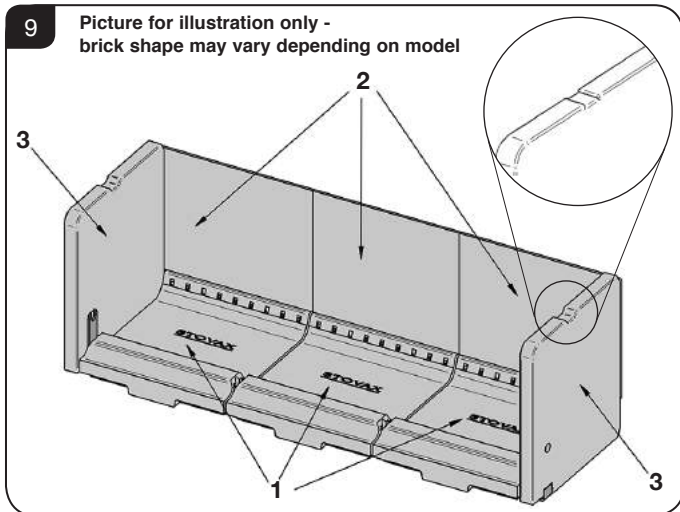

4.5 To do this:

All Models

- Place the base bricks in the firebox (1). Fit the left and right hand base bricks, then the middle.
- Place the back bricks in position on top of the base bricks (2).
- Fit the side bricks (3) with the Log Guard Supports in place. The Log Bar Support holes can be used as a finger hold - follow the method for the relevant model.

Studio 500 & 1

Tilt the brick at an angle and feed the top edge up and into the gap at the top of the firebox.

Straighten the brick in this position and lower into the gap between the side of the inner box and the base brick ensuring the Log Bar Support remains in place, see Diagram 10 and 11.

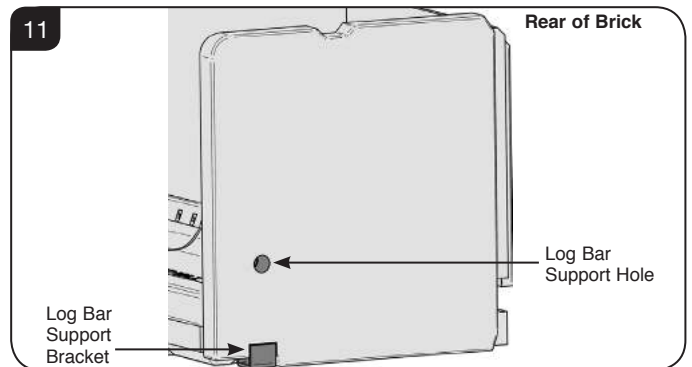
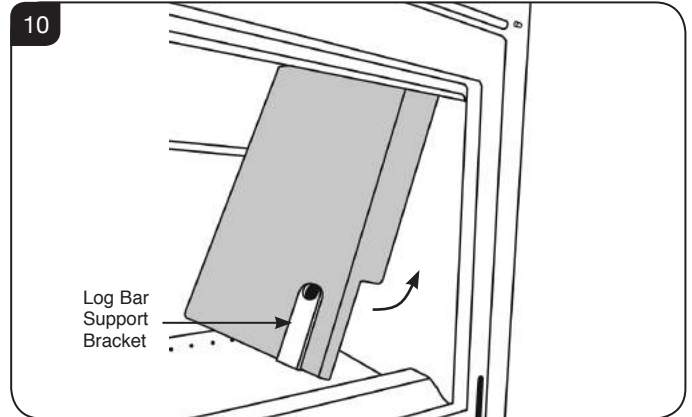

Studio 2 & 3

Tilt the brick at an angle and feed the lower edge down into the gap between the base brick and the side of the inner box.

Straighten the brick in this position and drop into place ensuring the Log Bar Support remains in place, see Diagram 11 and 12.

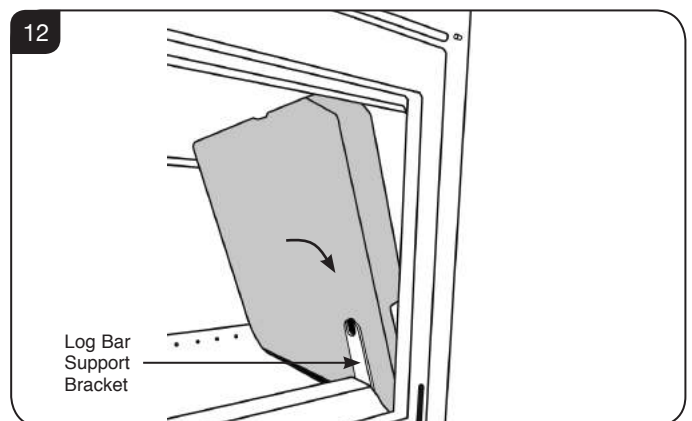

4.6 Repeat for the other side.

Installation Instructions

- 4.7 Removal is the reverse of this procedure. Allow the appliance to cool fully before removing baffle system.

Do not modify firebricks.
Do not operate with firebricks removed.

Upper Metal Baffle

The appliance is fitted with baffles in the top of the firebox to maintain efficient combustion.

Studio 500 and Studio 1 have 1 baffle.

Studio 2 has 2 baffles.

Studio 3 has 3 baffles.

- 4.8 Once the firebricks have been fitted it is possible to install the metal Top Baffles.

Studio 500 & Studio 1

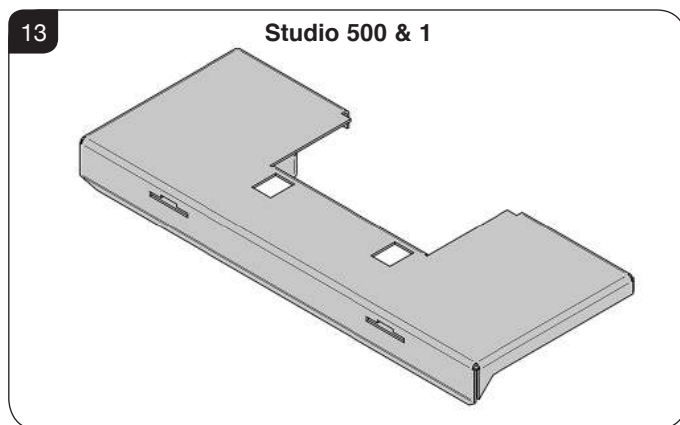

These models have a single section baffle.

Studio 2

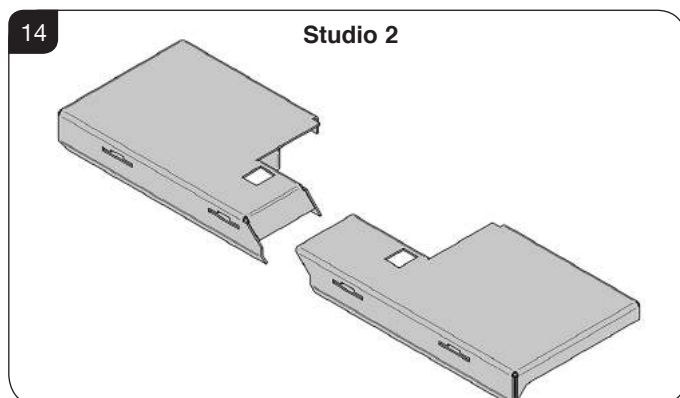

The Studio 2 baffle comes in two sections. Fit the right hand side baffle first. The method is the same for both sections.

Studio 3

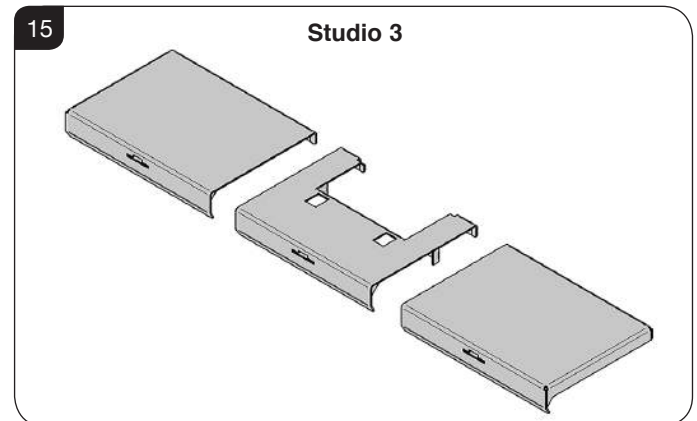

The Studio 3 baffle comes in three sections. To fit the baffle system the baffles must be placed in the firebox in the following order:

- Right Hand side
- Middle
- Left hand side

The method of fitting is the same for all sections.

All Models

- 4.9 Use two hands and place the rear edge of the baffle over the support pins at the back of the firebox. Raise the front so it is level and pull the baffle forwards to the front of the appliance and locate the keyslots in the front lip over the tabs at the top of the inner box, see Diagram 16.

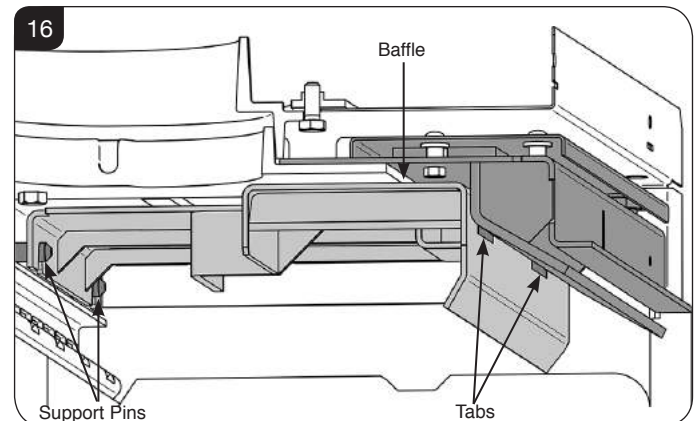

- 4.10 The baffle system is designed to give safe and efficient operation of the stove. Replace damaged baffles immediately.
- 4.11 **Do not modify the baffle system.**
Do not operate with the baffle system removed.

Installation Instructions

Lower Baffle bricks

The appliance is fitted with baffles in the top of the firebox to maintain efficient combustion.

- 4.12 To fit the Lower Baffle Bricks feed the Front Baffle Support bar into the appliance and rest on top of the side bricks.

This is best done by feeding one end of the bar towards the back of the firebox at an angle and then inserting the other end.

- 4.13 Once the support bar is inside the firebox bring forward as far as possible and place on the side bricks with the solid edge facing forward.

- 4.14 Insert the baffle bricks (see table) ensuring they are in the correct orientation, see Diagram 17.

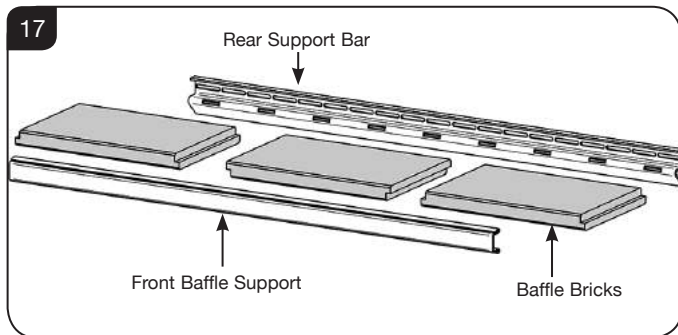

Model	Baffle Number
Studio 500	2
Studio 1	3
Studio 2	3
Studio 3	4

- 4.15 To do this:

- Rest the rear edge of the bricks on the support bar at the back of the firebox.
- Fit the two side bricks first, then insert the middle brick and support.
- Fit the Front Baffle Support over the front edge of the baffle bricks to hold in place.
- The Front Baffle Support bar should rest in the notch on the top of the firebricks.

Do not modify baffle bricks.
Do not operate with baffle bricks removed.

Log Guard

- 4.16 Ensure that the side supports have been fitted at the same time as the side Firebricks.

To fit the Log guard:

- Insert the Log Guard through the front of the appliance at an angle and rotate.

- With one end raised place the other end into one of the holes in the side bricks.

- Lower the Log Guard and insert the supports into the gaps between the base bricks and into the retaining brackets, see Diagram 18.

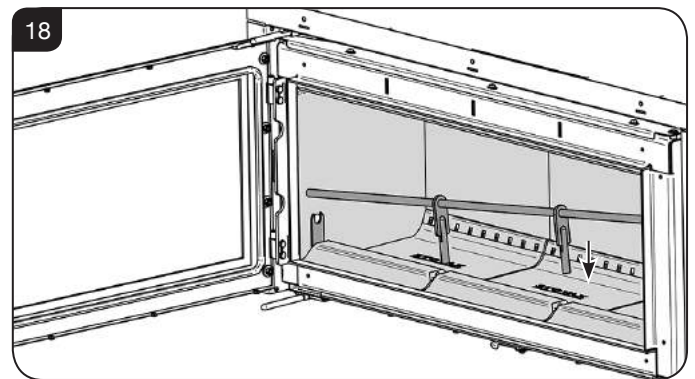

- Slide the Log Guard across so both end locate evenly in the holes in the side bricks, see Diagram 19.

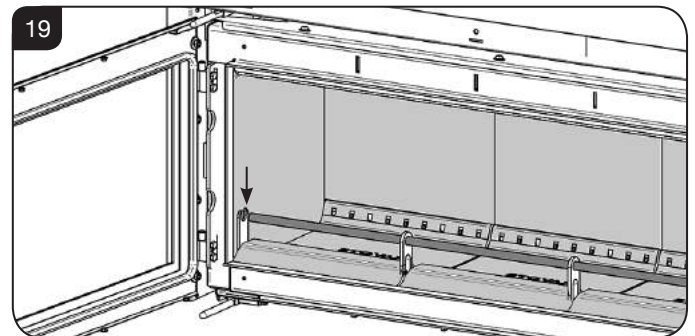

Do not use appliance without the log guard in position.

Installation Instructions

5. Smoke Control Kit

This section applies to the Studio products listed:

Product Code	Appliance
RVFST-500	Studio Freestanding 500
RVFST-1HT	Studio Freestanding 1
RVFST-2HT	Studio Freestanding 2

- 5.1 The Studio models listed are supplied with a pre-fitted smoke control kit and have been independently tested to PD6434 making them exempt from the controls that generally apply in Smoke Control Areas.
- 5.2 These models are suitable for use in a Smoke Control Area when burning wood and following the instructions for use specified in this manual but **ONLY** if the Smoke Kit has not been removed.

i If these Studio models are installed outside of a Smoke Control Area then the Smoke Control kit can be removed to give more control over the lower burn rates. Removing the kit should only be done by a suitably qualified installer and must be done at the time of installation.

The kit consists of two restricting brackets that are fitted to each of the air controls.

- 5.3 To remove the Smoke Control kit first ensure the appliance is completely cool.
- 5.4 Carefully follow the instructions to remove the inner box and place on a soft flat surface it will now be possible to access the brackets.

Airwash Restrictor

- 5.5 The Airwash restrictor bracket is a stop that fits on the top left hand side of the inner box, see Diagram 20.

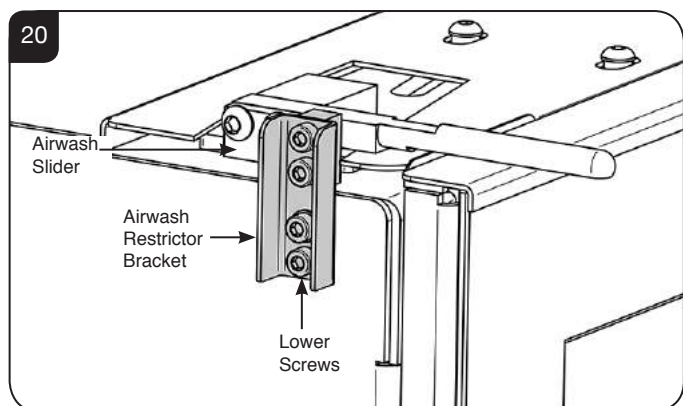

- 5.6 Remove the 2 lower screws that secure the bracket to the inner box. The bracket can now be stored safely in case it is required.
- 5.7 Replace the 2 screws in the holes that are in the side of the inner box to seal off unwanted air flow.

Primary Air Restrictor

- 5.8 Gently tip the inner box onto its back. It is now possible to access the Primary Air Bracket.
- 5.9 The Primary Air Restrictor is secured by two screws, see Diagram 21.

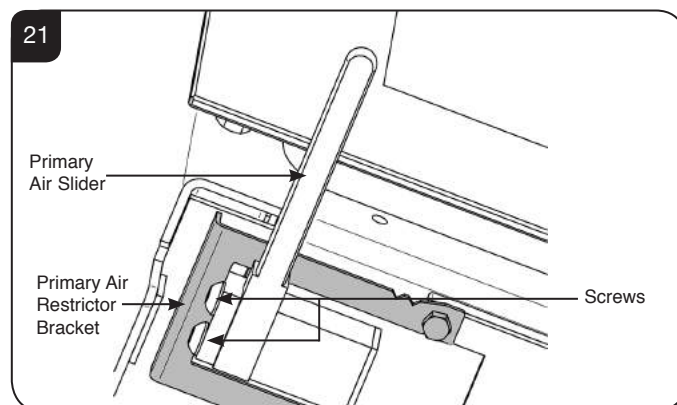

- 5.10 Undo the screws by 3-4mm, but do not remove fully or the handle will fall off.
- 5.11 Slide the bracket from under the screws and store carefully in case it is required.
- 5.12 Tighten the 2 screws fully back into the side of the Primary Air Slider.

6. Glass Top Plates

This appliance can be fitted with optional glass top plates.

Product Code	Left Side	Right Side
RVFS-500BG	RVFS-MEC9298	RVFS-MEC9299
RVFS-1GB	RVFS-MEC8816	RVFS-MEC8815
RVFS-2GB	RVFS-MEC8808	RVFS-MEC8807
RVFS-3GB	RVFS-MEC9364	RVFS-MEC9365

- 6.1 The glass top plates have 4 x 6mm silicon feet on the underside to space them off the top of the appliance.

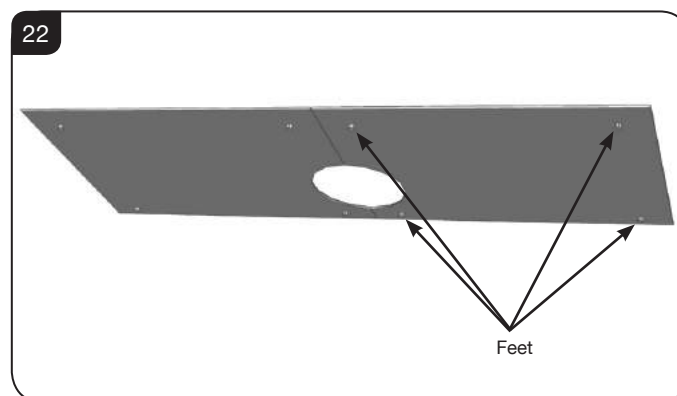

Installation Instructions

6.2 Place the glass plates feet down on top of the appliance.

Ensure the glass tops are flush with the front and sides of the appliance and placed correctly around the flue pipe.

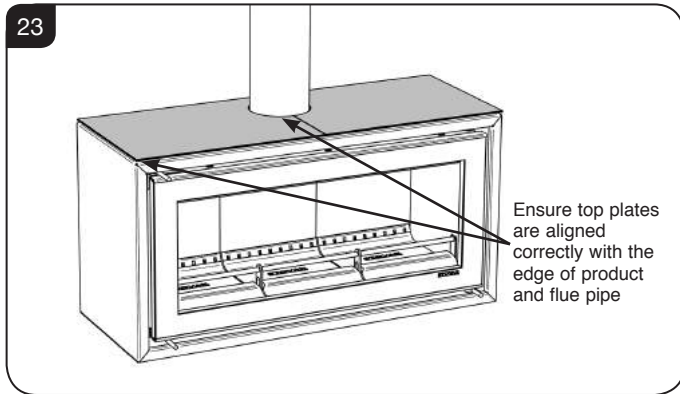

7. Optional Decorative Flue Cover

This appliance can be supplied with an optional decorative flue cover. Please refer to the instructions supplied with the flue cover for installation guidance (PM504).

8. Optional Bench Plinths

This appliance can be installed on an optional bench, available in two heights and a variety of widths. Please refer to the instructions supplied with the bench for installation guidance (PM205). **If installing a bench the appliance must be secured to the bench and the bench must be fixed to the hearth.**

9. CO Alarms

All open flued appliances can be affected by temporary atmospheric conditions which may allow fumes to enter the house. **Building regulations require that whenever a new or replacement fixed solid fuel or wood/biomass appliance is installed in a dwelling a carbon monoxide alarm must be fitted in the same room as the appliance. Further guidance on the installation of the carbon monoxide alarm is available in the latest edition of BS EN50292 and from the alarm manufacturer's instructions.**

HETAS recommend the unit is permanently fixed in accordance with the manufacturer's installation instructions or with the guidance contained in Approved Document J where no other information is available.

Provision of an alarm must not be considered a substitute for either installing the appliance correctly or ensuring regular servicing and maintenance of the appliance and chimney system.

Commissioning

Commissioning

1.1 To commission:

- Replace the internal components.
- Check the door alignment and catch operation and adjust if required (see *Maintenance & Servicing, Sections 4 & 5*).
- Check the soundness of door seals, castings and joints.
- Check the operation of the air controls.

1.2 Now carry out a final smoke draw test:

- Warm the flue with a blowlamp, or similar, for about 10 minutes.
- Place a smoke pellet on the centre of the grate, with the air controls open.
- Close the door. Smoke should now be drawn up the flue and be seen to exit from the flue terminal.
- Complete test with all doors and windows closed in the room where the appliance is fitted.
- If there are any extractor fans in adjacent rooms the test must be repeated with the fans running on maximum and with interconnecting doors open.
- Check the effect of ceiling fans during the test.

If the test fails, re-check the suitability of the flue system and ventilation. An inadequate air supply to the room is potentially dangerous.

- Light the appliance and slowly increase the temperature.
- Ensure no combustion products enter the room.
- Open the main fire door when the appliance reaches operating temperature and carry out a spillage test with a smoke match or pellet around the door opening.

1.3 If excessive spillage occurs allow the appliance to cool and re-check the flue system and ventilation.

1.4 Finally:

- Explain to the user the correct operation of the appliance, use of the controls and the importance of only using suitable fuels in order to reduce smoke emissions - particularly if they live in a Smoke Control Area.
- Ensure that a CO alarm has been fitted and make the user aware of its operation and importance, referring them to the Warning section on page 5 of the User Instructions.

- Explain the cleaning and routine maintenance requirements.
- Explain the requirement to use a suitable fireguard when children, elderly or infirm persons are near the appliance.
- Record retailer/supplier and installer details in Appliance Commissioning Checklist (page 3, Instructions for Use).
- Record serial number in Appliance Commissioning Checklist (page 3, Instructions for Use).

This number is required when ordering spare parts and making warranty claims.

- Give this instruction manual to the customer.

Certificate Of Compliance

Upon completing the installation, the form below must be filled in by your installer to comply with the requirements of HETAS and the building regulations. The installer must give these details, including their HETAS registration number, for the purposes of any insurance details that may change as a result of the appliance being installed.

HETAS LTD - CERTIFICATE OF COMPLIANCE

PLEASE TICK APPROPRIATE BOXES OR ENTER DETAILS IN BOXES BELOW



Record ID (HETAS Use Only)	<input type="text"/>	(*indicates that this data must be given)
Customer Name	*	
Installation Address	*	
Installation Address		
Installation Address		
Installation Address		
Town	*	
Postcode	*	Work Completion Date *
Local Authority Name (*Must be given if no postcode available)		
Installing Company Name	*	Company's HETAS Reg. No. *
Installing Engineer's Name	*	Engineer's HETAS Reg. No. *

Description of Work

Location:
 Lounge Dining Room Kitchen Utility Room Bedroom Other, Specify

Appliance: Dry Open Fire Open Fire with Boiler Dry Cooker Cooker with Boiler
 Dry Roomheater/Stove Roomheater/Stove with Boiler Independent Boiler
 Make Model Heat Output kW

System: New Heating and Hot Water System Updated Existing Heating and Hot Water System Dry System Only

If Wet System: Is the Hot Water System Unvented? Y N

Chimney: New Insulated Factory Made Chimney System Installed

Relining of existing chimney: Twin Wall Flexible Liner (for Class 1 Appliance) Cast In-situ Liner
 Rigid Sectional Liner Metal Rigid Sectional Liner Other

Hearth: New Hearth/Surround fitted Existing Hearth Surround Updated

Additional Information

Connecting fluepipe: Diameter mm Socket joints upward and gas tight

Provision for sweeping chimney/fluepipe: Yes No Chimney Data Plate Location

Air supply: Has a permanently open air vent been fitted: Yes No
 Is vent opening at least 50% of cross sectional area of throat/flue or State total free area of air vent mm²

Confirm an approved Carbon Monoxide alarm has been fitted

Testing & Commissioning to Approved J Appendix E

Confirm you have commissioned and tested the appliance & associated work for safe and efficient operation

Declaration of completion As the competent person responsible for the work described above, I confirm that the appliance and associated work has been installed in accordance with the HETAS rules of registration, and that the work complies with Regulations 4 and 7 of the Building Regulations, and Approved Documents J, G & L as applicable.

Signed: _____ Print name: _____ Date: _____

COPIES OF THIS COMPLETED CERTIFICATE MUST BE (WHITE COPY) SENT TO HETAS LTD AT THE ADDRESS GIVEN BELOW (PINK COPY) GIVEN TO THE CUSTOMER FOR RETENTION (YELLOW COPY) RETAINED BY THE INSTALLING COMPANY

THIS CERTIFICATE SHOULD BE RETAINED BY THE PROPERTY OWNER WHO MAY BE REQUIRED TO PRODUCE IT IN ANY FUTURE SALE OF THE PROPERTY.

HETAS Ltd, Unit5, Newton Trading Estate, Green Lane, Tewkesbury, Glos. GL20 8HD HETAS Ltd © (Oct 2010)

Maintenance & Servicing

For a complete list of spare parts and accessories contact your Stovax or call 01392 474011

1. Annual Service

i **IMPORTANT: Stovax provide gauntlet style gloves for the users protection from heat and any sharp edges when using the appliance. For your safety ensure that gloves are always worn when opening, operating, refuelling or handling internal metalwork.**

- 1.1 Before the start of the heating season strip, inspect and clean the appliance as detailed:
- Allow appliance to cool.
 - Remove all internal parts: baffle, log guard and firebricks. Take care handling firebricks as they can become fragile after a period of use.
 - Sweep the appliance at this point if necessary.
 - Vacuum clean any remaining ash and debris from the inside of the appliance. Stovax offer a filter/collection attachment for vacuum cleaners to protect them from fire ash: Ash Clean (Stovax Part No. 2091).
 - Check the parts for any damage. Replace any damaged parts using genuine Stovax replacements parts.
 - Check and clean the firebricks with a soft brush. Some surface damage will occur during use. The life of the bricks will depend on the type of fuels burnt and the level of use. **Replace damaged bricks as soon as possible.**
 - Re-fit cleaned internal parts.
 - **On appliances with printed glass do not use cleaning agents that have a high alkaline or acidic content, for example Stovax Gel Cleaner, these are aggressive cleaning agents designed to be used with heavily stained clear glass. On printed glass surfaces, use Stovax Glass Cleaner (Stovax No.4103) which is better formulated for this application.**
- Do not use abrasive cleaners to remove tar or soot deposits from the glass.**
- Fit new door rope seal (see *Maintenance and Servicing, Section 3*).
 - Lightly oil the door catch mechanism and hinge pins. Avoid getting oil onto the door seals and glass.
 - To refresh painted finishes a touch up spray is available. Contact your Stovax retailer quoting the serial number found on the appliance data badge.

- 1.2 Use genuine Stovax replacement parts to keep the appliance in safe, efficient working order. This is a list of the maintenance products that may need be required:

Task	Product name
Preventing build-up of creosote in flue	Protector (15 sachets)
	Protector (1kg tub)
Sealing flue pipe joints	Fire Cement (500g tub)
	Fire Cement (600g cartridge)
Re-painting	Touch Up Paint (150ml aerosol)
Protecting your hands	Heat resistant leather gloves
Thermic seal glue	(50ml bottle)
Cleaning Glass	Stovax Glass Cleaner (No. 4103)
	Stovax Gel Cleaner
Ash Clean	Vacuum Cleaner Attachment
Door Maintenance (Studio 3 only)	Anti-Seize Grease

These products, available online at www.stovax.com or from your local Stovax dealer, along with regular maintenance and use of correct fuels, will keep the appliance in the best possible condition.

- 1.3 For more information about the Stovax Group products please visit our web site at www.stovax.com
- 1.4 Burn at a low temperature for the first day of use after any maintenance. This allows the seals, fixing glues and paint to fully cure.
- 1.5 During this time the appliance may give off some unpleasant odours. Keep the room well ventilated to avoid a build-up of fumes.
- 1.6 Your Stovax dealer can carry out service and maintenance.

2. Removal of Internal Parts

- 2.1 To service and maintain the good working condition of your appliance it will be necessary to remove several internal parts. Consult the section for the following:
- Door Assembly** - Pre-Installation Section 2, page 19.
 - Upper Baffles** - Pre-Installation Section 4, page 20.
 - Firebricks** - Maintenance & Servicing Section 6, page 34.
- 2.2 Reverse the method of installation to remove the **Lower Baffle Bricks, Firebricks** and the **Log Guard** see Installation Section 4.

Maintenance & Servicing

3. Fitting a new Door Seal - All Models

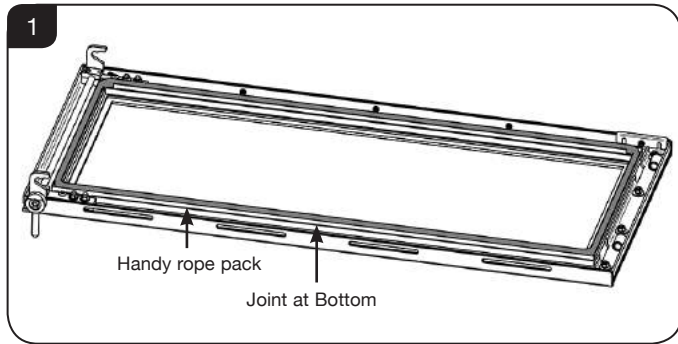

3.1 To maintain the safe use of your appliance you need to replace damaged or worn door sealing rope. To complete this operation remove the door see Section 2 in the Pre-Installation section.

3.2 Remove the old rope and scrape old glue from the locating groove. Clean the locating groove with a clean dry cloth to remove all old dust and debris.

3.3 Squeeze a generous bead of fresh Stovax Thermic Seal glue into the rope locating groove.

Press the new Stovax rope into the locating groove, placing the joint in the middle of the top edge of the door using tape supplied for the ends.

3.4 Refit the door and close the door to apply pressure to the new rope.

Leave the appliance closed for at least 12 hours before lighting the appliance and using at a low output for approximately one day.

3.5 Using the appliance with a damaged door seal can cause dangerous fumes to enter the room, or the appliance to over fire, resulting in damage.

4A. Adjusting Door Hinges - Studio 500, 1 & 2

4a.1 To maintain the safe use of your appliance, you may need to adjust the door hinges to ensure the safe, correct closing of the door. The door must be horizontal/level with the top of the inner box and the door catch engages correctly.

4a.2 Adjustment is possible in 2 places:
Door Hinge Assembly
Hinge Blocks on Inner Box

4a.3 Open the door to give access to these 2 positions.

Door Hinge Assembly

4a.4 Use a 10mm socket to slightly loosen the fixing nuts on the Door Hinge Assembly, see Diagram 2.

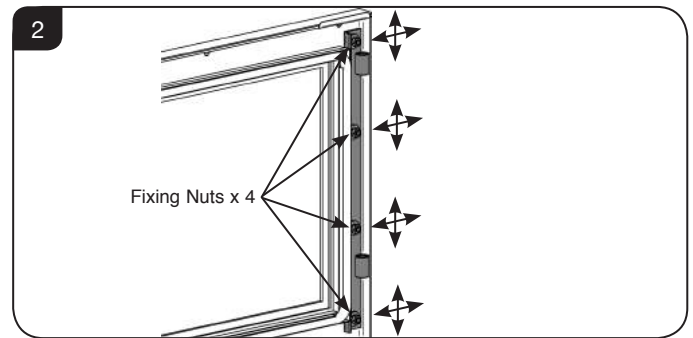

4a.5 Loosening the Door Hinge Assembly allows for fine vertical and horizontal adjustment of the door position. This may require a trial and error approach to find the correct position. Ensure the door is horizontal before tightening the fixing nuts.

Hinge Blocks on Inner Box

4a.6 Using a 10mm A/F spanner slightly loosen the fixing nuts inside the stove as shown in Diagram 3. This will give vertical and horizontal adjustment which may need a trial and error approach to find the correct position. The door must be horizontally level.

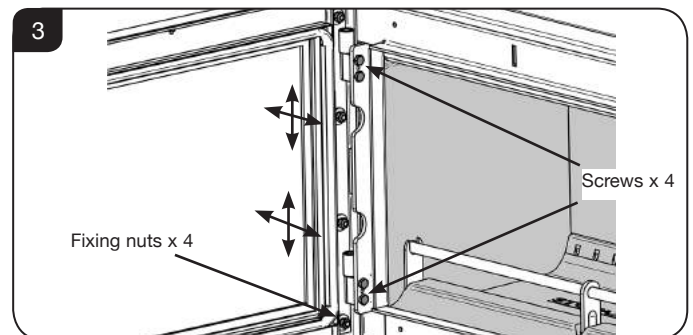

Maintenance & Servicing

4B. Lubricating Door Hinges - Studio 3 only

- 4b.1 If the operation of the door becomes stiff or fails to close properly it may be necessary to apply grease to the door hinge.
- 4b.2 Complete lubrication of the hinges as follows:
- Open the door fully.
 - Use a small paint brush to add a small amount of high temperature anti-seize grease (Stovax part number - RVS-MEC10275) to points 'A' and 'B', see Diagram 4.

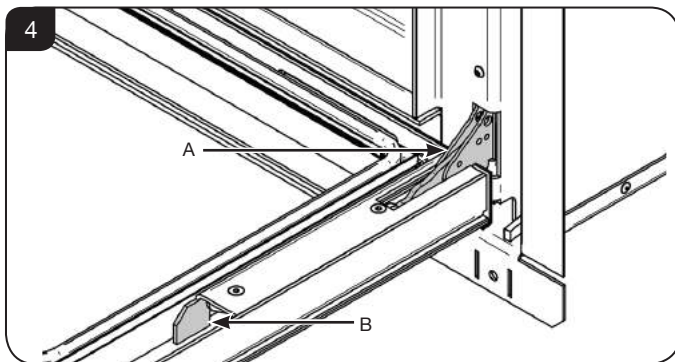

- 4b.3 Open and close the door a few times to work the grease into the hinge to return it to smooth operation.

5A. Adjusting the Door Catch - Studio 500, 1 & 2

- 5a.1 To maintain the safe use of your appliance you may need to adjust the door catch to ensure the safe, correct closing of the door. If the door hinges have been adjusted the door catch may need adjustment.
- 5a.2 The catches are located at the top and the bottom of the right side of the door.

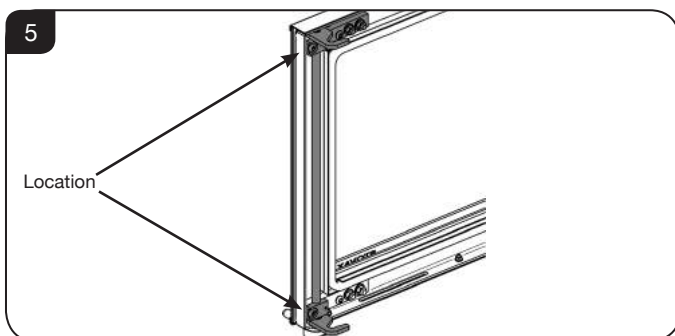

- 5a.3 The top and bottom catches will need to be adjusted separately and in the same manner. The catch block can move in two directions, see Diagram 6, 7 & 8.

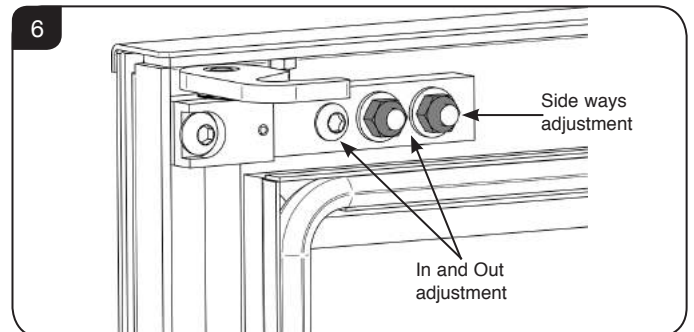

Sideways Adjustment

Using a 10mm A/F Spanner loosen the 2 nuts that hold the catch block to the door.

Do not remove the nuts completely.

This will allow some movement left or right to suit.

Tighten the nuts and recheck the catch operation.

In and Out Adjustment

Loosening or tightening the M6 screw and the nuts on the catch block will cause the catch to move in or out from the door and allow the hook to gain better purchase on the door rollers.

Do not remove screw or nuts completely.

- 5a.4 **To move Door Catch in:**

Loosen Nuts 1 & 2.

Wind screw **IN** until the Door Catch is in desired position.

Tighten Nuts 1 & 2 down to Catch Block.

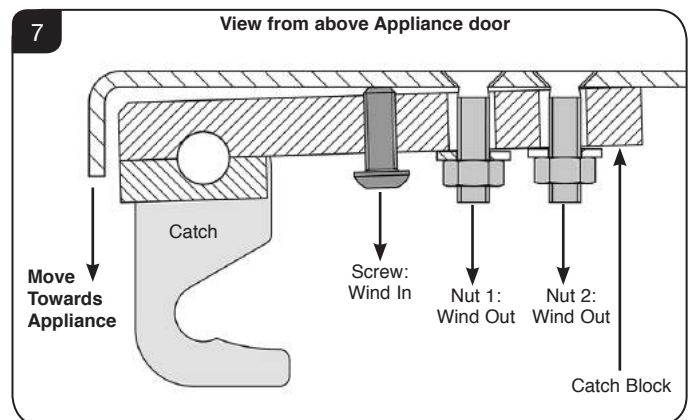

Maintenance & Servicing

5a.5 To move Door Catch out:

Loosen Nuts 1 & 2.
Wind screw **OUT** until the Door Catch is in desired position.
Tighten Nuts 1 & 2 down to Catch Block.

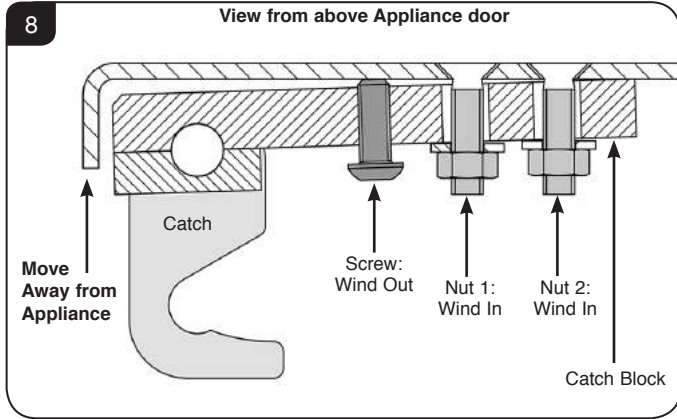

Do a Paper Test

To do a paper test shut a piece of paper in the door at the edges to test how well the rope seal stops the air from entering the appliance. If the paper can be pulled out easily then the seal is not sufficient and the rope must be replaced. Repeat this around all the edges of the appliance.

5B. Adjusting the Door Catch - Studio 3

5b.1 There is no user adjustment of the door.

6. Removal of the Firebricks

Depending on the model purchased it may be necessary to remove additional parts of the appliance when servicing to access the firebricks.

Studio 500 & 1

It is possible to remove the firebricks with the Upper Metal Baffle in place.

Remove the following:

Log Guard

- Slide the Log Guard to one side to disengage from the hole in the side brick.
- Raise the free end and remove from the gaps in the base bricks.
- Withdraw from the hole in the other side brick and rotate the Log Guard through the front of the appliance.

Baffle Bricks

Pull the Front Baffle Support off the baffle bricks and move as far forward as possible.
Carefully remove the bricks working from the centre outwards.

Angle the Front Baffle Support to free from the firebox.

It is now possible to remove the Firebricks.
Lift the side bricks using the Log Guard support slots as finger holds and clear the base bricks; angle the bottom of the side brick towards centre of the firebox and withdraw.

Remove the back bricks, then the base bricks.

Studio 2 & 3

It is necessary to remove the Baffle Bricks and the side Upper Metal Baffles before attempting to remove the firebricks to avoid damage, see *Pre-Installation Section*.

Lift the side bricks slightly using the Log Guard support slots as finger holds; tilt the top of the side brick towards centre of the firebox and continue lifting to withdraw.

Remove the back bricks, then the base bricks.

Technical Appendix

Legal Requirements

Before installation and/or use of this appliance please read these instructions carefully to ensure that all requirements are fully understood.

The appliance must be fitted by a registered installer*, or approved by your local building control officer.

It is very important to understand the requirements of the national Building Regulations† and standards‡, along with any local regulations and working practices that may apply. Should any conflict occur between these instructions and these regulations then the regulations must apply.

Your local Building Control Office can advise regarding the requirements of the regulations.

i † England and Wales – Document J / Scotland - Part F/Document J (Republic of Ireland only)
‡ the latest edition of BS 8303, BS EN 15287, BS 7566
*Registered on the Competent Persons Scheme (GB only) see page 38 / INFO (Republic of Ireland).
**Health and Safety at Work Act 1974

Works must be carried out with care to meet the requirements of Health and Safety† and comply with the Health and Safety rules**, and any new regulations introduced during the lifetime of these instructions. Particular attention should be drawn to:

- **Handling:** The appliance is heavy. Adequate facilities must be available for loading, unloading and on site handling.
- **Fire Cement:** Some fire cement is caustic and must not come into contact with the skin. Protective gloves must be worn. Wash hands thoroughly with plenty of water after contact with skin.
- **Asbestos:** This appliance contains no asbestos. If there is the possibility of disturbing any asbestos in the course of installation seek specialist guidance and use appropriate equipment.
- **Metal Parts:** Take care when installing or servicing the stove to avoid personal injury.

A faulty installation can cause danger to the inhabitants and structure of the building.

For users of this appliance:

Your building insurance company may require you to inform them that a new heating appliance has been installed on your property. Check that your cover is still valid after installing the appliance.

1. Flue Outlet Positions

These positions are defined by Document J of the Building Regulations.

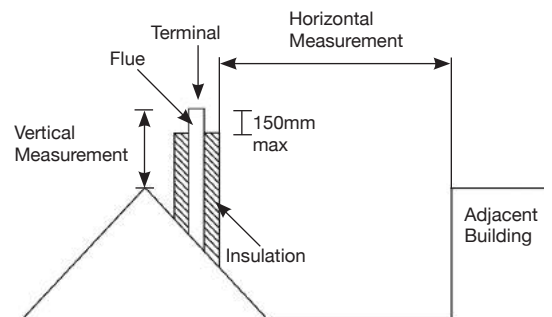
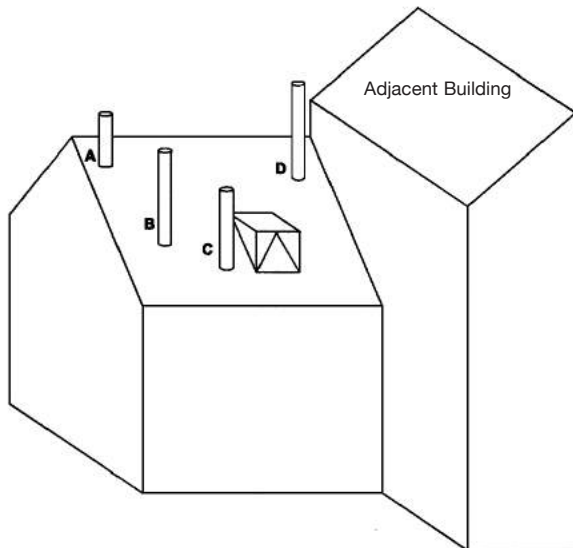

The datum for vertical measurement is the point of discharge of the flue from either the point of discharge of the flue or 150mm above insulation, whichever is the lower.

IMPORTANT: Seek specialist advice if installing in a dwelling with a thatched roof

Point where the flue passes through weather surface (Notes 1 & 2)		Clearances to flue outlet
A	At or within 600mm of the ridge	At least 600mm above ridge
B	Elsewhere on roof (whether pitched or flat)	At least 2300mm horizontally from the nearest point on the weather surface and: a) at least 1000mm above highest point of intersection of the chimney with and the weather surface; or b) at least as high as the ridge
C	Below (on a pitched roof) or within 2300mm horizontally to openable rooflight, dormer window, or other opening (Note 3)	At least 1000mm above the top of opening
D	Within 2300mm of an adjoining or adjacent building, whether or not beyond the boundary (Note 3)	At least 600mm above any part of the adjacent of building within 2300mm

1) The weather surface is the building external surface, such as it's roof tiles or external walls.
2) A flat roof has a pitch less than 10°.
3) The clearance given for A or B, as appropriate, will also apply.
4) A vertical flue fixed to an outside wall should be treated as equivalent to an inside flue emerging at the nearest edge of the roof.

Technical Appendix - Flues

2. Flue or Chimney

- 2.1 The flue or chimney system must be in good condition. It must be inspected by a competent person and passed for use with the appliance before installation.

Products of combustion entering the room can cause serious health risks.

- 2.2 The following must be checked:

— The construction of the masonry chimneys, flue block chimneys and connecting flue pipe system must meet the requirements of the Building Regulations†.

— A flexible flue liner system can be used if certified for use with solid fuel systems and installation complies with manufacturer's instructions and Building Regulations. The flue liner must be replaced when an appliance is replaced, unless proven to be recently installed and in good condition.

— If it is necessary to fit a register plate it must conform to the Building Regulations†.

— The minimum height of the flue or chimney must be 4.5m from the hearth to the top of the flue, with no horizontal sections and a maximum of 4 bends. Bends must have angles of less than 45 degrees from the vertical.

— There should be at least 600mm of vertical flue pipe above the appliance before any bends are introduced.

— Ensure the connecting flue pipe is kept a suitable distance from any combustible material and does not form part of the supporting structure of the building.

— The installer must ensure the flue pipe diameter is not less than the diameter of the outlet of the appliance and does not narrow to less than the size of the outlet at any point in the system.

— Make provision to remove the appliance without the need to dismantle the chimney.

— Any existing flue must be confirmed as suitable for the new intended use as defined in the Building Regulations.

— The flue or chimney systems must be inspected and swept to confirm the system is structurally sound and free from obstructions.

— If the chimney is believed to have previously served an open fire it must be swept a second time within a month of regular use after installation to clear any soot falls that may have occurred due to difference in combustion levels.

— The flue exit from the building must comply with local building control rules†.

— Chimney heights and/or separations may need to be increased in particular cases where wind exposure, surrounding tall buildings, high trees or high ground could have adverse effects on flue draught.

— Do not connect or share the flue or chimney system with another heating appliance.

- 2.3 Do not connect to systems containing large voids or spaces over 230mm square.

- 2.4 Suitable access must be provided to enable the collection and removal of debris.

- 2.5 The flue must be swept and inspected when the appliance is installed.

Flue Draught

The flue draught must be checked with all windows and doors closed and any extraction fans in this, or adjoining rooms, running at maximum speed (see Installation Checklist for ventilation requirements).

Twin Wall Flue System

If this appliance is to be used in conjunction with a twin wall flue system then Stovax recommend the use of their Professional XQ range. Details of this product are available from your Stovax retailer.



In the U.K:

*BS 15287-1 and the requirements of Building Regulations

**This should be done by a NACS registered (UK only)/INFO registered (Eire only) chimney sweep, who will issue you with a certificate.

† Building Regulations Document J

Flue Plate:

Where a hearth, fireplace, flue or chimney is provided or extended (including cases where a flue is provided as part of refurbishment work), information essential to the correct appliance and use of these should be permanently posted in the building, to meet Requirement J4 of the Building Regulations (England and Wales), F3.12 (Scotland).

Additional:

A new factory made system that complies to EN 1856; Part 1 can be used providing installation is to the requirements of:

- i) BS 7566 Parts 1 -4
- ii) the manufacturer's instructions
- iii) Building Regulations.

For a guide containing information on Chimneys and Flues contact:

The British Flue & Chimney Manufacturers' Association,
FETA
2 Waltham Court
Milley Lane
Hare Hatch
Reading
Berkshire RG10 9TH

Tel: 0118 9403416

e-mail: info@feta.co.uk

Technical Appendix - Ventilation

3. Ventilation

- 3.1 Many older buildings are sufficiently ventilated by natural leakage of air to provide suitable air supply for an appliance of 5kW output or less.
- Modern building techniques have reduced the amount of air that leaks in or out of a house. A modern construction with an air tightness of less than 5m³ per hour per m² requires an air vent for **ALL** solid fuel appliances including those with a rated heat output of less than 5kW.
- NOTE: The air leakage of a modern house is tested at the completion of construction and a certificate issued confirming this.
- 3.2 This appliance requires a constant supply of air to maintain proper combustion and effective flue performance.
- 3.3 An inadequate air supply can result in poor combustion and smoke entering the room which is potentially dangerous.
- 3.4 This supply of air can come from either:
- Purpose provided ventilation.
 - Some Stovax appliances can also be fitted with an optional outdoor air kit which allows air to be drawn in from the outside.
- 3.5 The amount of air required must comply with local building regulations and the rules in force.
- 3.6 If spillage is detected during commissioning then there may be insufficient natural ventilation and an additional air supply will be necessary.
- 3.7 Permanent air vents should be non-adjustable and positioned where they are unlikely to become blocked.
- 3.8 If vents open into adjoining rooms or spaces there must be an air vent of at least the same size direct to the outside.
- 3.9 Site the vents where cold draught is unlikely to cause discomfort. This can be avoided by placing vents near ceilings or close to the appliance (See diagram).
- 3.10 Extractor fans or cooker hoods must not be placed in the same room or space as this can cause the appliance to emit fumes into the room.
- 3.11 Increase air supply provisions where a room contains multiple appliances.
- 3.12 **If any checks reveal problems do not proceed with the fitting of the appliance until they have been rectified.**

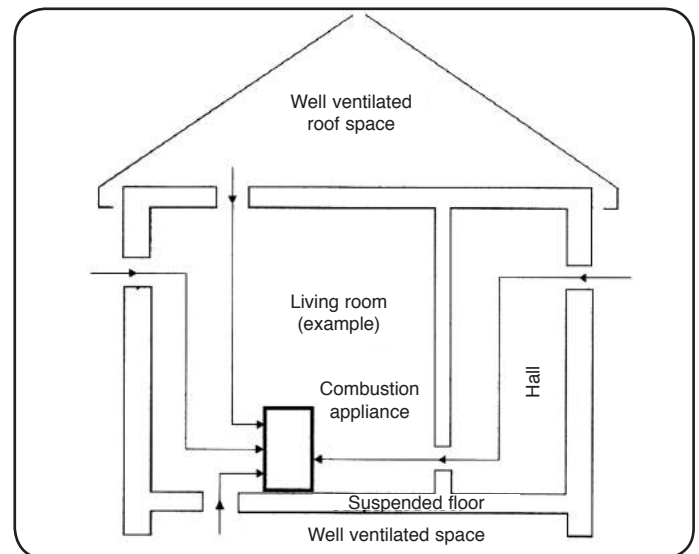

4. Minimum Dimensions - Hearth

- 4.1 The appliance must stand on a non-combustible constructional hearth which is at least 125mm thick with the minimum dimensions as shown in diagram. As this appliance can be installed in an elevated setting it is recommended to increase the 225mm hearth depth to safely contain any falling logs or embers. The higher the appliance is installed the deeper the hearth should be to protect the floor.
- 4.2 The building must have a suitable load-bearing capacity for the hearth and appliance. Consult a structural engineer for advice before proceeding.
- 4.3 When fitting into an existing hearth check that the appliance complies with current construction regulations and is at least the minimum sizes shown.
- 4.4 If there is no existing fireplace or chimney it is possible to construct a suitable non-combustible housing and hearth setting. The flue must be installed in accordance with all local and national regulations and current rules in force.
- 4.5 Check if adding a new chimney to your property requires planning permission.
- 4.6 Some houses are built using a timber frame construction with high levels of thermal insulation. Isolate the appliance from combustible materials, and provide sufficient ventilation to maintain the heating efficiency.

Technical Appendix - Ventilation

5. Fitting Appliances On A Boat

- 5.1 If an appliance is to be fitted in a boat it must be done in accordance with the latest edition of BS 8511 (Code of Practice for the Installation of Solid Fuel Heating Appliances on Boats). The Code covers the design, installation and operation of solid fuel heating appliances that are suitable for fitting into inland waterway boats, and gives guidance on product selection, design considerations, installation requirements, inspection and testing, as well as maintenance and safe use tips.
- 5.2 Consideration should also be given to the requirements of the Boat Safety Scheme (BSS) to ensure the boat's insurance remains valid.
- 5.3 The appliance should only be installed by a competent person with experience of the latest edition of BS 8511 and the Boat Safety Scheme (BSS).
- 5.4 Secure the product to a suitably constructed non-combustible hearth.
- 5.5 All open flued appliances can be affected by temporary atmospheric conditions which may allow fumes to enter the boat. An electronic carbon monoxide detector conforming to the latest edition of BSEN50292 must be fitted and maintained.
- 5.6 Failure to safely install the appliance could endanger the boat and persons on board.



Organisations authorised to certify competence in the installation of domestic solid fuel appliances (Competent Persons Scheme):

APHC - Association of Plumbing and Heating Contractors (Certification) Ltd.
www.aphc.co.uk

BESCA - Building Engineering Services Competence Accreditation Ltd.
www.besca.org.uk

HETAS - Heating Equipment Testing and Approval Scheme Ltd.
www.hetas.co.uk

NAPIT - National Association of Professional Inspectors and Testers Ltd.
www.napit.org.uk

NICEIC - NICEIC Group Ltd.
www.niceic.org.uk

HETAS Approved Chimney Sweeps:

NACS - The National Association of Chimney Sweeps
www.chimneyworks.co.uk

APICS - The Association of Master Chimney Sweeps Ltd.
www.apics.org

The Guild of Master Chimney Sweeps -
guildofmasterchimneysweeps.co.uk

Information Requirement - Solid Fuel

Product Fiche - Information Requirement for Solid Fuel Local Space Heater

Model	Studio 500	Studio 1	Studio 2	Studio 3
Direct Efficiency Class	A+	A	A	A+
Direct Heat Output (kW)	4.90	5.00	8.00	11.00
Indirect Output (kW)	-	-	-	-
Energy Efficiency Index (EEI)	107	99	99	100
Useful Energy Efficiency at Nominal Heat Output	80%	75%	75%	76%
Safety Precautions	Appliance must be installed, Used and Maintained in accordance with the manufacturers instructions supplied			

Basic Spare Parts

RVFST-500 STUDIO 500

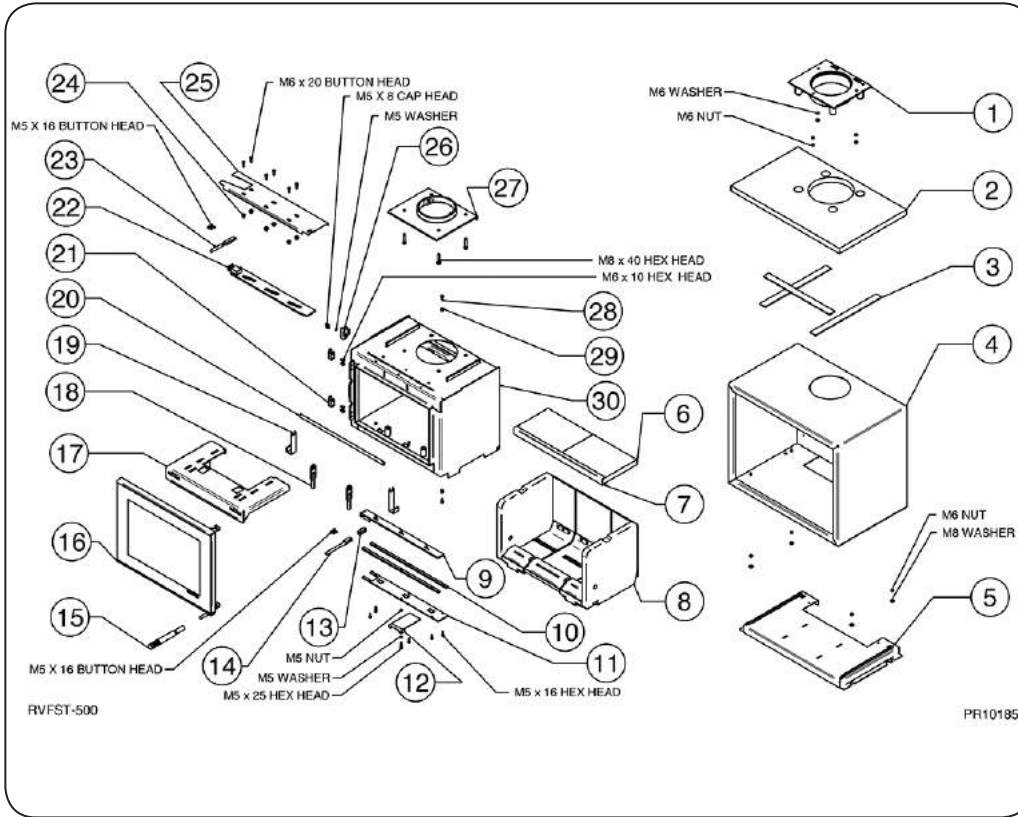

Ref. No.	Description
1	TOP COLLAR
2	TOP INSULATION
3	INSULATION SUPPORT STRIPS
4	FREESTANDING WELDED BOX ASSEMBLY
5	INTERNAL BASE ASSEMBLY
6	BAFFLE BRICK
7	BAFFLE SUPPORT
8	BRICK ASSEMBLY
9	PRIMARY SLIDER ASSEMBLY
10	PRIMARY AIR SLIDER RUNNER
11	PRIMARY AIR SLIDER COVER
12	DATA PLATE MOUNT
13	PRIMARY AIR SC KIT BRACKET
14	PRIMARY AIR HANDLE
15	TOOL HANDLE
16	DOOR ASSEMBLY
17	TOP BAFFLE ASSEMBLY
18	LOG BAR SUPPORT ASSEMBLY
19	LOG GUARD END SUPPORT
20	LOG BAR
21	HINGE BLOCK ASSEMBLY
22	AIRWASH SLIDER
23	AIRWASH HANDLE
24	AIRWASH SPACER
25	AIRWASH SLIDER COVER
26	AIRWASH SC KIT BRACKET
27	LOWER COLLAR
28	CATCH ROLLER PIN
29	CATCH ROLLER
30	INNER BOX ASSEMBLY

DOOR ASSEMBLY

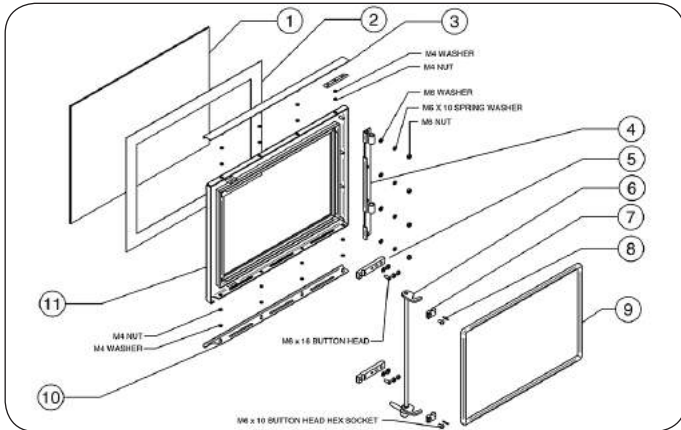

Ref. No.	Description
1	DOOR GLASS
2	GLASS ROPE
3	TOP GLASS ASSEMBLY
4	HINGE ASSEMBLY
5	LOWER CATCH BLOCK
6	DOOR CATCH ASSEMBLY
7	UPPER CATCH BLOCK
8	DOOR ROPE
9	SPIROL PIN Ø3 X 18 LG
10	GLASS CLAMP BASE ASSEMBLY
11	DOOR FRAME ASSEMBLY

BRICK ASSEMBLY

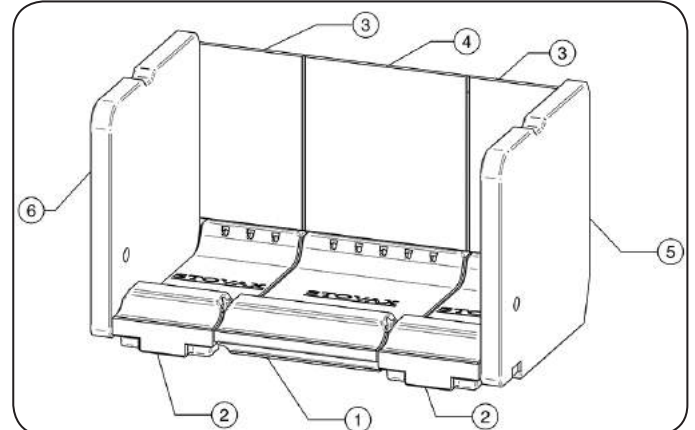

Ref. No.	Description
1	BASE CENTRE BRICK
2	BASE SIDE BRICK
3	REAR SIDE BRICK
4	REAR CENTRE BRICK
5	SIDE BRICK RIGHT HAND SIDE
6	SIDE BRICK LEFT HAND SIDE

i Due to continual technical improvements please check online or with your Stovax retailer for the most up to date parts lists. Only use Genuine Stovax spares when servicing your appliance. All of our essential spare parts and consumable items are available to purchase from our webshop at www.stovaxspares.com.

Basic Spare Parts

RVFST-1HT STUDIO 1

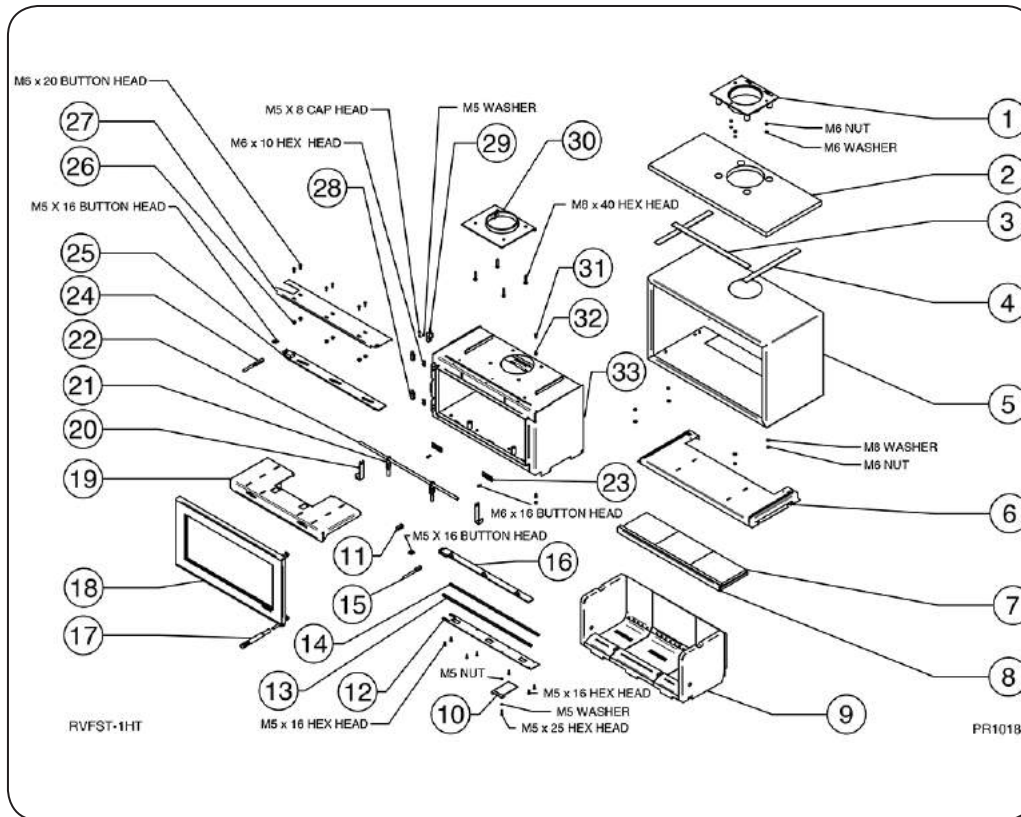

Ref. No.	Description
1	TOP COLLAR
2	TOP INSULATION
3	INSULATION SUPPORT STRIPS (MIDDLE)
4	INSULATION SUPPORT STRIPS
5	FREESTANDING WELDED BOX ASSEMBLY
6	INTERNAL BASE ASSEMBLY
7	BAFFLE BRICK
8	BRICK BAFFLE SUPPORT
9	WOOD BRICK ASSEMBLY
10	SKAMOL
11	DATA PLATE MOUNT
12	PRIMARY AIR SC KIT STOP
13	PRIMARY AIR SLIDER COVER PLATE
14	PRIMARY AIR SLIDER RUNNER
15	PRIMARY AIR SLIDER
16	PRIMARY AIR HANDLE
17	TOOL HANDLE
18	DOOR ASSEMBLY
19	TOP BAFFLE ASSEMBLY
20	LOG GUARD END SUPPORT
21	LOG GUARD SUPPORT ASSY
22	LOG GUARD
23	SECONDARY AIR CONTROL SLIDER
24	AIRWASH HANDLE
25	AIRWASH SLIDER
26	AIRWASH SPACER
27	AIRWASH SLIDER COVER
28	HINGE BLOCK ASSEMBLY
29	AIRWASH SC KIT BRACKET
30	LOWER COLLAR
31	CATCH ROLLER PIN
32	CATCH ROLLER
33	INNER BOX ASSEMBLY

DOOR ASSEMBLY

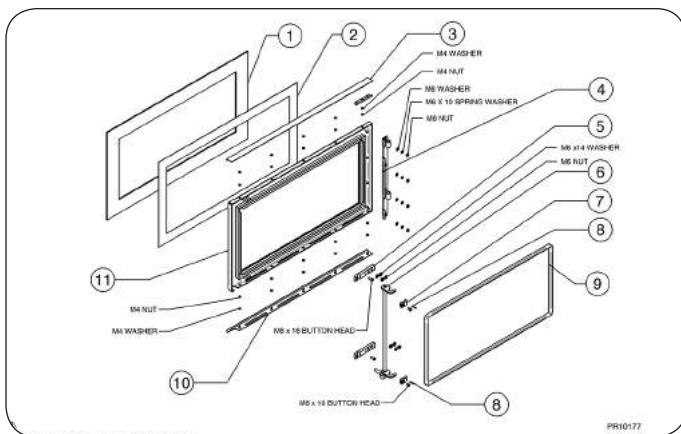

Ref. No.	Description
1	STUDIO 1 DOOR GLASS
2	GLASS ROPE
3	TOP GLASS CLAMP ASSEMBLY
4	HINGE ASSEMBLY
5	LOWER CATCH BLOCK
6	DOOR CATCH ASSEMBLY
7	UPPER CATCH BLOCK
8	SPIROL PIN Ø3 X 18LG
9	DOOR ROPE
10	BOTTOM GLASS CLAMP
11	DOOR FRAME ASSEMBLY

BRICK ASSEMBLY

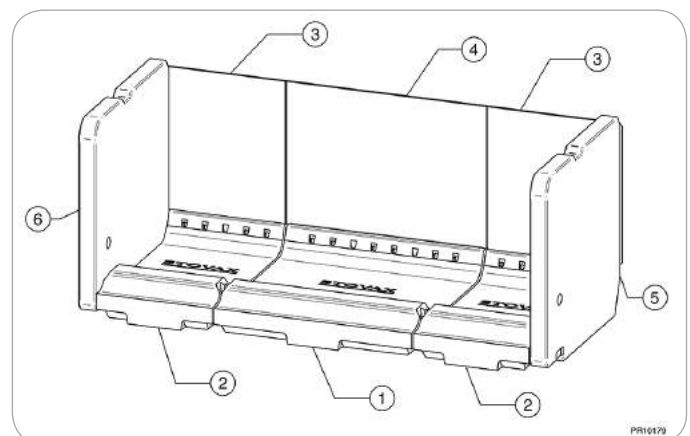

Ref. No.	Description
1	BASE CENTRE BRICK
2	BASE SIDE BRICK
3	REAR SIDE BRICK
4	REAR CENTRE BRICK
5	SIDE BRICK RIGHT HAND SIDE
6	SIDE BRICK LEFT HAND SIDE

i Due to continual technical improvements please check online or with your Stovax retailer for the most up to date parts lists. Only use Genuine Stovax spares when servicing your appliance. All of our essential spare parts and consumable items are available to purchase from our webshop at www.stovaxspares.com.

Basic Spare Parts

RVFST-2HT STUDIO 2

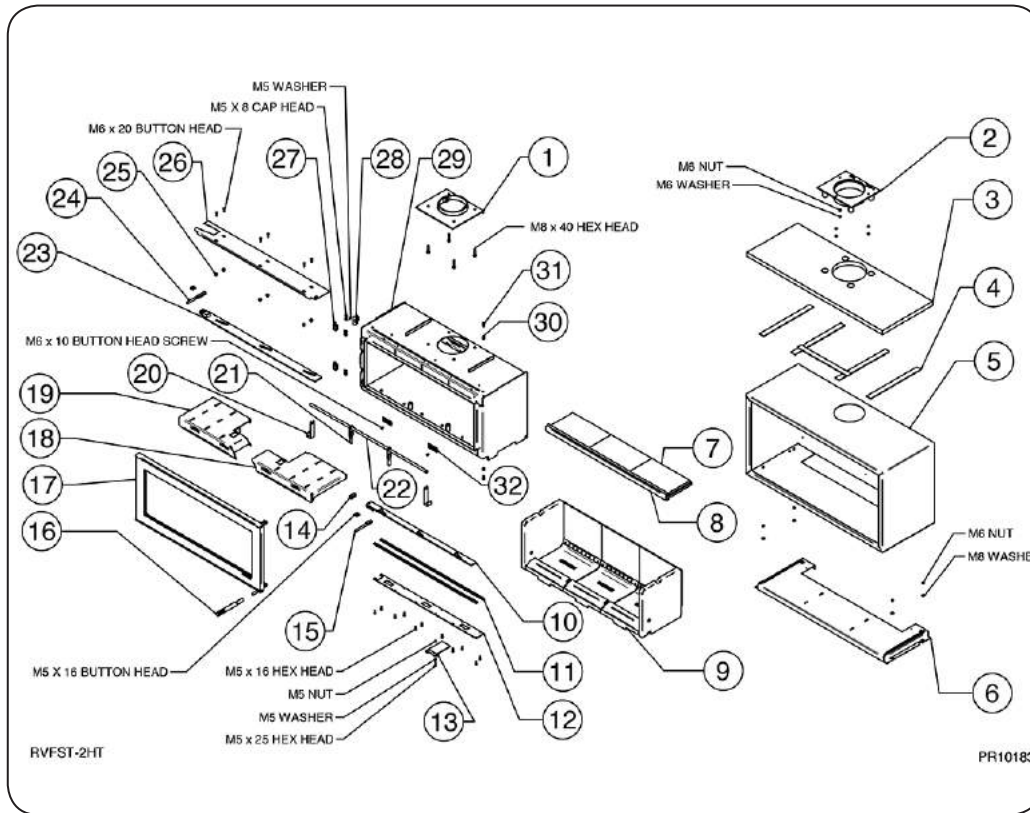

Ref. No.	Description
1	LOWER COLLAR
2	TOP COLLAR
3	TOP INSULATION
4	INSULATION SUPPORT STRIPS
5	FREESTANDING WELDED BOX ASSEMBLY
6	INTERNAL BASE ASSEMBLY
7	BAFFLE BRICK
8	BAFFLE BRICK SUPPORT
9	BRICK ASSEMBLY
10	PRIMARY SLIDER
11	SPACER PLATE
12	PRIMARY PLATE
13	DATA PLATE MOUNT
14	PRIMARY AIR SC KIT BRACKET
15	PRIMARY AIR HANDLE
16	TOOL HANDLE
17	DOOR ASSEMBLY
18	TOP BAFFLE RHS
19	TOP BAFFLE LHS
20	LOG GUARD END SUPPORT
21	LOG GUARD SUPPORT ASSEMBLY
22	LOG GUARD
23	AIRWASH SLIDER
24	AIRWASH HANDLE
25	AIRWASH SPACER
26	AIRWASH SLIDER COVER
27	HINGE BLOCK ASSEMBLY
28	AIRWASH SC KIT BRACKET ASSY
29	INNER BOX ASSEMBLY
30	CATCH ROLLER
31	CATCH ROLLER PIN

DOOR ASSEMBLY

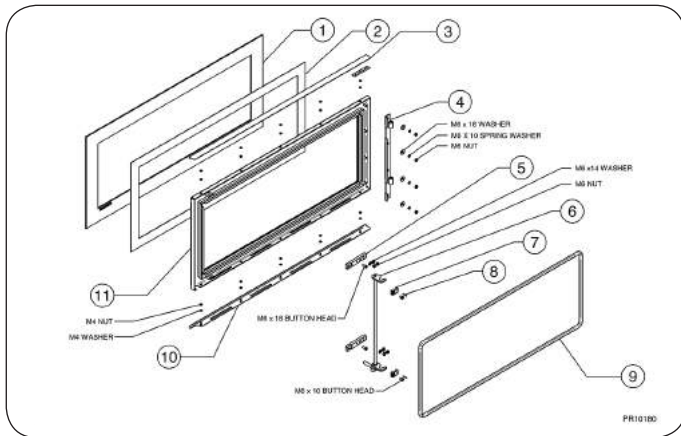

Ref. No.	Description
1	STUDIO 2 DOOR GLASS
2	GLASS ROPE
3	TOP GLASS CLAMP ASSEMBLY
4	HINGE ASSEMBLY
5	LOWER CATCH BLOCK
6	DOOR CATCH ASSEMBLY
7	UPPER CATCH BLOCK
8	SPIROL PIN Ø3 X 18LG
9	DOOR ROPE
10	BOTTOM GLASS CLAMP
11	DOOR FRAME ASSEMBLY

BRICK ASSEMBLY

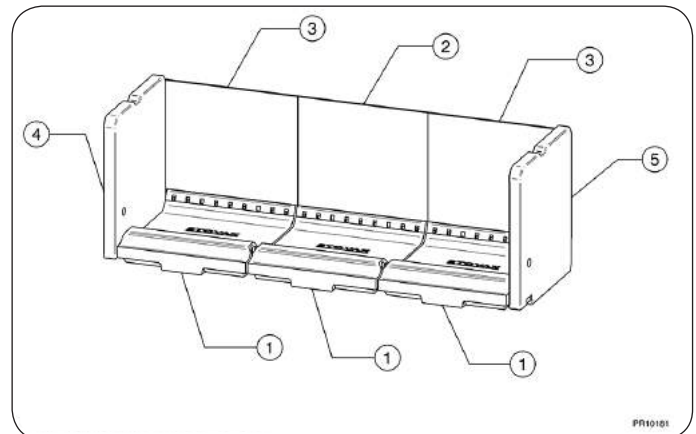

Ref. No.	Description
1	BASE BRICK
2	BACK BRICK
3	BACK BRICK SIDE
4	SIDE BRICK LEFT HAND SIDE
5	SIDE BRICK RIGHT HAND SIDE

i Due to continual technical improvements please check online or with your Stovax retailer for the most up to date parts lists.
Only use Genuine Stovax spares when servicing your appliance.
All of our essential spare parts and consumable items are available to purchase from our webshop at www.stovaxspares.com.

Basic Spare Parts

RVFST-3HT STUDIO 3

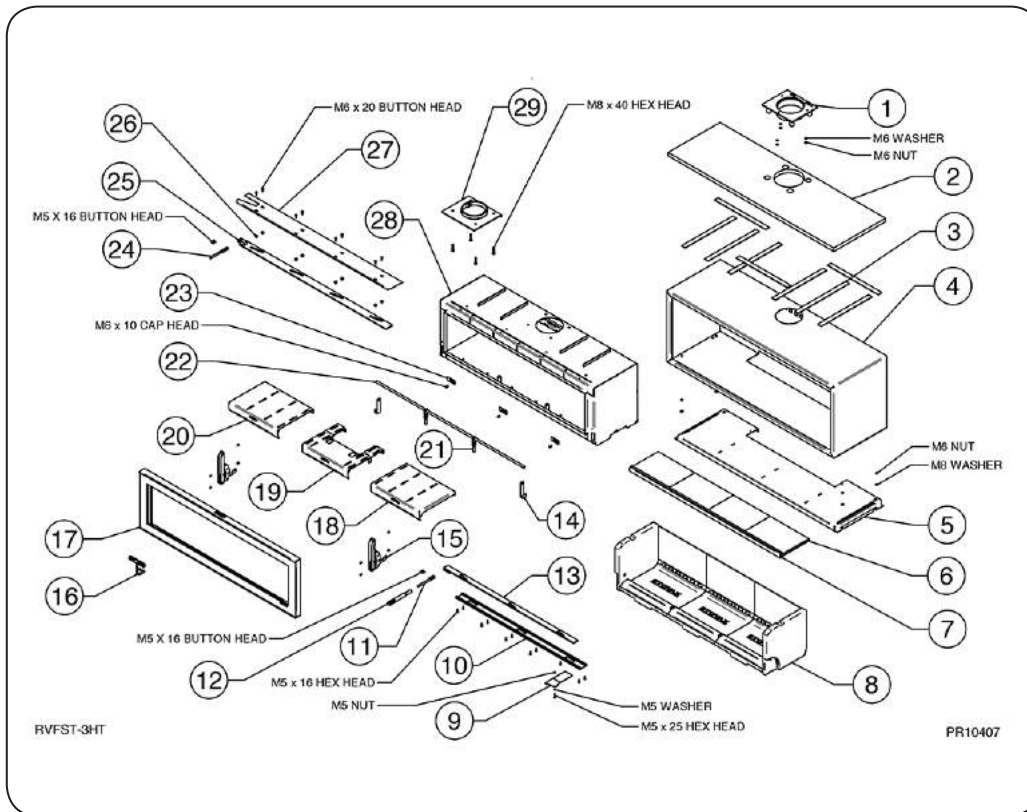

Ref. No.	Description
1	TOP FLUE COLLAR
2	TOP INSULATION
3	INSULATION SUPPORT STRIPS
4	FREESTANDING WELDED BOX ASSEMBLY
5	INTERNAL BASE ASSEMBLY
6	BAFFLE BRICK
7	BAFFLE SUPPORT
8	BRICK ASSEMBLY
9	DATA PLATE MOUNT
10	PRIMARY AIR SLIDER COVER ASSEMBLY
11	PRIMARY AIR HANDLE
12	TOOL HANDLE
13	PRIMARY SLIDER
14	LOG GUARD END SUPPORT
15	HINGE
16	DOOR TOOL
17	DOOR ASSEMBLY
18	BAFFLE RHS
19	CENTRE BAFFLE
20	BAFFLE LHS
21	LOG GUARD SUPPORT ASSY
22	LOG GUARD
23	SECONDARY AIR CONTROL SLIDER
24	AIRWASH HANDLE
25	AIRWASH SLIDER
26	AIRWASH SPACER
27	AIRWASH SLIDER COVER
28	INNER BOX ASSEMBLY
29	LOWER COLLAR

DOOR ASSEMBLY

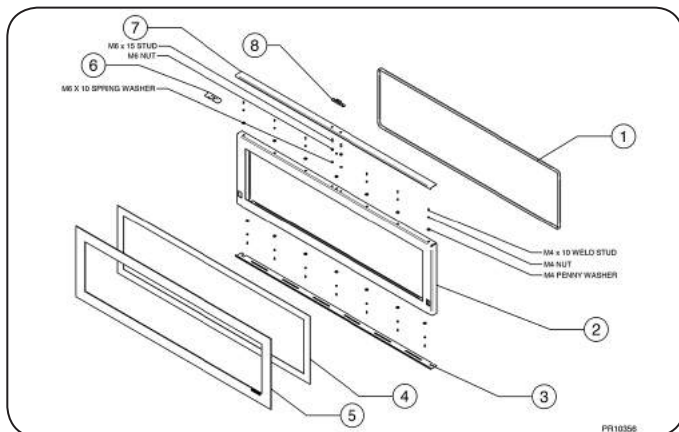

Ref. No.	Description
1	DOOR ROPE
2	DOOR FRAME ASSEMBLY
3	BOTTOM GLASS CLAMP ASSEMBLY
4	GLASS ROPE
5	STUDIO 3 DOOR GLASS
6	HANDLE SUPPORT
7	TOP GLASS CLAMP
8	DOOR OPENING BLOCK

BRICK ASSEMBLY

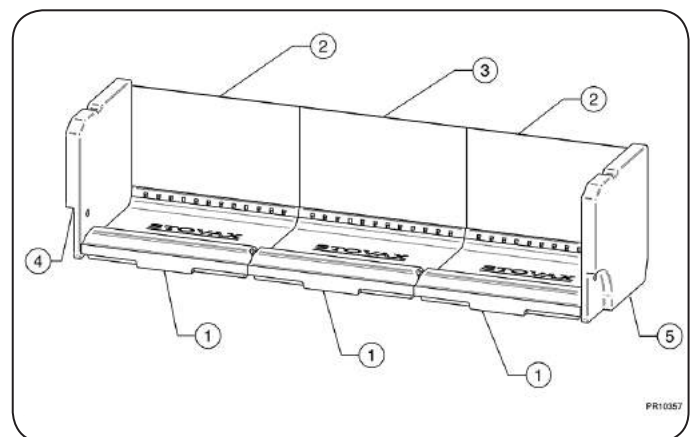

Ref. No.	Description
1	BASE BRICK
2	REAR SIDE BRICK
3	REAR CENTRE BRICK
4	SIDE BRICK LEFT HAND SIDE
5	SIDE BRICK RIGHT HAND SIDE

i Due to continual technical improvements please check online or with your Stovax retailer for the most up to date parts lists.
Only use Genuine Stovax spares when servicing your appliance.
All of our essential spare parts and consumable items are available to purchase from our webshop at www.stovaxspares.com.

Service Records

1ST SERVICE

Date of Service:.....

Next Service Due:.....

Signed:.....

Dealer's Stamp/HETAS Registration Number

3RD SERVICE

Date of Service:.....

Next Service Due:.....

Signed:.....

Dealer's Stamp/HETAS Registration Number

5TH SERVICE

Date of Service:.....

Next Service Due:.....

Signed:.....

Dealer's Stamp/HETAS Registration Number

7TH SERVICE

Date of Service:.....

Next Service Due:.....

Signed:.....

Dealer's Stamp/HETAS Registration Number

9TH SERVICE

Date of Service:.....

Next Service Due:.....

Signed:.....

Dealer's Stamp/HETAS Registration Number

2ND SERVICE

Date of Service:.....

Next Service Due:.....

Signed:.....

Dealer's Stamp/HETAS Registration Number

4TH SERVICE

Date of Service:.....

Next Service Due:.....

Signed:.....

Dealer's Stamp/HETAS Registration Number

6TH SERVICE

Date of Service:.....

Next Service Due:.....

Signed:.....

Dealer's Stamp/HETAS Registration Number

8TH SERVICE

Date of Service:.....

Next Service Due:.....

Signed:.....

Dealer's Stamp/HETAS Registration Number

10TH SERVICE

Date of Service:.....

Next Service Due:.....

Signed:.....

Dealer's Stamp/HETAS Registration Number

The Clean Air Act 1993 and Smoke Control Areas

Under the Clean Air Act local authorities may declare the whole or part of the district of the authority to be a smoke control area. It is an offence to emit smoke from a chimney of a building, from a furnace or from any fixed boiler if located in a designated smoke control area. It is also an offence to acquire an “unauthorised fuel” for use within a smoke control area unless it is used in an “exempt” appliance (“exempted” from the controls which generally apply in the smoke control area).

The Secretary of State for Environment, Food and Rural Affairs has powers under the Act to authorise smokeless fuels or exempt appliances for use in smoke control areas in England. In Scotland and Wales this power rests with Ministers in the devolved administrations for those countries. Separate legislation, the Clean Air (Northern Ireland) Order 1981, applies in Northern Ireland. Therefore it is a requirement that fuels burnt or obtained for use in smoke control areas have been “authorised” in Regulations and that appliances used to burn solid fuel in those areas (other than “authorised” fuels) have been exempted by an Order made and signed by the Secretary of State or Minister in the devolved administrations.

Further information on the requirements of the Clean Air Act can be found here:
<http://smokecontrol.defra.gov.uk/>

Your local authority is responsible for implementing the Clean Air Act 1993 including designation and supervision of smoke control areas and you can contact them for details of Clean Air Act requirements”

These Studio models (RVFS-500/RVFS-1/RVFS-2) has been recommended as suitable for use in smoke control areas when burning dry wood logs when suitable permanent stops have been fitted and when operated in accordance with the manufacturer’s instructions.



HETAS Approval

These appliances have been approved by HETAS as an intermittent operating appliance for burning dry seasoned wood logs only.

Recommended Fuels

Please note that HETAS Appliance Approval only covers the use of dry seasoned wood logs on these appliances. HETAS approval does not cover the use of other fuels either alone or mixed with the recommended fuels, nor does it cover instructions for the use of other fuels.

STOVAX

Stovax Ltd, Falcon Road, Sowton Industrial Estate, Exeter, Devon, England EX2 7LF
Tel: (01392) 474011 Fax: (01392) 219932 E-mail: info@stovax.com www.stovax.com

E & O E