

INSTALLER AND OWNER GUIDE



Brunswick



Model 910

GAS STOVE

Fitted with a Ceramic Coal fuel effect.

We trust that this guide gives sufficient details to enable this appliance to be installed, operated and maintained satisfactorily.

However, if further information is required, our

Valor Fires Technical Helpline will be pleased to help.

Telephone **0844 879 35 88** (National call rates apply in the United Kingdom).

In the Republic of Ireland
Telephone **01 842 8222**.



INSTALLER: Please leave this guide with the owner

**THIS APPLIANCE IS FOR USE WITH NATURAL GAS (G20).
WHEN CONVERTED USING CONVERSION KIT NO. 0591011 THIS APPLIANCE
IS FOR USE WITH PROPANE GAS (G31).
THIS APPLIANCE IS SUITABLE ONLY FOR INSTALLATION IN THE UNITED
KINGDOM (GB) AND THE REPUBLIC OF IRELAND (IE).**

© GDC Group Ltd.

All rights reserved. No part of this publication may be reproduced in any material form (including photocopying), stored in any medium by electronic means (including in any retrieval system or database) or transmitted, in any form or by any means, whether electronic, mechanical, recording or otherwise, without the prior written permission of the copyright owner.

Applications for the copyright owner's permission to reproduce any part of this publication should be made, giving details of the proposed use, to the following address: The Marketing Communications Manager, GDC Group Ltd, Millbrook House, Grange Dive, Hedge End, Southampton, SO30 2DF.

Warning: Any person who does any unauthorised act in relation to a copyright work may be liable to criminal prosecution and civil claims for damages.

Because our policy is one of constant development and improvement, details may vary slightly from those given in this publication

INSTALLER GUIDE

FOR OWNER GUIDE SEE PAGES 19 TO 30

INSTALLER GUIDE

LIST OF CONTENTS

<u>Section</u>	<u>Heading</u>	<u>Page</u>
	INSTALLER GUIDE	3 - 18
	OWNER GUIDE	19 - 30
1.	SAFETY	5
2.	APPLIANCE DATA AND EFFICIENCY	6
	General information.	6
	Efficiency.	6
3.	UNPACKING	7
4.	STOVE SET UP	8
	Legs and lower casting cover	8
	Flue collar, diverter box, flue spigot and flue restrictor plate.	8
	Down draught deflector.	9
	Burner module and rear burner support fitment.	10
	Thermal switch.	10
	Diverter box.	10
5.	GENERAL INSTALLATION REQUIREMENTS	11
	Regulations, Standards and Law.	11
	The Hearth.	11
	Clearances.	12
	Flue / Chimney.	12
	Ventilation.	13
	Location.	13
	Propane gas.	13
	Gas connection.	13
	Securing the stove.	13
	Fitting the ceramic fuel effect.	14
6.	OPERATING THE STOVE	14
	Pre-lighting checks.	14
	Lighting the burner.	14
	Operating the burner.	14
	Inlet pressure check.	15
	Check for spillage.	15
	Flame supervision and spillage monitoring system.	15
7.	FINAL REVIEW AND SERVICING	16
	Final Review.	16
	Servicing.	17
	Checking the aeration setting of the burner.	18

INSTALLER GUIDE

1. SAFETY

This product uses fuel effect pieces containing Refractory Ceramic Fibres (RCF), which are man-made vitreous silicate fibres. Excessive exposure to these materials may cause irritation to eyes, skin and respiratory tract. Consequently, it is important to take care when handling these articles to ensure that the release of dust is kept to a minimum. To ensure that the release of fibres from these RCF articles is kept to a minimum, during installation and servicing we recommend that you use a HEPA filtered vacuum to remove any dust and soot accumulated in and around the stove before and after working on the stove. When replacing these articles we recommend that the replaced items are not broken up, but are sealed within a heavy duty polythene bag, clearly labelled as RCF waste. RCF waste is classed as a stable, non-reactive hazardous waste and may be disposed at a landfill licensed to accept such waste. Protective clothing is not required when handling these articles, but we recommend you follow the normal hygiene rules of not smoking, eating or drinking in the work area and always wash your hands before eating or drinking. This appliance does not contain any component manufactured from asbestos or asbestos related products.

Installer

Valor stoves are efficient appliances giving off convected, conducted and radiated heat. All the surfaces of the stove - except the controls - are working surfaces and become hot in use. They must not be touched or have any combustible objects or materials placed on or near them. A fire guard complying with BS 8423 should be fitted for the protection of young children, the elderly, the infirm or pet animals.

The appliance is fitted with a flue safety device. If the appliance closes down after a period of operation for no apparent reason, the consumer should be informed to stop using the appliance until the installation and appliance have been thoroughly checked. Under no circumstances should the flue safety device be altered or bypassed in any way. Only a genuine manufacturers replacement part should be fitted.

Before continuing any further with the installation of this appliance please read the following guide to manual handling:

- The lifting weight of this appliance is 55 kg. We therefore recommend that two people should be sufficient to lift the stove. If fitting or moving the stove alone we recommend the use of suitable lifting apparatus.
- When lifting always keep your back straight. Bend your legs and not your back.
- Avoid twisting at the waist. It is better to reposition your feet.

INSTALLER GUIDE

- Avoid upper body/top heavy bending. Do not lean forward or sideways whilst handling the stove.
- Always grip with the palm of the hand. Do not use the tips of fingers for support.
- Always keep the stove as close to the body as possible. This will minimise the cantilever action.
- Use gloves to provide additional grip.
- Always use assistance if required.

2. APPLIANCE DATA AND EFFICIENCY

General information.

Gas	Natural (G20)	Propane (G31) *
Inlet Pressure	20mbar	37mbar
Input - Max. (Gross)	5.50kW (18,766Btu/h)	5.4kW (18,425Btu/h)
Input - Min. (Gross)	2.3kW (7,850 Btu/h)	3.8kW (12,965Btu/h)
Inlet Test Pressure (Cold)	20.0 ± 1.0mbar (8.0 ± 0.4in w.g.)	37.0 ± 1.0mbar (14.85 ± 0.4in w.g.)
Gas Connection	8mm pipe	8mm pipe
Burner Injector	Cat 82 - 065	Size 116
Pilot	Copreci Ref. O.D.S 21500/212	Copreci Ref. O.D.S 21500/212 Fitted with RBM 180 -02 injector
Ignition	Piezo Electric. Integral with Gas Tap	Piezo Electric. Integral with Gas Tap
Aeration	See page 18	Non-adjustable

*When converted using kit 0591011.

The appliance information label is located on a plate at the base of the stove.

Efficiency.

The efficiency of this appliance has been measured as specified in BS EN 613 and the result is as below :

<u>Model</u>	<u>Efficiency % (Gross)</u>
910	73.1
910 when converted to LPG.	73.1

INSTALLER GUIDE

The gross calorific value of the fuel has been used for this efficiency calculation. The test data from which it has been calculated has been certified by BSI.

The efficiency value may be used in the UK Government's Standard Assessment Procedure (SAP) for energy rating of dwellings.

The conversion of **net** efficiency to **gross** was achieved by multiplying the net efficiency by the following conversion factor from Table E3 of SAP 2005, rounding down to the nearest whole number.

Gas	Conversion factor from net to gross efficiency
Natural Gas	0.901
LPG	0.921

3. UNPACKING

Before installation, check that the following components, where required, have been delivered.

- Loose parts box -** Contains the flue spigot, four feet, lower front panel, restrictor plate and touch up paint.
+
- Accessory Pack -** Contains bolts, nuts, washers, wall plugs and screws.
- Ceramic box -** Contains ceramic coal set.
- Stove Burner Assy box -** Contains 910 burner module including rear burner support & knob assy. Item number 05910X1.
- Inside Stove Casting -** Contains the down draught deflector and diverter box.

INSTALLER GUIDE

NOTE: The door is secured with a locking bolt and Hex nut. To open the door use a 3mm Allen key to loosen the hex nut on the side of the door, being careful not to remove it completely. Ref to Figure A below. Then select a suitably sized spanner and turn counter clockwise by approximately a quarter turn on the handle to open.

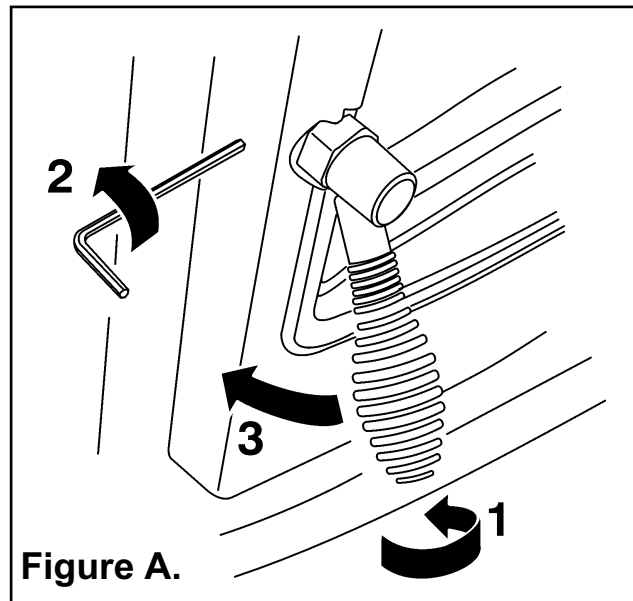

4. STOVE SET UP

Legs and lower front panel cover (See figure 1).

- Locate the four leg securing studs into the four holes in the base of the body.
- Locate the four legs to the underside of the casting body. There are two feet with holes in the base. We recommend that these be placed at the rear of the stove.
- Place the front panel cover on top of the front legs.

– Secure the legs and front panel cover to the underside of the casting body using the nuts and washers supplied.

Flue collar, diverter box, flue spigot and flue restrictor plate.

– These should be located to the stove as in figure 2. Do not bolt in place until fitting the deflector. The flue restrictor is for use where the flue draught is excessive. The flue spigot is screwed to the cast flue collar and clamps the flue restrictor plate in place (See figure 2).

There may however, be certain circumstances where fitting the restrictor causes the fire to fail the spillage test. In such cases the restrictor will have to be removed. After removal conduct the spillage check again.

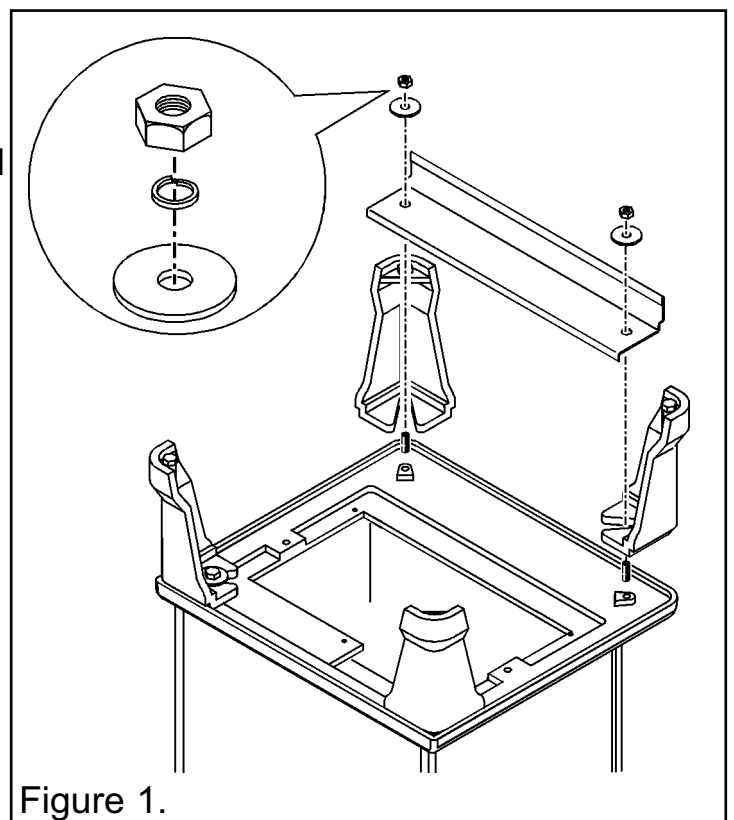
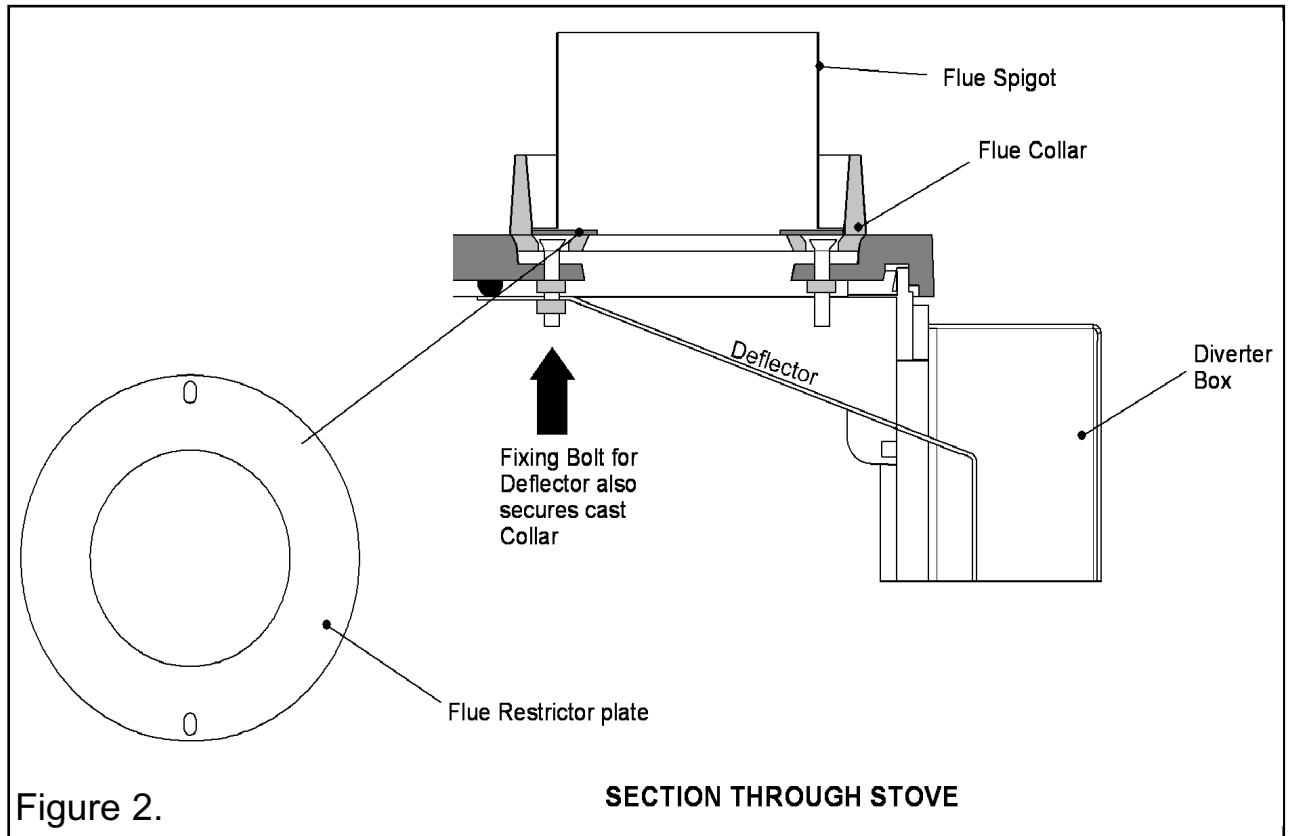

Figure 1.

INSTALLER GUIDE



Down draught deflector.

– The down draught deflector is secured in place using the upper front bolt and nut that secure the cast collar to the outside of the cast body. Unscrew and remove the nut and washer from inside the top of the casting body. Position the down draught deflector as in figure 3. It **MUST** be sealed against the top of the stove casting. It is important that it sits on top and between the raised cast areas on the rear of the stove body (See figure 3). Secure in place using the nut and washer removed previously.

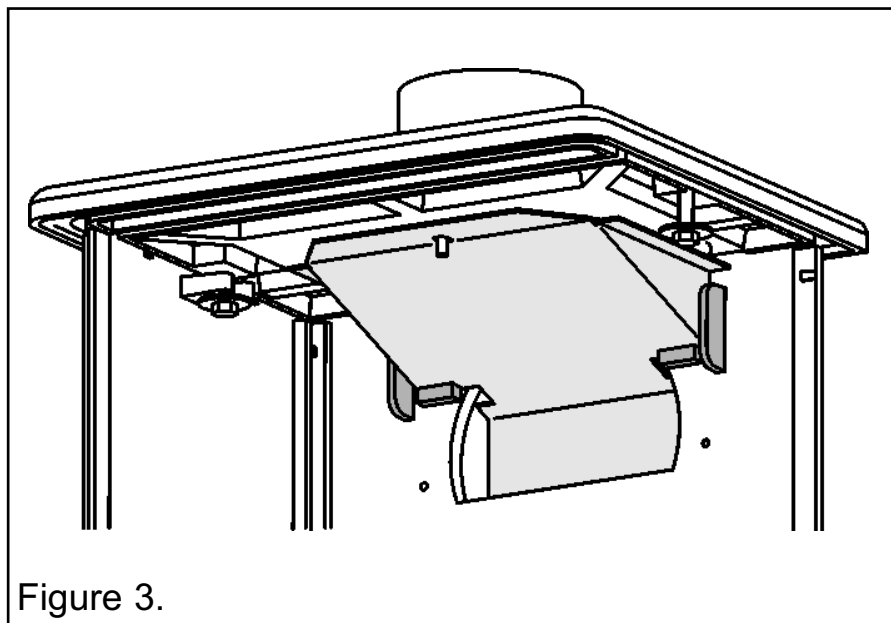

INSTALLER GUIDE

Thermal switch.

The Thermal Switch should be fitted to the inside of the Diverter Box as in figure 4. Secure using the nut and bolt supplied. Never modify the fixing bracket and always ensure that the switch is fitted correctly. NEVER USE THE STOVE IF THE THERMAL SAFETY SWITCH HAS BEEN REMOVED OR IF IT IS DAMAGED IN ANY WAY.

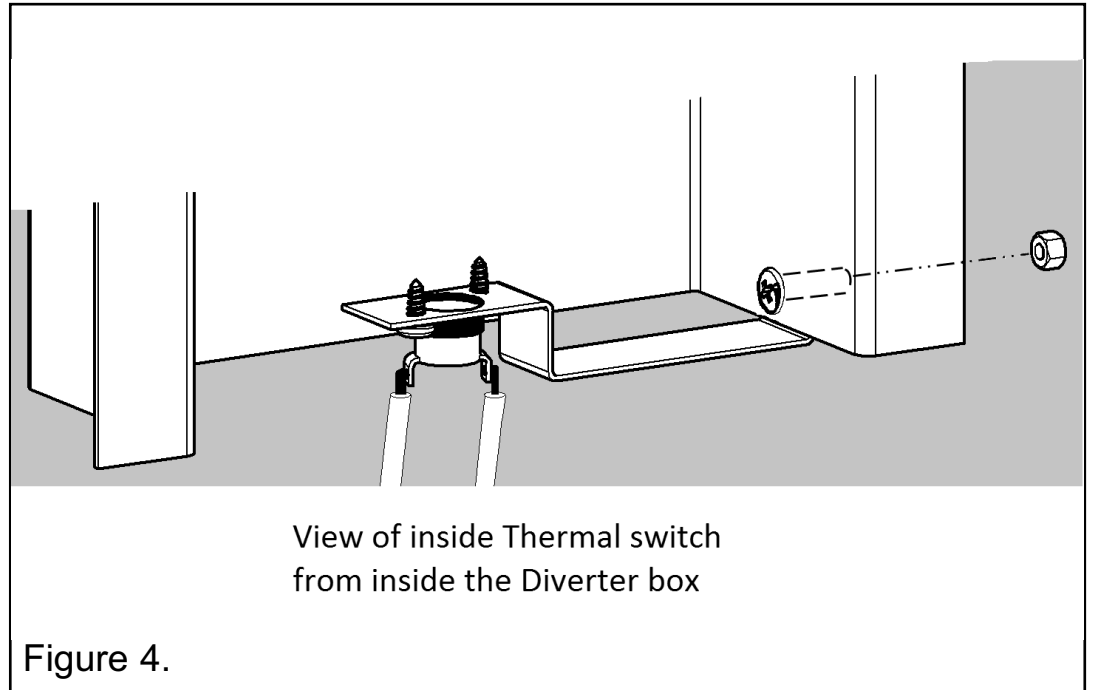

Diverter box.

Locate the diverter box to the rear of the stove body and secure in place using the bolts and washers supplied.

Burner module.

– Ensure the rear ceramic support is fitted as shown in Fig 5 with the three screws supplied in with the knob assy kit onto the rear of the burner module.

– Secure the control knob assembly to the gas valve, the screw tail should secure onto the flat on the gas valve spindle.

- Connect the thermal switch leads to the tags mid way along the thermocouple.

– Locate the burner assembly inside the stove body as in Fig 5 (The outer front of the stove is not shown for clarity).

The rear leg of the burner should sit on the rear of the casting. Secure using the three screws supplied. The screw locations are shown in figure 5).

– Secure the control knob assembly to the gas valve, the screw tail should secure onto the flat on the gas valve spindle.

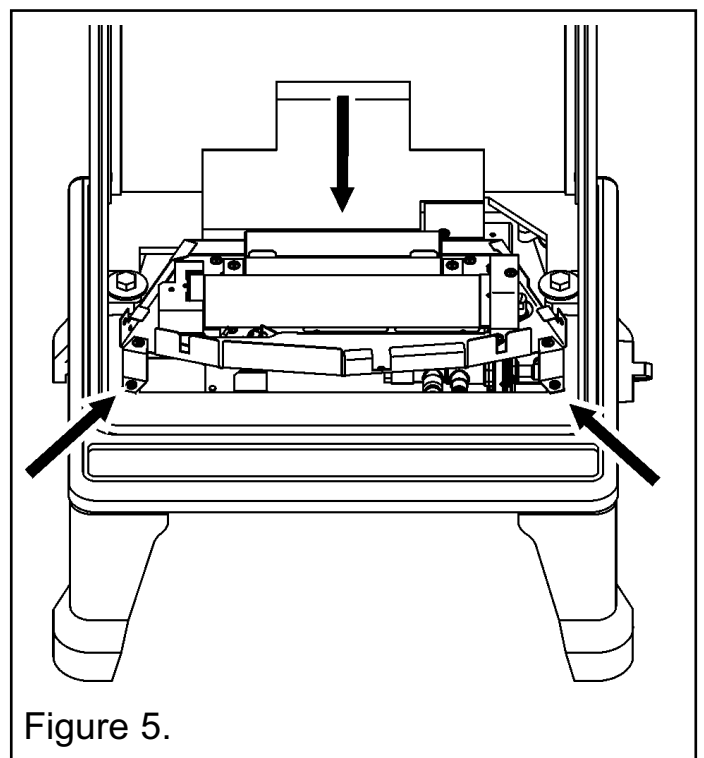

INSTALLER GUIDE

5. GENERAL INSTALLATION REQUIREMENTS

Regulations, Standards and Law.

The installation must be in accordance with these instructions.

For the user's protection, in the United Kingdom it is the law that all gas appliances are installed by competent persons in accordance with the current edition of the Gas Safety (Installation and Use) Regulations. Failure to install the appliance correctly could lead to prosecution. GAS SAFE REGISTER and CORGI require their members to work to recognised standards.

In the United Kingdom the installation must also be in accordance with all the relevant parts of local regulations.

BS 5440 Part 1

BS 5440 Part 2

BS 4543 Part 2

BS 5871 Part 1

BS 6891

BS 8303

In England and Wales, the current edition of the Building Regulations issued by the Department of the Environment and the Welsh Office.

In Scotland, the current edition of the Building Standards (Scotland) Regulations issued by the Scottish Executive.

In Northern Ireland, the current edition of the Building regulations (Northern Ireland) issued by the Department of the Environment for Northern Ireland.

In the republic of Ireland the installation must be carried out by a competent person and also conform to the relevant parts of:

- a) The current edition of IS 813 "Domestic Gas Installations"
- b) All relevant national and local rules in force.

Where no specific instructions are given, reference should be made to the relevant British Standard Code of Practice.

The Hearth.

The appliance must be mounted on a non-combustible hearth (N.B. conglomerate marble hearths are considered as non-combustible). The hearth material must be at least 12mm thick. The hearth must protrude at least 150mm (6") in front of the stove body. In most buildings with solid concrete floors this requirement will be met by the floor itself.

INSTALLER GUIDE

Clearances.

Clearances from combustible and non-combustible materials must be at least those shown in figure 6.

IMPORTANT: Reducing the clearance distance at the rear of the stove (especially with non-combustible surfaces) can result in the stove switching off. This occurs when the thermal switch operates due to insufficient cool air.

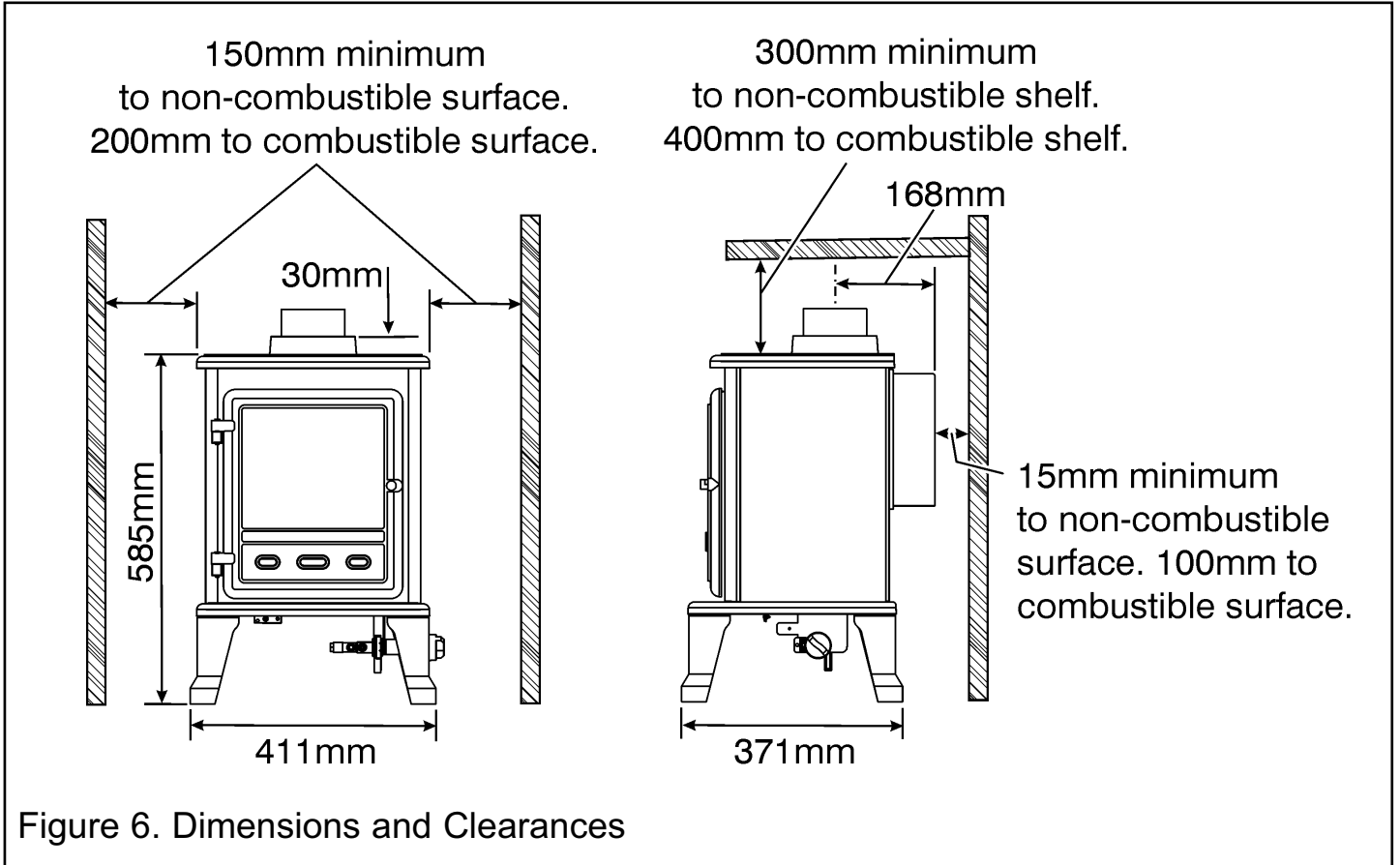

Flue / Chimney.

– The stove is approved for use with 102mm (4 inch) diameter insulated Selkirk insta - lock gas vent.

– The spigot is designed to be compatible with a selkirk 4 SIL - DH draft hood connector. The inner sleeve will require reducing in length so that it protrudes 25mm below the outer sleeve (See figure 7).

– Before you install the stove make sure the chimney flue outlet is correctly positioned to align with the flue outlet on the stove and that the chimney is in good condition. If not, a chimney liner must be installed or a suitable class 2 gas flue used. A draught is necessary to ensure the products of combustion are fully evacuated. Connect and seal the stove flue collar to the chimney using full depth of collar. The flue must have a minimum effective height of 3 metres (10ft), however to,

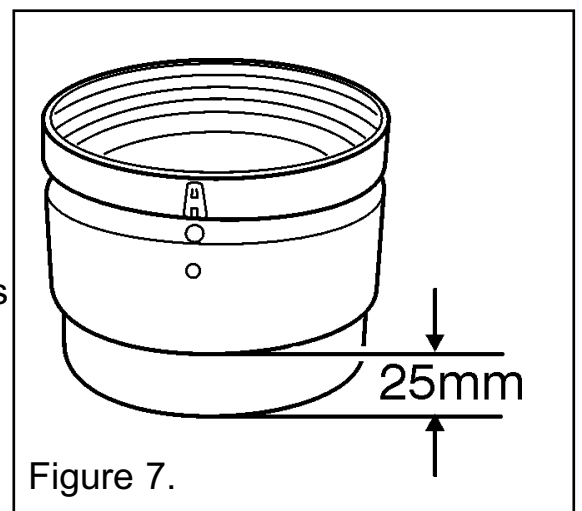

INSTALLER GUIDE

ensure optimum performance we recommend 3.66 metres (12ft) or higher. The flue must be free of obstruction and any dampers must be fixed in a permanently open position. Ensure that the chimney is not closed and that it has been swept prior to the stove being installed. Make sure that rain, birds or any foreign bodies cannot get into the chimney and cause blockage or damage. This problem can normally be overcome by fitting an approved Gas Cowl. It is essential to the effective running of your stove that the chimney draws properly and allows the products of combustion to escape.

Ventilation.

– Normal adventitious ventilation is usually sufficient to satisfy the ventilation requirements of this appliance. In GB reference should be made to BS5871 Part 1 and in IE reference should be made to the current edition of IS 813 “ Domestic gas installations” which make clear the conditions that must be met to demonstrate that sufficient ventilation is available.

– An extractor fan may only be used in the same room as this appliance, or in any area from which ventilation for the appliance is taken, if it does not affect the safe performance of the appliance. Note the spillage test requirements detailed further on in this manual. If the fan is likely to affect the appliance, the appliance must not be installed unless the fan is permanently disconnected.

Location.

– This appliance must not be installed in a private garage or any room, which contains a bath, or shower or where steam is regularly present.

Propane gas.

– Propane gas appliances must not be installed in a cellar, basement or other room which is built entirely below ground level
(See Gas Safety (Installation and use) Regulations).

Gas connection.

– A nut and olive are provided for an 8mm pipe inlet connection to the elbow at the bottom front of the appliance. The elbow can be rotated to allow a connection from any direction. The elbow includes a valve for isolating the gas supply.

– The supply pipe must be rigid material. Flexible pipe must not be used.

– **Note: Prior to connecting the gas supply it is advisable to blow out the gas supply so that any dirt which may be present in the pipe is cleared and cannot enter the gas valve or pilot burner and so cause a blockage**

– With the supply connected pressure check the installation pipework for gas soundness. In the United Kingdom check in accordance with the current edition of BS6891. In the Republic of Ireland check in accordance with the rules in force.

Securing the stove.

The stove is supplied with two wood screws and wall plugs. Secure the stove in place through the holes in the rear feet.

INSTALLER GUIDE

Fitting the ceramic fuel effect.

The installer and owner guide for the ceramic fuel effect is supplied with the ceramic fuel effect. It is important that the installer guide for the ceramic fuel effect be placed inside or attached to this guide and handed to the customer following completion of the 'Final review' section.

6. OPERATING THE STOVE

Pre-lighting checks.

- Ensure all the building work and flue sealing is complete.
- Ensure the down draught deflector plate is fitted correctly.
- Ensure all the ceramic fuel effect pieces are correctly placed.
- Ensure that the stove door is closed and secured. Lock the stove door with the locking bolt.
- Ensure that the stove door is completely sealed.

Lighting the burner.

- If closed, open the isolating valve at the inlet elbow.
- Depress the control knob and rotate it SLOWLY anticlockwise to the pilot ignition position. A 'click' will be heard as the integral piezo operates.
- Turn the control knob clockwise to the 'Off' position. Repeat this operation until a flame appears at the pilot. The pilot can be seen by looking through the space in the left hand front of the fuel effect (See figure 8). There may be a delay before the pilot lights due to air being purged from the system. When a flame appears at the pilot keep the control knob depressed and hold the pilot ignition position for five seconds. When the control knob is released the pilot flame should remain lit.

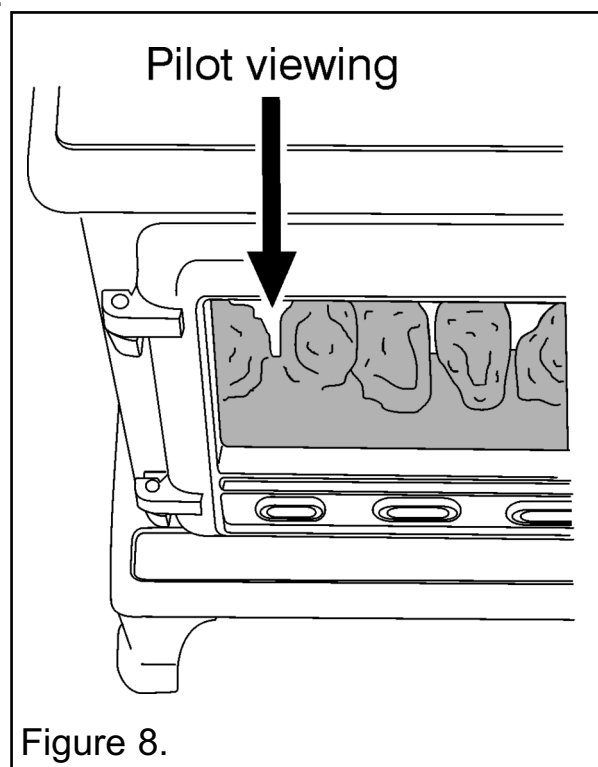

Figure 8.

Operating the burner.

- When the pilot burner is operating properly, gradually turn the control knob anticlockwise to 'HIGH' (Depress the knob slightly to get past the pilot ignition position). The main burner should now light. Depress the control knob slightly to release from the 'HIGH' position and turn back (clockwise) to 'LOW'. While turning, the burner flames should gradually become lower but remain alight. Depress the control knob slightly to release from the 'LOW' position and turn back (clockwise) to the 'Pilot ignition' position. The main burner should extinguish but the pilot should remain alight.

INSTALLER GUIDE

Depress the control knob slightly and turn back (clockwise) to turn OFF. This will extinguish the pilot.

Inlet pressure check.

The appliance is pre-set to give the correct heat input at the inlet pressure shown in section 2 of this manual. No adjustment is necessary.

– Check the inlet pressure by fitting a pressure gauge at the test point. The test point is on the inlet ‘T’ connector (See figure 9). Check the pressure with the appliance alight and set at maximum output.

– After checking, turn off the appliance.

Remove the pressure gauge and replace the test point sealing screw.

– Relight the appliance. Turn to the maximum output position and test around the sealing screw for gas soundness with a suitable leak detection fluid.

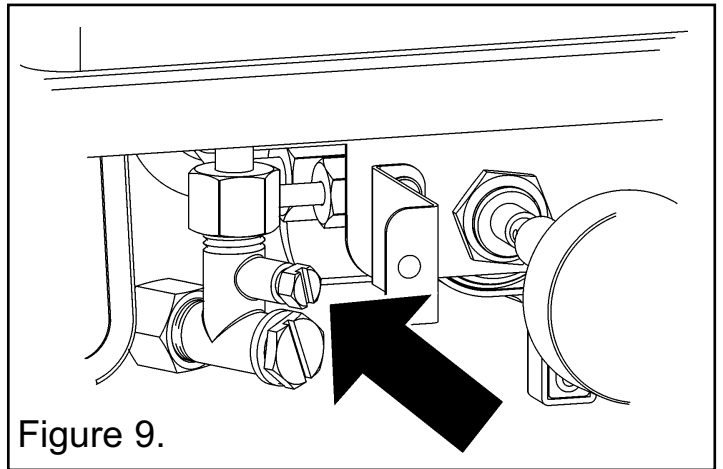

Figure 9.

Check for spillage.

– Close all doors and windows in the room containing the appliance.

– Light the appliance and turn the control knob to the ‘HIGH’ position.

– Leave the appliance on for five minutes.

– A smoke match should be placed close to base of the diverter box. The installation is satisfactory if the smoke is drawn into the appliance/ flue way. Do not use a lighted match or a naked flame.

If the smoke is not drawn into the appliance leave the appliance alight at the maximum setting for a further ten minutes and then repeat the test. If the flue restrictor is fitted then remove the restrictor and repeat the above test. If the smoke is still not drawn into the appliance then **disconnect the appliance and seek expert advice.**

– If the above test is satisfactory open all internal connecting doors, hatches, etc. in the room. Keep all doors and windows that open to the outside of the building closed. Recheck for spillage as above. If an extractor fan is installed in the same room as the appliance or a connecting room, check that spillage does not occur with the fan operating and all doors and other openings between the fan and the appliance open. If the smoke is drawn into the appliance, continue with the installation. If the test is not satisfactory **disconnect the appliance and advise the customer of the cause of failure.**

Flame supervision and spillage monitoring system.

The pilot unit incorporates a system that will automatically shut off the gas supply if the pilot flame goes out. Check that the system operates properly as follows;

INSTALLER GUIDE

- Light the appliance. Set at the “HIGH” position and leave for one minute.
 - Turn back to “OFF” to extinguish the pilot. **Note the time when the pilot goes out.** Listen for a snap sound at the gas tap. **Note the time when the sound is heard.** This sound is caused by an electromagnetic valve shutting off the gas supply through the tap. The valve is located in the body of the tap. The valve should operate **within 60 seconds of the pilot going out.** If the valve does not operate within this time limit do not allow the appliance to be used until the fault has been corrected.
- This monitoring system must not be adjusted, bypassed or put out of operation.**
- This monitoring system, or any of its parts, must only be exchanged using Valor Fires authorised parts.**

7. FINAL REVIEW AND SERVICING

Final Review.

- Hand the literature pack with this guide to the customer.
 - Visually inspect the appliance. Clean off any marks incurred during installation.
 - Advise the customer how to operate the appliance. Point out that lighting instruction details are on the metal plate attached to the burner at the bottom of the appliance.
 - Explain to the customer that the appliance has a flame failure & spillage monitoring system. Point out the explanation of this system shown in the owner guide under “Operating your stove”. Advise that if the stove goes out for any reason, wait at least ten minutes before relighting. Stress that if the monitoring system repeatedly shuts off the stove, the appliance should be switched off and a specialist should be consulted.
 - Advise the customer that they should read their owner guide before operating the stove and always follow the advice in the section headed “Cleaning your stove”.
 - **Stress that no extra ceramic fuel effect pieces must be added over and above those supplied with the appliance and that any replacements must only be the authorised spares. Warn that ignoring this advice could cause incomplete clearance of the products of combustion with consequent health hazards.**
 - Advise the customer that the appliance will operate to its maximum potential if the flue is primed during the first 20 – 30 minutes of use. To do this, simply turn the control knob to its highest setting. This will also burn off any carbon deposits that may have formed during previous use.
- If using the appliance for long periods it is beneficial to change between settings. This will also help to remove any carbon deposits that may form during use.
- Recommend that the appliance should be serviced by a competent person at least annually.
 - If the appliance is in premises in the United Kingdom occupied by a tenant, point out that by law a landlord must have any gas appliance, flue and pipework which is situated in a tenant’s premises checked for safety at least every 12 months.
 - Explain to the customer that when operating the stove for the first time, some vapours may be given off which may cause a slight odour and could possibly set off

INSTALLER GUIDE

any smoke alarms in the immediate vicinity. These vapours are quite normal with new appliances. They are totally harmless and will disappear after approximately twelve hours use.

– **Inform the customer that the Serial number for the appliance is located on the metal plate attached to the burner at the bottom of the appliance underneath the burner module.**

Servicing.

– **This product uses fuel effect pieces containing Refractory Ceramic Fibres (RCF), which are man-made vitreous silicate fibres. Excessive exposure to these materials may cause irritation to eyes, skin and respiratory tract. Consequently, it is important to take care when handling these articles to ensure that the release of dust is kept to a minimum. To ensure that the release of fibres from these RCF articles is kept to a minimum, during installation and servicing we recommend that you use a HEPA filtered vacuum to remove any dust and soot accumulated in and around the stove before and after working on the stove. When replacing these articles we recommend that the replaced items are not broken up, but are sealed within a heavy duty polythene bag, clearly labelled as RCF waste. RCF waste is classed as a stable, non-reactive hazardous waste and may be disposed at a landfill licensed to accept such waste. Protective clothing is not required when handling these articles, but we recommend you follow the normal hygiene rules of not smoking, eating or drinking in the work area and always wash your hands before eating or drinking. This appliance does not contain any component manufactured from asbestos or asbestos related products.**

– Always turn off the gas supply and allow to cool completely before commencing any servicing.

– Check that the thermal switch is correctly located in the diverter box (See figure 4 on page 10).

– Check that the appliance is clean and that no matter is blocking the burner or pilot which may cause imperfect flames or prevent a correct electrode spark.

– After servicing, make sure that the ceramic fuel effect pieces are replaced correctly as described in the installer and owner guide supplied with the ceramic fuel effect. The ceramic fuel effect guide may have been placed inside or attached to this guide.

– **Always test for gas soundness and spillage after servicing the appliance.**

INSTALLER GUIDE

Checking the aeration setting of the burner.

(For LPG models refer to the conversion guide).

– The aeration shutter is factory set. It is important to ensure that the aeration setting is correct. Check the aeration shutter setting (See figure 10).

– To adjust the aeration setting, loosen the two aeration shutter screws, slide the aeration shutter to the position shown in figure 10 and tighten the fixing screws.

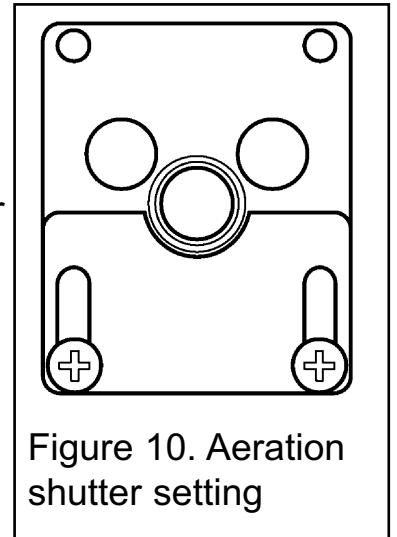

OWNER GUIDE

OWNER GUIDE

LIST OF CONTENTS

<u>Heading</u>	<u>Page</u>
SAFETY	21
OPERATING YOUR STOVE	23
The Flame Sensing & Flue Blockage Safety System.	23
Lighting the burner.	23
Operating the burner.	24
GAS CONSUMPTION	24
CLEANING YOUR STOVE	25
Cast Iron Surfaces.	25
Opening the Door.	25
The Glass Window.	25
FITTING THE CERAMIC FUEL EFFECT	25
MAINTENANCE AND SERVICING	26 - 30
Regular maintenance.	
Servicing.	
Standard Warranty and terms.	

This appliance has been designed to meet the most stringent quality, performance and safety requirements to provide our customers with many years' trouble-free service. Your owner guide aims to improve your understanding and appreciation of your gas stove by providing simple and informative instructions to ensure that you benefit from the excellent performance and features it has to offer.

OWNER GUIDE

SAFETY

IF YOU SMELL GAS

- **DON'T SMOKE.**
- **EXTINGUISH ALL NAKED FLAMES.**
- **DON'T TURN ELECTRICAL SWITCHES ON OR OFF.**
- **TURN OFF THE GAS SUPPLY AT THE METER OR TANK AS APPROPRIATE.**
- **OPEN DOORS AND WINDOWS TO GET RID OF THE GAS.**
- **IMMEDIATELY CALL THE GAS EMERGENCY SERVICE FROM A NEIGHBOURS PHONE - SEE YOUR LOCAL TELEPHONE DIRECTORY.**

Do have the gas stove installed by a competent person. In the United Kingdom, installation must be in accordance with the latest edition of the Gas Safety (installation & use) Regulations. In the Republic of Ireland, installation must be in accordance with all national and local regulations in force.

Do have the chimney swept prior to installation if it was previously used for solid fuel.
Do have the gas stove installed in accordance with the installation instructions. On no account must the stove stand on carpets or other combustible materials. The stove must stand on a non-combustible hearth surface. The hearth material must be at least 12mm (1/2") thick and should protrude at least 150mm (6") in front of the stove body.

Do provide the minimum clearances shown in figure 1.

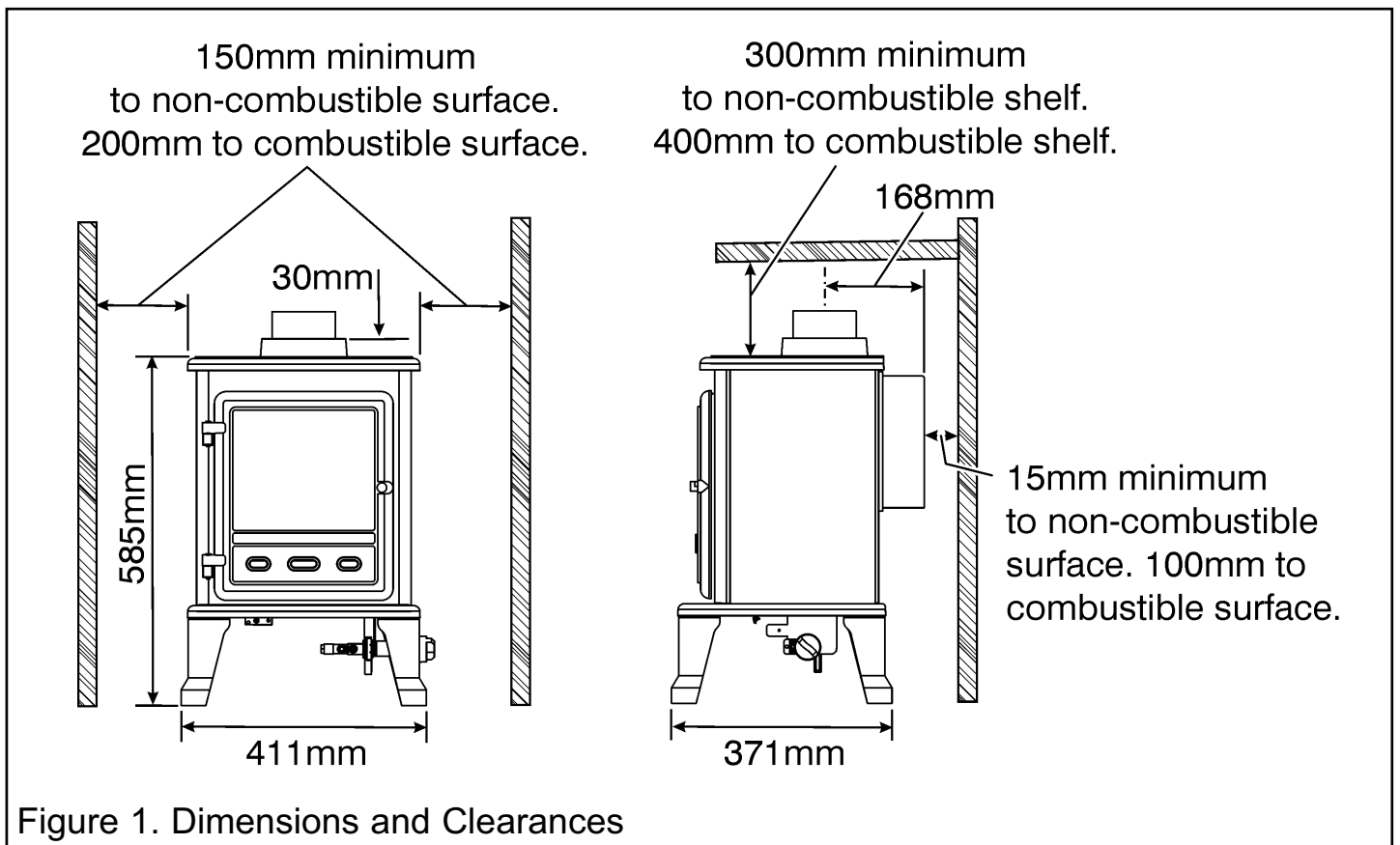

Figure 1. Dimensions and Clearances

OWNER GUIDE

Do always use a fireguard complying with BS 8423 for the protection of young children, the elderly, the infirm or pet animals. The cast iron top, front, rear and sides of this stove are considered to be working surfaces and so will become very hot when in use. Always take care when using this appliance.

Do wait three minutes before attempting to relight if the gas stove is switched off or the flames are extinguished for any reason (Your gas stove is fitted with a safety device that will automatically shut off the gas supply to the gas stove, if for any reason, the flame goes out. If this operates then wait at least ten minutes before operating the stove).

Do get advice about the suitability of any wall covering near your gas stove. Soft wall coverings (e.g. embossed vinyl, etc.) which have a raised pattern are easily affected by heat. They may, therefore, scorch or become discoloured when close to a heating appliance. Please bear this in mind whenever you are considering redecorating.

Don't use this stove with the door open or with the glass panel damaged or removed. The door should always be secured with the locking screw (See "Cleaning your stove"). If the window is damaged or will not close securely the stove must be turned off and not used until the window is changed or corrected by a competent service engineer.

Don't hang clothing, towels or any other fabrics over the gas stove.

Don't put more loose ceramic fuel effect pieces on the gas stove than the number given in the guide supplied with the ceramic fuel effect. This may have been attached to or placed inside this guide. Never use any ceramic fuel effect other than those authorised for this gas stove. Incorrect combustion and subsequent health hazard could result.

Don't put paper or other materials into your gas stove.

Don't use the gas stove with damaged base ceramics.

Don't place any combustible material (rugs, carpet, plastic tiles, etc.) on the hearth.

Don't attempt to clean or service the gas stove until it has been switched off and allowed to cool completely.

Don't leave the stove on if the house is left unoccupied for a long period. We recommend that the stove is turned fully off.

OWNER GUIDE

OPERATING YOUR STOVE

PLEASE NOTE

When operating your stove for the first time, some vapours may be given off which may cause a slight odour and could possibly set off any smoke alarms in the immediate vicinity. These vapours are quite normal with new appliances. They are totally harmless and will disappear after approximately twelve hours use.

This stove is supplied with ceramic fuel effect to simulate a real stove. After some use, these may change colour. This is quite normal.

The Flame Sensing & Flue Blockage Safety System.

For your safety, this appliance is fitted with a flue blockage safety device that will shut down the appliance in the event of abnormal flue conditions. **This device is NOT a substitute for an independently mounted Carbon Monoxide detector.**

The device will also automatically shut off the gas supply to the gas stove if the pilot flame goes out for any reason. **If the device starts to shut off the gas frequently, get expert advice.**

The system incorporates a probe that senses that the heat from the pilot flame is correct. If this probe is cool, the device will prevent any gas flow unless the control knob is kept depressed at the PILOT/IGN position.

If the safety system operates and the flames go out **wait at least ten minutes before attempting to relight.**

Always make sure that the door is securely closed before lighting.

If the gas valve is operated to turn the stove off always **wait at least three minutes before attempting to relight.**

Always make sure that the door is securely closed before lighting.

Lighting the burner.

– Depress the control knob and rotate it anticlockwise to the pilot ignition position (See figure 2). A 'click' will be heard as the integral piezo operates. A flame should appear at the pilot. Keep the control knob depressed and hold the pilot ignition position for five seconds. When the control knob is released the pilot flame should remain lit. If a flame does not appear at the pilot then turn the control knob clockwise to the 'OFF' position and repeat the above.

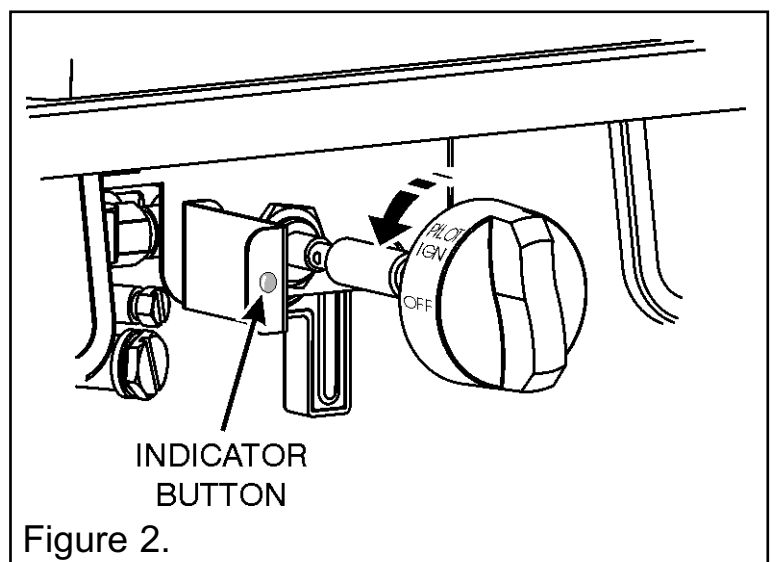

Figure 2.

OWNER GUIDE

Operating the burner.

– When the pilot burner is operating properly, gradually turn the control knob anti-clockwise to 'HIGH' position. (Depress the knob slightly to get past the pilot ignition position). The main burner should now light.

Depress the control knob slightly to release from the 'HIGH' position and turn back (clockwise) to 'LOW'. While turning, the burner flames should gradually become lower but remain alight. Depress the control knob slightly to release from the 'LOW' position and turn back (clockwise) to the Pilot ignition position. The main burner should extinguish but the pilot should remain alight. Depress the control knob slightly and turn back (clockwise) to turn OFF. This will extinguish the pilot.

While cooling, the ceramic fuel effects may make some crackling noises. This is quite normal.

- Note
- i) If the flames go out while setting the control, repeat the full lighting procedure. If the flames repeatedly go out have the stove serviced.
 - ii) Please note. When first turned on the flames will appear predominantly blue. The fuel effect pieces will take time to warm up. Although some glow will be seen after approximately ten minutes, the full visual effect will only be apparent after a somewhat longer time.
 - iii) The appliance will operate to its maximum potential if the flue is primed during the first 20 – 30 minutes of operation. To do this, simply slide the control button to its highest setting. This will also burn off any carbon deposits that may have formed during previous operations.
 - iv) If operating the appliance for long periods it is beneficial occasionally to change the settings. This will also help to remove any carbon deposits that may form during operation.

GAS CONSUMPTION

Model 910

Has a maximum natural gas input of 5.50kW (Gross)

Has a maximum natural gas output of 4.02kW

Has a minimum natural gas input of 2.3kW (Gross)

Has a minimum natural gas output of 1.68kW

Model 910 when converted using kit number 0591011

Has a maximum propane gas input of 5.40kW (Gross)

Has a maximum propane gas output of 3.94kW

Has a minimum propane gas input of 3.8kW (Gross)

Has a minimum propane gas output of 2.77kW

OWNER GUIDE

CLEANING YOUR STOVE

Turn the stove off and allow it to cool completely before attempting any cleaning. Note that it will retain heat for some time after it has been turned off.

Cast Iron Surfaces.

Regular dusting with a dry lint free cloth is all that should normally be necessary. If the paint needs retouching, allow the stove to cool completely. Brush any areas needing attention with a wire brush (Not enamelled surfaces). Clean off any loose matter. Touch up with high temperature stove paint. Apply the paint sparingly. Two light coats are better than one thick coat.

Opening the Door.

The door is secured with a locking bolt and Hex nut. To open the door use a 3mm Allen key to loosen the hex nut on the side of the door, being careful not to remove it completely. Ref to Figure A. Then select a suitably sized spanner and turn counter clockwise by approximately a quarter turn on the handle to open.

Always secure the door with the locking bolt and hex nut to prevent inadvertent opening and consequent injury or damage while the stove is in use. To lock the door turn the locking bolt first clockwise followed by the hex nut until they reach their stopping points.

The Glass Window.

Any stains on the glass can be removed with a non-abrasive cleaner such as a ceramic hob cleaner. **Never use abrasive cleaners.** Clean the window carefully in accordance with the instructions supplied with the cleaner.

FITTING THE CERAMIC FUEL EFFECT

The installer and owner guide for the ceramic fuel effect is separate from this guide. The installer may have attached it to this guide or placed it inside. It is important that the installer and owner guide for the ceramic fuel effect is followed correctly. If replacing the ceramic fuel effect, where a new guide is supplied, follow the installer and owner guide supplied with the replacement fuel effect.

Keep the replacement installer and owner guide with this owner guide for future reference.

Regular maintenance.

In order to achieve and maintain high levels of personal safety and performance efficiency, it is essential that the flue is kept clear of any form of obstruction.

In the United Kingdom it is the law that a landlord must have any gas appliance, flue and pipework which is situated in a tenant's premises checked for safety at least every twelve months by a competent person (In the UK a GAS SAFE REGISTER engineer, Outside of the UK a CORGI or GAS SAFE REGISTER engineer).

We recommend that all gas appliances and their flues, wherever situated, are checked annually.

OWNER GUIDE

WARRANTY AND SERVICE

Standard Warranty Terms & Conditions

The warranty is for 12 months subject to contract.

In the United Kingdom servicing can be carried out either by a **GDC** service engineer or a **GAS SAFE REGISTER** engineer. Outside of the United Kingdom servicing can be carried out either by a **CORGI** or **GAS SAFE REGISTER** engineer.

You must register your fire with by calling our telephone registration line on **08444 810 214**.

It is also a requirement of the warranty that the fire has an annual service (every 12 months) in accordance with the installation and servicing instructions, performed by a **GAS SAFE REGISTER** engineer, (**CORGI** or **GAS SAFE REGISTER** outside of UK)

Our promise to you

If you experience a fault with your new Gas Stove, we aim to provide a safe and high quality repair service supported by our dedicated national network of highly skilled engineers. If your installer can't resolve the problem for you, we will do everything we can to get an engineer out to you as quickly as possible. Nothing in this warranty will affect your statutory rights.

What you need to do if you experience a problem with the operation of the fire:

- You should always contact your installer first, because the cause of the fault may not be related to the fire.
- If your installer confirms that the fault is with the fire and they can't repair it, our friendly customer service team is on hand to help.
- Simply call our UK GDC Helpline on **0844 879 35 88** or from the Republic of Ireland call **01 842 8222** for any general advice that you may need.

OWNER GUIDE

When calling the **GDC Helpline**, it would be helpful if you could have the following information to hand:-

1. Stove serial number
(The serial number can be found on the Burner unit serial number label).*
2. Date of installation.*
3. Your installer name and address details.*
4. Stove make/name and burner unit model number.*
5. Proof of purchase (if you do not have the fire serial number).

***Note: Details 1 – 4 should be recorded on pages 29 & 30 at the end of this guide.**

What this warranty covers

Free of charge repair or replacement of components found to be of faulty manufacture.

Free of charge replacement of the complete unit providing the failure is related to a manufacturing fault that cannot be repaired or is uneconomic to repair.

What this warranty does not cover

Repairs to the Stove or Burner unit which haven't been installed and commissioned properly and as set out in the installation instructions.

Faults caused by inadequate supply of gas or electricity (where applicable).

Reimbursement of any third party repair or replacement costs that we haven't been told about or agreed with you in advance.

Compensation or consequential losses (e.g. loss of earnings, business losses, stress and inconvenience) arising from a production breakdown, including repair delays caused by factors outside our reasonable control.

OWNER GUIDE

To be completed by installer:

Installer Details (Block Capitals)

Installer Name	
Gas Safe Register or Corgi Registration Number.	
Company Name.	
Company Address	
Company Telephone number	
Company Fax number	

OWNER GUIDE

Model

Serial number (Can be found on the Burner unit Serial number label)

A LABEL CONTAINING THE SERIAL NUMBER MAY HAVE BEEN PLACED INSIDE THE BURNER BOX. IF SO PLEASE STICK INTO THIS BOX FOR FUTURE REFERENCE.

Brand (Please tick)

Valor

Other.....

Date of Installation

D D M M Y Y