

onyx

Eclipse 60HL

CONVENTIONAL FLUE LOG EFFECT FIRE
with Thermostatic Remote Control



Instructions for Use, Installation & Servicing

IMPORTANT

THE OUTER CASING, FRONT AND GLASS PANEL BECOME EXTREMELY HOT DURING OPERATION AND WILL RESULT IN SERIOUS INJURY AND BURNS IF TOUCHED. IT IS THEREFORE RECOMMENDED THAT A FIREGUARD COMPLYING WITH BS 8423 (LATEST EDITION) IS USED IN THE PRESENCE OF YOUNG CHILDREN, THE ELDERLY OR INFIRM.

This product contains a Heat resistant glass panel. This panel should be checked during Installation and at each servicing interval. If any damage is observed on the glass panel (scratches, scores, cracks or other surface defects), the glass panel must be replaced and the appliance must not be used until a replacement is installed.

Under no circumstances should the appliance be used if any damage is observed, the glass panel is removed or broken.

It is essential that ALL of the screws that retain the glass frame are replaced and tightened correctly. Under no circumstances should the appliance be operated if any of these screws are loose or missing.

These Instructions must be left with the appliance for future reference and for consultation when servicing the appliance. Please make the customer aware of the correct operation of the appliance before leaving these instructions with them.

The commissioning sheet found on Page 3 of this Instruction manual must be completed by the Installer prior to leaving the premises



It is a requirement of the Building Regulations 2010 that the installation of this appliance is notified to the Local Authority. It is the responsibility of the GasSafe registered installer to carry out this notification to the Local Authority via the GasSafe register Competent Persons Scheme in England and Wales (different rules apply in Scotland and Northern Ireland).

When the installation has been notified, GasSafe will send a Building Regulations Compliance Certificate to you containing details of the work completed. Please ensure that the person responsible for the installation of this appliance completes this notification and records it in the Appliance Commissioning Checklist on page 3.

IT IS YOUR RESPONSIBILITY TO COMPLY WITH THE BUILDING REGULATIONS AND BE ABLE TO PRODUCE THIS CERTIFICATE SHOULD IT BE REQUIRED IN THE FUTURE.



In the event of a gas escape or if you can smell gas, please take the following steps:

- Immediately turn off the gas supply at the meter/emergency control valve

Extinguish all sources of ignition

- Do not smoke
- Do not operate any electrical light or power switches (On or Off)
- Ventilate the building(s) by opening doors and windows
- Ensure access to the premises can be made

Please report the incident immediately to the National Gas Emergency Service Call Centre on 0800 111 999 (England, Scotland and Wales) , 0800 002 001 (N. Ireland) or in the case of LPG, the gas supplier whose details can be found on the bulk storage vessel or cylinder.

The gas supply must not be used until remedial action has been taken to correct the defect and the installation has been recommissioned by a competent person.



APPLIANCE COMMISSIONING CHECKLIST

To assist us in any guarantee claim please complete the following information:-

IMPORTANT NOTICE

Explain the operation of the appliance to the end user, hand the completed instructions to them for safe keeping, as the information will be required when making any guaranteed claims.

FLUE CHECK	PASS	FAIL
1. Flue Is correct for appliance		
2. Flue flow Test		
3. Spillage Test		
GAS CHECK		
1. Gas soundness & let by test		
2. Standing gas pressure	mb	
3. Appliance working pressure (on High Setting) Minimum Pressure Requirement: NG - 17.5mbar LPG - 34.5mbar NB All other gas appliances must be operating on full	mb	
4. Gas rate	m ³ /h	
5. Does Ventilation meet appliance requirements?		
SAFETY CHECK		
1. Check soundness of the Thermocouple connections - including tightness and lead integrity		
2. Glass checked to ensure no damage, scratches, scores or cracks		
3. Glass frame secured correctly and all screws replaced		
4. CO Alarm Fitted		
BUILDING CONTROL NOTIFICATION	YES	NO
1. Installer notified GasSafe/Local Authority of installation via Competent Persons Scheme?		

RETAILER AND INSTALLER INFORMATION

Retailer

Installation Company

.....

.....

.....

.....

Contact No.....

Engineer.....

Date of Purchase

Contact No.....

Model No.

GasSafe Reg No.

Serial No.....

Date of Installation

Gas Type





ECLIPSE 60HL - CONVENTIONAL FLUE LOG EFFECT FIRE

NG	LPG
128-060	128-530

Contents

Appliance Commissioning Checklist	3
User Instructions	6
Installation Instructions	14
Site Requirements	18
Technical Specifications	17
Pre-Installation	20
Installation	24
Commissioning	40
Servicing Requirements	41
Fault Finding	41
How to replace parts	44
Spare parts list	55
Information Requirement - Gas Heaters	56



CONSUMER SUPPORT VIDEO:
www.onyxfires.com/support/eclipse60hl





Service that goes above and beyond

Congratulations on becoming a new owner of an Onyx stove or fire – welcome to the family. When you own an Onyx product, you can expect the very best in British stove and fire design and engineering, bringing exceptional heating performance to your home along with character and individuality.

We take great care to ensure that our stoves are designed, tested and manufactured to the highest possible quality standards, and pride ourselves on offering the same exemplary after-sales service that goes above and beyond, assuring you years of enjoyment from your Onyx purchase.



USER INSTRUCTIONS

GENERAL

Installation and servicing must only be carried out by a competent person whose name appears on the GasSafe register. To ensure the engineer is registered with GasSafe they should possess an ID Card carrying the following logo:



In all correspondence, please quote the appliance type and serial number, which can be found on the data badge located under the main burner with the gas valve or on the Commissioning Checklist on Page 3.

Do not place curtains above the appliance: You must have 300mm clearance between the appliance and any curtains at either side.

Parts of this appliance will become hot whilst in operation. A suitable guard is recommended to protect young children, the aged and the infirm.

No furnishings or other objects should be placed within 1 metre of the front of the appliance.

If a shelf is fitted, a distance of 225mm above the appliance is required.

Do not attempt to burn rubbish in this appliance.

This appliance must only be operated with the door secured firmly in position. If any cracks appear in the glass the appliance must not be used until the glass panel is replaced.

This product is guaranteed for 5 years from the date of installation, as set out in the terms and conditions of sale between Onyx and your local Onyx retailer. Please consult with your local Onyx retailer if you have any questions. In all correspondence always quote the Model Number and Serial Number.

OPERATING THE APPLIANCE



To activate the Remote Control it will be necessary to cradle the handset to unlock.

The green light will illuminate to show the handset is ready to use.

IMPORTANT: Continue to cradle the handset throughout an operation to keep it unlocked.

If the green light goes off during an operation it will be necessary to reposition the handset so the light comes back on and restart the operation.



Handset unlocked (when illuminated)

HANDSET FEATURES



The Icon at the bottom of the screen displays the battery condition of both the batteries in the handset and in the appliance alternatively.

RC = Remote Control Handset
FC = Fire Control (Appliance)



If the handset has been replaced or the fire has been serviced, see Installation Section to set up the handset.

MANUAL OPERATION (REMOTE CONTROL)



To activate the Remote Control it will be necessary to cradle the handset to unlock. The green light will illuminate to show the handset is ready to use.

IMPORTANT: Continue to cradle the handset throughout an operation to keep it unlocked. If the green light goes off during an operation it will be necessary to reposition the handset so the light comes back on and restart the operation.

TURNING THE APPLIANCE ON

Press the Power Button until Pilot flashes on the display.

Release the Power Button and the Flame symbol will appear on the display.

If the button is held the command will be cancelled for safety reasons.

Holding the handset to unlock, use + and - buttons to adjust the flame height between Minimum and Maximum.

TURNING THE APPLIANCE OFF

Holding the handset to unlock, press the power button to turn the appliance off.



IMPORTANT: YELLOW FLAMES TYPICALLY APPEAR WHEN THE APPLIANCE HAS REACHED NORMAL OPERATING TEMPERATURE. THIS CAN TAKE UP TO 30 MINUTES.



WARNING: IF THE APPLIANCE FAILS TO LIGHT OR BECOMES EXTINGUISHED IN USE, WAIT 3 MINUTES BEFORE ATTEMPTING TO RELIGHT.

THE APPLIANCE WILL TAKE 3 AUTOMATIC ATTEMPTS TO RESTART. DO NOT INTERRUPT THE VALVE DURING THIS PROCESS.

SETTING TIMER MODE (IN MANUAL OPERATION)

Timer Mode will turn the appliance off after a set period of time has elapsed.

Timer Mode can be set before or during manual operation of the fire.



Note: If Timer mode is activated and the fire is manually turned off, the timer will be cancelled. Changes to the Timer will reset to the default time on next use.

If the fire is off when the Timer mode is set then the timer will automatically start when the fire is turned on.

Hold the handset to unlock and press and release the MODE button. The word MAN and the Zzz symbols flash at the top of the display.

Press and release the SET button. This will activate the Timer mode.

The default time period is 1 hour, unless altered in Advanced Settings.

Pressing the SET button again will show the remaining time. This can be altered by pressing the + or - buttons. The timer can be set between 1 minute and 24 hours.

After adjusting the time press SET again to confirm the time setting desired.

Once the countdown has reached zero the fire will turn off.

THERMOSTATIC MODE

The handset contains a thermostatic sensor to control the operation of the appliance according to the temperature of the room.

There are 3 temperature options that can be set:

Day Mode - indicated by a Sun symbol on the display (default temperature 24°C)

Night Mode - indicated by a Moon symbol on the display (default temperature 18°C)

Frost Protection - indicated by a Snowflake symbol on the display (default temperature 5°C)

PROGRAMMING THE MODES

Holding the handset to unlock, press and hold the SET button until a beep is heard to indicate the command has been received.

Release the SET button. PROG and a flashing thermometer symbol will be displayed at the top of the display.

Press and release the SET button to enter Day Mode. The current temperature setting and mode will be displayed- for example the Sun symbol on the left shows it is in Day Mode and the default temperature is 24°C.

To change the temperature press + or - whilst the set temperature is displayed to alter the setting.

Press and release the SET button to confirm and to scroll to the Night Mode.

To change the temperature press + or - whilst the set temperature is displayed to alter the setting.

Press and release the SET button to confirm and to scroll to Frost Protection mode.

To change the temperature press + or - whilst the set temperature is displayed to alter the setting.

When finished press the SET button again and the new settings will be accepted.

The display will return to the time of day screen.

CHOOSING A MODE

When choosing a mode during operation the temperature can be temporarily changed, however these settings will reset to the previously set programmed settings when the fire is turned off.

Holding the handset to unlock, press and release the MODE button several times until a thermometer symbol flashes at the top of the display.

Press the SET button to enter the Thermostatic mode.

Press the Set button again to see the current temperature setting and mode - for example the a Sun symbol on the left shows it is Day Mode and the default temperature is 24°C.

With the temperature displayed, press + or - to alter the setting.

Press the MODE button repeatedly to scroll through the settings and to select Night mode or Frost Protection.

The handset must be left in the chosen mode for it to operate.

When finished press SET again and the new setting will be accepted. The display will return to the time of day screen.

If at any time the power button is operated during Thermostatic Mode the control will cancel any thermostat operation and return the handset to Manual Mode.

SETTING TIMER MODE (IN THERMOSTATIC OPERATION)

Timer Mode will turn the appliance off after a set period of time has elapsed. Timer Mode can be set before or during thermostatic operation of the fire.

Hold the handset to unlock, press and release the MODE button until the word MAN and the Zzz symbols are flashing at the top of the display.

Press and release the SET button. This will activate the Timer mode.

The default time period is 1 hour, unless altered in Advanced Settings.

Pressing the SET button again will show the remaining Time. This can be altered by pressing the + or - buttons. The timer can be set between 1 minute and 24 hours.

After adjusting the time press SET again to confirm the time setting desired.

Once the countdown has reached zero the fire will turn off.

Note: If Timer mode is activated and the fire is manually turned off, the timer will be cancelled. Changes to the Timer will reset to the default time on next use.

If the fire is off when the Timer mode is set then the timer will automatically start when the fire is turned on.

SETTING THE CLOCK

To adjust the time on the handset after initial set up:

Holding the remote to keep the green light on and the handset unlocked:

Press and hold the SET button until a beep is heard to indicate the command has been received.

Release the SET button. PROG will be displayed at the top left of the display.

Press the MODE button twice until SET UP flashes in the top right of the display.

Press and release the SET button. The handset will display an H:24.



24 denotes a 24 hour clock and 12 denotes a 12 hour clock.

Press the + or - button on the handset to toggle between the two settings. Press the SET button to confirm and progress to setting the day of the week.

SETTING THE DAY OF THE WEEK

Press and release the + and - buttons until the correct day of the week is shown on the display.



Mo = Monday, **Tu** = Tuesday, **We** = Wednesday, **Th** = Thursday, **Fr** = Friday, **Sa** = Saturday and **Su** = Sunday.

Press SET to confirm the day of the week and progress to setting the time.

SETTING THE HOUR

Press and release the + or - button to change the hour to the correct hour. Press SET to confirm and progress to setting the minute.



SETTING THE MINUTES

Repeat the process to change the minutes.

SETTING THE TEMPERATURE DISPLAY (CELSIUS OR FAHRENHEIT)

Press and release the + or - button to toggle between C and F. When the display shows the desired symbol, press and release the SET button to store.



To enter Advanced Settings, see below. To finish, place the handset down and wait until the home screen is displayed and the unlock light goes off.

! ALL THE NECESSARY SETTINGS REQUIRED HAVE NOW BEEN COMPLETED. ANY FURTHER FUNCTIONS ON THIS HANDSET ARE FOR FACTORY SETTING AND NOT TO BE USED.

The Handset is now ready to operate the appliance.

ADVANCED MENU SETTINGS

It is possible to change additional preset settings of the control features.

Access the Advanced Menu Settings. Press and release the SET button to enter the Advanced Settings Menu.

Advanced Settings are:

Back Light (L)

- A = Automatic (default setting).
The backlight comes on in the dark.
- O = Light never comes on.
- 1 = Light comes on when the handset is unlocked.

Display Contrast (C)

- 8 Levels from 0 - 7 (Default level 4).

P = Pairing with devices other than the Control Box. This feature is not available on this appliance.



IMPORTANT: THE FURTHER FUNCTIONS ON THIS HANDSET ARE FOR FACTORY SETTING ONLY AND ARE NOT TO BE USED. PLACE THE HANDSET ON A FLAT SURFACE AND WAIT UNTIL THE HOME SCREEN IS DISPLAYED AND THE UNLOCK LIGHT TURNS OFF.

CHANGING THE DEFAULT TIMER MODE

It is possible to change the default time period for the Timer mode.

The default time period for Timer mode is factory set to 1 hour.

To change the default time:

Holding the remote to keep the green light on and the handset unlocked:

Press and hold the SET button until a beep is heard to indicate the command has been received.

Release the SET button. PROG will be displayed at the top left of the display.

Repeatedly press the MODE button until the Zzz symbol flashes at the top of the display.

Press and release the SET button.

Press the + or - buttons to alter the default time period. The timer can be set between 1 minute and 24 hours.

After adjusting the time press SET again to confirm.

Note: This does not activate the Timer mode, see Installation Section, Manual Operation or Thermostatic Mode.

REPLACING THE APPLIANCE BATTERIES

Replace batteries at least every 12 months during the annual service of the fire.

i It is essential to use high quality batteries (Duracell or equivalent) when replacing batteries.

The icon at the bottom shows the battery condition of both the batteries in the handset and in the Control Box alternately.



RC = Remote Control Handset
FC = Fire Control (Appliance)

i **Note:** Change the batteries in the handset before they are flat, to avoid having to reprogram the time of day in again. N.B. Pairing is not lost, even if the batteries are removed or flat.

The appliance Control Box requires 3 AA size alkaline batteries.

The handset requires 2 AA size alkaline batteries.

The Control Box Battery Holder is located in the decorative lower trim.

BATTERY HOLDER

Remove the 2 side trims.
These are held on by magnets.

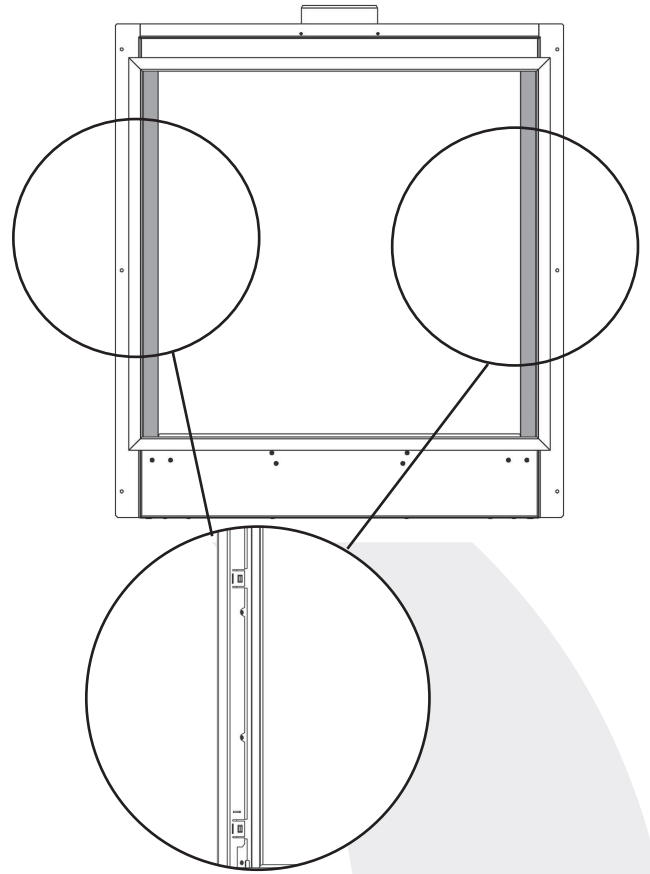

1

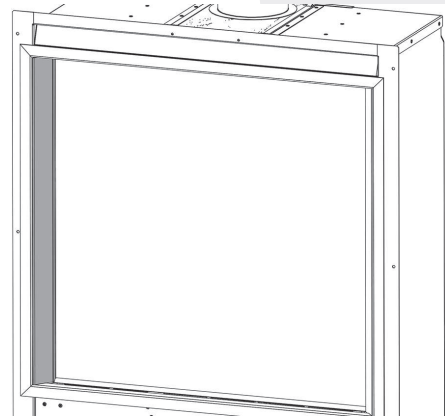

2

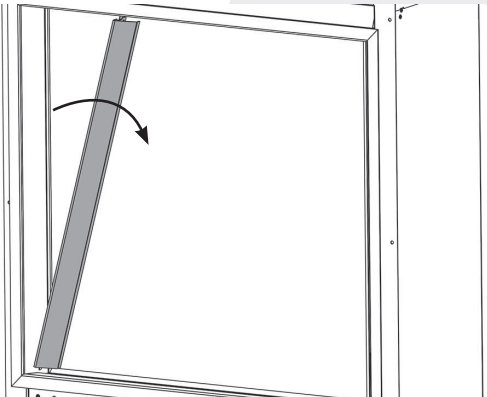

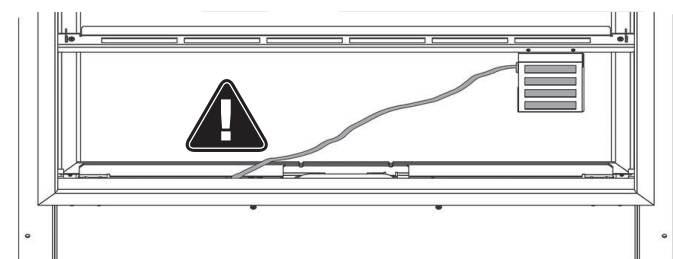
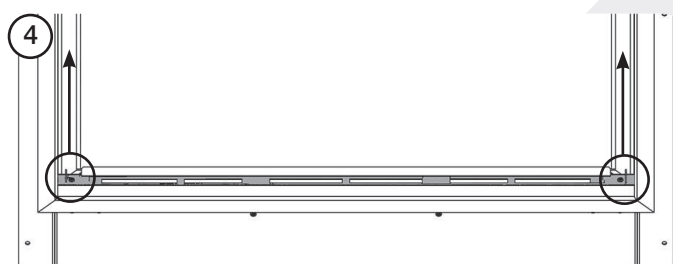
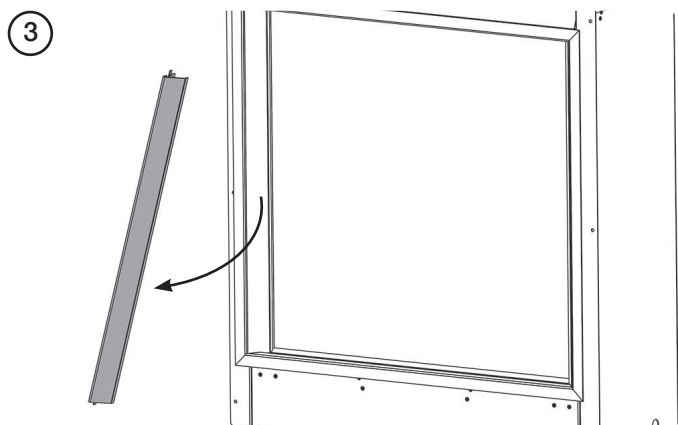

i The Battery Box cannot be disconnected from the Gas Valve at this stage.
DO NOT STRETCH THE WIRE.

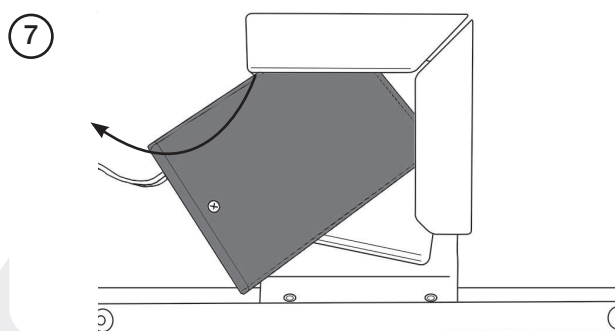
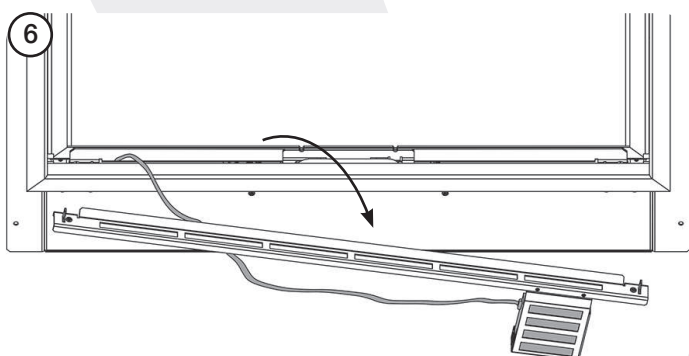
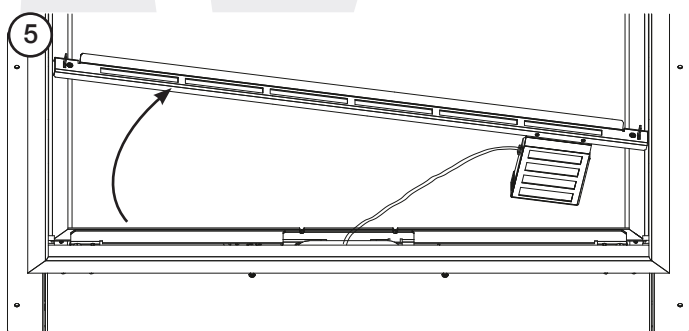

REPLACING THE BATTERIES

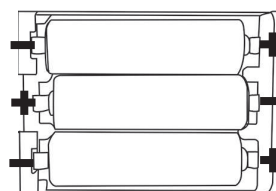
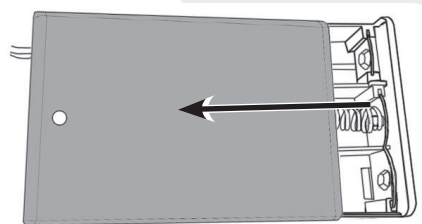
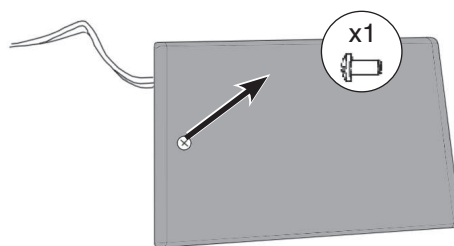

REMOTE CONTROL

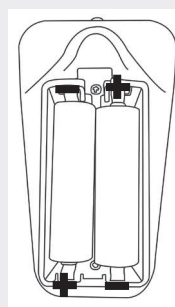
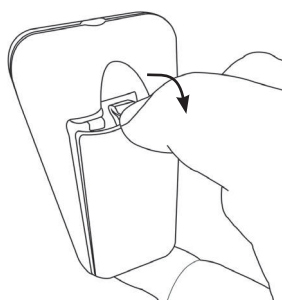

i If the appliance is left unattended for long periods of time (e.g. vacation), it is recommended to remove the batteries from the appliance.

OXYGEN DEPLETION SENSOR

The appliance is fitted with an oxygen sensitive pilot system that will act to cut off the gas supply to the appliance should the oxygen in the room fall below its normal level. If the appliance is turned off by this device, it usually indicates that there is a problem with the flue system, and this should be inspected by a qualified engineer.

If the handset displays the error code E01, higher levels of CO has been detected in the ambient atmosphere.

Do not attempt to use the appliance until an engineer says it is safe to do so.

This device is not a substitute for an independently mounted carbon monoxide detector.

FLAME FAILURE DEVICE

This is a safety feature incorporated on this appliance which automatically switches off the gas supply if the pilot goes out and fails to heat the thermocouple.

IF THIS OCCURS DO NOT ATTEMPT TO RELIGHT THE APPLIANCE FOR 3 MINUTES.



WARNING: IF THE APPLIANCE FAILS TO LIGHT OR BECOMES EXTINGUISHED IN USE, WAIT 3 MINUTES BEFORE ATTEMPTING TO RELIGHT.

THE APPLIANCE WILL TAKE 3 AUTOMATIC ATTEMPTS TO RESTART. DO NOT INTERRUPT THE VALVE DURING THIS PROCESS.

RUNNING IN

During initial use of a new Onyx appliance a strong odour will be encountered as various surface coatings become hot for the first time. Although these odours are harmless it is recommended that the appliance is operated on maximum for 4 to 8 hours in order to fully burn off these coatings. After this period the odours should then disappear.

If the odours persists, please contact your installer for advice.

During the first few hours of burning there may be discolouration of the flames. This will also disappear after a short period of use.

PILOT AREA WHITENING

Gas fire owners (not exclusive to Onyx) have reported issues of whitening around the pilot areas on their Conventional Flue glass fronted products. These white marks can also appear on glass or enamel panels inside the fire and on the inside of the glass.

The cause of this has been identified as Silica Dioxide. Silica Dioxide can be widely found in domestic cleaning products, cosmetics, scented room diffusers and candles.

SERVICING AND SUPPORT



Servicing and Support

To keep your appliance looking and performing at its best, it must be serviced annually. This service must be undertaken by a suitably qualified individual and your retailer can organise this for you. Alternatively, Onyx offer a manufacturers premium service with our friendly team of qualified engineers which can be booked at www.onyxfires.com/support

In all correspondence always quote the Model number and the Serial number which may be found on the Commissioning Checklist (Page 3).

VENTILATION

This appliance requires no additional ventilation.

INSTALLATION DETAILS

Your installer should have completed the commissioning sheet at the front of this book. This records the essential installation details of the appliance. In all correspondence always quote the Model number and Serial number.

HOT SURFACES

Parts of this appliance become hot during normal use. The shaded areas in the diagram are considered 'working surfaces'.

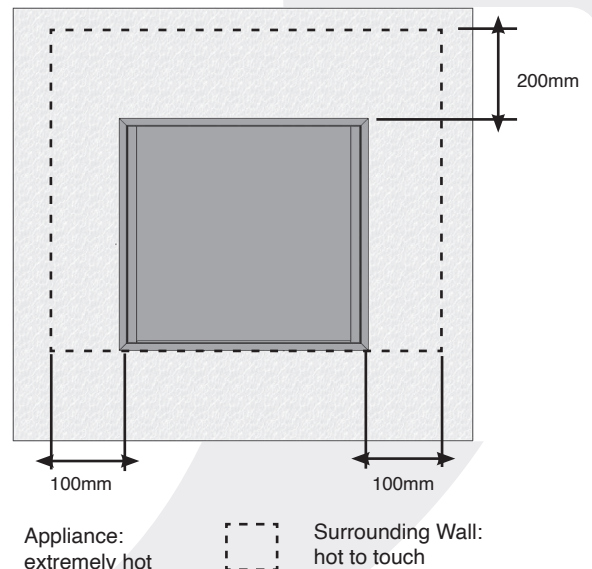

Provide a suitable fire guard to protect young children, the elderly and infirm.

APPLIANCE WILL NOT LIGHT

If you cannot light the appliance:

Check and change the batteries in the remote handset and appliance.

Consult your Onyx retailer or installer if the appliance still does not light.

SEASONAL USE

If the appliance is left unattended for long periods of time (e.g. vacation), it is recommended to remove the batteries from the appliance.

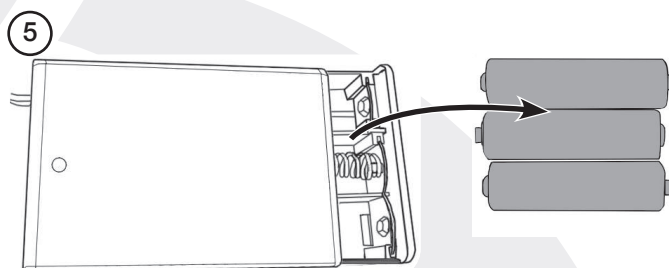
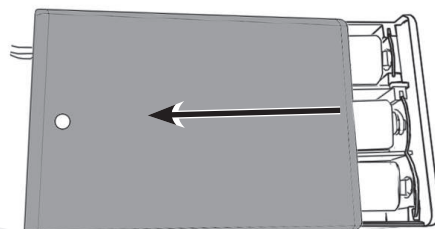
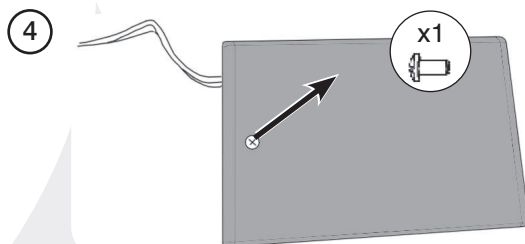
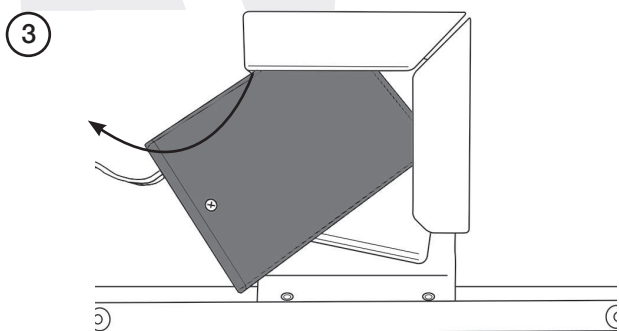
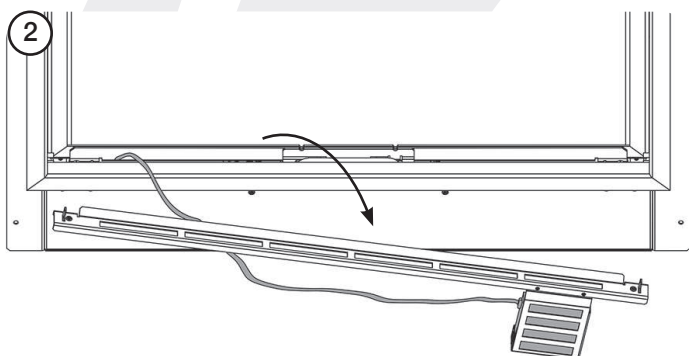
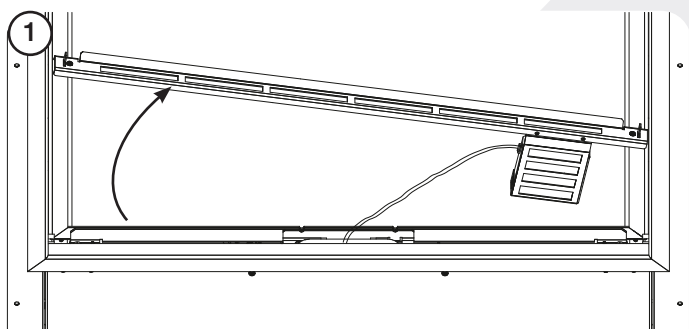

CO ALARMS

Building regulations require that whenever a new or replacement fixed gas burning appliance is installed in a dwelling, a carbon monoxide alarm complying with BS EN 50291-1 (latest edition) must be fitted in the same room as the appliance. Further guidance and recommendations on the installation of carbon monoxide alarms is available in BS EN 50292 (latest edition) and from manufacturers' instructions.

Provision of an alarm must not be considered a substitute for either installing the appliance correctly or ensuring regular servicing and maintenance of the appliance.

INSTALLATION

APPLIANCE LOCATION

This appliance can be installed in four different ways:

- 1) Builder's opening with an Edge finish.
- 2) Builder's opening with a decorative front.
- 3) Stud work with an Edge finish.
- 4) Stud work with a decorative front.

This appliance must not be installed in a room that contains a bath or shower.

Combustible parts of the studwork must not be any closer than the minimum dimensions shown in the diagrams. NOTE: These dimensions must be maintained even if the combustible materials is protected by non-combustible linings.

Do not pack the void around or above the appliance with insulation materials such as mineral wool.

A removable access hatch must be left in the side of the chimney breast for future servicing and inspection of the appliance.

Build the studwork chimney breast to the desired size. Ensure that the clearances to combustible materials is maintained.

SAFETY PRECAUTIONS

For your own and other's safety, you must install this appliance according to local and national codes of practice. Failure to install the appliance correctly could lead to prosecution. **Read these instructions before installing and using this appliance.**

These instructions must be left intact with the user.

Do not attempt to burn rubbish on this appliance.

Keep all plastic bags away from young children.

Do not place any object on or near to the appliance and allow adequate clearance above the appliance.

IF THE APPLIANCE IS EXTINGUISHED OR GOES OUT IN USE, WAIT 3 MINUTES BEFORE ATTEMPTING TO RELIGHT THE APPLIANCE.

The appliance is fitted with an oxygen sensitive pilot that will act to cut off the gas supply to the appliance in the event of incorrect operation of the flue.

If the system acts to shut off the gas supply, this indicates that there is insufficient flue pull. Continued operation of this safety device means that there may be a serious problem with the flue system, and this should be inspected by a qualified gas engineer. **Do not use the appliance until an engineer says it is safe to do so.**

The oxygen sensitive pilot must not be tampered with. Use only genuine Onyx replacement parts when servicing the appliance - refer to Servicing section.

There are three main suitable Conventional Flues:

- Top Exit - Builder's Opening Lined 127mm (5")
- Rear Exit - Builder's Opening Unlined 178mm (7") minimum
- Stud work is Top Exit only - Rigid Twin Wall Flue Pipe 127mm (5")



IMPORTANT: REFER TO DATA BADGE AND TECHNICAL SPECIFICATION AT THE FRONT OF THE MANUAL TO ENSURE THE APPLIANCE IS CORRECTLY ADJUSTED FOR THE GAS TYPE AND CATEGORY APPLICABLE IN THE COUNTRY OF USE.

UNPACKING

Remove the appliance from its packaging, and check that it is complete and undamaged.

Put the loose ceramic parts to one side so that they are not damaged during installation.

FLUE & CHIMNEY REQUIREMENTS

WHEN INSTALLING A FLUE SYSTEM PLEASE REFER TO THE MANUFACTURER'S INSTRUCTIONS.

The European chimney standards now describe chimneys and flues by their temperature, pressure and resistance to corrosion, condensation and fire. To identify the correct flue system, the minimum flue specification is shown in the Technical Specification. Existing chimneys are not covered by this system.

The flue must be installed in accordance with all local and national regulations and the current rules in force:

The chimney or flue system must comply with the rules in force, and must be 127mm (5") in diameter.

A flexible liner must be continuous from the appliance spigot to the roof terminal.

The minimum effective height of the flue must be 3m (10').

The flue must be free from any obstruction.

Any damper plates must be removed or secured in the fully open position and no restrictor plates fitted.

The chimney should be swept immediately before installing the appliance, but it need not be swept if you can see the chimney is clean and free from obstruction throughout.

TIMBER FRAMED BUILDINGS

It will be necessary to provide additional clearance when the flue passes through a wall containing any combustible materials so as to prevent a fire hazard.

The hole through which the flue will pass, must have a steel sleeve which is positioned so that an air gap of at least 25mm is maintained between the outer surface of the flue, and any part of the sleeve.

For further guidance on the installation of gas appliances in timber framed buildings, contact your local buildings control authority.

GAS SUPPLY

This appliance is intended for use on a gas installation with a governed meter.

Make sure local distribution conditions (identification of the type of gas and pressure) and the adjustment of the appliance are compatible before installation.

Ensure the gas supply delivers the required amount of gas and is in accordance with the rules in force.

Soft copper tubing can be used on the installation and soft soldered joints outside the appliance and below the firebed.

A factory fitted isolation device is part of the inlet connection; no further isolation device is required.

All supply gas pipes must be purged of any debris that may have entered prior to connection to the appliance.

The gas supply enters through the silicone panel located on the LEFT-HAND side on the rear of the outer box. Slit with a sharp knife prior to passing the supply pipe through.

The gas supply must be installed in a way that does not restrict the removal of the appliance for servicing and inspection.

VENTILATION

IMPORTANT: Ensure any national ventilation requirements are taken into account during installation of the appliance.

UK ONLY:

The appliance has a nominal input not exceeding 7.0kW net and does not normally require any additional permanent ventilation.

If however, spillage is detected when commissioning the appliance, there may be insufficient natural ventilation and additional ventilation may be required.

FOR THE REPUBLIC OF IRELAND REFER TO THE RULES IN FORCE FOR VENTILATION REQUIREMENTS.

CO ALARMS

Building regulations require that whenever a new or replacement fixed gas burning appliance is installed in a dwelling, a carbon monoxide alarm complying with BS EN 50291-1 (latest edition) must be fitted in the same room as the appliance. Further guidance and recommendations on the installation of carbon monoxide alarms is available in BS EN 50292 (latest edition) and from manufacturers' instructions.

Provision of an alarm must not be considered a substitute for either installing the appliance correctly or ensuring regular servicing and maintenance of the appliance.

DIMENSIONS

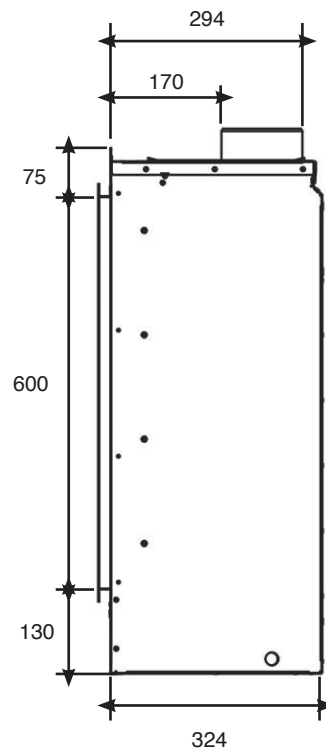
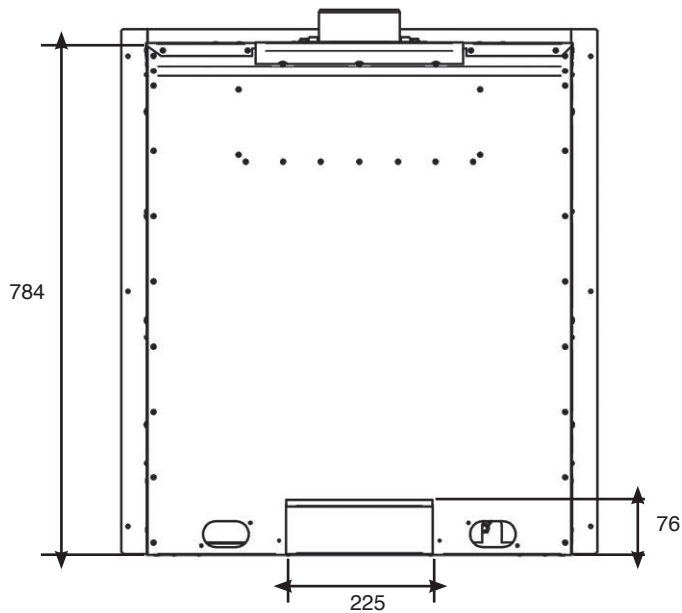
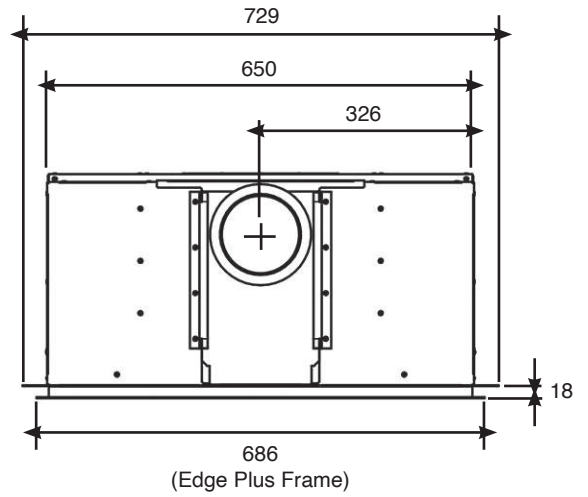
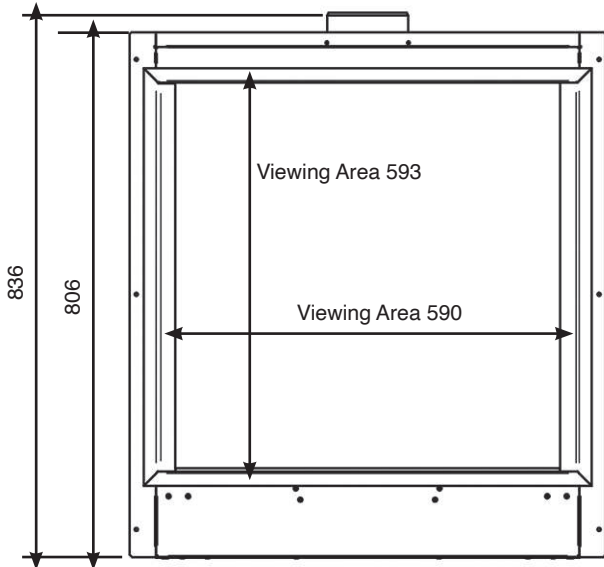

All dimensions in mm

TECHNICAL SPECIFICATION

Covering the following models:

NG	LPG
128-060	128-530

MODEL	GAS CAT.	GAS TYPE	WORKING PRESSURE	AERATION	INJECTOR	GAS RATE M ³ /H	INPUT KW (GROSS)		COUNTRY
							HIGH	LOW	
ECLIPSE 60HL CF	I _{2H}	Natural Gas G20	20mbar	Left - 2 x 5mm Right - 2 x 3mm Base - 2 x 2.5mm	Left - 150 Right - 102 Base - 117	0.695	7.3	5.1	GB, IE
	I ₃₊	Propane G31	37mbar	Left - 2 x 14mm Right - 2 x 14mm Base - 2 x 14mm	Left - 82 Right - 82 Base - 58	0.255	6.8	4.5	
		Butane G30	29mbar			0.195			
Efficiency Class 2 - 78% Net									
Flue Outlet Size TOP/REAR EXIT 127mm (5") ø									
Gas Inlet Connection Size 8mm ø									
Minimum flue specification T250 / N2 / O / D / 1									
Maximum flue temperature 240°C									

i The net efficiency of these appliances have been measured as specified in EN613:2001 and the result after conversion to gross using the appropriate factor from Table E4 of SAP 2012 is 70.2%. The test data has been certified by Kiwa Nederand BV. The gross efficiency value may be used in the UK Government's Standard Assessment Procedure (SAP) for energy rating of dwellings.

This appliance has been certified for use in countries other than those stated. To install this appliance in these countries, it is essential to obtain the translated instructions and in some cases the appliance will require modification. Contact Onyx for further information.

PACKING CHECKLIST

QTY DESCRIPTION	FIXING KIT CONTAINING:-
1 x Appliance	1 x Instruction manual
1 x Flue Blanking plate	1 x Embaglow
1 x Log set*	5 x AA Batteries
	1 x Foam Seal
*Packed in appliance	

INJECTOR TABLE

NAT GAS	150
LPG	82
NAT GAS	150
LPG	82

APPLIANCE LOCATION

Minimum opening dimensions:

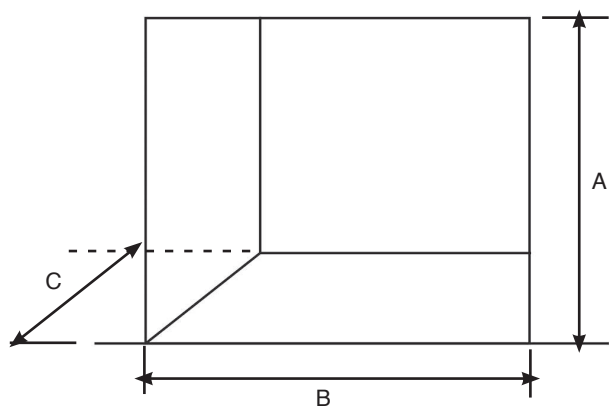

DIMENSION	ECLIPSE 60HL
A	790
B	674
C	422

This appliance must not be installed in a room that contains a bath or shower.

NOTE: If using natural materials for the back panel of the fireplace, it is recommended that it is constructed from three or more sections to prevent cracking. Resin-based materials may not be suitable. This appliance is an effective heat producer and attention must be paid to the construction and finish of the fireplace.

When the appliance is installed in a masonry chimney without a liner, there must be a minimum debris collection area.

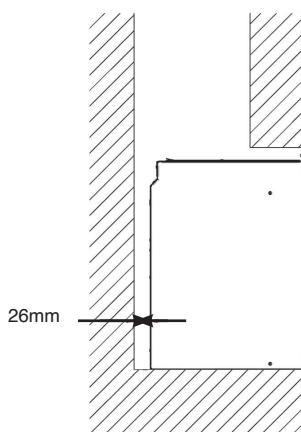

This appliance is not suitable for installation onto a combustible wall; all combustible materials must be removed from the area shown.

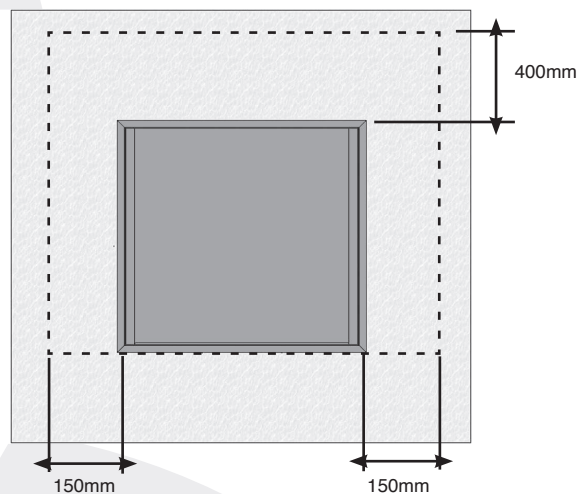

Appliance:
Extremely hot

HEARTH INSTALLATION

When installing at floor level then it will require a hearth to protect the floor.

This appliance must stand on a noncombustible hearth that is at least 12mm thick and projects to the following dimensions:

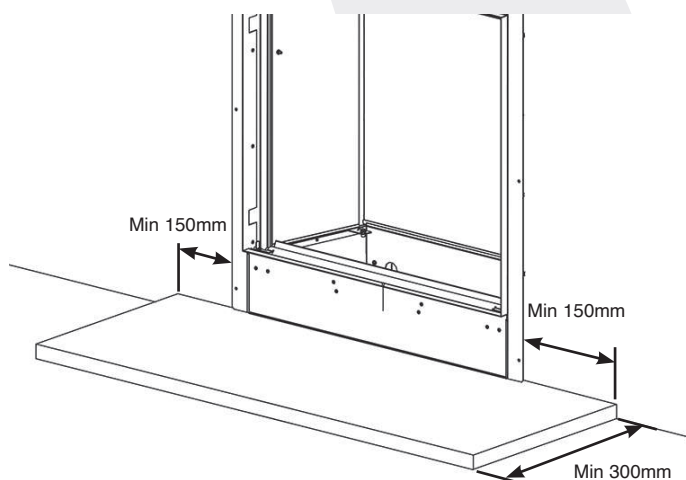

If this appliance is fitted less than 150mm from the floor, then it will require a hearth to protect the floor. The hearth should have a minimum dimension of 12mm thick, projecting 300mm in front and 150mm either side of the appliance.

STUDWORK INSTALLATION



Onyx recommend building the enclosure from the following materials:

Metal Studwork

Non-combustible board:

Masterboard or Promafour - NOT PINK BOARD

Heat Resistant Plaster: Purimacho (any spider cracks that develop after installation will need to be rubbed down and refilled with Purimacho heat resistant filler to stabilise).

Ensure all distances to combustible materials are maintained.

If a studwork installation is used (eg. wooden framework and plasterboard), combustible parts of the studwork must not be any closer than the minimum dimensions shown in the diagrams. NOTE: These dimensions must be maintained even if the combustible materials is protected by non-combustible linings.

Do not pack the void around or above the appliance with insulation materials such as mineral wool.

A removable access hatch must be left in the side of the chimney breast for future servicing and inspection of the appliance.

Build the studwork chimney breast to the desired size. Ensure that the clearances to combustible materials is maintained.

MINIMUM COMBUSTIBLE MATERIAL CLEARANCES

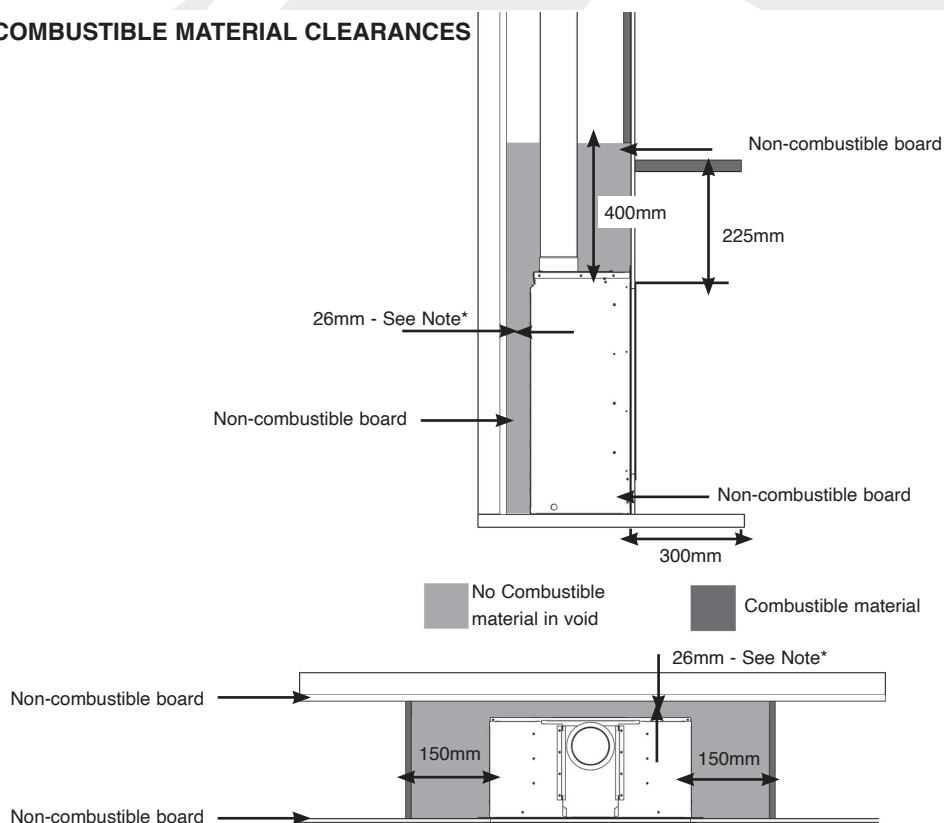

*** All combustible materials must be removed from behind the appliance or a minimum distance of 100mm is required where the combustible material is protected by non combustible board.**

It is recommended that a marble slip or similar material is used when fitting cassette fireplaces into a plastered surface, in order to allow for heat dissipation. Also allow adequate time for newly plastered areas to dry out. Rapid drying can create cracks. If in doubt, seek the advice of a professional plasterer.

Parts of this appliance become hot during normal use. It is therefore recommended that a suitable fire guard be used for protection of young children and the infirm.

PRE-INSTALLATION

REMOVING THE GLASS FRAME

Remove the glass door by removing the 2 side trims.
These are held on by magnets.

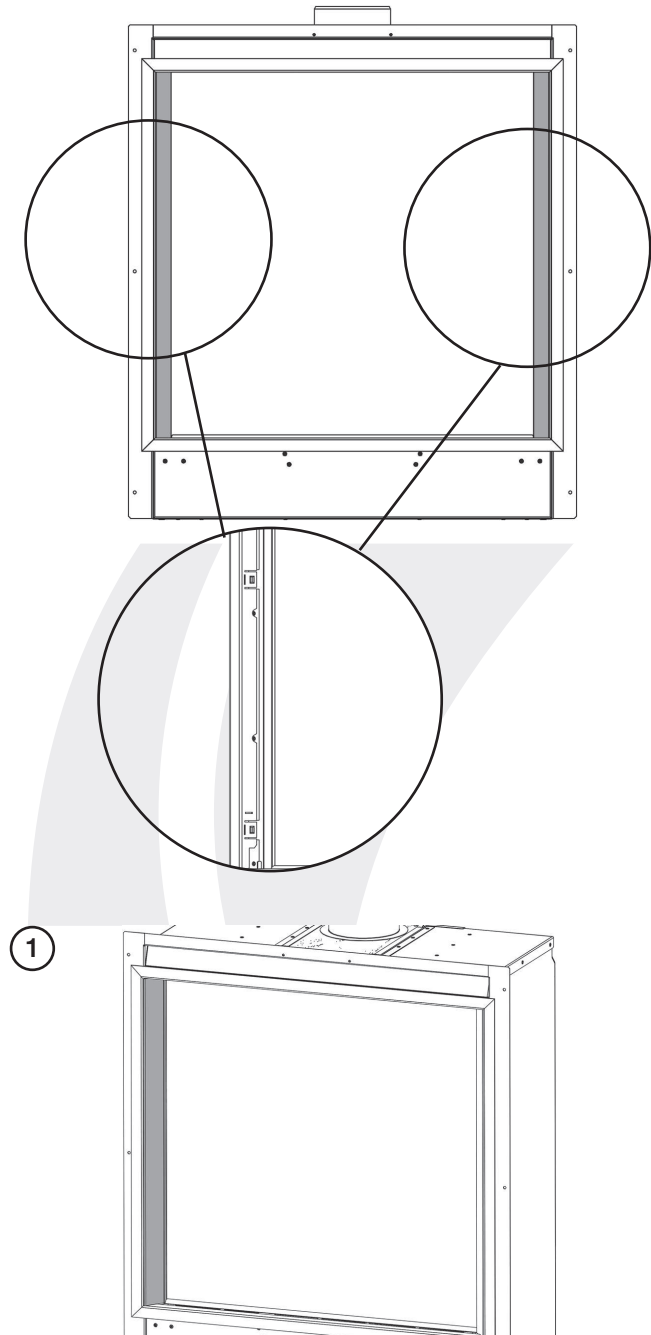

2

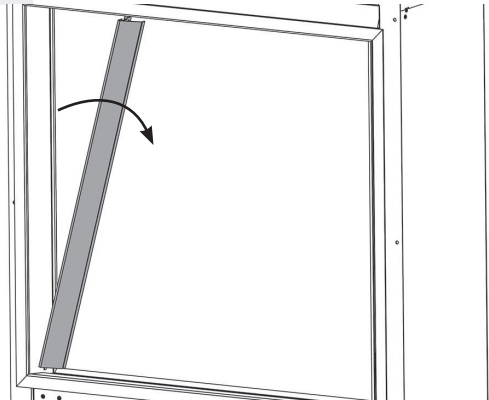

3

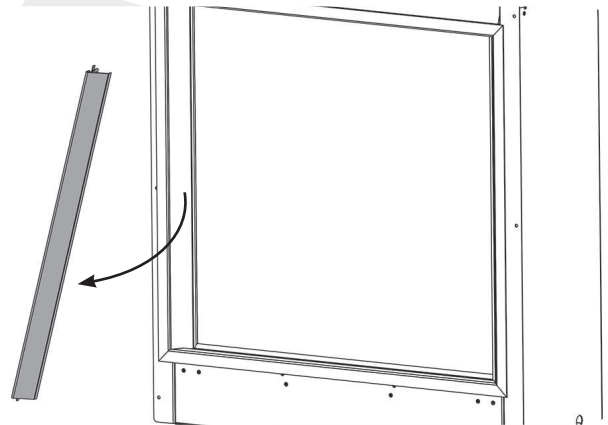

4

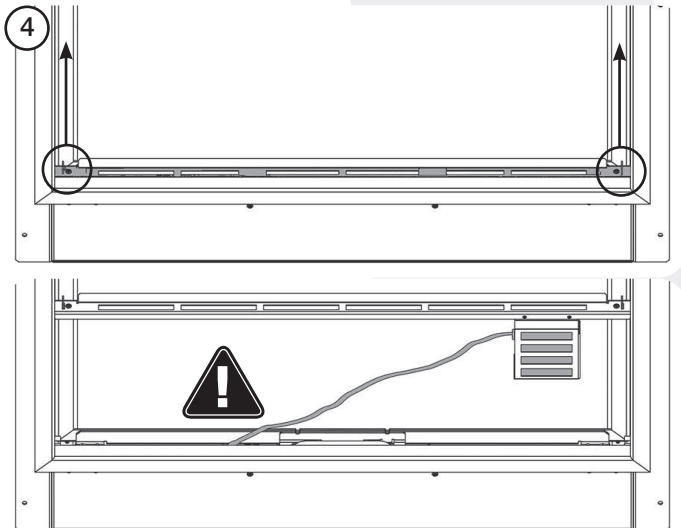

i

The Battery Box cannot be disconnected from the Gas Valve at this stage.
DO NOT STRETCH THE WIRE.

onyx

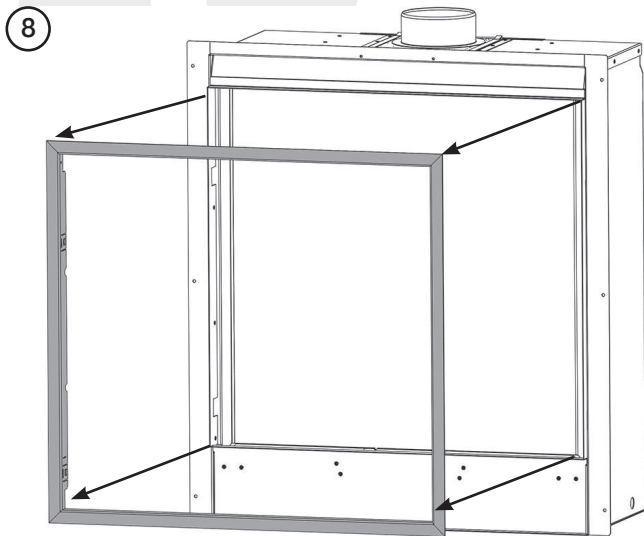
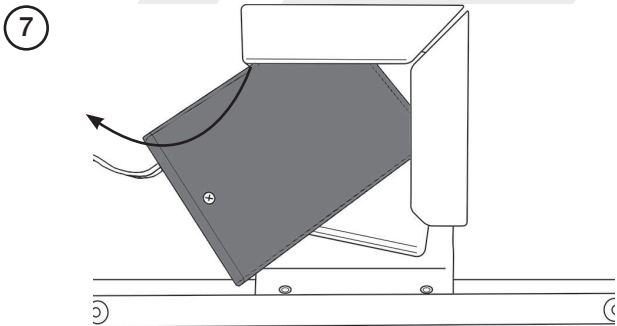
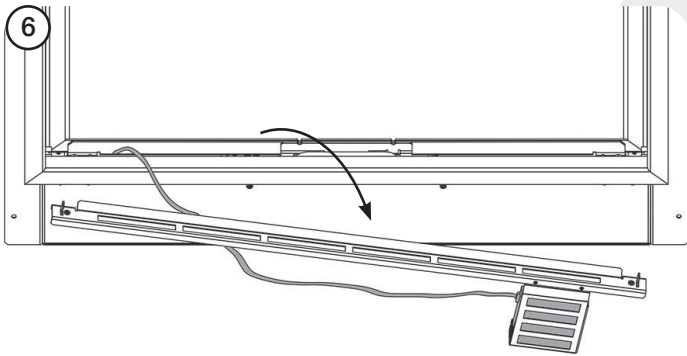
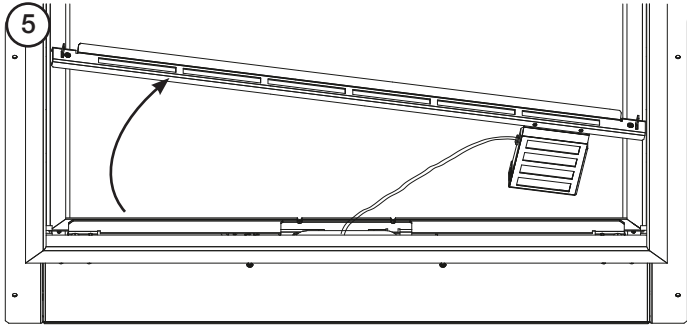

(Edge Plus Frame only)

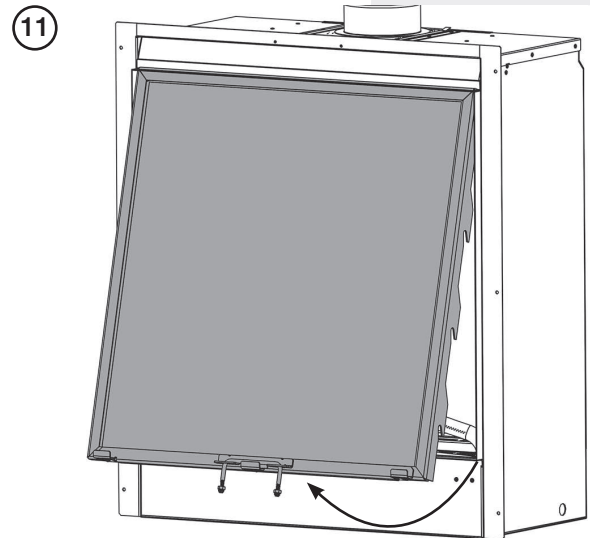
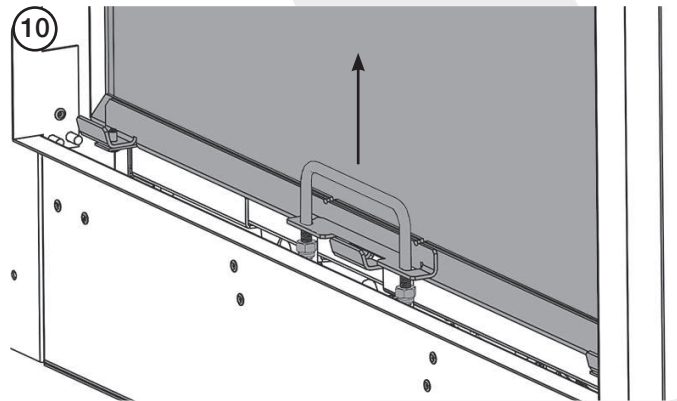
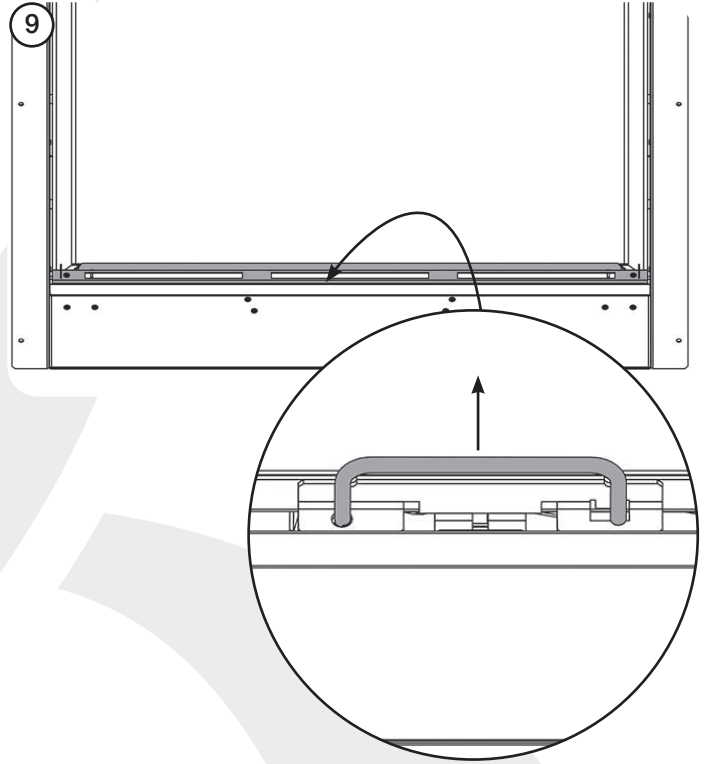

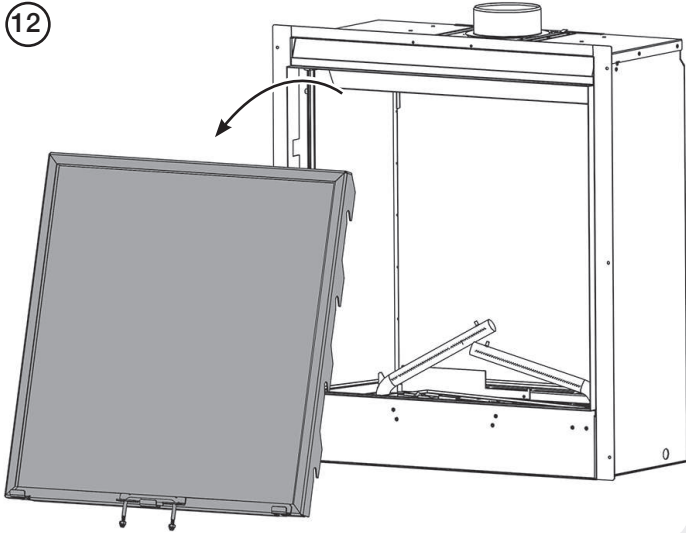

REMOVING THE BURNER ASSEMBLY

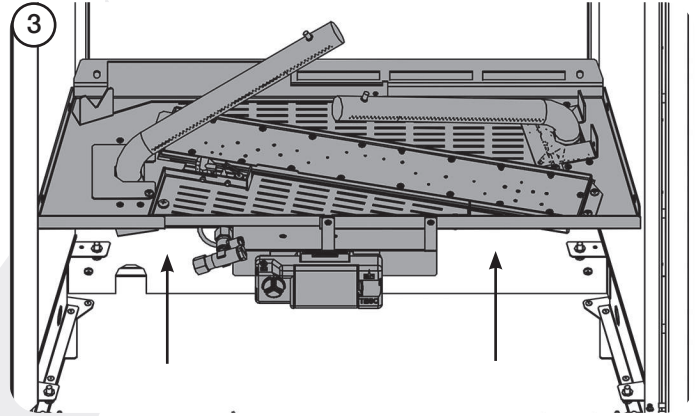
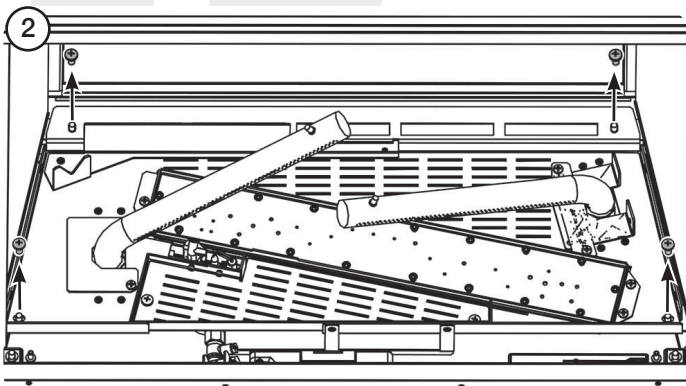
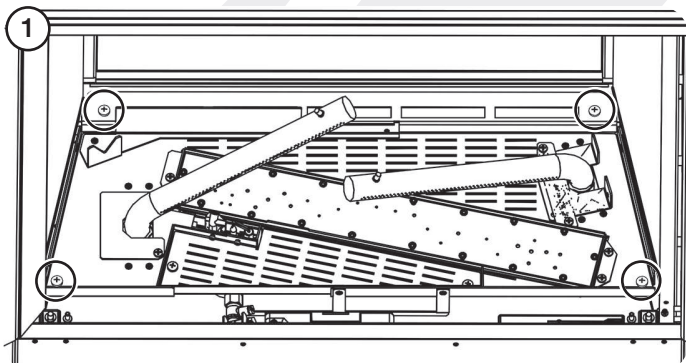

IMPORTANT: REFER TO DATA BADGE AND TECHNICAL SPECIFICATION AT THE FRONT OF THE MANUAL TO ENSURE THE APPLIANCE IS CORRECTLY ADJUSTED FOR THE GAS TYPE AND CATEGORY APPLICABLE IN THE COUNTRY OF USE.

FOAM SEAL

Fix the self adhesive foam seal around the back of the fixing flange of the appliance.

1

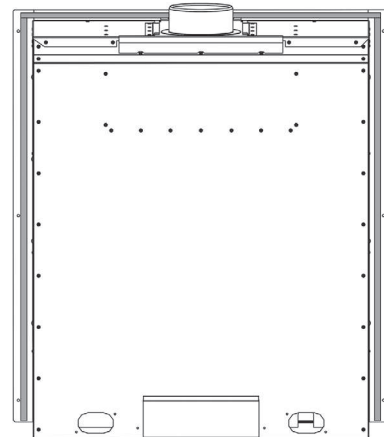

FLUE ASSEMBLY



All flue installations must be constructed in accordance with the rules in force. UK - Building Regulations: Approved Document J.

For additional information please refer to Site Requirements section.

Options 1 and 2 above can be:

- Top exit with a liner - 5" (127mm)
- Rear exit without a liner - 7" (178mm) minimum

The appliance is supplied with a flue fixing plate to attach the flue liner to the appliance within the aperture.

If a flexible liner is to be used check the seal on the inner lip of the spigot plate is intact. Replace if necessary.

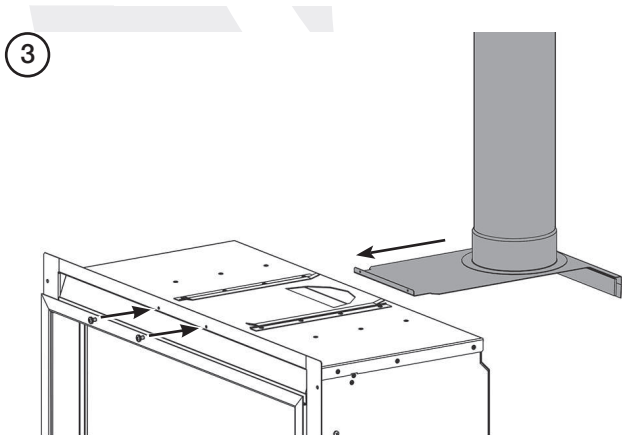
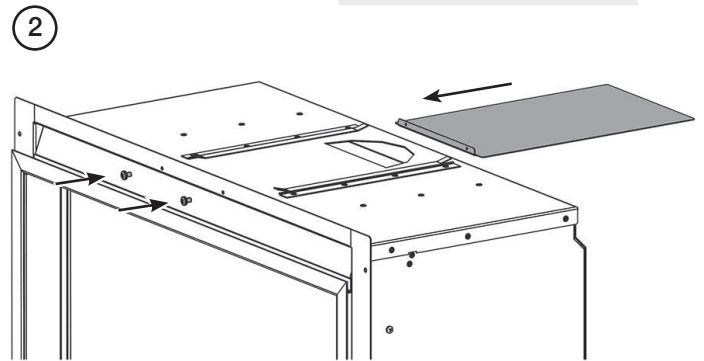
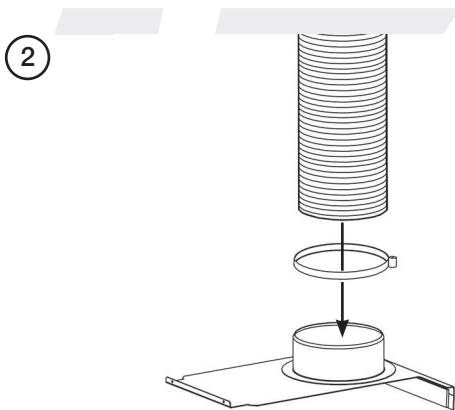
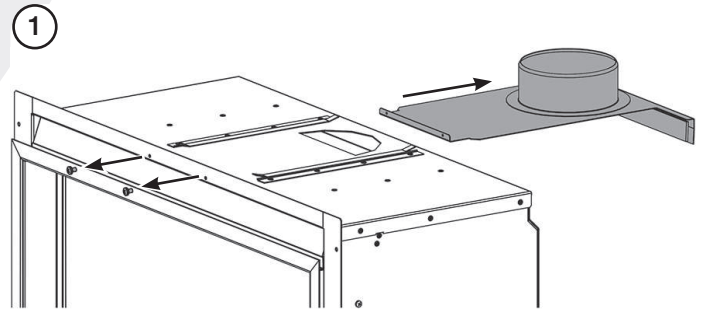
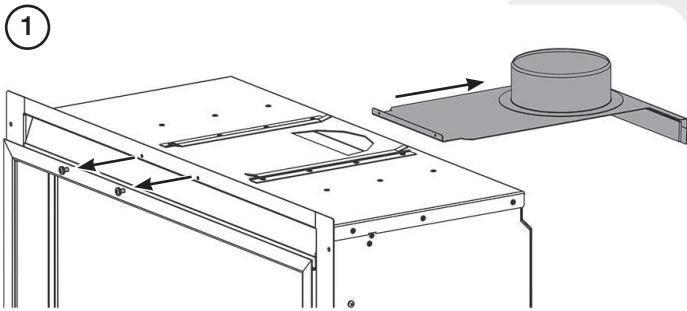
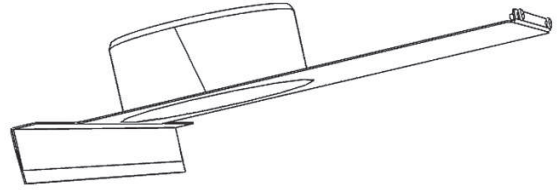

The flue must be in good condition and clear products of combustion, see Installation Instructions, Commissioning.

INSTALLATION

MASONRY CHIMNEY INSTALLATION

This appliance is designed so that non-combustible board can be taken right up to the edge of the flange of the appliance.

Prepare the flue connection using the chosen method described.

Connect the flue and install the appliance into the aperture. At the same time ensure that the gas pipe passes through the silicon panel at the back of the appliance.

Secure the appliance through the 6 fixing holes using the screws provided.

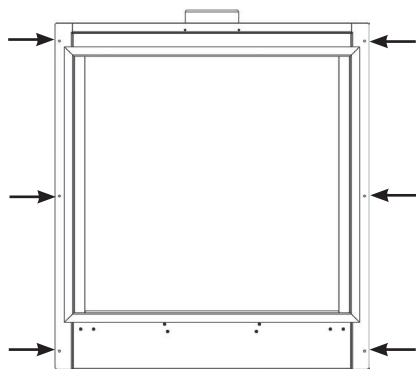

Attach the Compression Elbow to the inlet pipe and secure to the bracket on the inside of the firebox.

Build the chimney breast up to coincide with the edge, allowing for the front to be skimmed level.

Fit non-combustible board to the chimney breast around the appliance, using the distance to combustibles detailed.

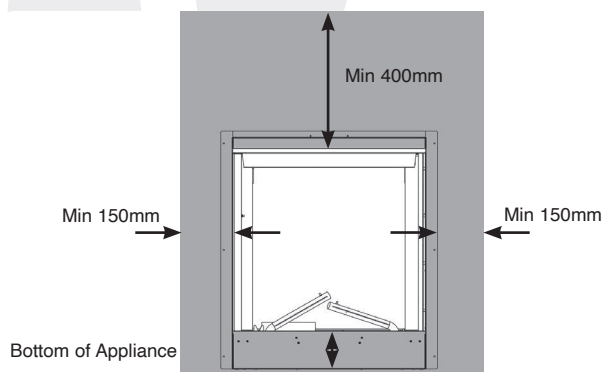

Fit plasterboard to the remaining of the chimney breast front.

Apply a heat resistant plaster around the appliance using the distance to combustibles detailed.

Apply a plaster finish to remaining chimney breast front.

INSTALLATION

ENCLOSURE CONSTRUCTION

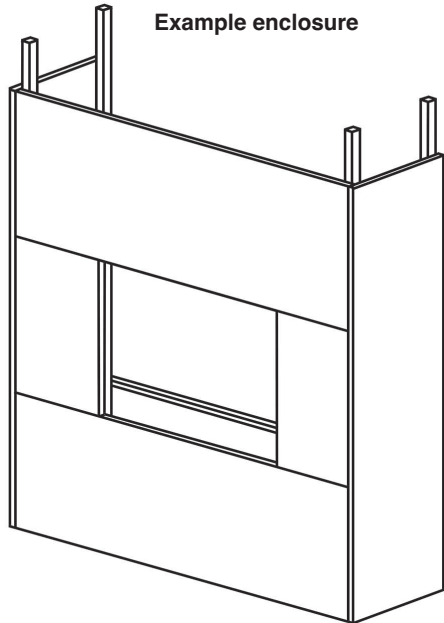

Onyx recommend building the enclosure from the following materials:

Metal Studwork
Non-combustible board:
Masterboard or Promafour - NOT PINK BOARD
Heat Resistant Plaster: Purimacho (any spider cracks that develop after installation will need to be rubbed down and refilled with Purimacho heat resistant filler to stabilise).

Ensure all distances to combustible materials are maintained

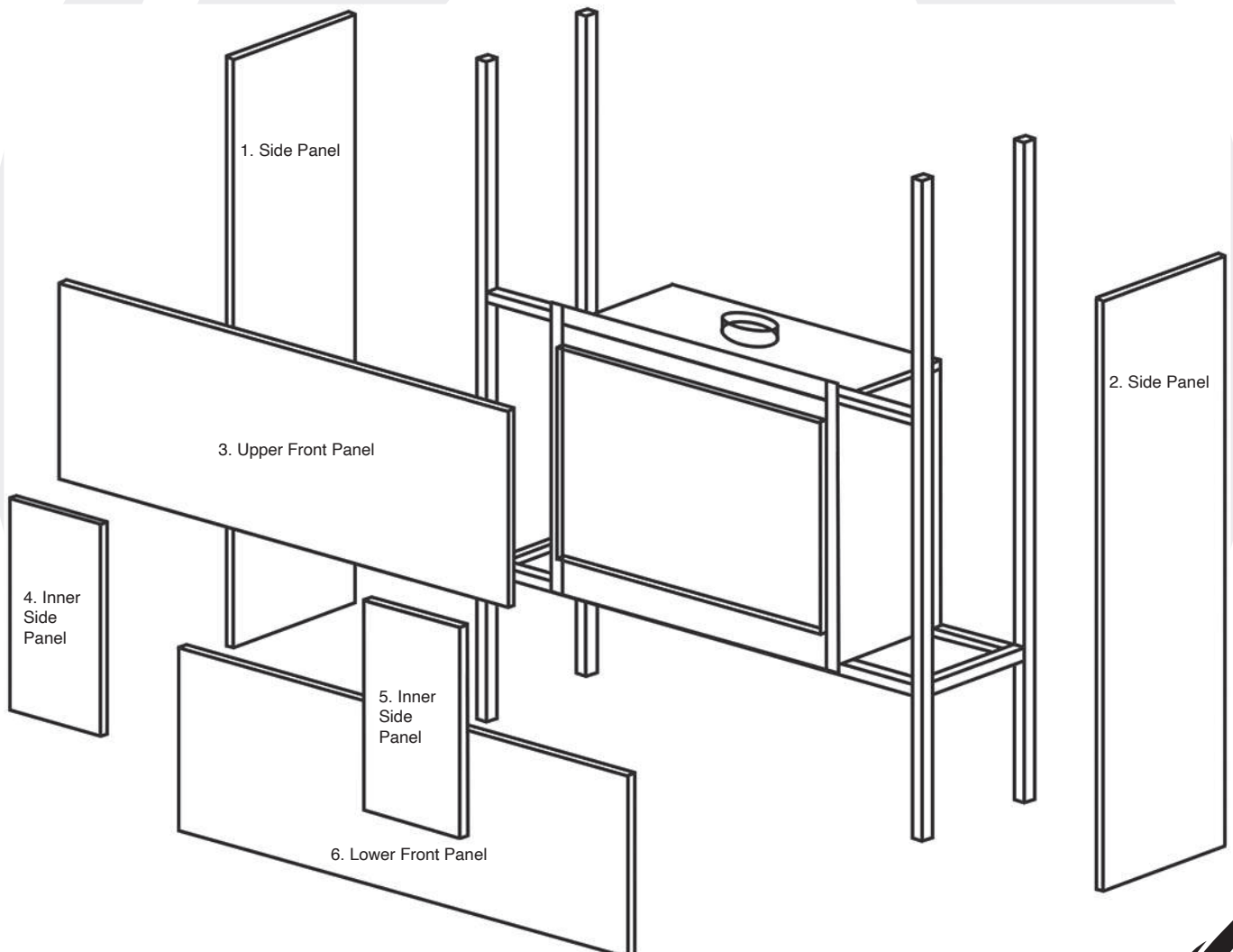

CUTTING TEMPLATES

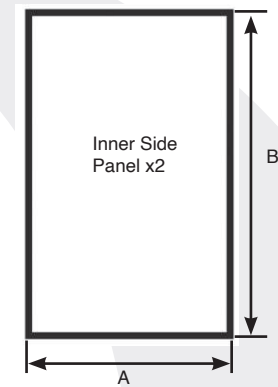
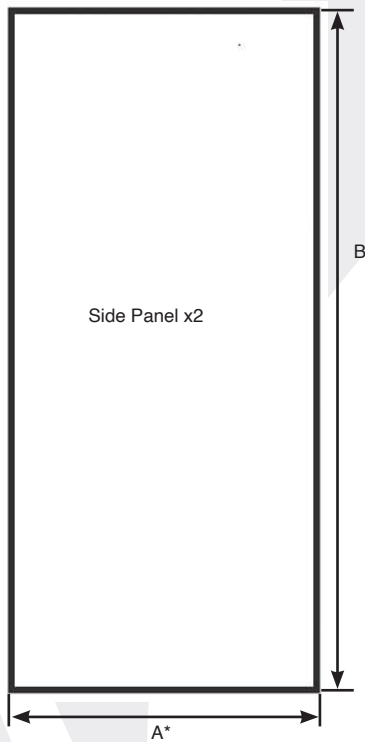
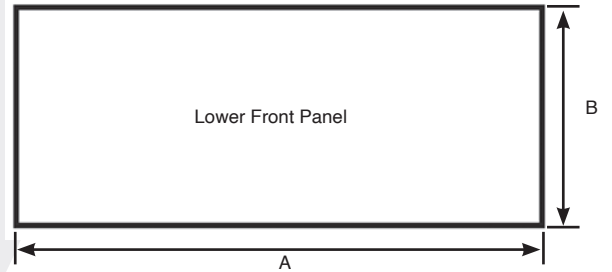
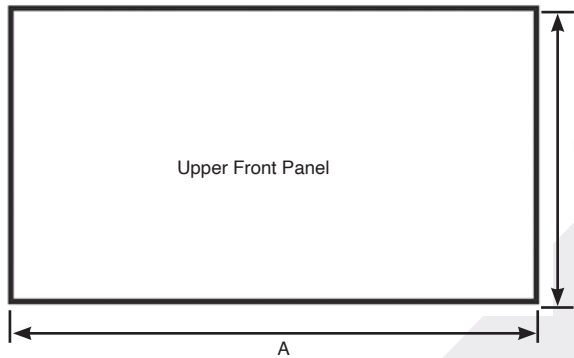

PANEL	A (MIN)	B (MIN)
Upper Front Panel	950	475
Lower Front Panel	950	130
Side Panel x 2	*	1205
Inner Side Panel	150	600

! * All combustible materials must be removed from behind the appliance or a minimum distance of 100mm is required where the combustible material is protected by non combustible board.

PANEL	A (MIN)
Side Panel	350mm

EDGE FRAME INSTALLATION

1

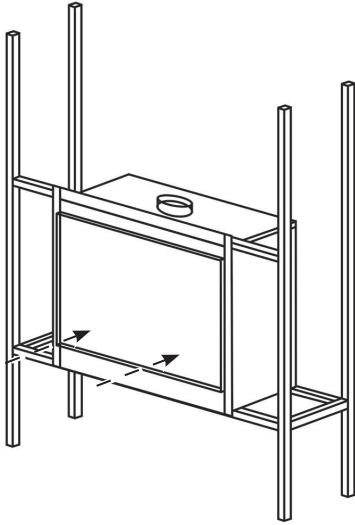

4

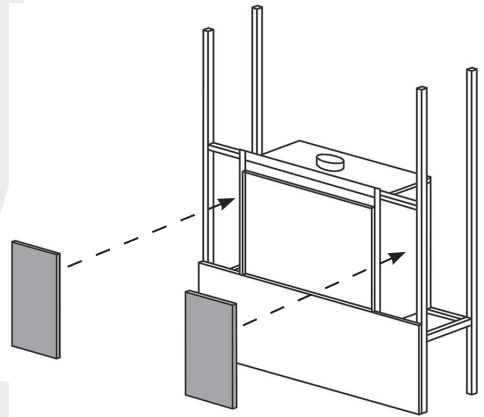

2

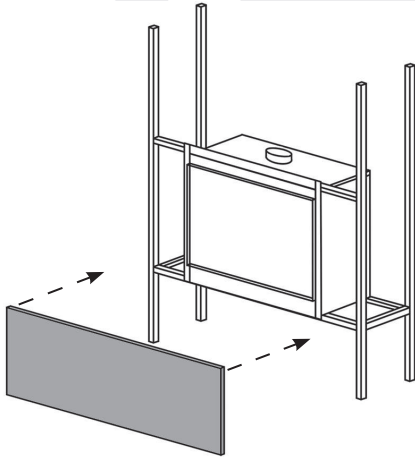

5

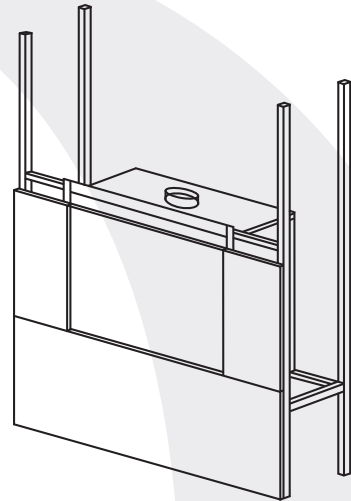

3

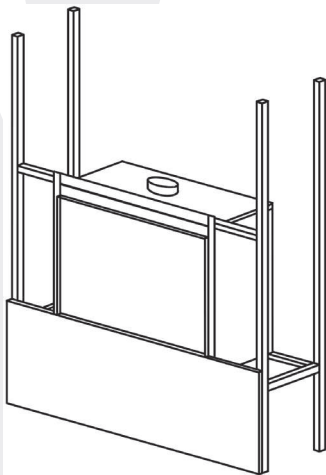

6

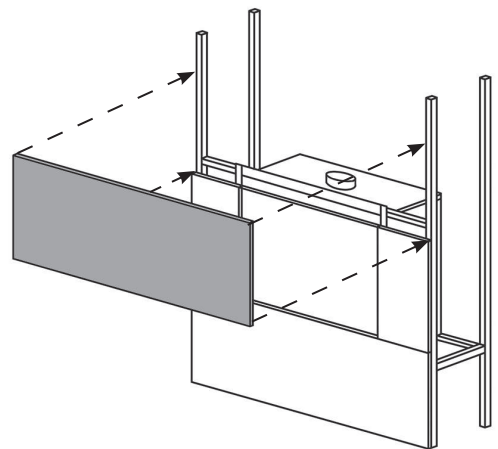

7

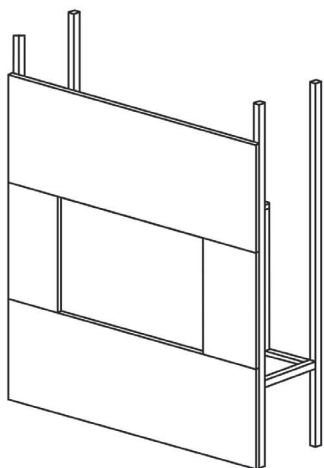

8

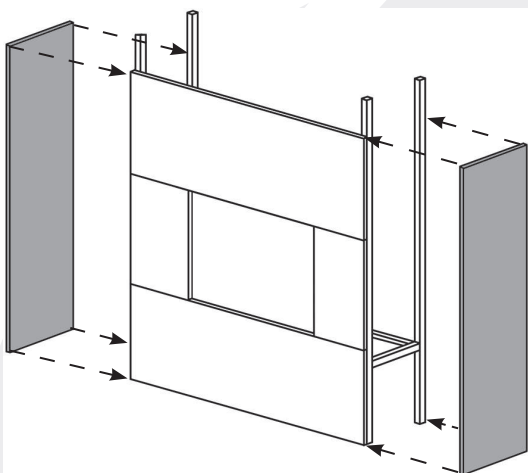

9

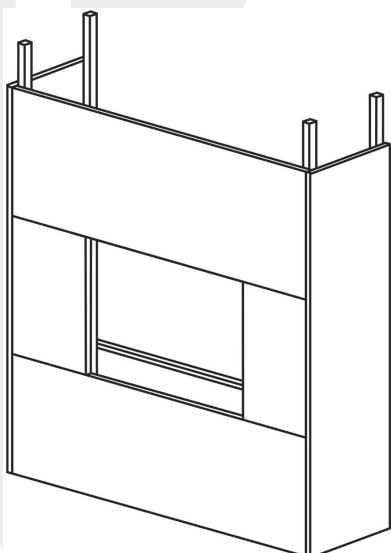

FITTING THE BURNER ASSEMBLY

Ensure there is enough length on the Inlet Pipe to reach the front of the firebox.

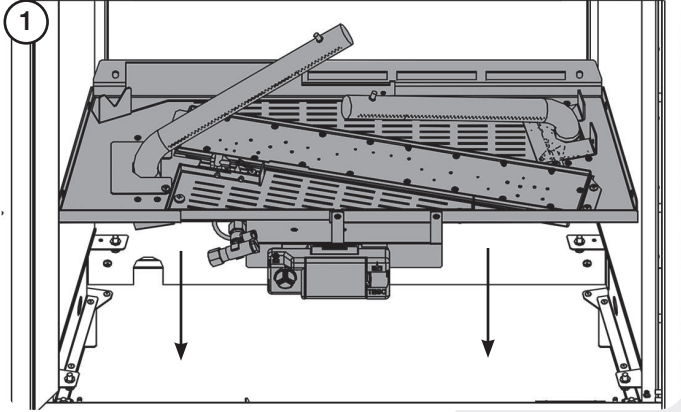

Attach the Inlet Pipe to the Compression Elbow.

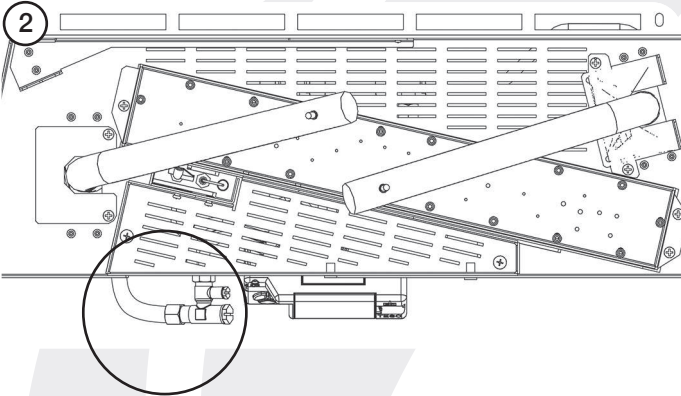

PURGE THE SUPPLY PIPE. This is essential to expel any debris that may block the gas controls.

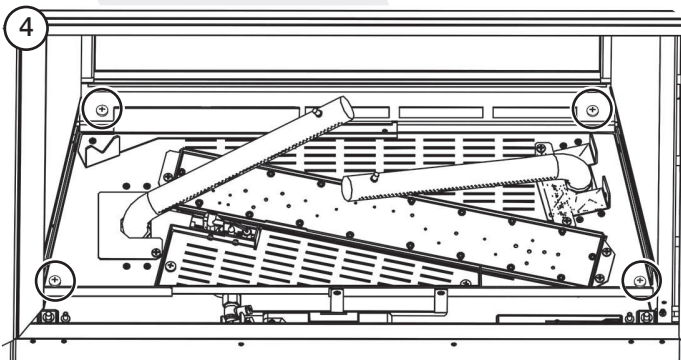
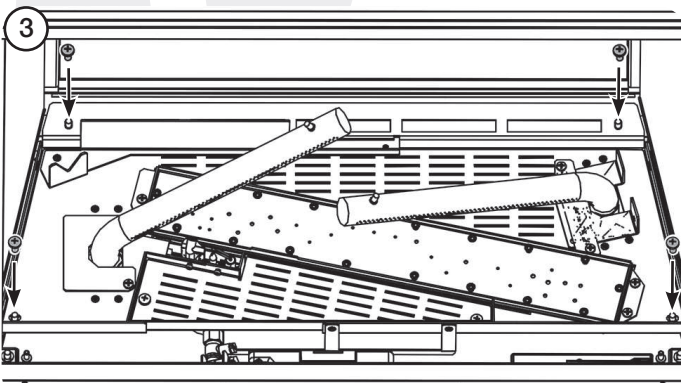

GAS SOUNDNESS PRESSURE CHECK

Connect a suitable pressure gauge to the test point located on the inlet fitting and turn the gas supply on. Light the appliance and check all gas joints for possible leaks. Turn the appliance to maximum and check that the supply pressure is as stated on the databadge. Turn the gas off and replace the test point screw, turn the gas on and check the test point for leaks.

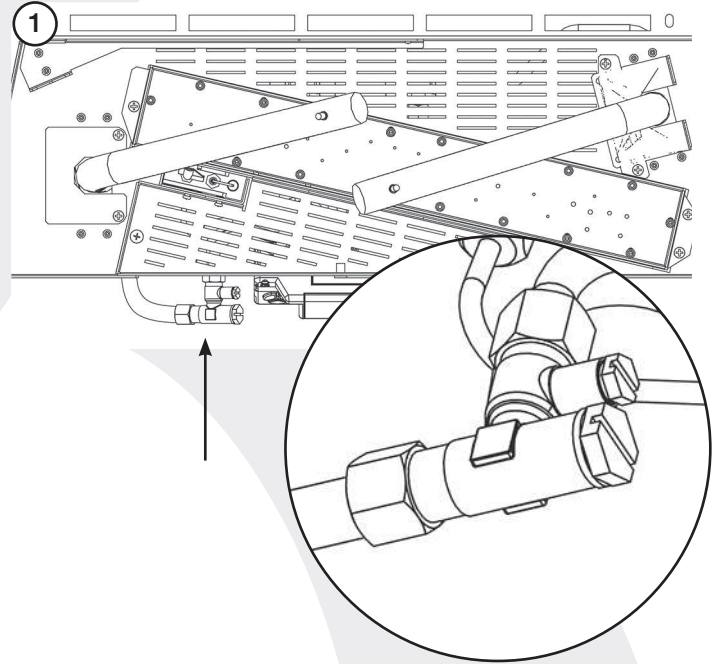

Check the function of the handset, if there is no communication between the remote control and the appliance, see Commissioning Section.

LOG LAYOUT

LOGS MUST BE POSITIONED ACCORDING TO THE FOLLOWING INSTRUCTIONS TO GIVE THE CORRECT FLAME EFFECT.

Ensure the Burner Tray and Log Burners are clean and free from any debris.

LOGS

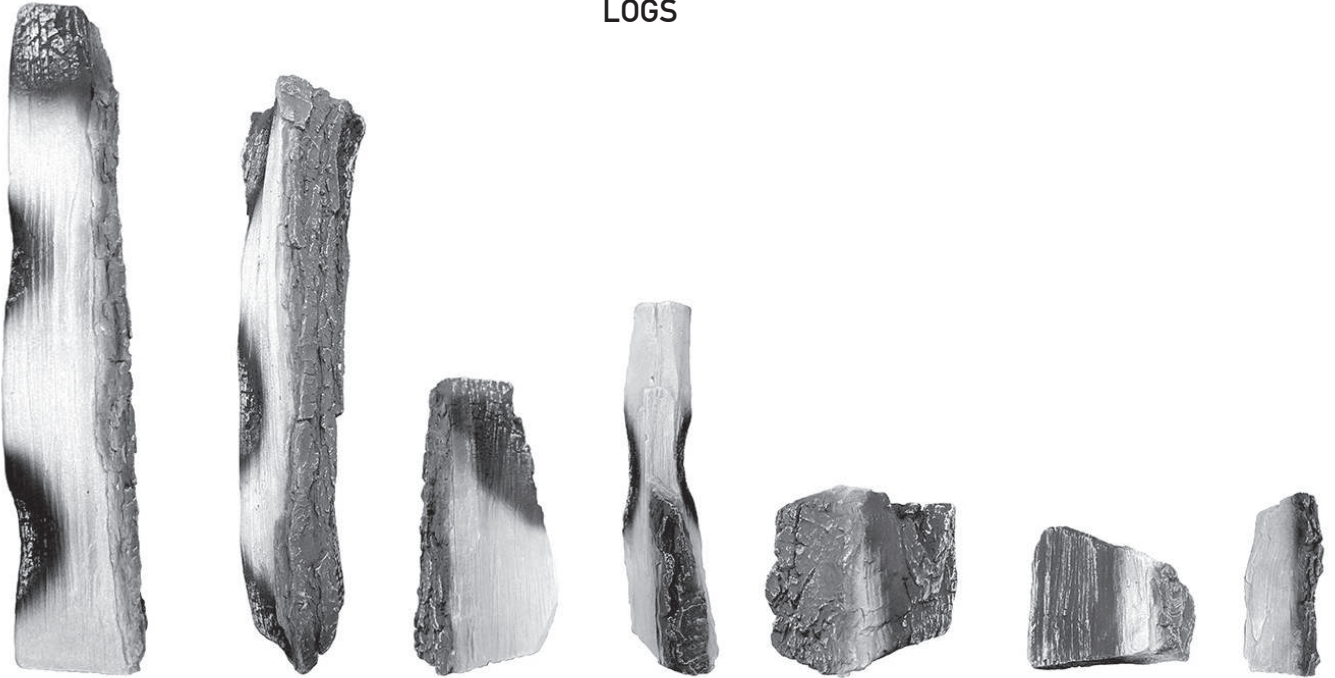

EMBERS



VERMICULITE



1

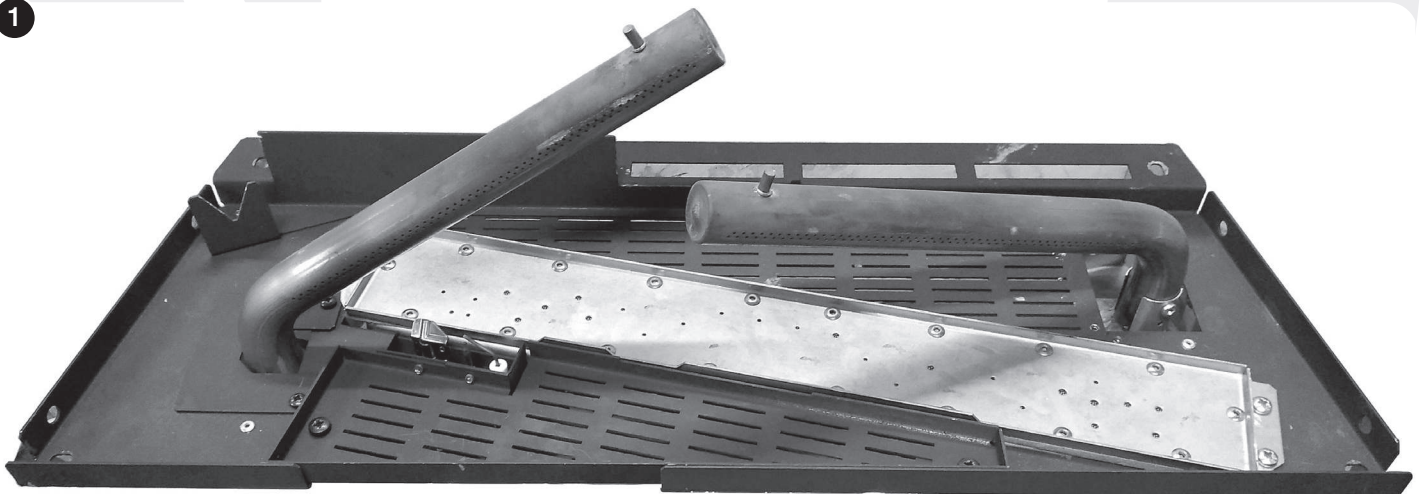

onyx

2

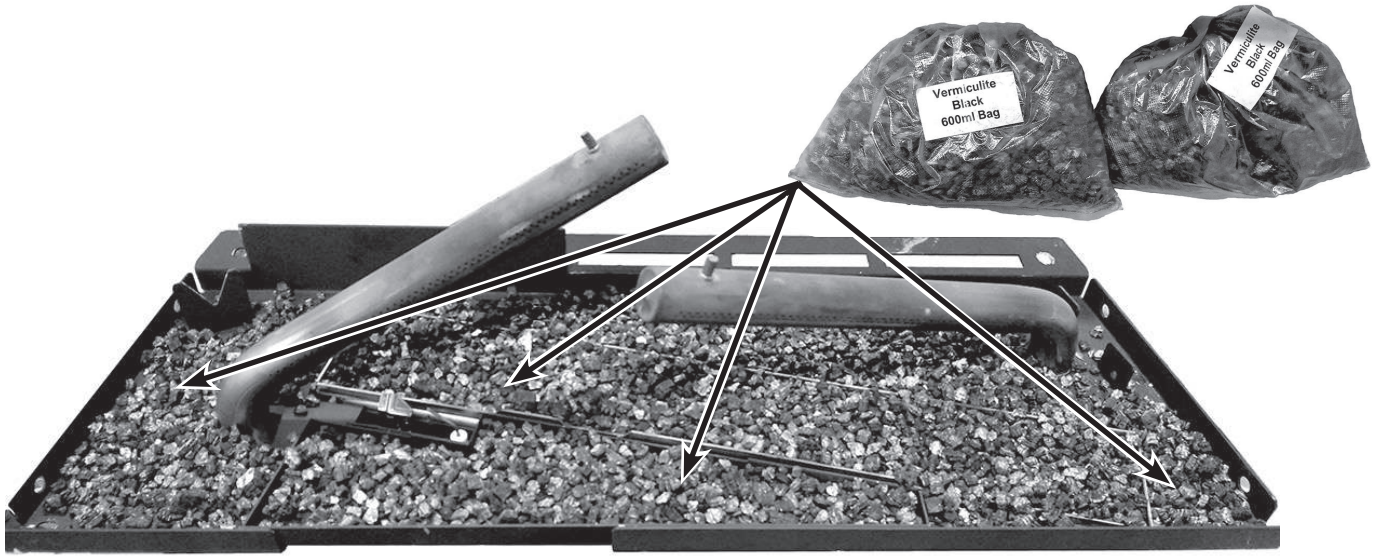

3

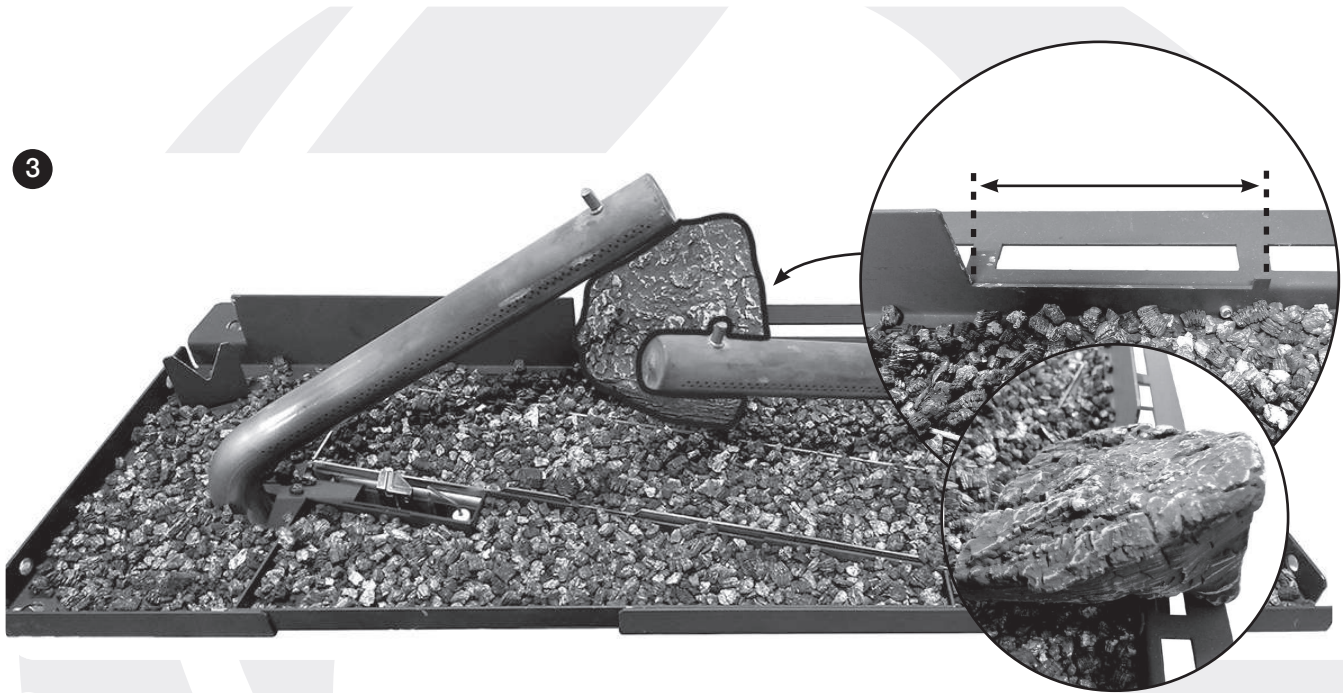

4

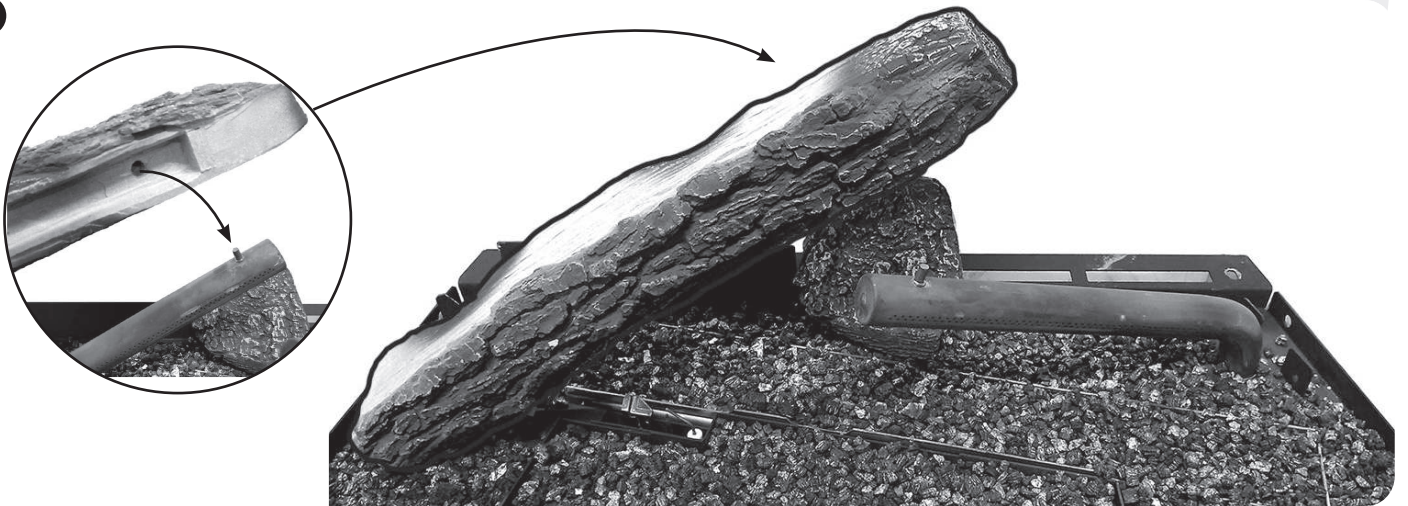

onyx

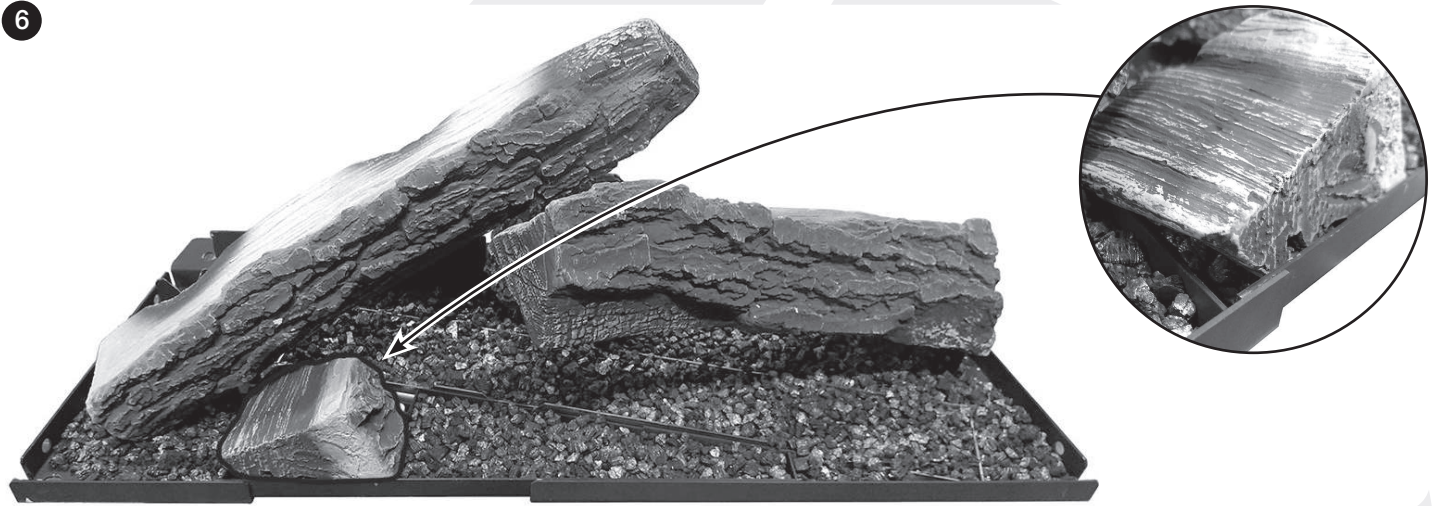
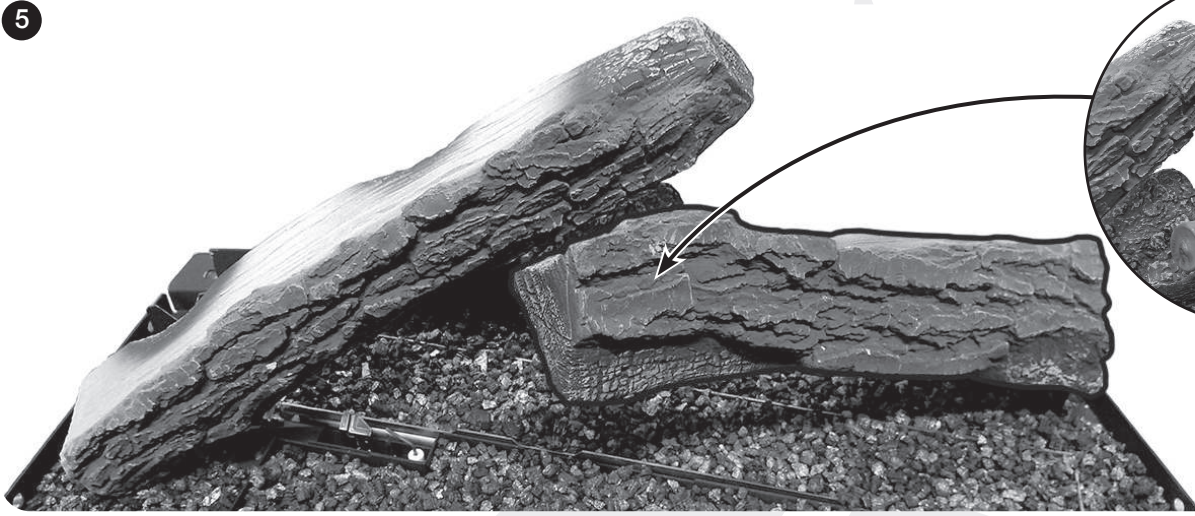

onyx

8



9

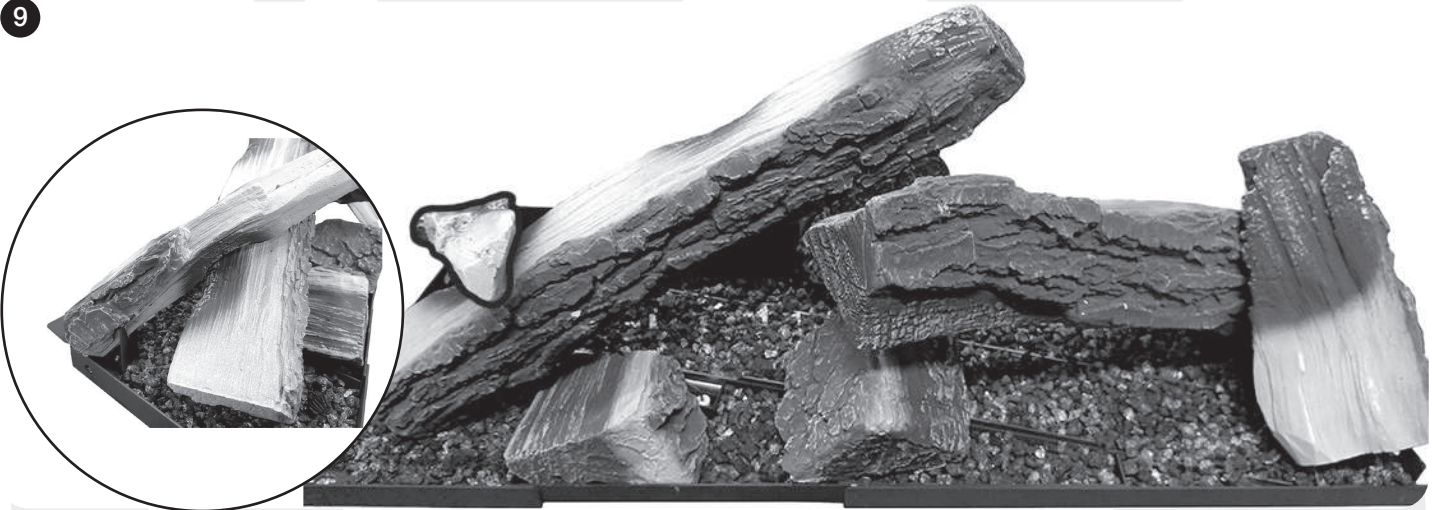

10



11



NOTE: ENSURE THAT THE LOGS ARE POSITIONED AS ABOVE. ONLY USE THE CORRECT AMOUNT OF LOGS AS SPECIFIED IN THE DIAGRAMS.

EMBAGLOW

Sparingly spread an amount of the Embaglow fibres provided, this will create a glowing effect when the appliance is lit.

Take care not to use more than half a packet per application.
WARNING - DO NOT PLACE NEAR THE PILOT AREA.

12

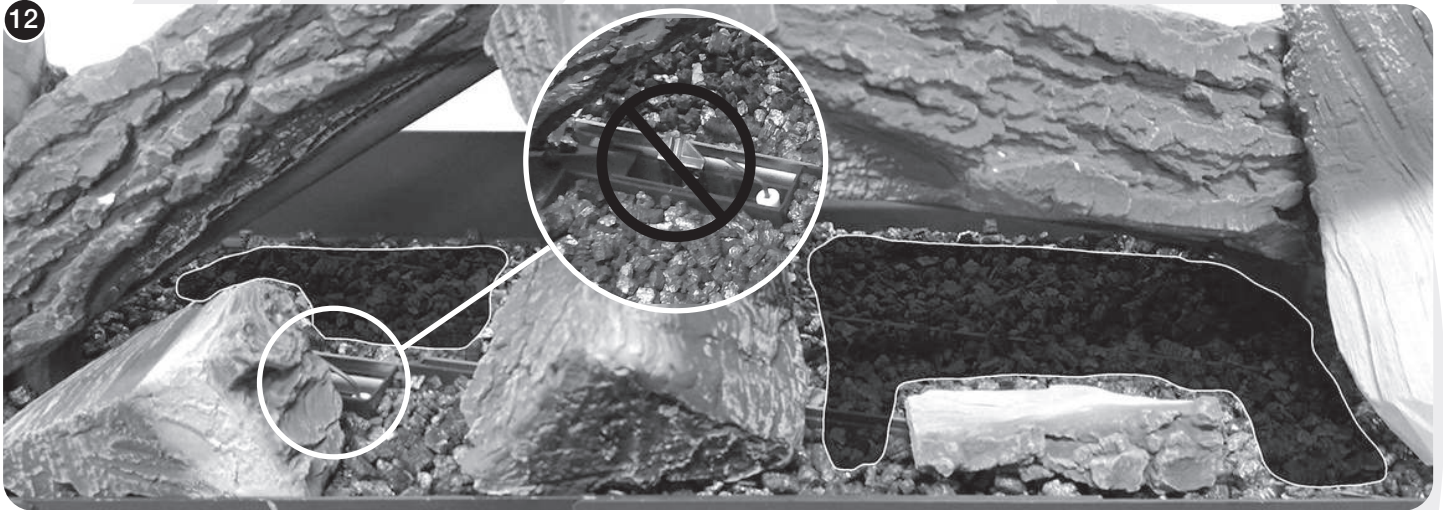

NOTE: ENSURE THAT THE LOGS ARE POSITIONED AS ABOVE. ONLY USE THE CORRECT AMOUNT OF LOGS AS SPECIFIED IN THE DIAGRAMS.

COMPLETION OF ASSEMBLY

Ensure that the rope seal on the back of the glass frame is intact.

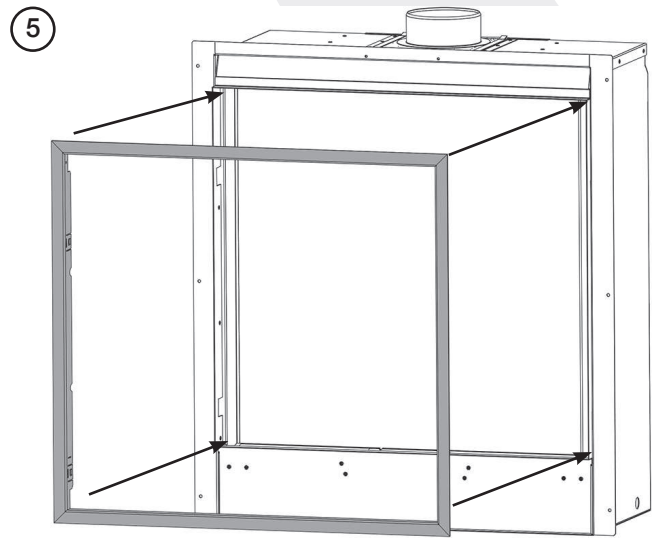
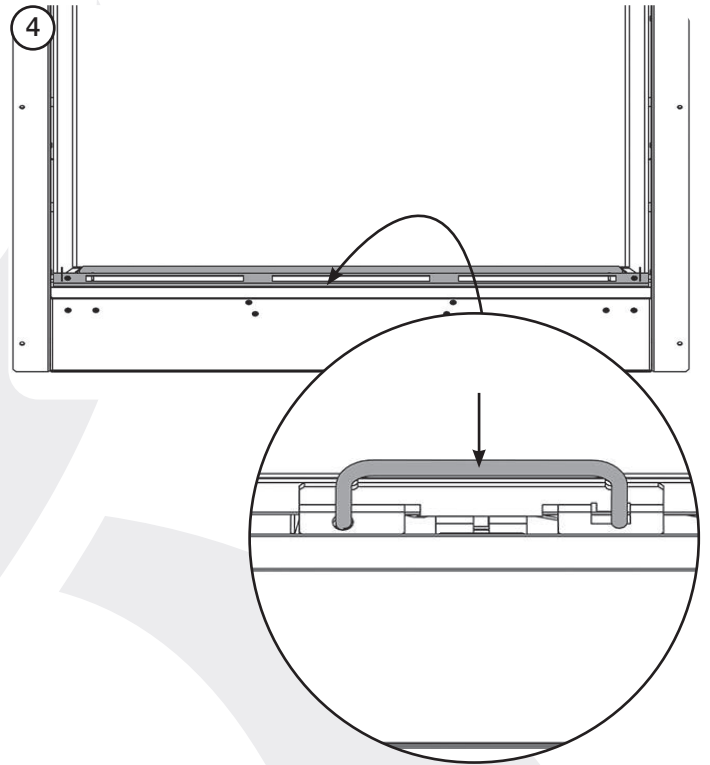
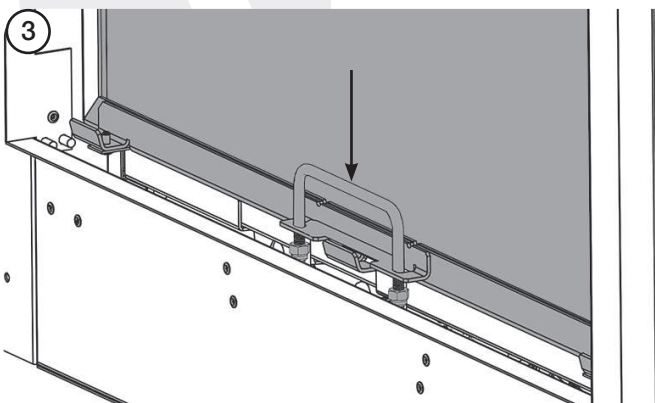
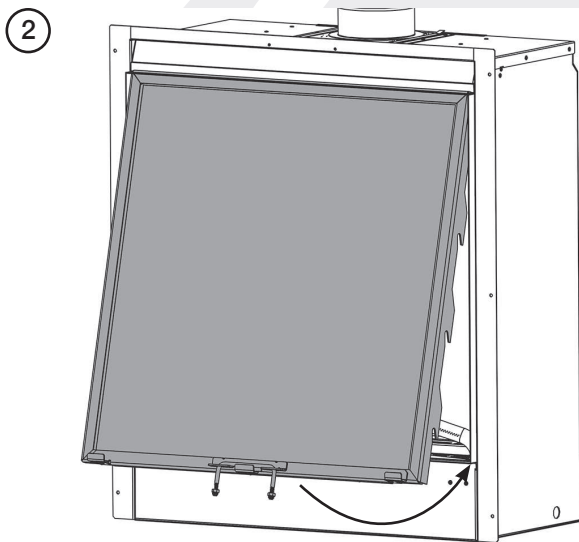
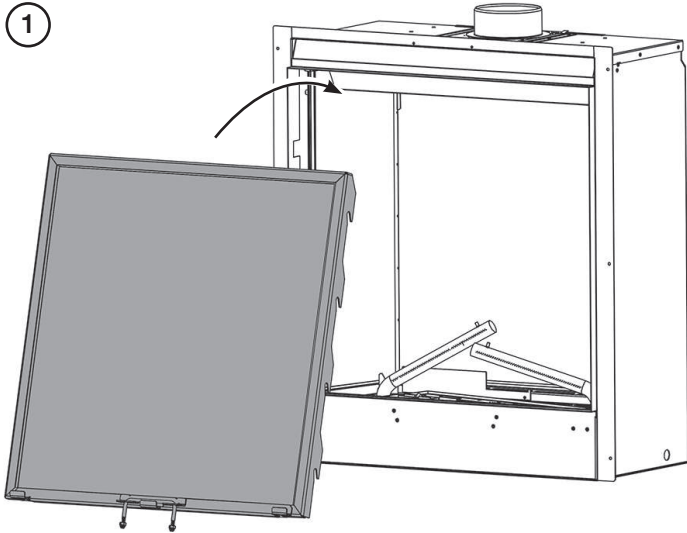

(Edge Plus Frame only)

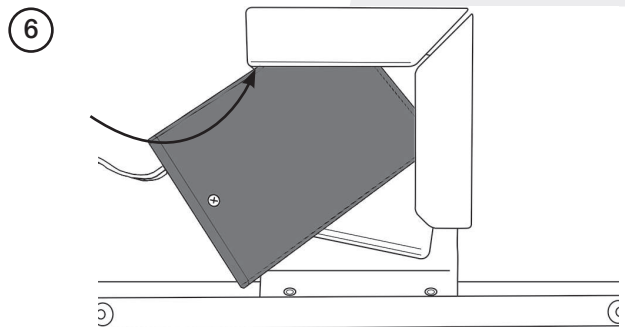

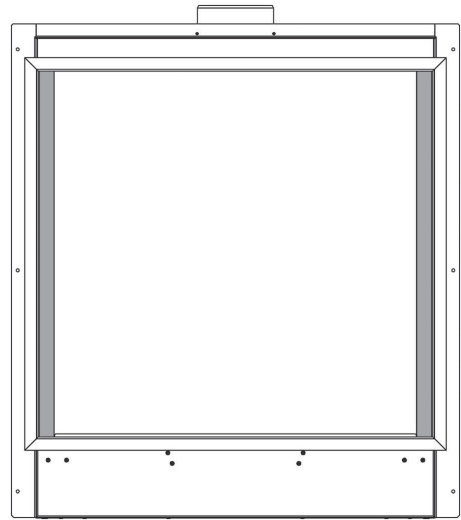
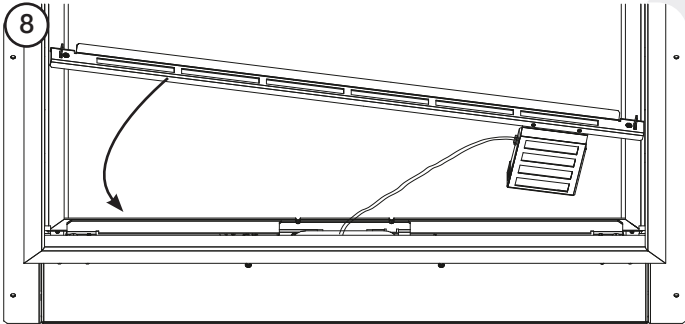
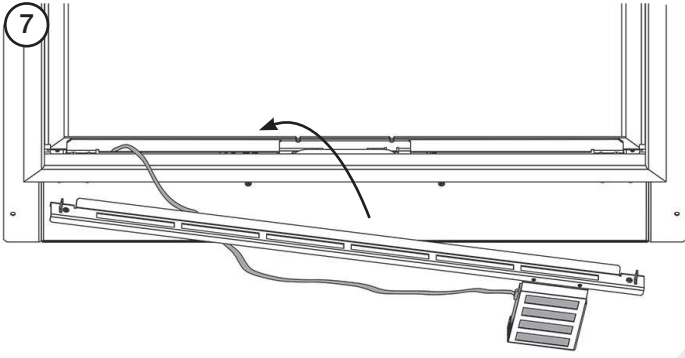

NEVER OPERATE THE APPLIANCE WHEN THE GLASS PANEL IS REMOVED OR BROKEN.

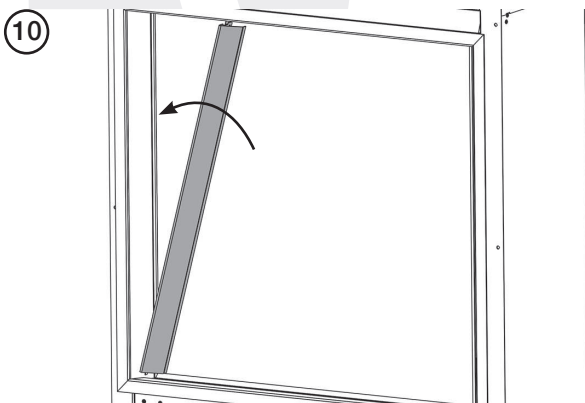
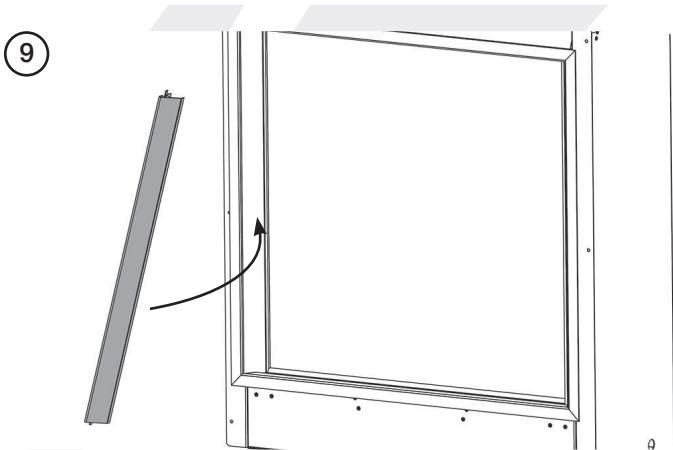

OPERATING THE APPLIANCE

There are two ways of lighting the appliance:

Using the **Manual Controls** on the Control Box (located on the appliance).

NOTE: THIS IS FOR INSTALLERS AND SERVICE ENGINEERS ONLY. NOT INTENDED FOR USE BY THE END USER.

By **Thermostatic Remote Control**.

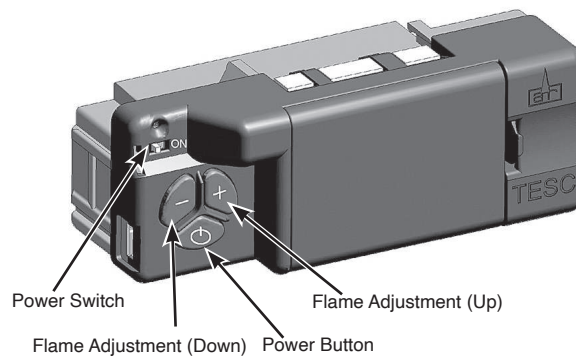

Power Switch
Flame Adjustment (Down) Power Button
Flame Adjustment (Up)

To operate the appliance the Power Switch on the Control Box must be switched ON (I).

i **Note: The Power Switch does not need to be turned off each time the appliance is not in use. However, if the appliance is left unattended for long periods of time (e.g. vacation), it is recommended to remove the batteries from the rear of the appliance.**

TURNING THE APPLIANCE ON:

Press and hold the  Power Button for 1 second and release. The burner will light approximately 2 to 3 seconds later.

Use + and - buttons to adjust the flame height between Minimum and Maximum.

TURNING THE APPLIANCE OFF

Press the  power button to turn the appliance off.

i **IMPORTANT: YELLOW FLAMES TYPICALLY APPEAR WHEN THE APPLIANCE HAS REACHED NORMAL OPERATING TEMPERATURE. THIS CAN TAKE UP TO 30 MINUTES.**

! **WARNING: IF THE APPLIANCE FAILS TO LIGHT OR BECOMES EXTINGUISHED IN USE, WAIT 3 MINUTES BEFORE ATTEMPTING TO RELIGHT.**

THE APPLIANCE WILL TAKE 3 AUTOMATIC ATTEMPTS TO RESTART. DO NOT INTERRUPT THE VALVE DURING THIS PROCESS.

MANUAL OPERATION (CONTROL BOX)

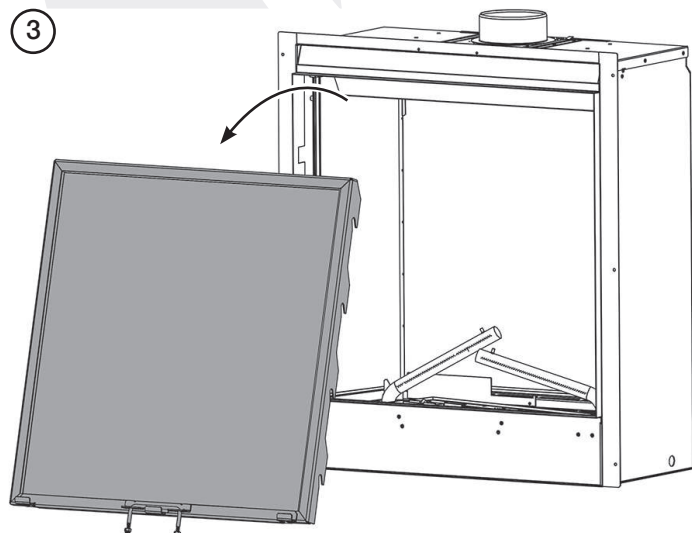
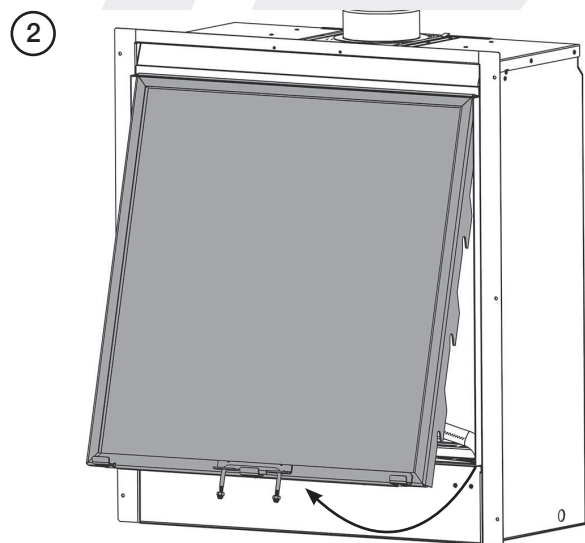
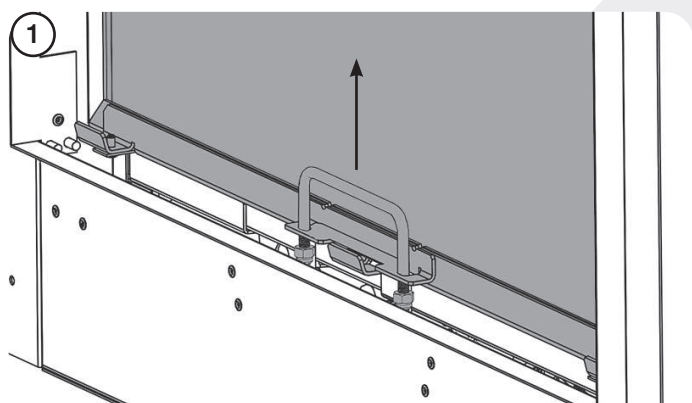

REMOTE CONTROL

To operate the appliance the Power Switch on the Control Box must be switched ON (I) .

i To activate the Remote Control it will be necessary to cradle the handset to unlock. The green light will illuminate to show the handset is ready to use. **IMPORTANT: Continue to cradle the handset throughout an operation to keep it unlocked.** If the green light goes off during an operation it will be necessary to reposition the handset so the light comes back on and restart the operation.



SETTING THE DISPLAY FOR 12 OR 24 HOUR CLOCK

Holding the remote to keep the green light on and the handset unlocked the handset will display an H:24.



24 denotes a 24 hour clock and 12 denotes a 12 hour clock.

Press the + or - button on the handset to toggle between the two settings. Press the SET button to confirm and progress to setting the day of the week.

SETTING THE DAY OF THE WEEK

Press and release the + and - buttons until the correct day of the week is shown on the display.



Mo = Monday, **Tu** = Tuesday, **We** = Wednesday, **Th** = Thursday, **Fr** = Friday, **Sa** = Saturday and **Su** = Sunday.

Press SET to confirm the day of the week and progress to setting the time.

SETTING THE HOUR

Press and release the + or - button to change the hour to the correct hour. Press SET to confirm and progress to setting the minute.



HANDSET INITIAL SET UP

Following initial set up or new pairing it will be necessary to set the time and date.

i Note: Pressing SET button will advance the display to the next screen and pressing MODE button will return it to the previous setting.

SETTING THE TIME

Once the handset is paired the screen will show that the time is not yet set. The handset will then automatically progress to the next setup screen.



SETTING THE MINUTES

Repeat the process to change the minutes.

SETTING THE TEMPERATURE DISPLAY (CELSIUS OR FAHRENHEIT)

Press and release the + or - button to toggle between C and F. When the display shows the desired symbol, press and release the SET button to store.



Place the handset down and wait until the home screen is displayed and the unlock light goes off.

! ALL THE NECESSARY SETTINGS REQUIRED HAVE NOW BEEN COMPLETED. ANY FURTHER FUNCTIONS ON THIS HANDSET ARE FOR FACTORY SETTING AND NOT TO BE USED.

The Handset is now ready to operate the appliance.

OPERATING THE APPLIANCE

TURNING THE APPLIANCE ON

Press the  Power Button until Pilot flashes on the display.

Release the  Power Button and the Flame symbol will appear on the display.

If the button is held the command will be cancelled for safety reasons.

Holding the handset to unlock, use + and - buttons to adjust the flame height between Minimum and Maximum.

TURNING THE APPLIANCE OFF

Holding the handset to unlock, press the power button to turn the appliance off.

i IMPORTANT: YELLOW FLAMES TYPICALLY APPEAR WHEN THE APPLIANCE HAS REACHED NORMAL OPERATING TEMPERATURE. THIS CAN TAKE UP TO 30 MINUTES.

! WARNING: IF THE APPLIANCE FAILS TO LIGHT OR BECOMES EXTINGUISHED IN USE, WAIT 3 MINUTES BEFORE ATTEMPTING TO RELIGHT.

THE APPLIANCE WILL TAKE 3 AUTOMATIC ATTEMPTS TO RESTART. DO NOT INTERRUPT THE VALVE DURING THIS PROCESS.

Turning the appliance Off:

Press the OFF button to turn the appliance off. FOR SAFETY, YOU MUST WAIT 30 SECONDS BEFORE LIGHTING THE APPLIANCE AGAIN.

i IMPORTANT: YELLOW FLAMES TYPICALLY APPEAR WHEN THE APPLIANCE HAS REACHED NORMAL OPERATING TEMPERATURE. THIS CAN TAKE UP TO 30 MINUTES.

! WARNING: IF THE APPLIANCE FAILS TO LIGHT OR BECOMES EXTINGUISHED IN USE, WAIT 3 MINUTES BEFORE ATTEMPTING TO RELIGHT.

FOR FULL OPERATING INSTRUCTIONS AND TROUBLESHOOTING SEE USER SECTION.

COMMISSIONING

Close all doors and windows in the room.

Ignite the appliance and operate on maximum for 10 minutes.

Position a lighted smoke match just inside the draught diverter opening (under the canopy) and check all smoke is drawn in along the opening, see Diagram.

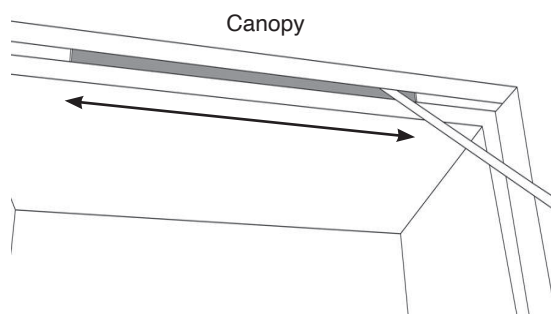

If there is any doubt, run the appliance for a further 10 minutes, and repeat the test.

If there are any extractor fans in adjacent rooms, the test must be repeated with the fans running on maximum and interconnecting doors open.

IF SPILLAGE PERSISTS, DISCONNECT THE APPLIANCE AND SEEK EXPERT ADVICE.

Complete the Commissioning Checklist at the front of this manual covering:

- Thermocouple soundness checks. This is to include ensuring the thermocouple is secure on the pilot bracket assembly, lead connection and integrity.

- Flue checks
- Gas checks
- Log layout - flame picture

Upon completion of the commissioning and testing of the installation and correct operation of the appliance, the installer must instruct the user how to operate the appliance.

Guide the user through the User Instructions paying particular attention to:

- a) Regular servicing (See User Instructions).
- b) Ventilation (See User Instructions) - point out the ventilation positions where applicable.
- c) Hot surfaces (See User Instructions).

PAIRING THE APPLIANCE

It may be necessary to pair the handset to the appliance following servicing.

Ensure the Power switch on the Control Box is in the ON (I) position.

Cradle the handset to unlock. The green light must be illuminated for the handset to accept commands.

Simultaneously press and hold the - and + buttons on the Control Box, until the red light appears on the Control Box.



WARNING: IF THE + AND - BUTTONS ARE DEPRESSED FOR 20 SECONDS OR MORE THE LIGHT WILL EMIT A SLOW STEADY PULSE. FURTHER ACTIONS WILL REMOVE ANY HANDSET PAIRING.

Release the - and + buttons and within 1 second press the  Power Button on the Control Box.

The handset emits a short beep, the green light on the handset flashes and the following icon is displayed.



With the display showing the icon press and hold the SET button to pair the handset to the appliance.

Following new pairing it will be necessary to set the time and date, see Installation Instructions.

If too much time passes without the SET command the display will show the following.



The handset has not paired and the process will need to be started again.

SERVICING REQUIREMENTS/ FAULT FINDING CHARTS

IMPORTANT – Check the glass panel on this appliance for any signs of damage on the glass panel (scratches, scores, cracks or other surface defects). If damage is observed, the glass panel must be replaced and the appliance must not be used until a replacement is installed.
DO NOT USE the appliance if any damage is observed.
 Isolate the appliance until a replacement has been obtained and installed. Purchase replacement glass panels from Onyx via the retailer from which the appliance was purchased or any other Onyx distributor.

This appliance must be serviced at least once a year by a competent person.

All tests must be carried out in accordance with the current Gas Safe recommendations.

BEFORE TESTING:

- Conduct a gas soundness test for the property ensuring there are no leaks before servicing.
- Check the operation of the appliance before testing.

SPECIAL CHECKS:

- Clean the burner using a vacuum cleaner with a soft brush attachment. Ensure all debris is removed from the burner ports.
- Clean away lint or fluff from the pilot.
- Clean away lint or fluff from under the burner.
- Check the spark gap on the pilot is correct.
- Ensure that the glass frame is secured correctly and that all retaining screws are in place.

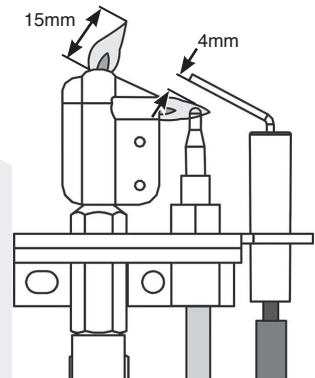

Correct any faults found during the initial test.

Re-commission the appliance in accordance with Commissioning Procedures.

Advise the customer of any remedial work undertaken.

IGNITION FUNCTIONAL CHECK 1

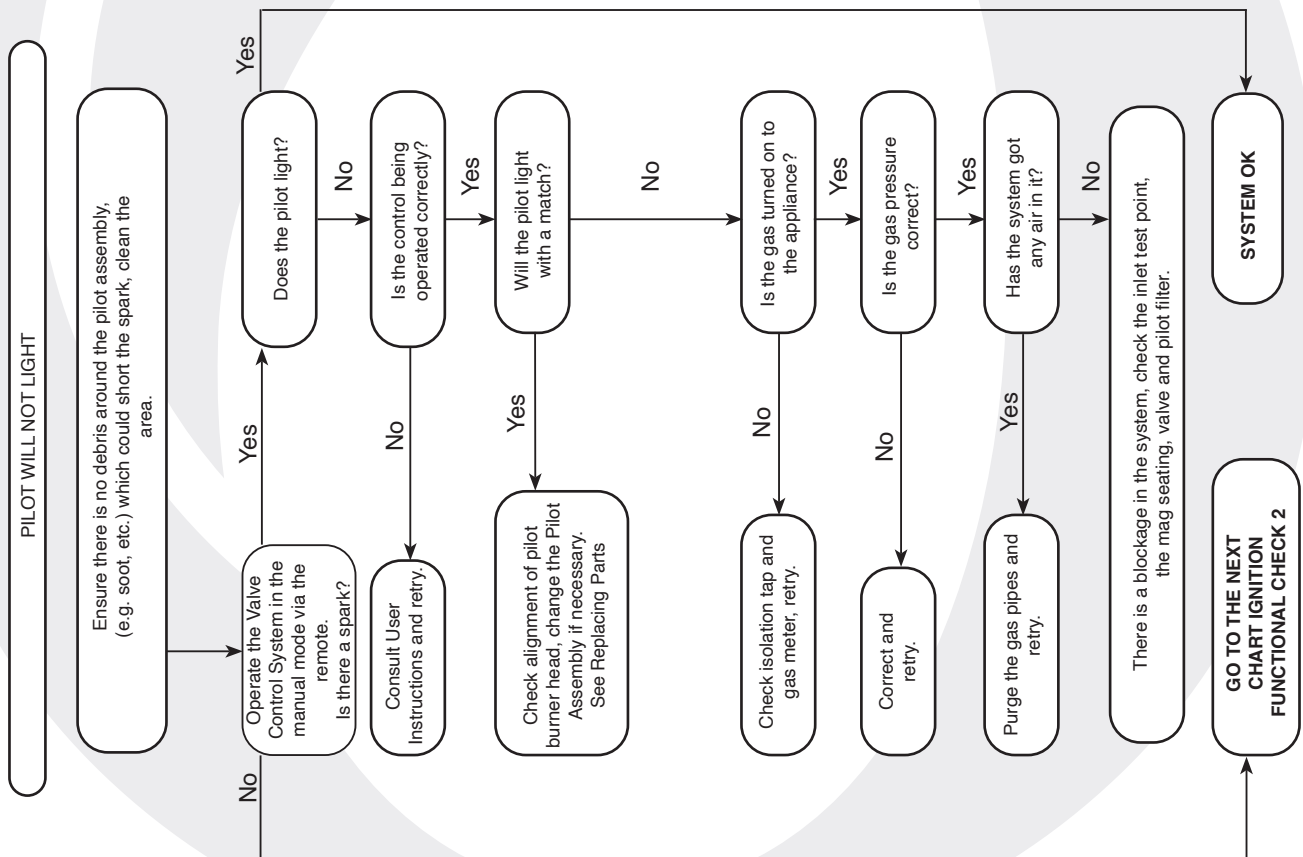

FAULT FINDING CHARTS

FLAME FAILURE FUNCTIONAL CHECK 3

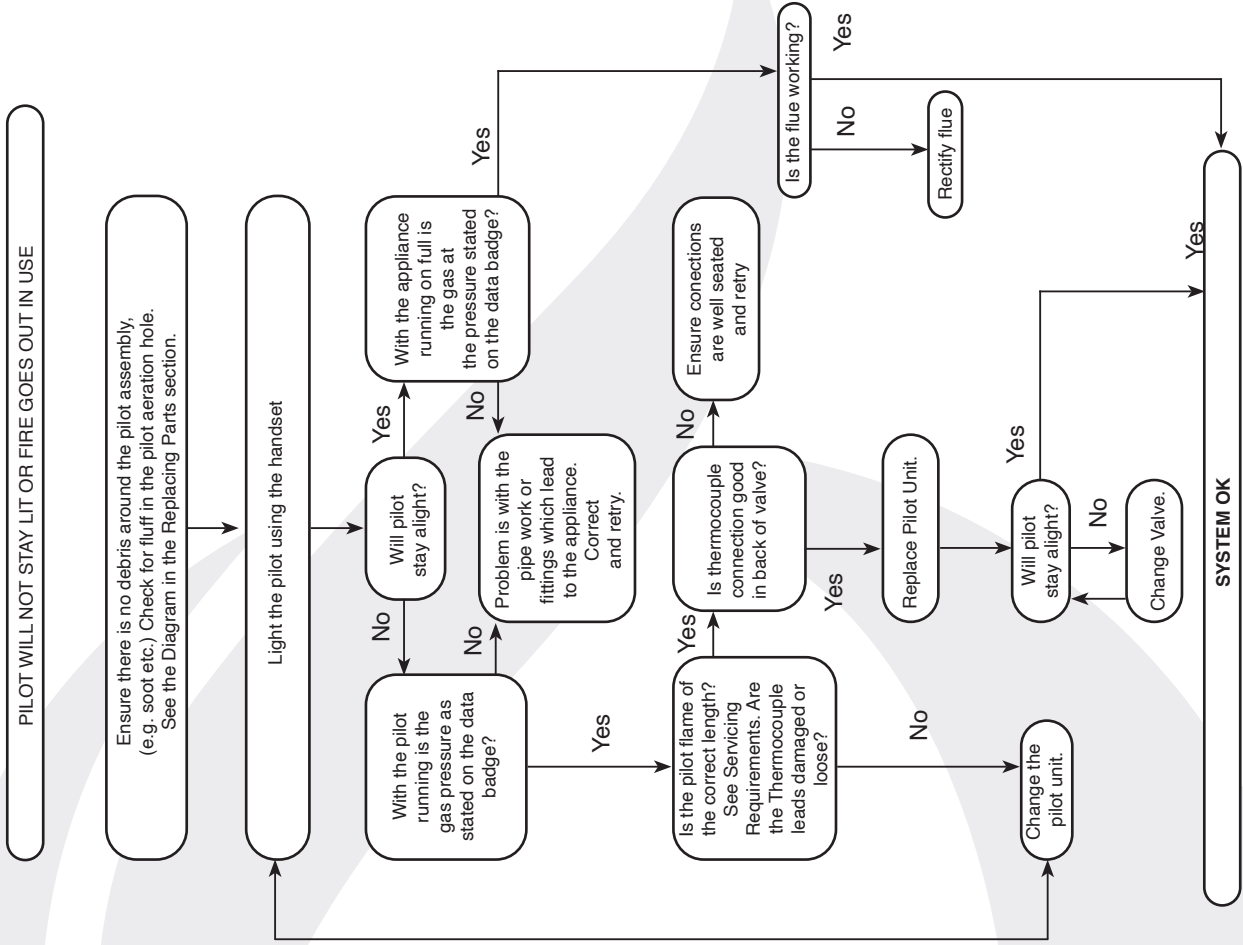

IGNITION FUNCTIONAL CHECK 2

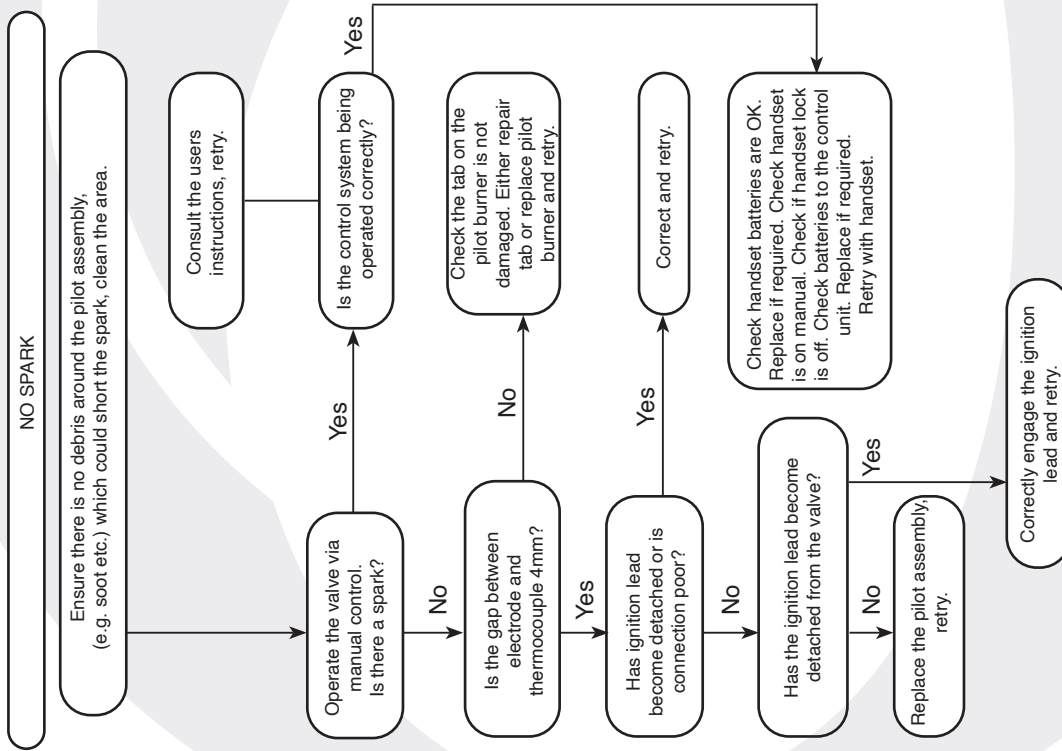

ELECTRONIC CONTROL VALVE FAULT ANALYSIS

RED INDICATOR	MEANING
Permanently Lit	Valve tried to light but failed and in LOCKOUT E00
Flashing very fast	Valve is busy (will not accept any command)
Flashing once a second	Valve detects an error
Flashing once every 10 seconds	Indication of low battery power in valve
Flashing twice every 10 seconds (handset only)	Indication of low battery power in handset and valve
Permanently off	Valve in standby or in a stable operation
On momentarily after power up	Valve doing a self test
Appears after pressing start	Indicates time to release pressing the start button

If the valve indicates an error:

Allow the appliance to cool (if hot).

Check the battery status and replace with new if in any doubt.

Reset the error by first pressing the power button (with the appliance cool).

Press once again to start the fire.

If the error repeats refer to the error code table below.

Error Code	Meaning
E00	Valve Locked due to failed ignition.
E01	Indicates that possibly the content of CO is too high in ambient atmosphere.
E02	Ambient temperature around Gas valve in the fire too hot (exceeded 72°C).
E03	Thermocouple connection to valve issue. Incorrect reading from thermocouple.
E04	Flame detected on pilot after valve has shutdown.
E05	Flame detected on pilot before valve has started.
E06 & 07	Occurs when supply voltage is too low to operate the valve.
E24	Occurs when thermocouple does not reach its final temperature within 1 minute.

SERVICING INSTRUCTIONS

All main components can be replaced without removing the appliance from its installation.

IT IS ESSENTIAL THAT THE GAS SUPPLY TO THE APPLIANCE IS TURNED OFF AT THE ISOLATION DEVICE BEFORE PROCEEDING FURTHER.

SERVICING AND SUPPORT



Servicing and Support

To keep your appliance looking and performing at its best, it must be serviced annually. This service must be undertaken by a suitably qualified individual and your retailer can organise this for you. Alternatively, Onyx offer a manufacturers premium service with our friendly team of qualified engineers which can be booked at www.onyxfires.com/support

REMOVING THE GLASS FRAME

Remove the glass door by removing the 2 side trims. These are held on by magnets.

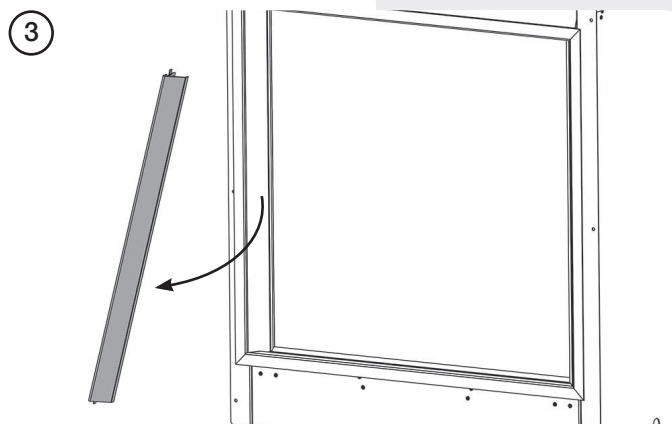
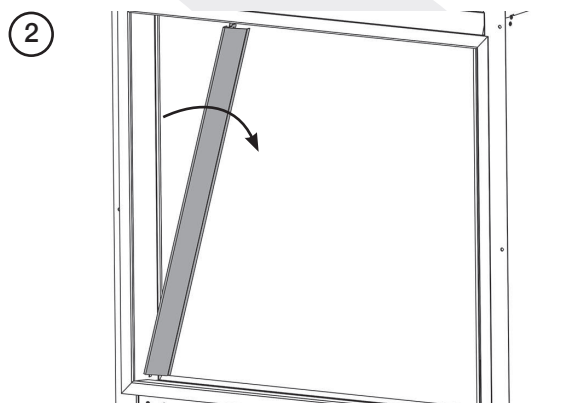
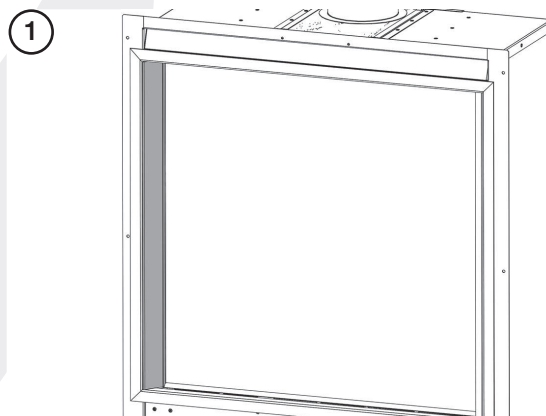
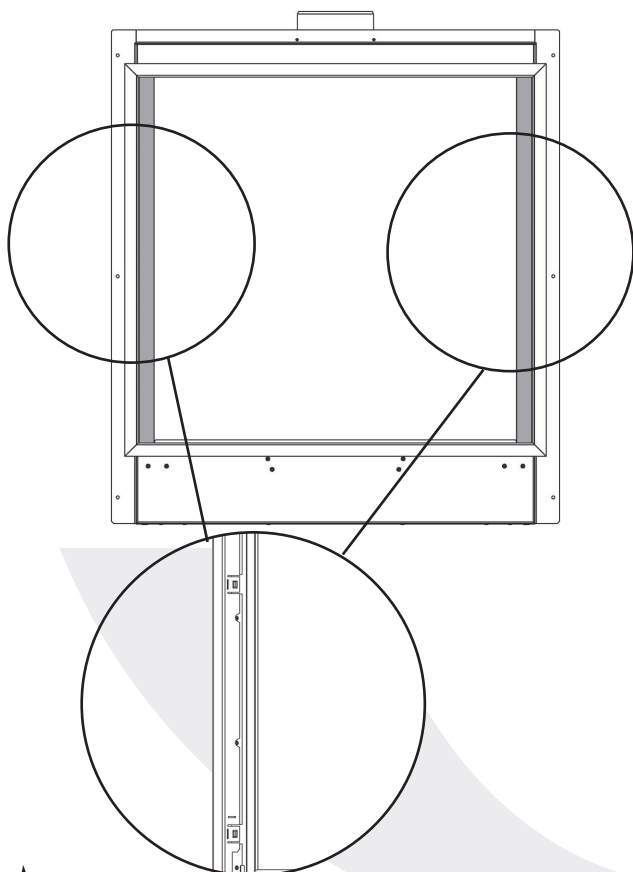

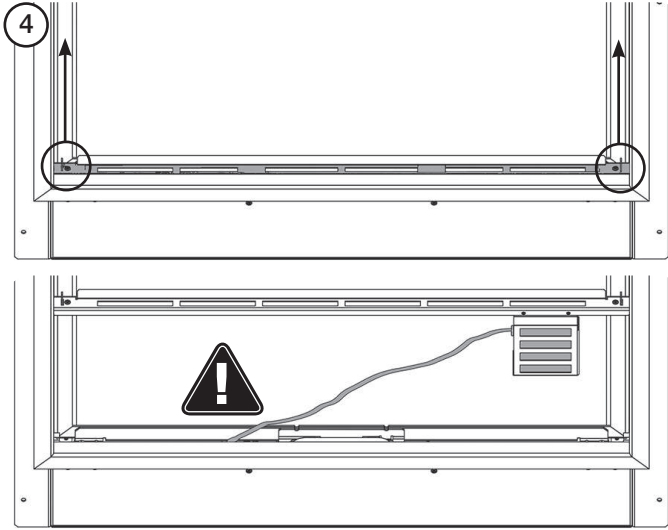

i The Battery Box cannot be disconnected from the Gas Valve at this stage.
DO NOT STRETCH THE WIRE.

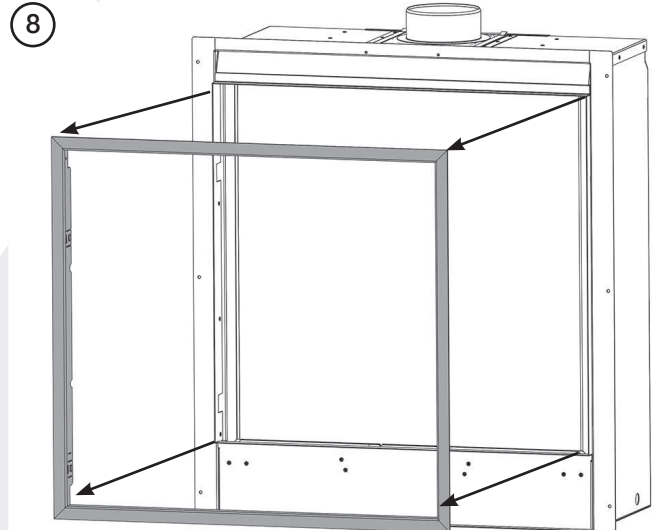
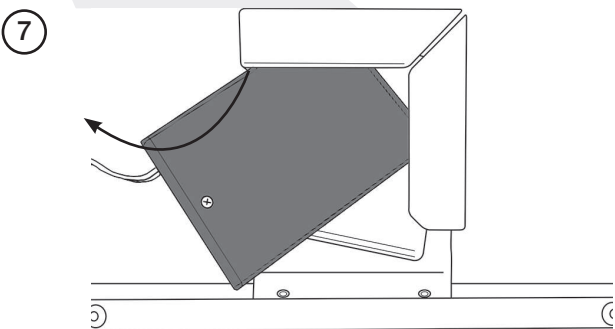
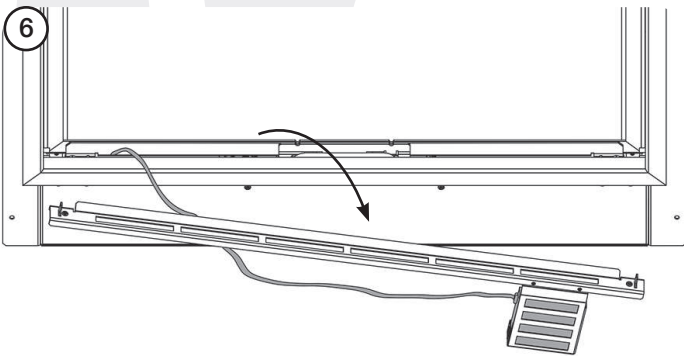
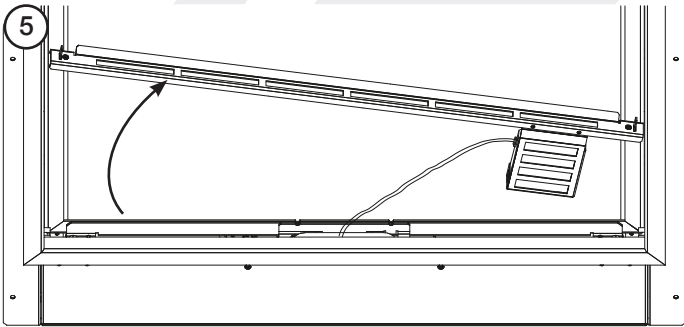

(Edge Plus Frame only)

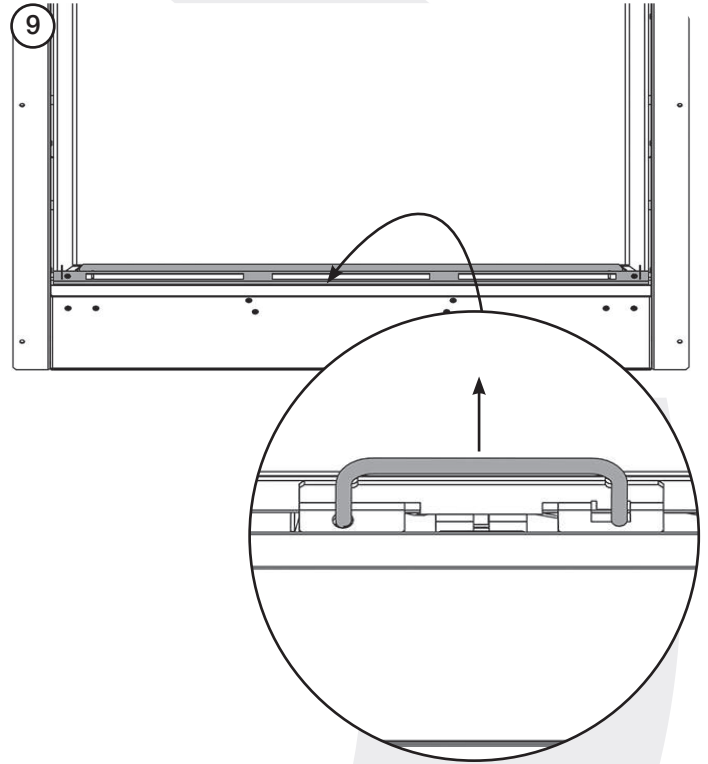

11

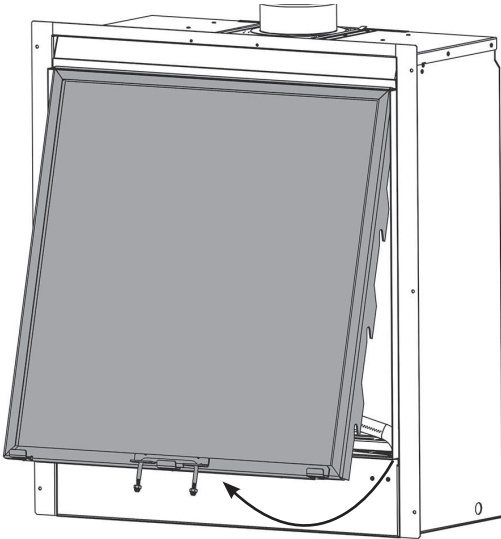

12

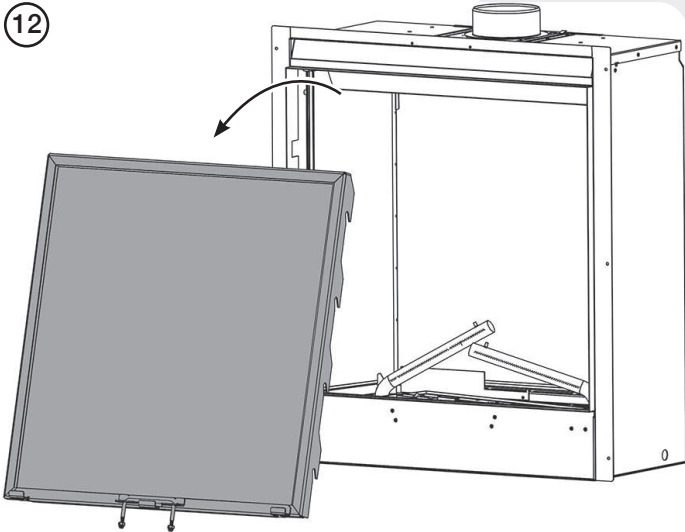

REMOVING THE BURNER ASSEMBLY

1

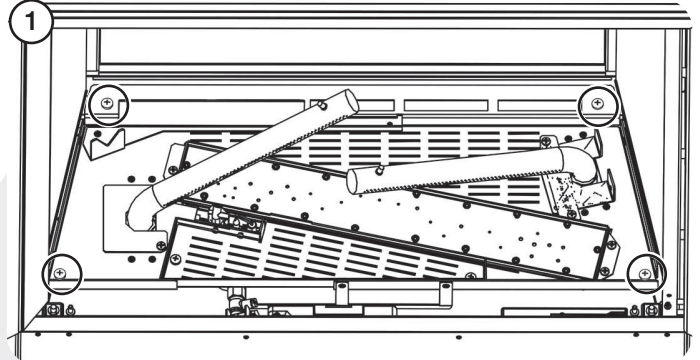

2

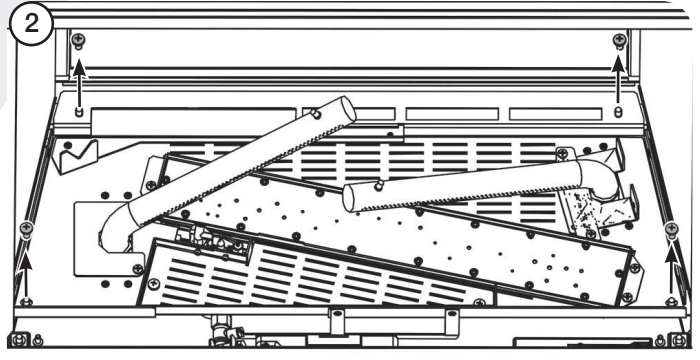

3

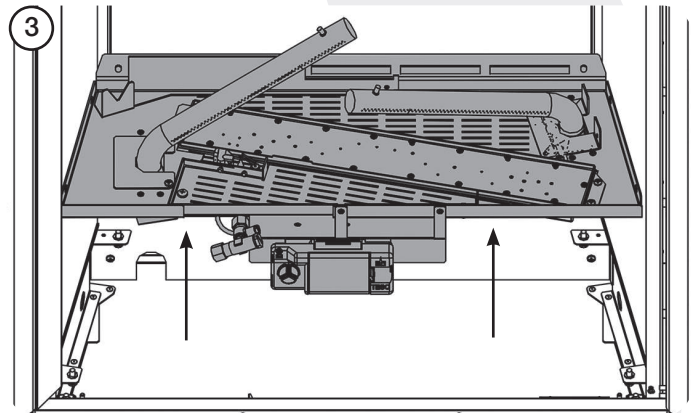

IMPORTANT: REFER TO DATA BADGE AND TECHNICAL SPECIFICATION AT THE FRONT OF THE MANUAL TO ENSURE THE APPLIANCE IS CORRECTLY ADJUSTED FOR THE GAS TYPE AND CATEGORY APPLICABLE IN THE COUNTRY OF USE.

Replace in reverse order.

ODS PILOT UNIT



IMPORTANT: UNDER THE TERMS OF THE EXTENDED WARRANTY IT WILL BE COMPULSORY TO CHANGE THE COMPLETE PILOT UNIT ON THIS APPLIANCE IN YEARS 2 AND 4.

Note: The pilot unit on the appliance is a non serviceable unit due to the complex nature of its manufacture.

Replacement of the complete unit must be carried out when one of the following items becomes faulty:

- Pilot injector
- Ignition electrode
- Thermocouple leads
- Ignition Lead

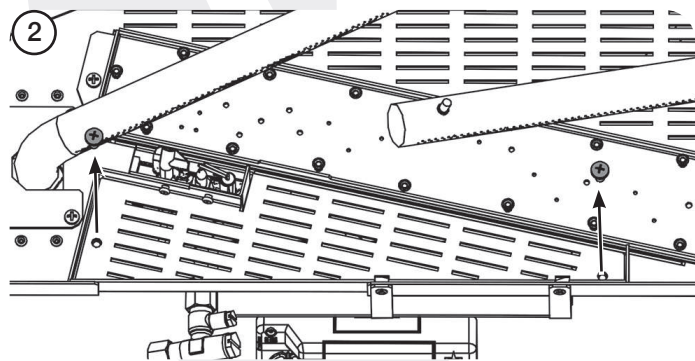
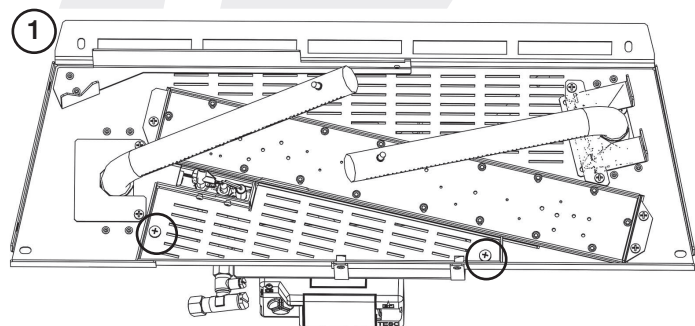
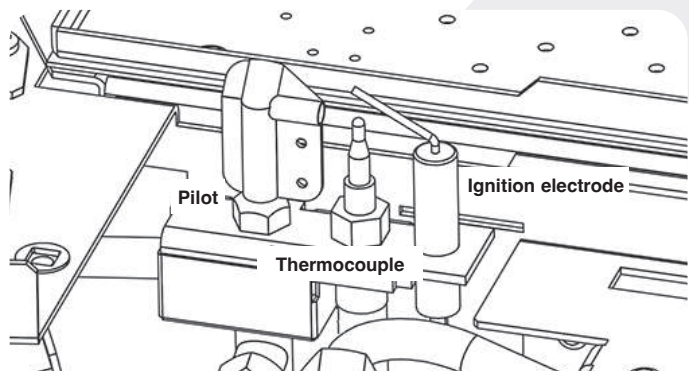

Undo the pilot pipe from the pilot unit

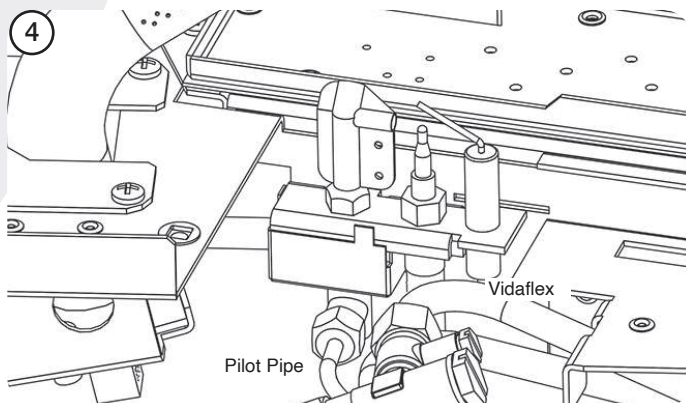
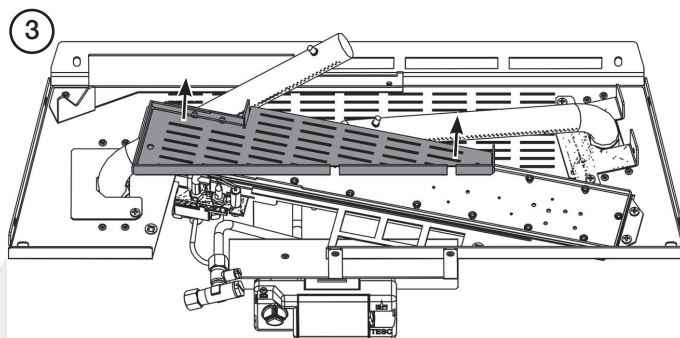

Unplug the red and green thermocouple connections (A) and the white ignition lead (B) from the gas valve.

NOTE: Ensure the correct orientation when replacing.

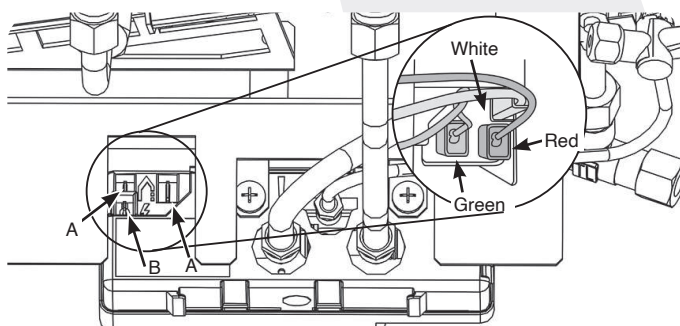

Replace with a new pilot assembly and check the spark gap.

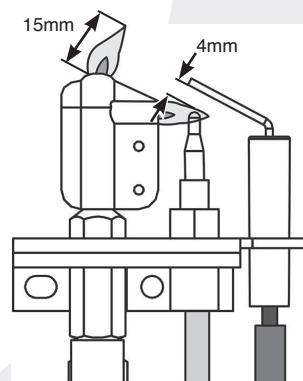

NOTE: Ensure the correct orientation when replacing.

After reassembly check for gas soundness and carry out a functional check.

IGNITION LEAD

The Ignition Lead used on this appliance can not be replaced individually. If a new lead is required it will be necessary to change the Pilot Unit.

GAS VALVE



IMPORTANT: TURN OFF THE GAS SUPPLY AT THE ISOLATION DEVICE.

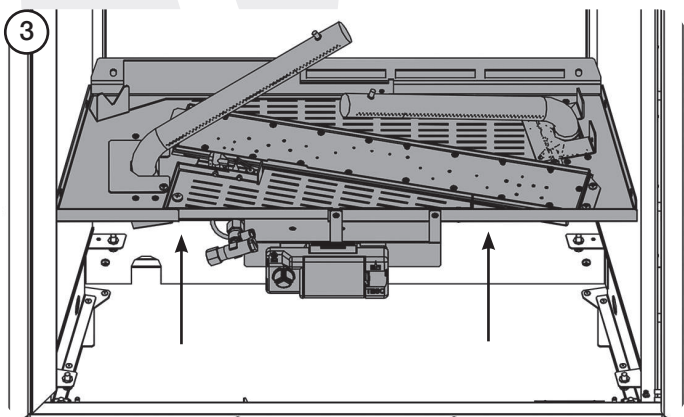
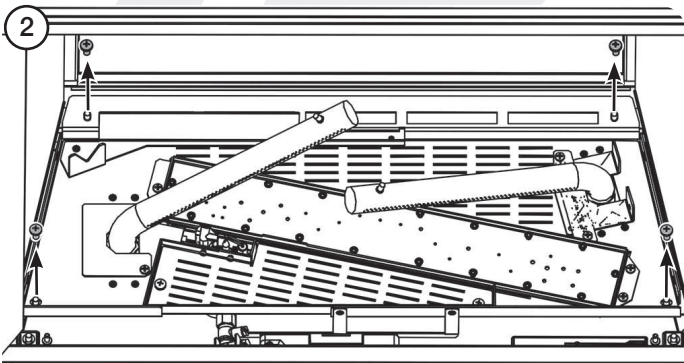
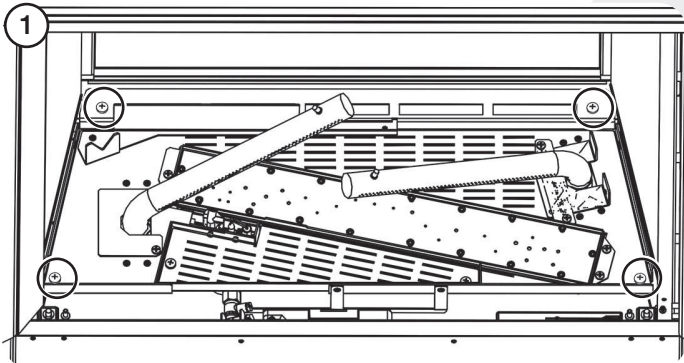

4

Battery Holder
Connection Lead

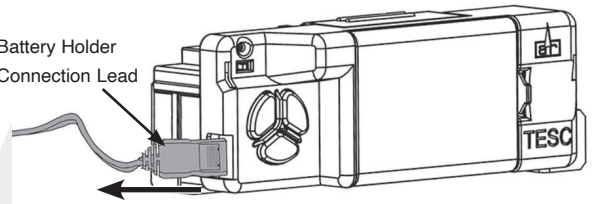

Unplug the red and green thermocouple connections (A) and the white ignition lead (B) from the gas valve.

NOTE: Ensure the correct orientation when replacing.

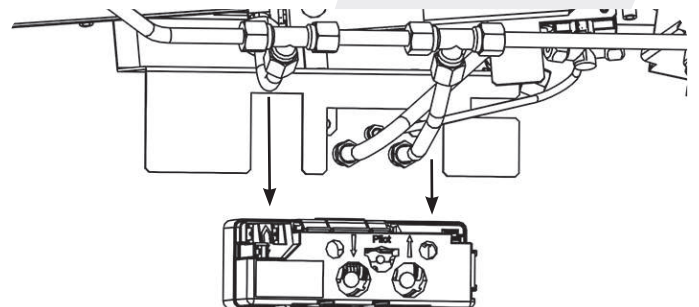
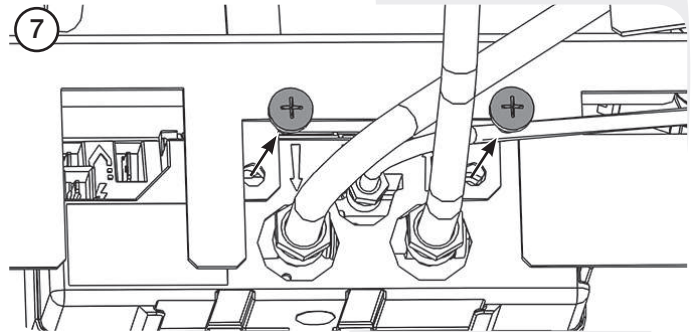
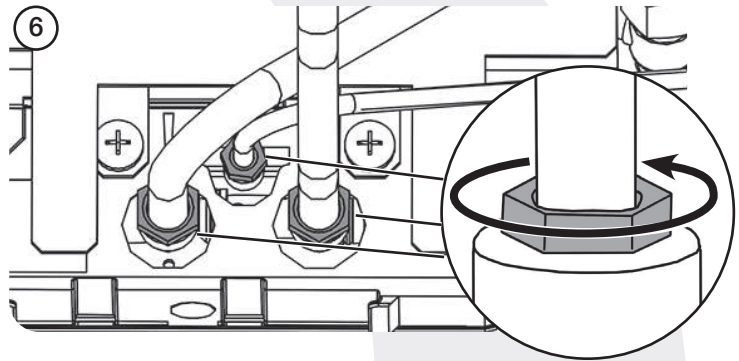
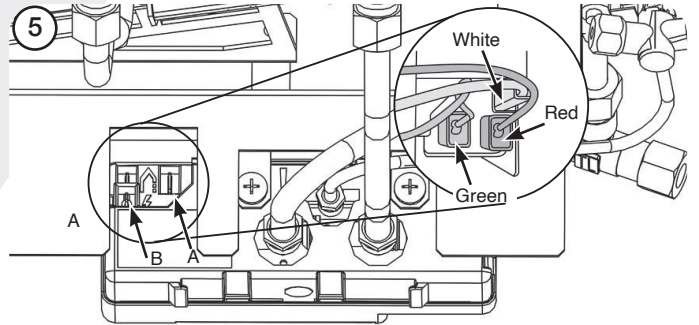

Replace in reverse order.

Check all joints for gas leaks and check operation of the thermocouple and ignition lead.

MAGNETIC SAFETY VALVE

The Magnetic Safety Valve used on this appliance is a non serviceable part of the Control Valve and will require complete replacement.

INJECTORS



IMPORTANT: TURN OFF THE GAS SUPPLY AT THE ISOLATION DEVICE.

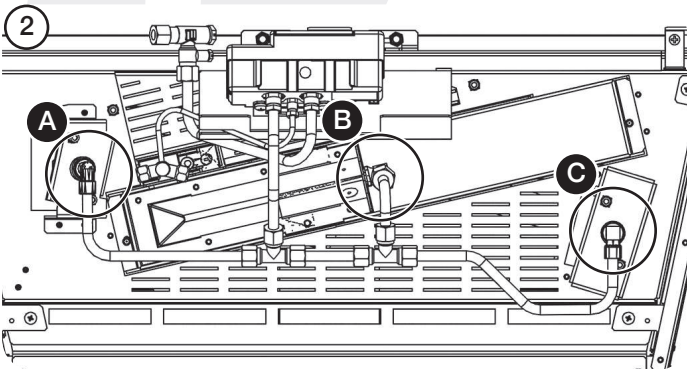
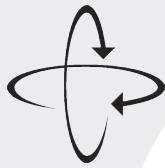
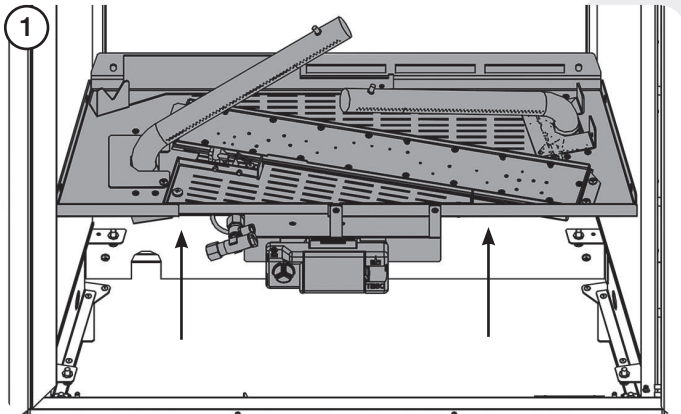

Holding the injector with a spanner:

- Undo the feed pipe. **Note the orientation of the Injector.**
- Re-assemble in reverse order.

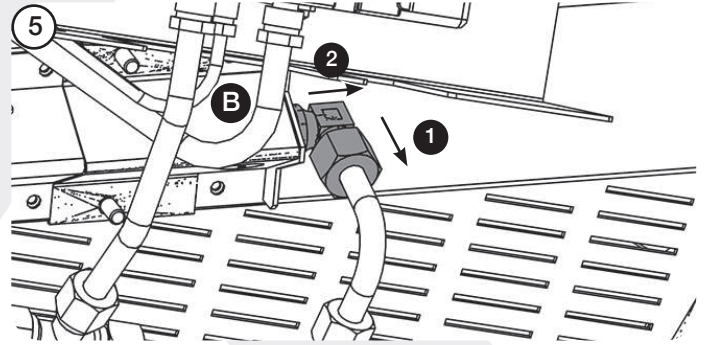
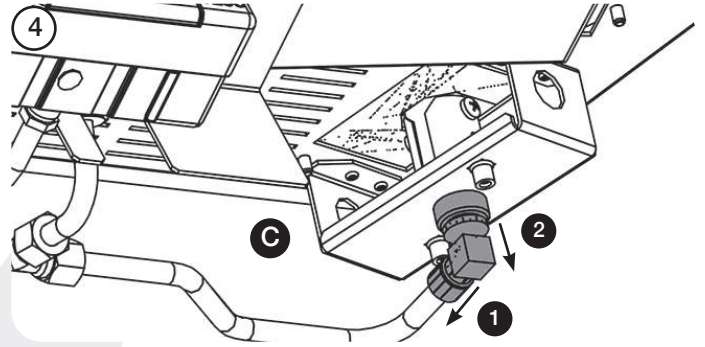
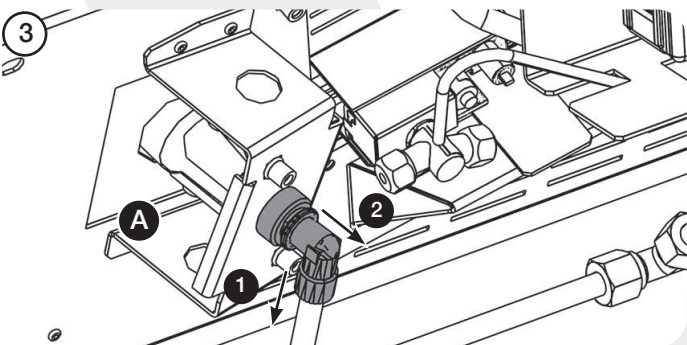

Turn on the gas supply and check for leaks.

PRIMARY AERATION PLATE



NOTE: Not all models have aeration plates. Please refer to the Technical Specification.



IMPORTANT: TURN OFF THE GAS SUPPLY AT THE ISOLATION DEVICE.

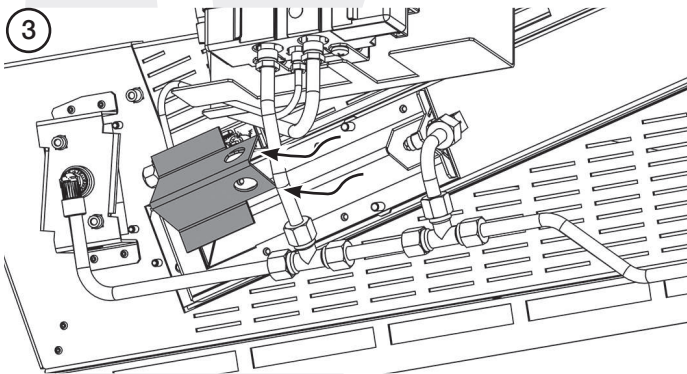
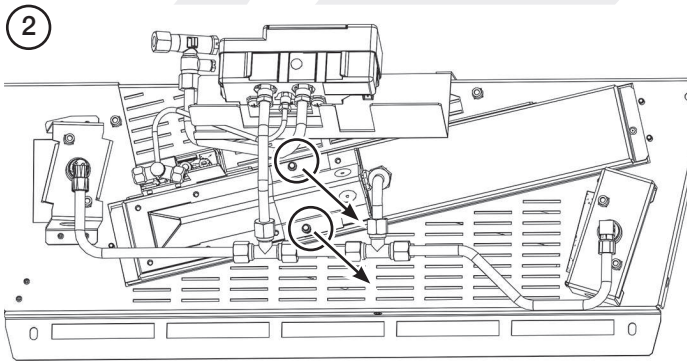
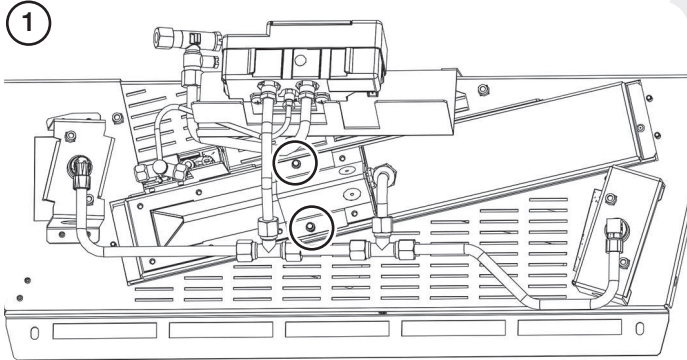

Replace with the correct size plate and secure the 2 nuts. Ensure that the lower edge of the plate is located over the venturi flange.

BURNERS & BURNER AERATION

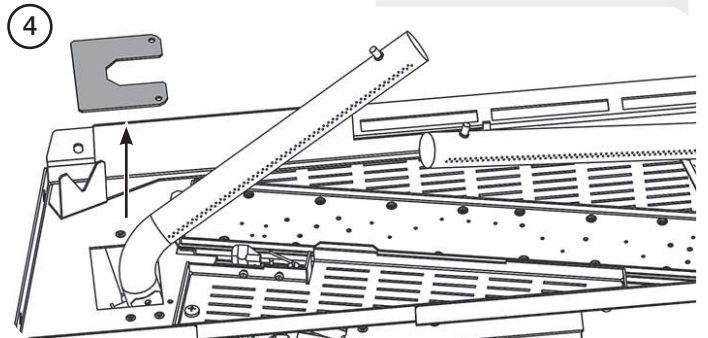
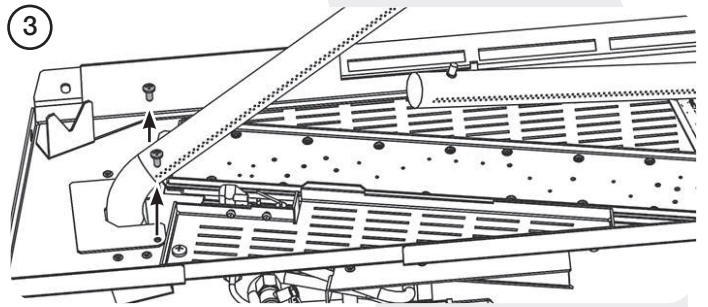
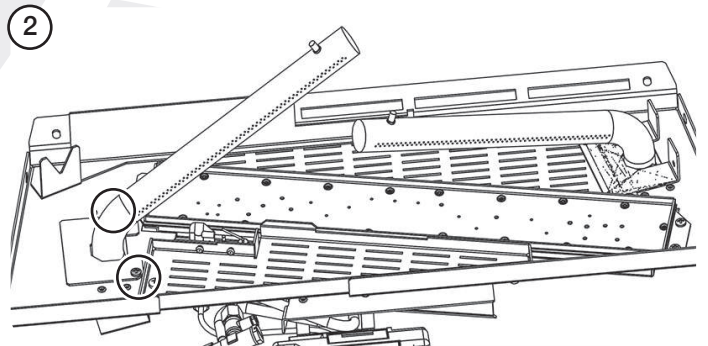
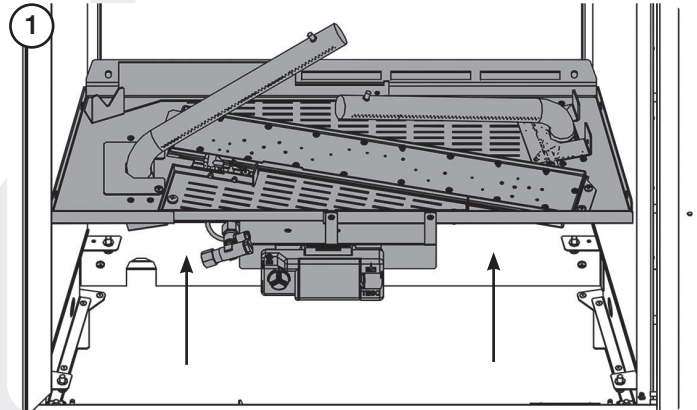

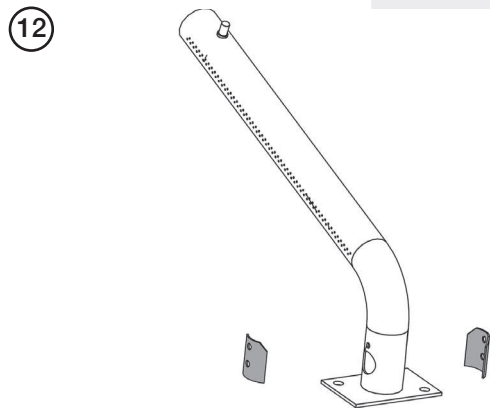
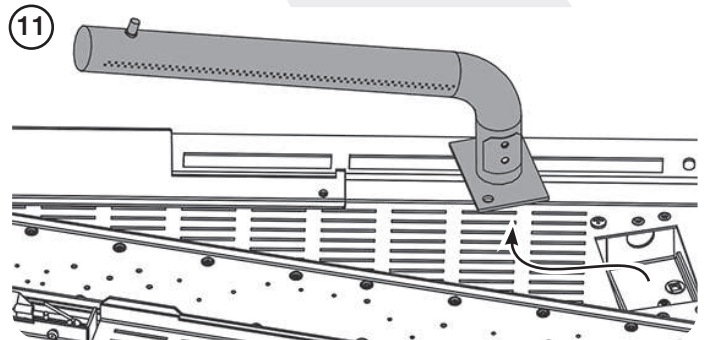
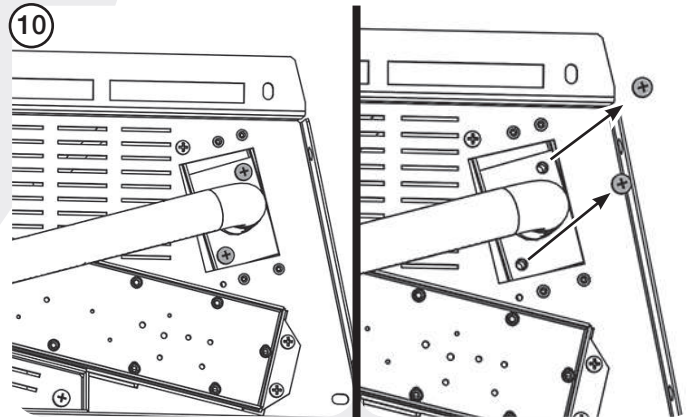
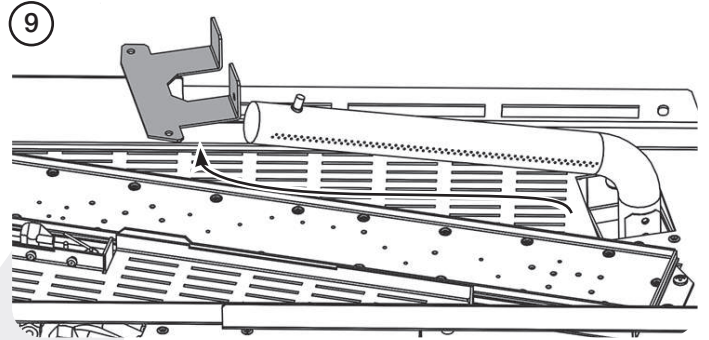
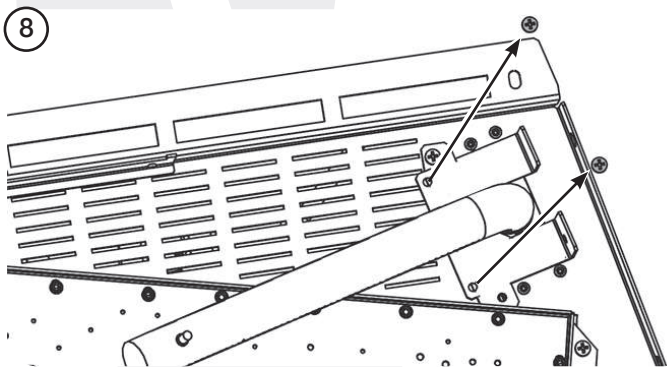
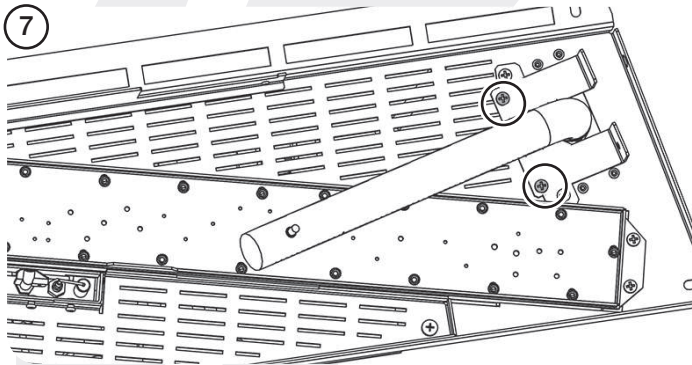
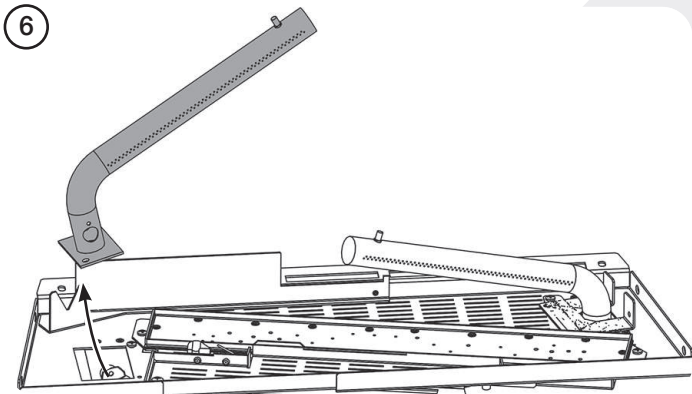
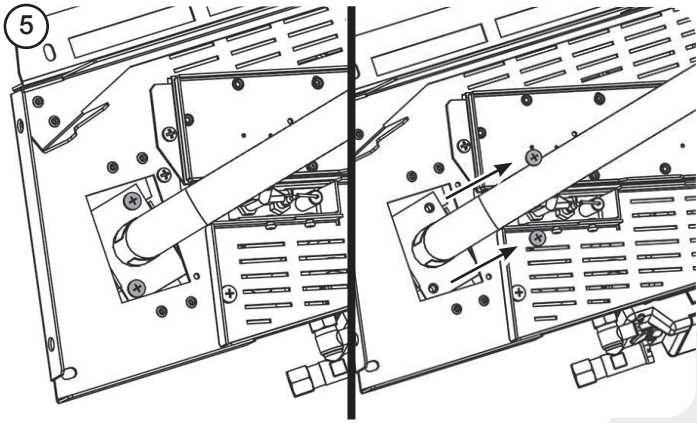

BAFFLE & LINERS

BAFFLE

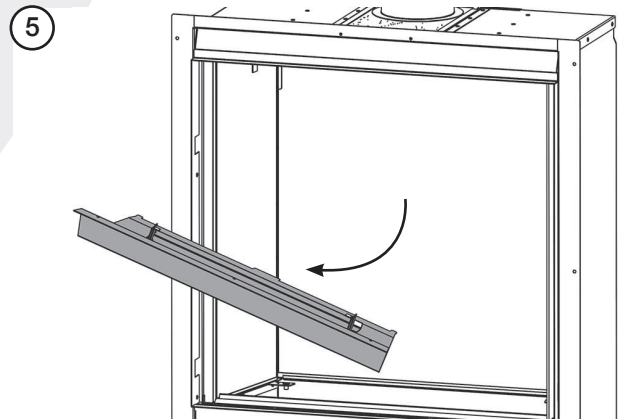
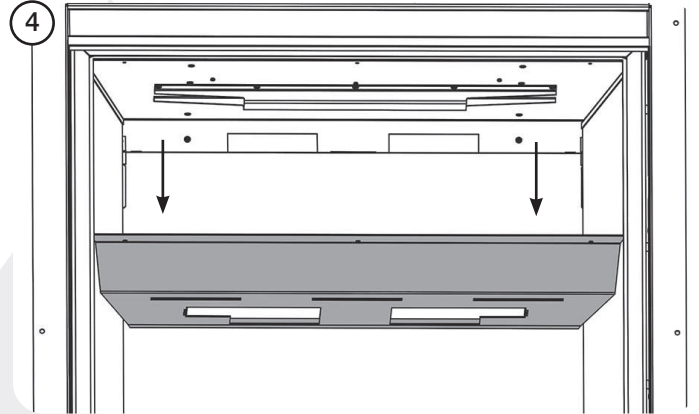
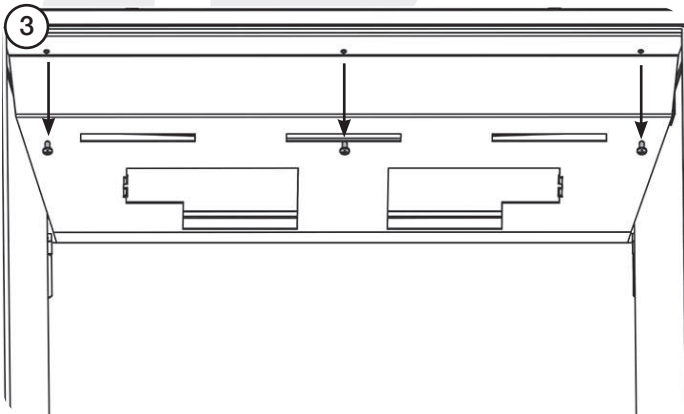
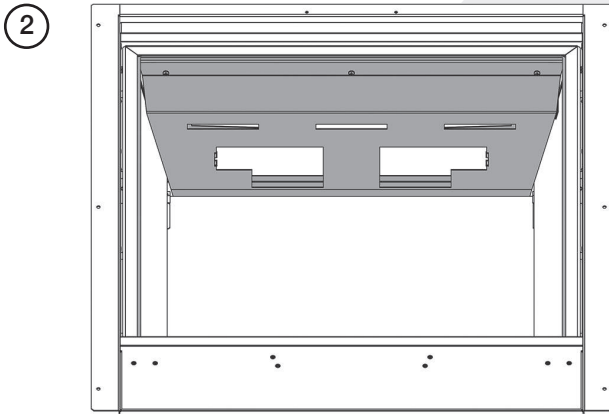
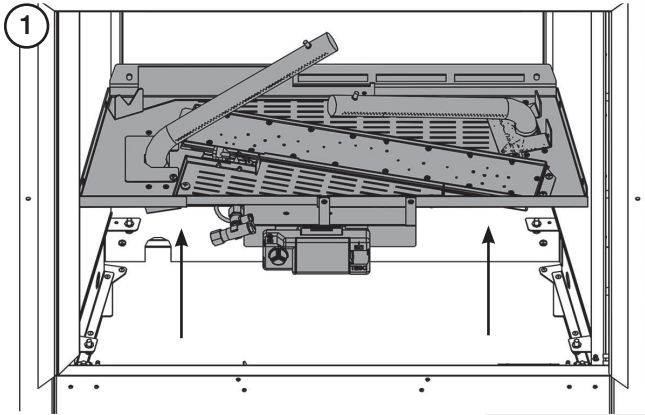

LINERS

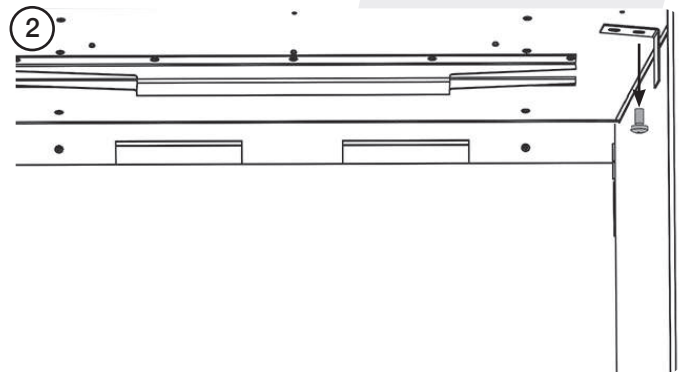
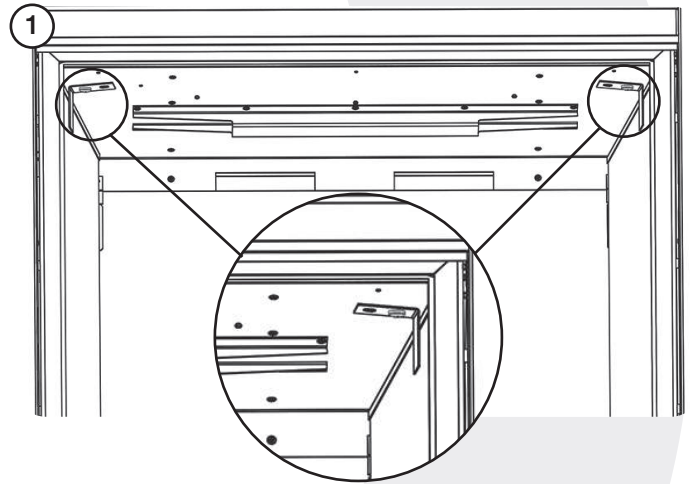

onyx

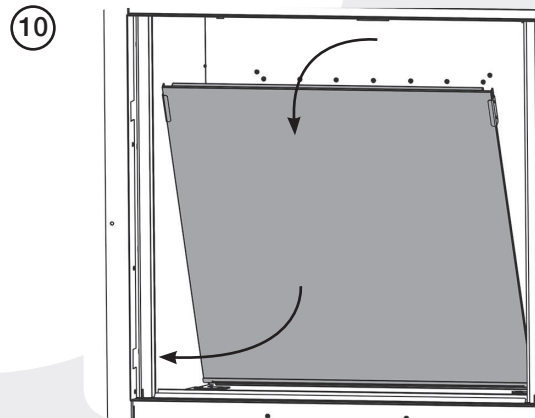
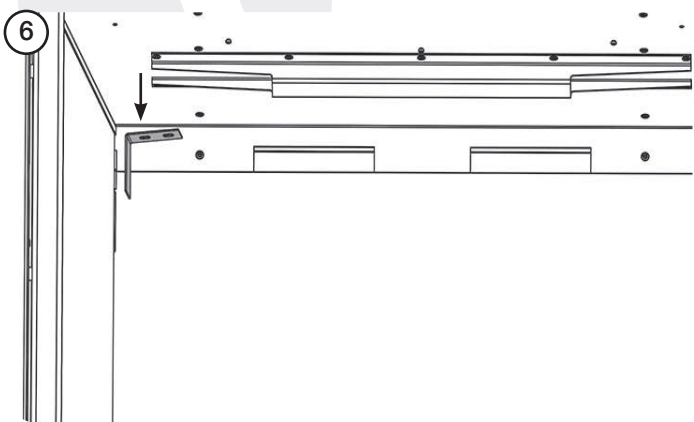
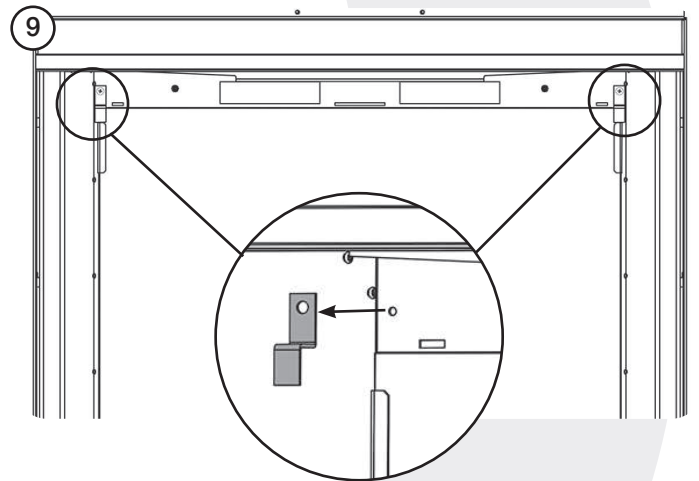
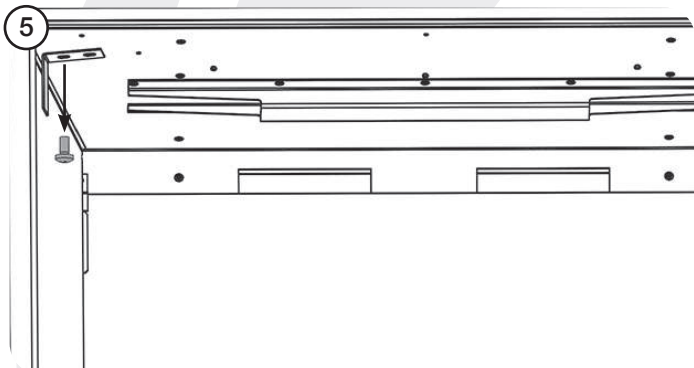
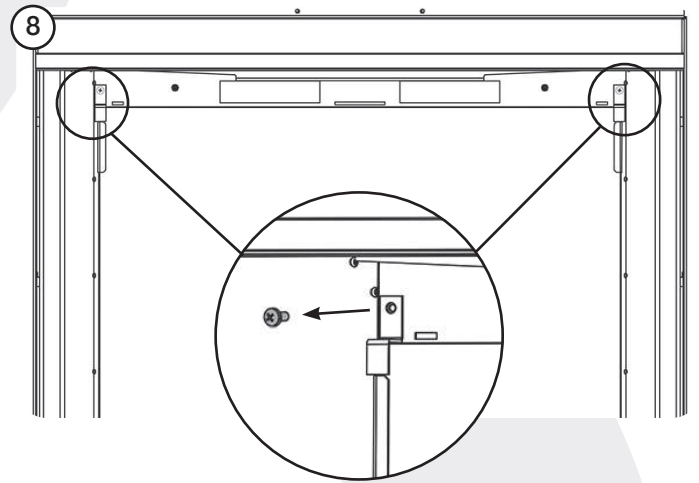
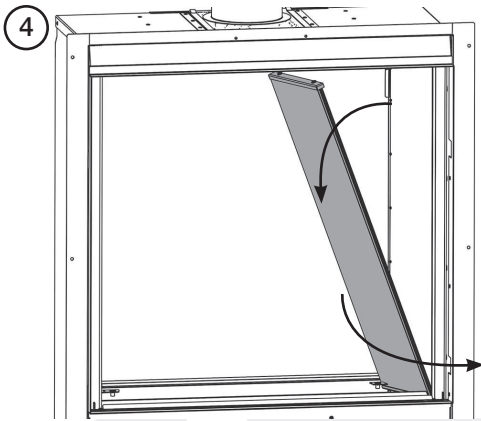
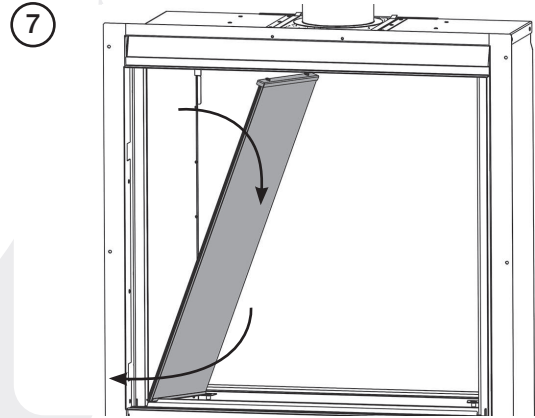
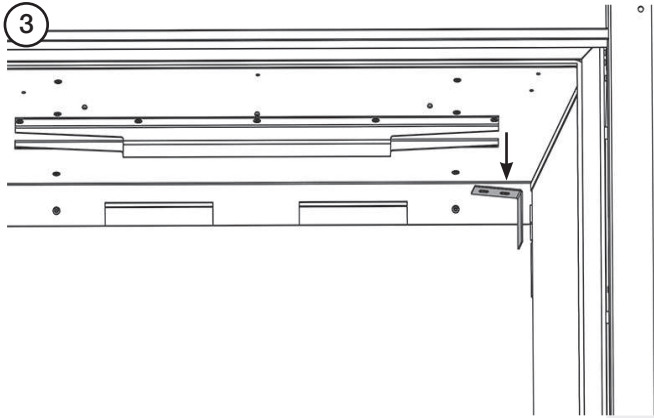

PRODUCT MATERIAL INFORMATION

The following substances, preparations or components should be disposed of or recovered separately from other WEEE in compliance with Article 4 of EU Council Directive 75/442/EEC.

Metal	Steel	Can be taken to a local recycling centre for reuse to reduce waste going to landfill.
	Cast iron	
Glass		Can be taken to a local recycling centre for reuse to reduce waste going to landfill.
Rope seals/ Coal Fuel Effects/ Brick Effect, Ledgestone and Black Reed Liners		If the product contains any of the following: Rope seals, Coal Fuel Effects, Black Reed Brick Effect or Ledgestone Linings panels these items are made from Refractory Ceramic Fibre (RCF), a material which is commonly used for this application. Protective clothing is not required when handling these articles, but it is recommended to follow normal hygiene rules of not smoking, eating or drinking in the work area and always wash hands before eating or drinking. When servicing the appliance it is recommended that the replaced items are not broken up, but are sealed within heavy duty polythene bags and labelled as RCF waste. RCF waste is classed as stable, non-reactive hazardous waste and may be disposed of at a licensed landfill site.
Log Fuel Effects		Log Fuel effects are not considered hazardous to health, but are non-recyclable and must be disposed of in accordance to the rules in force.
Electrical components	(Fan kits etc if applicable)	Dispose of at a local recycling centre in accordance with the WEEE directive.

INFORMATION REQUIREMENT FOR GASEOUS FUEL LOCAL SPACE HEATER

Model		ECLIPSE 60HL NG	ECLIPSE 60HL LPG
Fuel	Space Heating Emissions (NOx) - mg / kWh _{input} (GCV)	130	130
Heat Output	Nominal Heat Output - P_{nom}	5.1	4.9
	Minimum Heat Output (indicative) - P_{min}	3.1	2.7
Auxiliary Electricity Consumption	At Nominal Heat Output - $e_{l_{max}}$	N/A	N/A
	At Minimum Heat Output - $e_{l_{min}}$	N/A	N/A
	In Standby Mode - $e_{l_{sb}}$	N/A	N/A
Useful Efficiency	Useful Efficiency at nominal heat output - $\eta_{th,nom}$	78	78
	Useful Efficiency at minimum heat output (indicative) - $\eta_{th,min}$	68	65.5
Pilot Flame Power requirement	Permanent Pilot Flame Power requirement (if applicable) - P_{pilot}	N/A	N/A
Type of heat output/room temperature control			
	Electronic room temperature control + day timer	Yes	Yes
Other control options (multiple selections possible)			
	Room temperature control, with presence detection	No	No
	Room temperature control, with open window detection	No	No
	With distance control option	No	No
	With adaptive start control	No	No
	With working time limitation	No	No
	With black bulb sensor	No	No
Energy Efficiency Index		74	74
Energy Efficiency Class		D	D
Contact:	Gazco Ltd, Osprey Road, Sowton Industrial Estate, Exeter, EX2 7JG		

SPARES LIST - MAIN ASSEMBLY

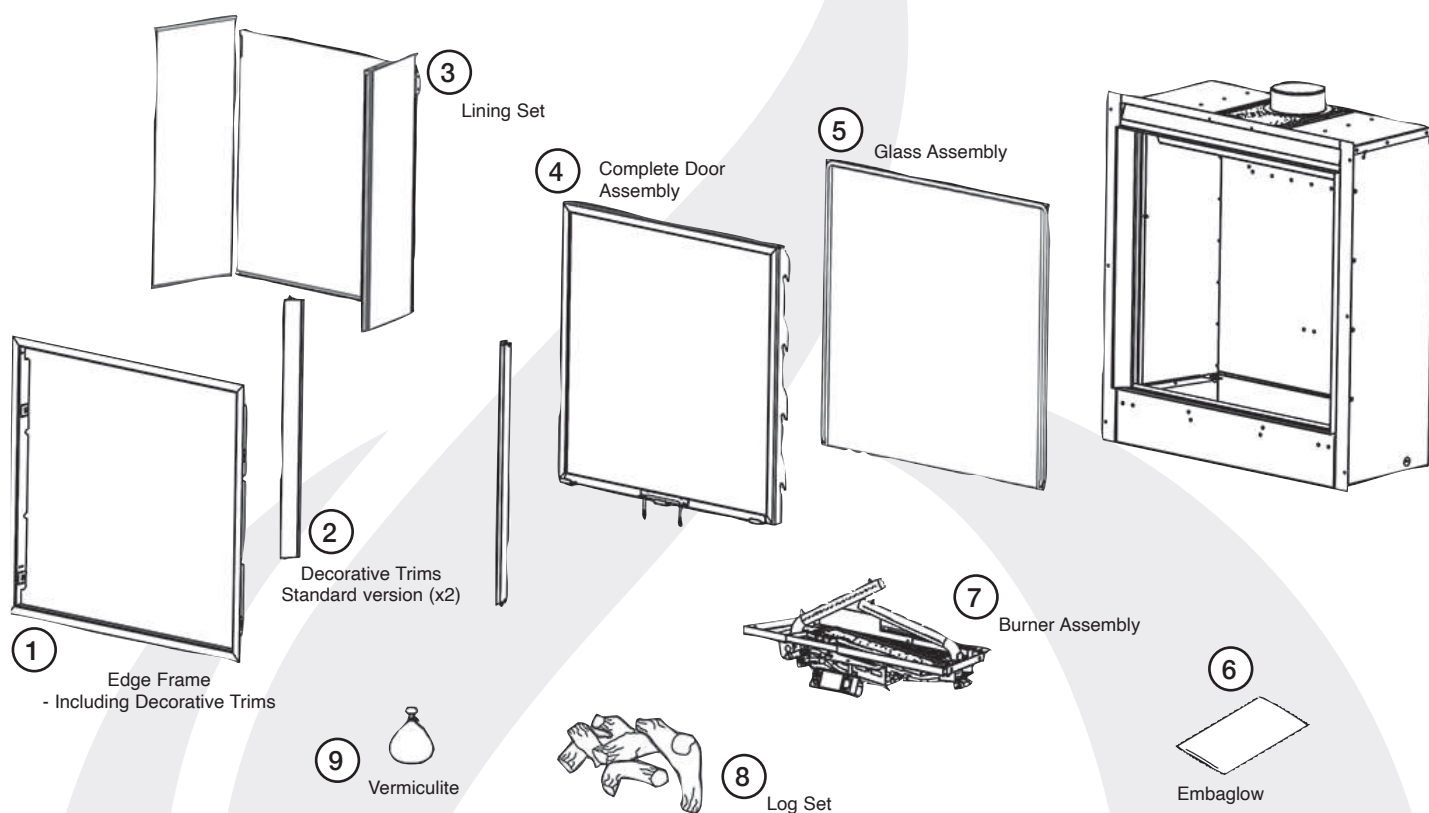

GAS TYPE	1	2	3	4	5	6	7	8	9
LPG	928-071	GZ14748 (x2)	934-600	GZ14746	GZ14728	GZ8471	GZ17084P	CE2151	CE2176
Nat. Gas							GZ17084N		



Due to continual technical improvements please check online or with your Onyx retailer for the most up to date parts lists.

Only use Genuine Onyx spares when servicing your appliance.

All of our essential spare parts and consumable items are available to purchase from our webshop at www.onyxspares.com.

SPARES LIST - CONTROL ASSEMBLY

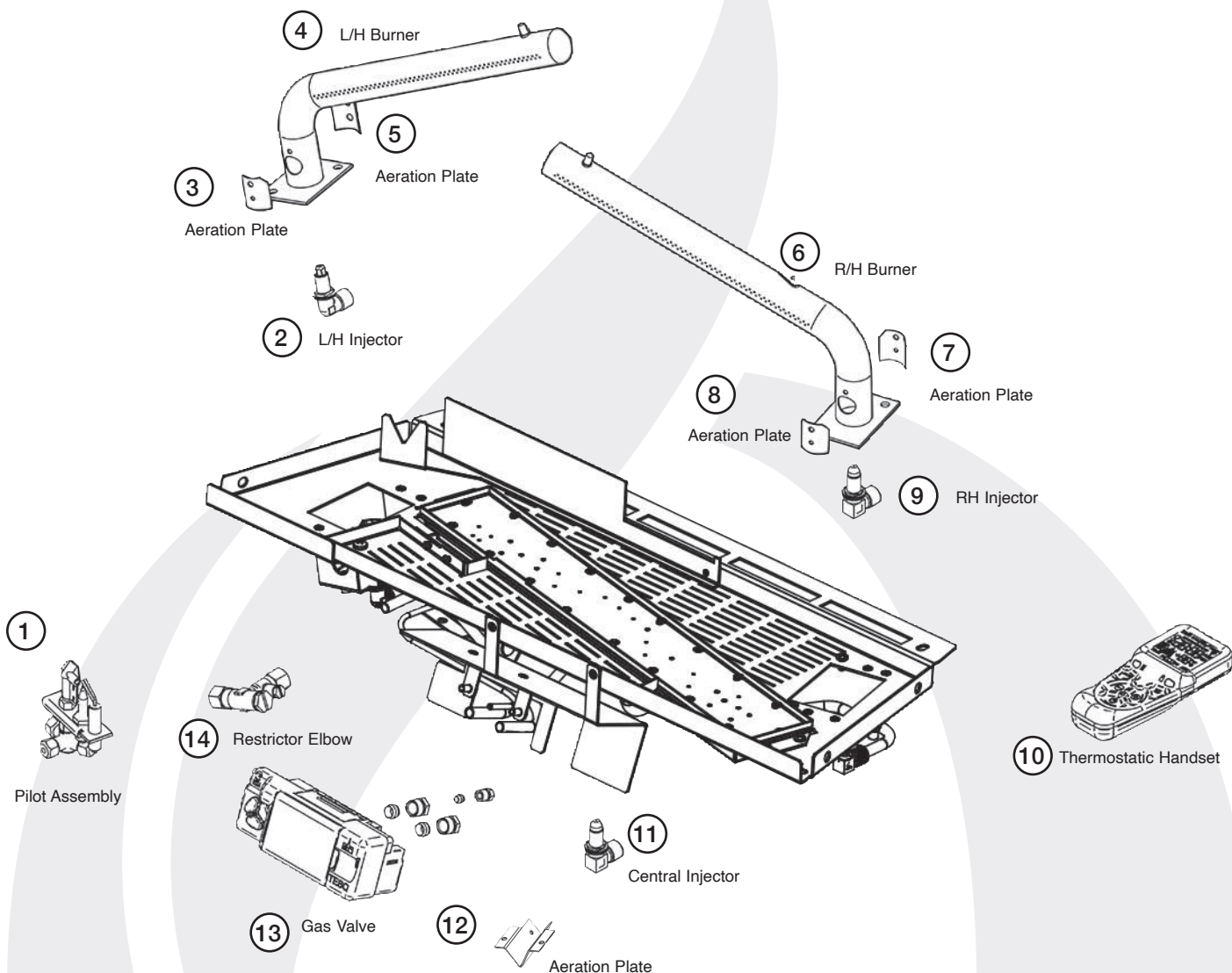

GAS TYPE	1	2	3	4	5	6	7	8	9	10
LPG	PI0092	IN0111	-	GZ16487	-	GZ16487	-	-	IN0111	EL0898
Nat. Gas	PI0090	IN0058	GZ17115		GZ17115		-	GZ17113	IN0110	

GAS TYPE	11	12	13	14
LPG	IN0102	GZ10410	GZ0182K	GC0095
Nat. Gas	IN0065	GZ10404		



Due to continual technical improvements please check online or with your Onyx retailer for the most up to date parts lists.

Only use Genuine Onyx spares when servicing your appliance.
All of our essential spare parts and consumable items are available to purchase from our webshop at www.onyxspares.com.



FOR ENQUIRIES IN THE U.K (EXCLUDING NI):

Onyx Limited, Spitfire Avenue, Skypark, Clyst Honiton, Exeter, Devon, England EX5 2FR

Tel: (01392) 474011 E-mail: info@onyxfires.com

FOR ENQUIRIES IN EUROPE (INCLUDING NI):

Stovax Heating Group (NI) Ltd (Comp reg NI675194), 40 Linenhall Street, Belfast, BT2

8BA DX 400 NR Belfast Tel: +44 (0)1392 261990 E-mail: northernireland@onyxfires.com

