

HEALTH & SAFETY FIRST



The handle is in the locked position. Before you can open the door, you must remove the grub screw – see below.

DO NOT TRY AND FORCE THE HANDLE OPEN

NOT TRY AND FORCE THE HANDLE OPEN

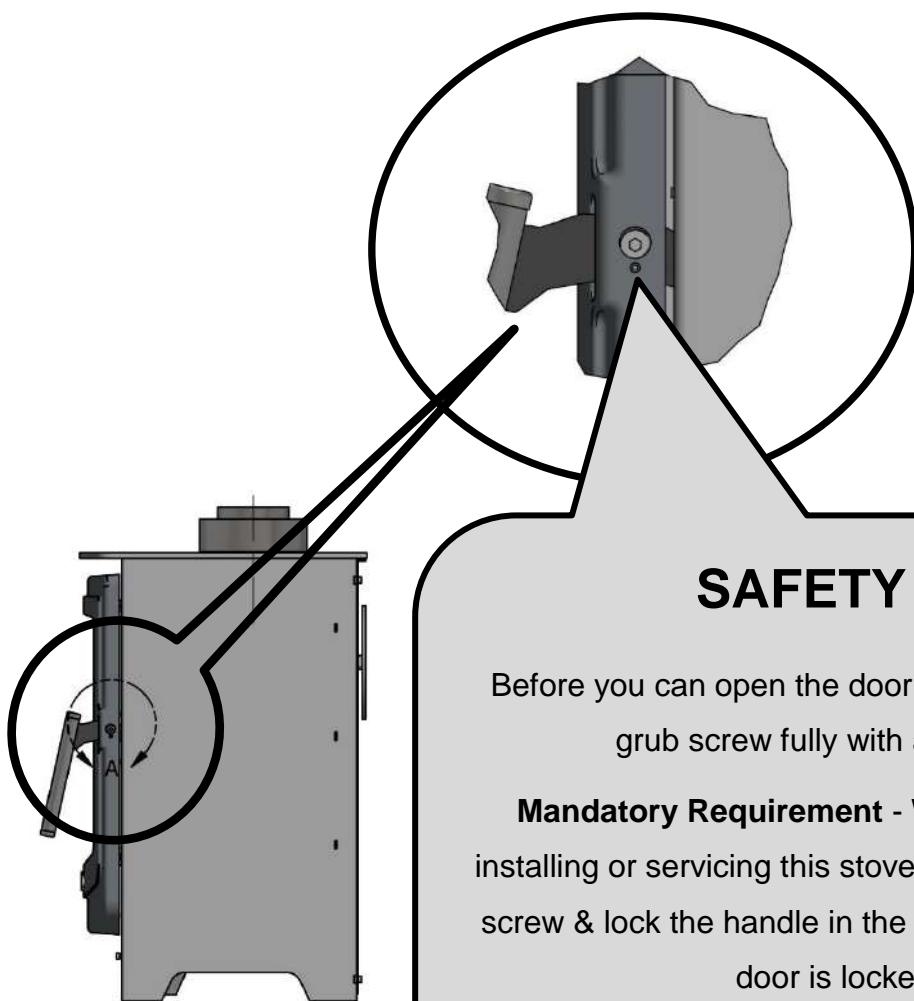

SAFETY FIRST

Before you can open the door you must remove this M4 grub screw fully with an M4 Allen Key.

Mandatory Requirement - When you have finished installing or servicing this stove you must replace the grub screw & lock the handle in the fully closed position so the door is locked closed

Only Gas Safe Engineers can remove this Grub screw

ELLESMERE & LUDLOW ECGW – Wide Model LPG Gas



ELLESMERE & LUDLOW ECGW

Wide ECGW Model
Balanced Flue Gas Stove
Fuel Type – LPG Gas

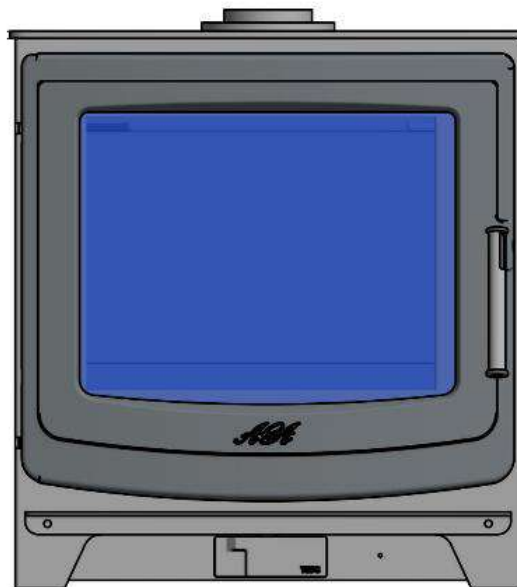

INSTALLATION, SERVICING AND USER OPERATING INSTRUCTIONS

For use in GB & IE (United Kingdom and Ireland)

Document No. : RH/TESS/SIN/BUR/NG - Iss 04/11/2020
File: Ellesmere & Ludlow LPG Gas ECGW _User_Man.doc

This Stove is –

FUEL Type: LPG Gas

Important Notice - *please read carefully*

This is a Mandatory Requirement the gas feed pipe to the rear/side of this stove must be a minimum of 15mm in diameter this will ensure the correct pressure and flow to the stove.

THIS STOVE AND FLUE SYSTEM MUST BE INSTALLED & COMMISSIONED BY A COMPETENT GAS SAFE REGISTERED PERSON ONLY FOR THE WARRANTY TO BE VALID

Mandatory Requirement for Installing & Commissioning this stove:

- 15mm diameter minimum gas feed pipe to this stove
- LPG Gas Inlet Pressure Must be at 37.5 Mbar
- Fitting of an ON/OFF Tap with a Pressure Test Point fitted to the side of this stove (this tap is not supplied with the stove)
- Rear Chain kit is fitted – full instructions in this stove
- Flue locking screws x 2 - fitted into the flue collar
- Door Handle Grub Screw must be refitted correctly so the door is locked in the closed position – do not cross thread the grub screw
- The stove is installed, commissioned & operated as stated in this manual
- The flue installed is the correct AGA flue system
- A Carbon Moxoxide Detector must be fitted in the room with the Stove
- The installation of this stove is in accordance to the latest version as stated under Building Control – Building Regulations 2002 Part J & Gas Safe requirements

For the warranty to be valid this stove must be registered in England or in Wales for a

BUILDING REGULATIONS COMPLIANCE CERTIFICATE

or the equivalent in Scotland, Northern Ireland, Isle of Man, Guernsey and Jersey

please visit this website for detailed information

<https://www.gassaferegister.co.uk/help-and-advice/gas-safety-certificates-records/building-regulations-certificate/>

Please note - The AGA warranty does not cover the installation of the stove or the flue system if these are found to be at fault they are not covered under the warranty

What are the Building Regulations?

The Building Regulations are designed to make sure buildings are safe to use and inhabit. As part of this aim, in England and Wales local authorities must always be informed when a heat producing appliance is installed in a property, so a Building Regulations Compliance Certificate can be issued.

If your Gas Safe registered business has installed a heat producing appliance (such as a boiler or fire), they'll need to comply with the regulations and notify (self-certify) these appliances with the relevant local authority within 30 days of installation. If you're a homeowner, it's also up to you to ensure the Building Regulations are adhered to by making sure your engineer notifies the installation.

If you need a duplicate Building Regulations Certificate, please visit the Gas Safe website

How to get a Building Regulations Certificate

Your Gas Safe registered engineer just needs to notify through Gas Safe Register. Once they've done this, we will inform your local authority and you'll receive your Building Regulations Compliance Certificate in the post in 10-15 working days.

Because the Building Regulations Compliance Certificate belongs to the property in which the appliance has been installed, make sure you keep it safe; it'll come in useful if you sell your home or decide to re-mortgage. For example, if a new boiler has been installed, the certificate confirms that the boiler has been installed correctly and safety at the property.

Requirements in other regions

Similar requirements to the above exist in [Isle of Man](#) and Guernsey.

The requirements are different if you're in Scotland or Northern Ireland. For more information on Scottish regulations, head to the [Scottish government website](#). For Northern Ireland, visit [Building Control NI](#).

Registered engineers can notify through Gas Safe Register. Once complete, a Building Regulations Compliance Certificate should arrive via post within 10-15 working days. As the certificate belongs to the property, you'll need to keep it in a safe place as it'll be useful should you decide to sell your home (to pass onto the next owner) or re-mortgage.

Similar requirements to the above exist in Isle of Man and Guernsey, but not in Scotland and Northern Ireland. For more information on Scottish regulations you can visit the [Scottish government website](#), and further details on the regulations in Northern Ireland are available on the [Building Control NI site](#).

Additional information

Once your new installation is complete, the local authority needs to be notified within 30 days. You can contact us at Gas Safe Register to:

- Check your engineer has notified the appliance
- Order a replacement certificate if needed

If your Gas Safe registered engineer hasn't notified the installation within 30 days, contact them and ask them to do so as soon as possible.

**For the warranty to be valid this stove must be registered in England or in Wales for a
BUILDING REGULATIONS COMPLIANCE CERTIFICATE**

or the equivalent in Scotland, Northern Ireland, Isle of Man, Guernsey and Jersey - please visit this website for detailed information

<https://www.gassaferegister.co.uk/help-and-advice/gas-safety-certificates-records/building-regulations-certificate/>

Please note - The AGA warranty does not cover the installation of the stove or the flue system if these are found to be at fault they are not covered under the warranty

Installation Information

Please complete the following form for reference when required:

Ref.	Description	Please Complete
1	Which retailer did you purchase the stove from?	Name & Address of Retailer:
2	What date did you purchase your new stove?	Date:
3	What was the name of the gas fitter that installed your stove?	Full Name: Contact Number:
4	What is the installer Gas Safe Registration Number?	Gas Safe Registration No.:
5	What is the serial Number of your stove? <i>This can be found inside the front door above the bottom hinge</i>	Serial Number:
6	What date was your stove installed?	Date:
7.	The AGA Name, Model & Gas Type reference for this stove is	Name - Ellesmere or Ludlow Model – ECGW Wide Body Model Gas Type – LPG Gas

Technical Data Summary:

Reference	Description	Data
1	Maximum Heat Output – High Flame (LPG Gas)	7.0 kW
2	Efficiency %	82%
3	European Energy Label Rating (EEL Eco Labelling)	“A”

Who Can Fit My New AGA Gas Stove:

Before the Gas Engineer can commence working on this stove they must be Gas Safe - qualified and registered for LPG Gas to install, commission and service this stove to the Domestic Gas Safety (CCN1) standard as a minimum and also have the (HTR 1) Category on their Gas Safe Individual Register listing which can be verified at www.gassaferegister.co.uk

HTR 1 - Category = Fire/Space Heater - Competent in the install, exchange, commission, disconnect, service, repair, safety checking and break down of domestic gas fires, wall heaters, convector heaters, stoves and flueless gas fires.

*The installation of this stove is Notifiable Under Building Control –
Building Regulation 2002 Part J*



Content

Section	Content	Page Number
	Installation Information – please complete	3
1.0	General Notes	5
2.0	User instructions	6
2.1	Emergency Gas Isolation	6
2.2	First Time Operation & Paint Curing & Stove Dimensions	7
	<ul style="list-style-type: none"> • Curing the Paint • Health & Safety – Fitting the Rear Chain Kit & Securing the Flue • Stove Dimensions 	7 8 10
2.3	Understanding the Controls to Operate this Gas Stove	11
	<ul style="list-style-type: none"> • Manually Turning On/Off this Stove • Understanding how to use the Remote Control 	11 12
2.4	Care & Maintenance of the Batteries	19
2.5	What Comes with My Stove	20
3	Installation instructions	21
3.1	Gas Connection	21
3.2	Ventilation	21
3.3	Appliance Free standing Installation	21
3.4	Appliance Building into a False Chimney	21
	<ul style="list-style-type: none"> • Distance to Combustibles and Non Combustibles 	22
3.5	Appliance Fireplace Opening Installation	
	<ul style="list-style-type: none"> • Removing the Inner Glass to Access the Fire bed 	23
3.6	Flue Connection	24
	<ul style="list-style-type: none"> • Fitting the Flue Collars • Rear Exit Configuration • Top Exit Configuration • Relief Valve Flap (RVF) • Terminal Locations, Fitting a Flue Restrictor & Flue Systems • AGA Flue Systems – Flue Kits 1 to 4 • AGA Flue Kits 1 & 2 – Top Exit • AGA Flue Kits 3 – Rear Exit - Snorkel • AGA Flue Kits 4 – Renovation Kit for Existing Chimney 	
3.7	Fuel Bed Arrangements – Step By Step Log Layout	34
3.8	Commissioning the Appliance	47
	<ul style="list-style-type: none"> • Pilot Ignition Check • Burner Check • Pressure Check • Removing the Burner Unit • Frequency Asked Questions • Pairing the Gas Valve to the Remote 	
4.0	Servicing	52
4.1	Cleaning the Ceramics	52
4.2	Servicing the Burner	52
	<ul style="list-style-type: none"> • Gas Control Valve Information • Gas Control Valve Assessment • Error Codes Explained • Cleaning & Servicing the Pilot Assembly • Checking the Batteries 	
5.0	Technical Information	63
	<ul style="list-style-type: none"> • Burner Data 	
5.1	Exploded View of the Parts	64
	<ul style="list-style-type: none"> • Parts List 	
5.2	Warranty Details	66
Appendix 1	Appliance Commissioning Checklist & Customer Sign Off	68
Appendix 2	Annual Servicing Records	69
Appendix 3	Energy Efficiency Label	70

1. General Notes - Important Please Read

This AGA Stoves gas appliance is a High Efficiency, Balanced Flue Log Fuel Effect appliance. It provides radiant and convectional heat using the latest burner technology, as well as having a variable heat output.

- Before Installation, check that the local distribution conditions, nature of the gas and pressure, and adjustment of the appliance are compatible.
- This appliance is intended for use on a gas installation with a governed meter.
- This Gas Installation **may only be installed by a registered professional competent person (Gas Safe Registered and Qualified Installer in the UK)**. The installation must adhere to the requirements of the local and national Building regulations and national standards. This installation manual must also be followed.
- Ensure that the Flue Terminal is not in any way obstructed and is clear of vegetation, i.e. trees, shrubs etc. and that no objects are leant against the terminal or guard.
- **Always clean the Window Panels before the fire is ignited. Any finger prints must be removed, as these will be burnt into the glass and will be un-removable.**
- Do not operate this appliance if the glass panel has been broken (or cracked), removed or with firebox access panels open.
- **Only flue approved by AGA Stoves for this appliance may be used.**
- This appliance is a balanced flue product and is room sealed and as such requires no additional ventilation for operation. However an adequate supply of fresh air to maintain temperatures and a comfortable environment is recommended
- This appliance is designed as a heating appliance, and as such will get very hot in operation; all surfaces are considered to be working surfaces and as such should not be touched. The front door window and surrounds are not considered to be fully secure guards against accidental contact. It is recommended that an approved fire screen be used if children, the elderly or persons with limited mobility are to be present in the same area.
- Do not place curtains, laundry, furniture etc. within a safe distance of 1000mm (HOT ZONE) of this appliance when in operation
- Do not attempt to burn rubbish on this appliance.
- Only use the AGA approved and AGA supplied Ceramic Logs and embers
- If this appliance is extinguished (turned off), on purpose or otherwise, no attempt to relight should be made within 3 minutes as the thermocouple inside the stove needs to reset automatically when the firebox heat reduces accordingly
- Each stove burner has been fully tested before being dispatched, the complete Gas Burner Assembly which includes the Pilot Assembly, Gas Control Valve (GCV) and Remote Control Handset have all be thoroughly tested and approved

2. User Instructions – Important Please Read

2.1 Emergency Gas Isolation - Installation of the Gas Isolation Tap with Pressure Test Point

This stove must be fitted with a Gas Isolation Valve to the side or the rear of the stove which can be easily accessed by the user

MANDATORY REQUIREMENT - When installing this stove the Gas Safe Installer must fit a gas isolation valve at the rear or side of the stove with a pressure test point incorporated into the ON / OFF Tap – this will used to test the gas Inlet/Standing Pressure - Please make the customer aware of where this valve is fitted and that they can access it easily

Gas Isolation Valve – We recommend you turn the gas supply OFF to the stove if you are not using it for a long period of time, please use the gas isolating ON/OFF valve that your fitter would have installed when the stove was fitted.

This **Gas Isolation Valve** is not part of the components AGA supply with the stove, your installer will supply this. Please note it must have a gas pressure test point built into the valve

In the event of a gas leak or if gas is smelt, the appliance must be isolated. This is done by turning OFF the gas at the **ON / OFF** Isolation Tap. This Isolation Tap should be fitted to the rear or side of the appliance, with easily access to operate.

Also turn off the Gas Control Valve via the ON/OFF slider switch which is mounted at the front of the stove at the bottom



This stove is fitted with an 8mm diameter compression fitting on the end of the flexible gas inlet pipe.

From this flexible inlet pipe - the gas isolation tap must be fitted. This must be fitted so the customer is able to easily access and isolate the gas supply to the stove if required

If any foreign objects are found in the Gas Control Valve such as brick dust, this is not covered by the AGA Warranty

2.2 First Time of Operation

Before igniting the appliance, ensure that all packaging, safety stickers and any protective wrapping have been removed, and that the glass has been cleaned, including all fingerprints from the glass.

Ensure that the room is adequately ventilated the first time that the appliance is ignited; we would recommend opening windows if possible.

Curing the Paint – First Time Usage

- Run the appliance at a 25% setting for a 1 hour
- Then at a 50% Setting for 1 hour
- Then Finally on Full Power 100% for 1 hour
- This will then allow the paint the opportunity to fully cure. During this period it is possible for some fumes and vapours to be given off.
- We would recommend keeping children and pets out of the area at this time.

Please Note:

When using this stove with the manual controller, the manual controller is located at the front of the stove at the bottom in the middle. When the stove has been running/burning for a short period of time the stove will become HOT - please be careful if using the manual Controller when the stove is hot, we recommend you use the Remote Handset to operate this stove

In the Hot zone at the front of the stove, do not place to dry laundry as if could cause a FIRE, if children, the elderly or persons with limited mobility are in the room unoccupied a Fire Guard must be installed

HEALTH & SAFETY FIRST



The handle is in the locked position. Before you can open the door, you must remove the grub screw – see below.

DO NOT TRY AND FORCE THE HANDLE OPEN

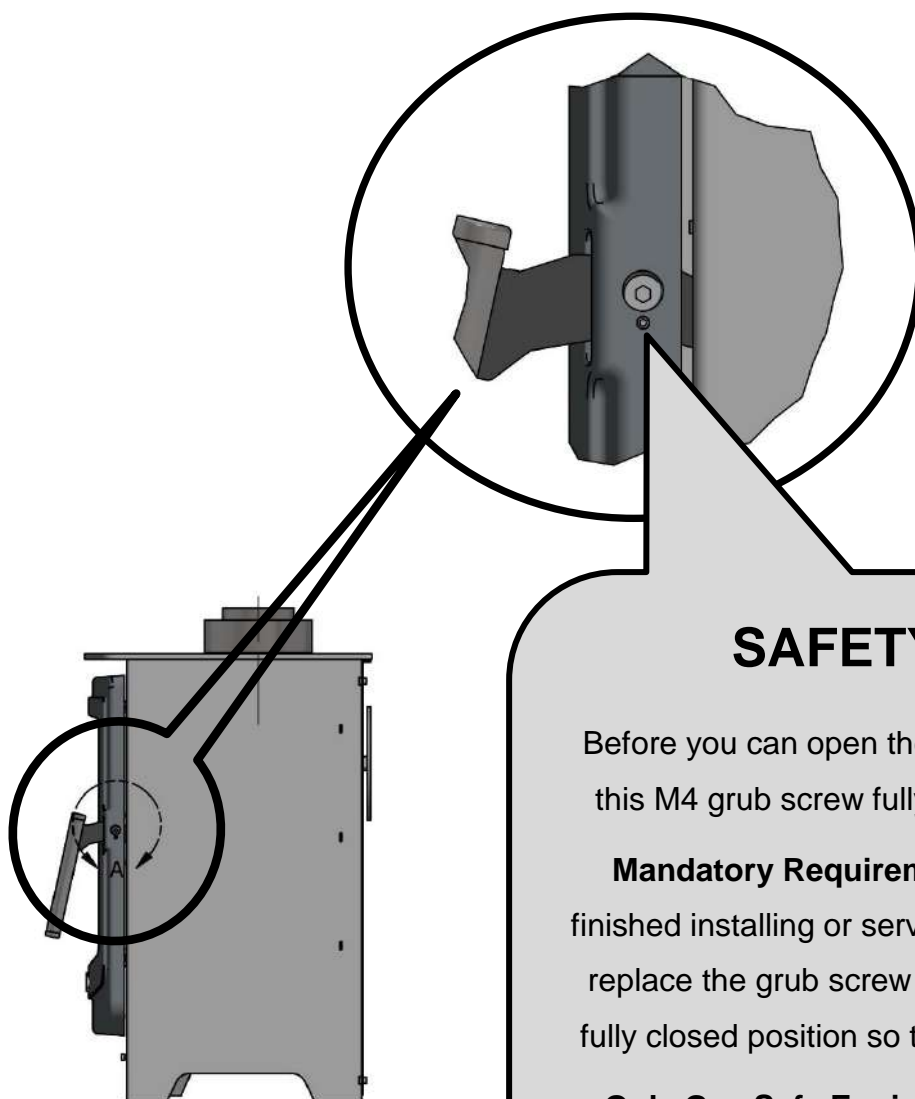

SAFETY FIRST

Before you can open the door you must remove this M4 grub screw fully with an M4 Allen Key.

Mandatory Requirement - When you have finished installing or servicing this stove you must replace the grub screw & lock the handle in the fully closed position so the door is locked closed

Only Gas Safe Engineers can remove this Grub screw

Please ensure the door is locked in the closed position & the Grub Screw has been refitted correctly on completion of the commissioning and/or servicing of this stove

Health & Safety

To prevent the stove from tipping forward when the cast door is open & the flue pipe being pulled off the flue collar

Additional Mandatory Requirements:

Fitting the Rear Chain - During the stove installation process, this stove requires a chain fitting to the rear of the stove as per the following detailed instructions and a “screw in eye” secured into a suitably solid wall directly behind the stove using the enclosed wall fixing for solid brickwork. A different wall fixing would be required for a cavity plasterboard wall which is not supplied as part of this kit

When fitted correctly this will prevent the stove from tipping forward when the door is in the open position

The full installation kit for this is included inside the stove and consists of:

- Chain with Snap Hook fitted to the end of the chain
- Screw in Eye and wall fixing
- Washer (used when screwing the chain onto the back of the stove, with the back panel flange fixing already on the back of the stove holding the back panel in place)

This chain is set up, so it can be used at its maximum length to achieve the 350 mill length required behind the stove when the stove is fitted in front of a combustible wall/material and then you would shorten the chain with the snap hook when fitting in front of a non-combustible wall down to the minimum distance of 100mm from the rear of the stove to the non-combustible wall

Drilling the Flue Pipe for the 2 x Locking Screws - Additionally as a mandate we require the flue pipe once finally fitted (regardless of whether the flue exits from the top of the stove or the rear of the stove to be drilled from either side into the flue collar and a self-tapping screw (size No.8 x 10mm long – pan head stainless steel posi drive) - one each side to be screwed into place so the flue pipe cannot be pulled off the flue collar. See position of screw overleaf on diagram

When drilling the two holes into the Black coloured flue pipe we recommend putting masking tape around the flue pipe where you wish to drill it first, then marking the 2 x hole positions, then using a metal drill bit, drilling through the masking tape this will help to prevent any scratching of the black flue pipe

The flue pipe and flue collar are manufactured from stainless steel when drilling only drill through the outer skin of the flue pipe and the first outer layer (fresh air part of the concentric flue) of the flue collar so the drill is only going in a maximum of 10 mill depth, therefore the inner exhaust flue cannot be damaged. **Please note do not drill into the exhaust pipe of the concentric flue, this is the 100mm inner section of the flue pipe where the exhaust gases are removed**

Then place a small amount of high temperature sealant onto the screws before screwing them in fully to ensure an air tight seal is achieved, then finally fully test the flue for its integrity and the locking bands are all fitted correctly on all joints

If you are fitting the flue to the top of the stove there is a convection cavity below the lid so the 2 x locking screws can be fitted in here, below the lid so they are not seen. But this will involve lifting the lid up to drill and 2 x holes then fit the 2 x self tapping screws then lowering the lid without scratching the flue pipe

When fitting the flue out of the rear of the stove, the 2 x fixing screws at the rear can be fitted on the outside of the back panel plate as they are not seen, but they must be drilled and fixed into the flue collar, but again just the 150mm outer collar of the 2 piece flue collar

Fitting the Rear Support Chain – The Position of the Chain

Drilling the Flue for a Locking Screws

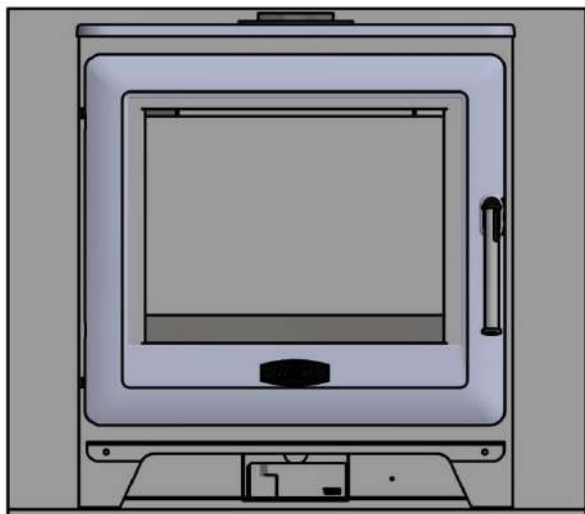

Picture showing the stove from the front

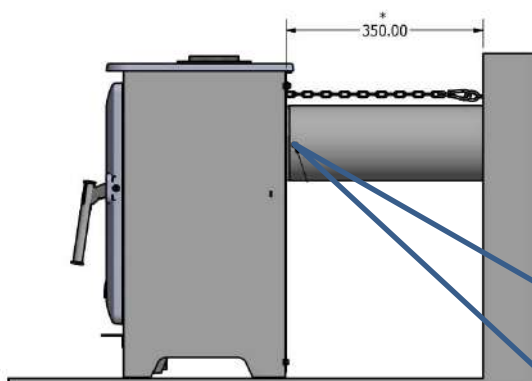

Picture showing the stove from the side with the support chain fitted to a distance of 350mm. This is the minimum distance to a combustible wall

As a mandate we require the flue pipe once finally fitted (regardless of whether the flue exits from the top of the stove or the rear of the stove to be drilled from either side into the flue collar and a self-tapping screw (size No. 8 x 10mm long – pan head stainless steel posi drive) - one each side to be screwed into place so the flue pipe cannot be pulled off the flue collar.

Refer to full instructions on previous page

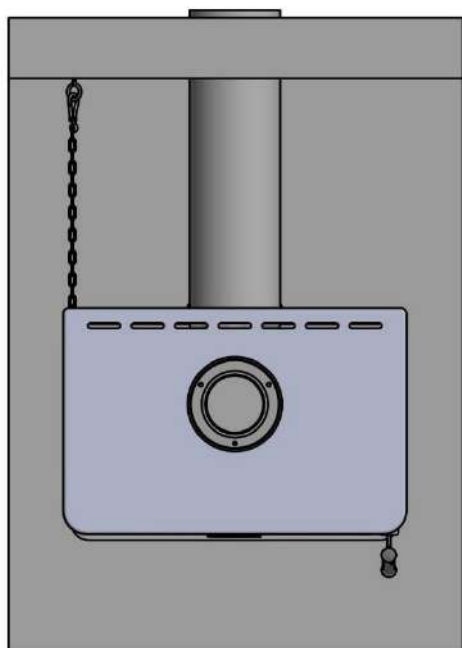

Picture showing the stove from the top view with the support chain fitted to a distance of 350mm. This is the minimum distance to a combustible wall

Mandatory Requirement - Fitting the Rear Chain

The chain can either be fitted to the right hand side or the left hand side of the stove at the rear

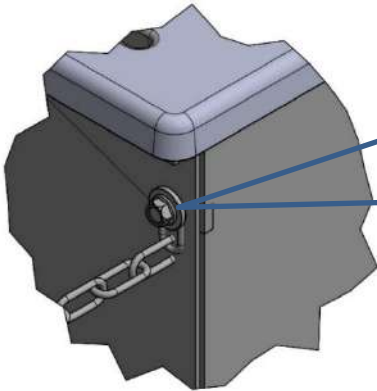

Step 1 - You are required to fit this chain regardless of whether you flue out the top of the stove or out the rear of the stove it is a mandatory requirement to be installed correctly

Unscrew the top bolt that holds on the rear panel and bolt on the chain provided using the washer so the chain is fixed securely to the back of the stove

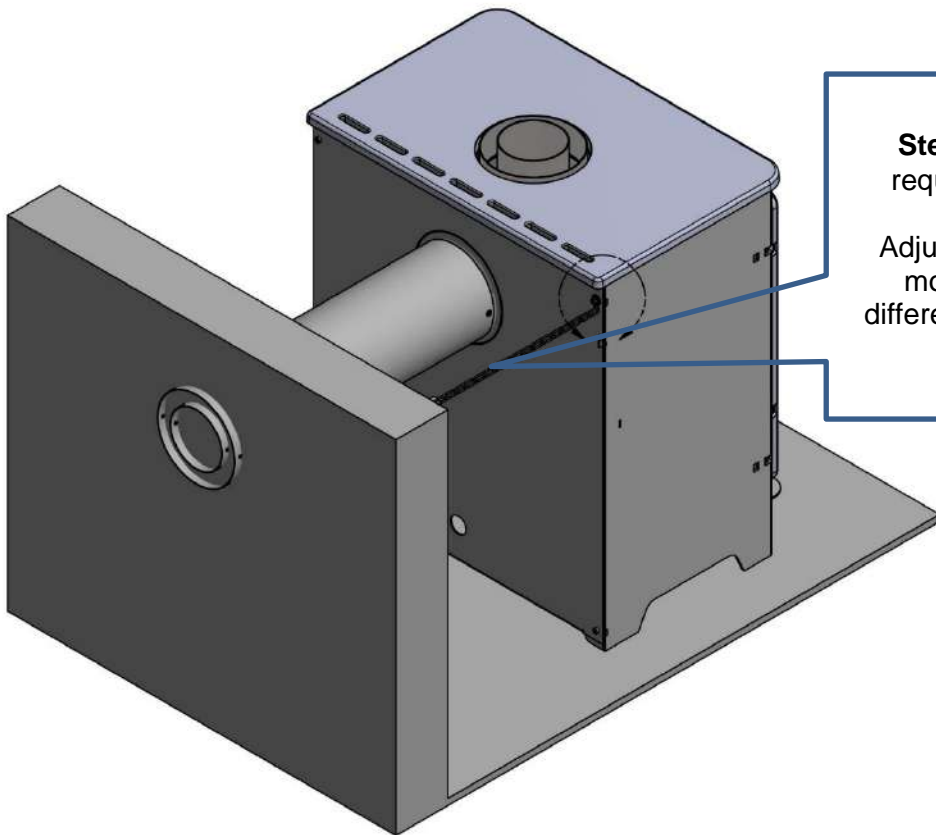

Step 2 - Set the distance you require at the rear of the stove

Adjust the length of the chain by moving the snap hook into a different link to shorten the chain if required

Step 3 - Diagram of eye hook fitted into rear wall - Drill the rear wall directly behind and in a straight line with the bolt holding the chain to the rear of the stove, with a suitably sized masonry drill to the correct depth to match the rawplug provided, then fit the rawplug & screw the eye hook into the wall. If you are fitting the hook into a plasterboard wall you will need a different fixing which is not provided. Ensure the hook is solid and secure in the wall so it will take a weight greater than 150kgs but a maximum of 250kgs

Clip the snap hook onto the eye bolt in the wall insuring the chain is at the right length so it is straight but not over tight but not loose

Now this chain is fitted it will prevent the stove tipping forward when front door is open

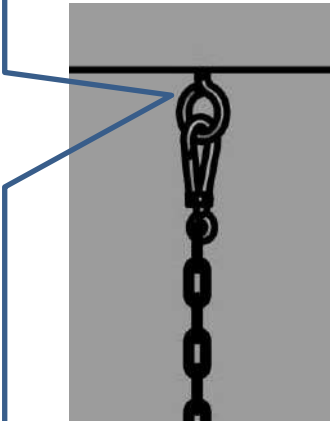

Stove Overview & Dimensions

This stove uses the latest technology gas valve burner technology and air management hence its high efficiency. This stove is fully remote controlled plus it has the added feature of being able to be operated manually from the Gas Control Valve (GCV), which is located in the middle of the stove at the bottom we would only recommend using the manual control if you have mislaid or damaged the remote control handset, (so when the stove is cold can we used for lightening the stove, please note when in the stove is in operation the stove becomes HOT so CARE must be taken not top burn yourself, if you wish to adjust the flame or turn the stove off) this gas stove uses a simple hand held remote control as shown overleaf

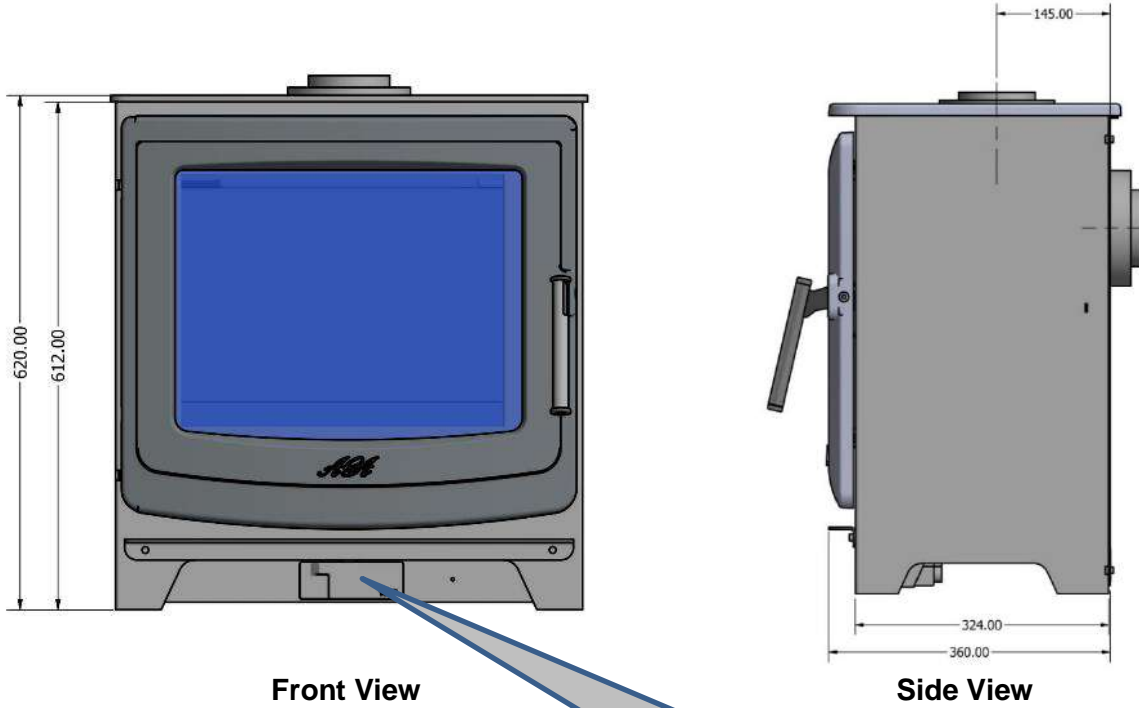

Gas Control Valve (GCV) positioned in the centre for manual operation & battery replacement

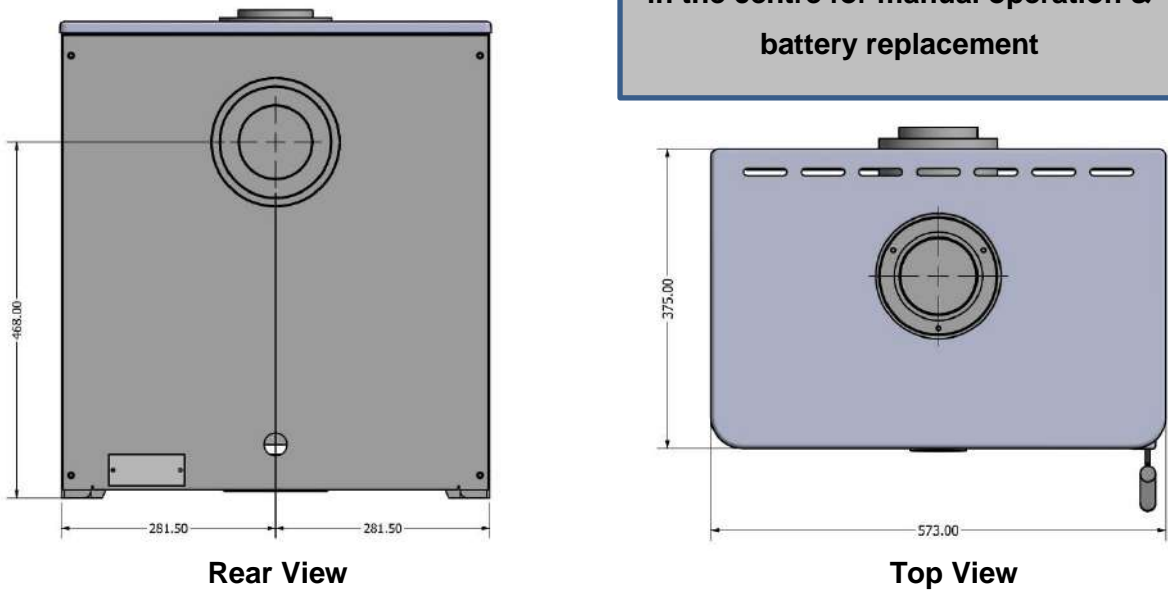

2.3 Understanding the Controls to Operate this Gas Stove

Gas Control Valve (GCV)

This is located under the stove at the front in the middle, a key feature of this stove is it can be operated using the power button to turn it ON/OFF and the - / + to increase or reduce the flame and heat output

The batteries are located in the front of the valve behind the battery cover, so they can be accessed when they need replacing

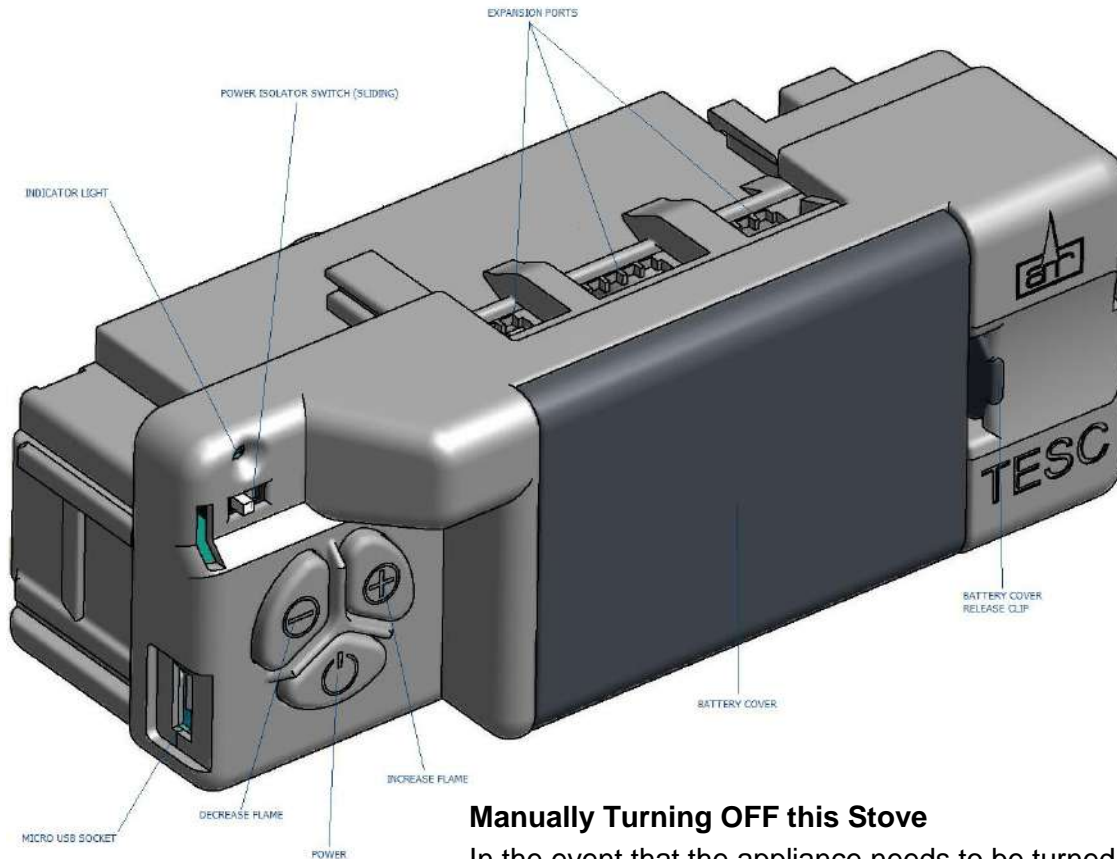

Manually Turning OFF this Stove

In the event that the appliance needs to be turned **OFF** manually, or if the stove is not going to be used for an extended period of time, the Sliding Power Isolation Switch is used to turn the stove off completely.

We also recommend you remove the batteries from the Gas Control Valve and the Remote Handset if the stove is not going to be operated for a period of time, this will then prevent the batteries from leaking

Additionally we recommend you turn off the gas supply to the appliance using the ON/OFF GAS TAP that you installer has fitted to the rear or the side of the stove



Picture of the Handset Remote Controller 2 x AA batteries are supplied, these fit in the rear of the rear of the remote controller – only use the recommend batteries for the Remote and the Gas Control Valve above

USING THE REMOTE CONTROL HANDSET.

IMPORTANT USER INFORMATION – READ THIS BEFORE ATTEMPTING TO OPERATE THE STOVE

NOTE: The handset is paired to the fire during manufacture. DO NOT ALTER THE PAIRING.

For safety reasons, the handset is designed so as to avoid accidental operation. If, during proper use, the handset fails to communicate with the valve there is a possibility that the pairing has been inadvertently altered – in this case the handset will need to be reset and re-paired with the valve.

For Normal Use:- This stove comes with batteries fitted into the remote handset and also in the Gas Control Valve (GCV). However if for any reason they have been removed then prior to using the stove for the first time insert new, Quality alkaline, AA batteries into the valve and handset such as Energizer or Duracell, but DO NOT USE rechargeable batteries. Ensure they are mounted firmly and in the correct orientation, and that the battery covers are replaced fully. Ensure the small isolation switch on the **Gas Control Valve** is switched to the **ON (I)** position.



4 Quick Steps to using the Remote to Turn the Stove ON & Adjust the Flame/Heat settings

Step 1 - Hold the handset as shown, wrapping your hand around the handset to make good contact with both sides. The green unlock light should illuminate, activating the buttons (if the light is not illuminated, the buttons will not work).



Word PILOT Appears



Step 2 - Press and hold the power button, release as soon as PILOT appears on the display in the bottom Left Hand corner (approx. 1-2 seconds). The fire will commence ignition sequence. If successful, the fire will automatically go to maximum heat output (MAX FLAME).

NOTE: Releasing the power button too soon or depressing for too long after the PILOT appear in the bottom LH corner, will cause the fire not to light because system assumes press to be unintentional.



Step 3 - To adjust the flame, hold handset to activate buttons, and use + and - to increase or decrease flame power accordingly. Tapping the button will increase or decrease flame stepwise, holding the button will skip through steps. The fire basket display on the handset will illustrate the level of flame being produced.



MAX Flame & Max Heat



3 Flames – Medium Heat



2 Flames – Low Heat



1 Flame – Very Low Heat



Step 4 - To STOP the fire, hold handset to activate buttons, then press the power ϕ button. The fire should shut off immediately (**N.B STOVE WILL STILL BE HOT** residual heat will remain).

If you wish to start the fire again you must wait for the OFF to be displayed on the handset before trying to re-start as the thermocouple needs to cool down



Understanding the Different Functions of the Remote Control

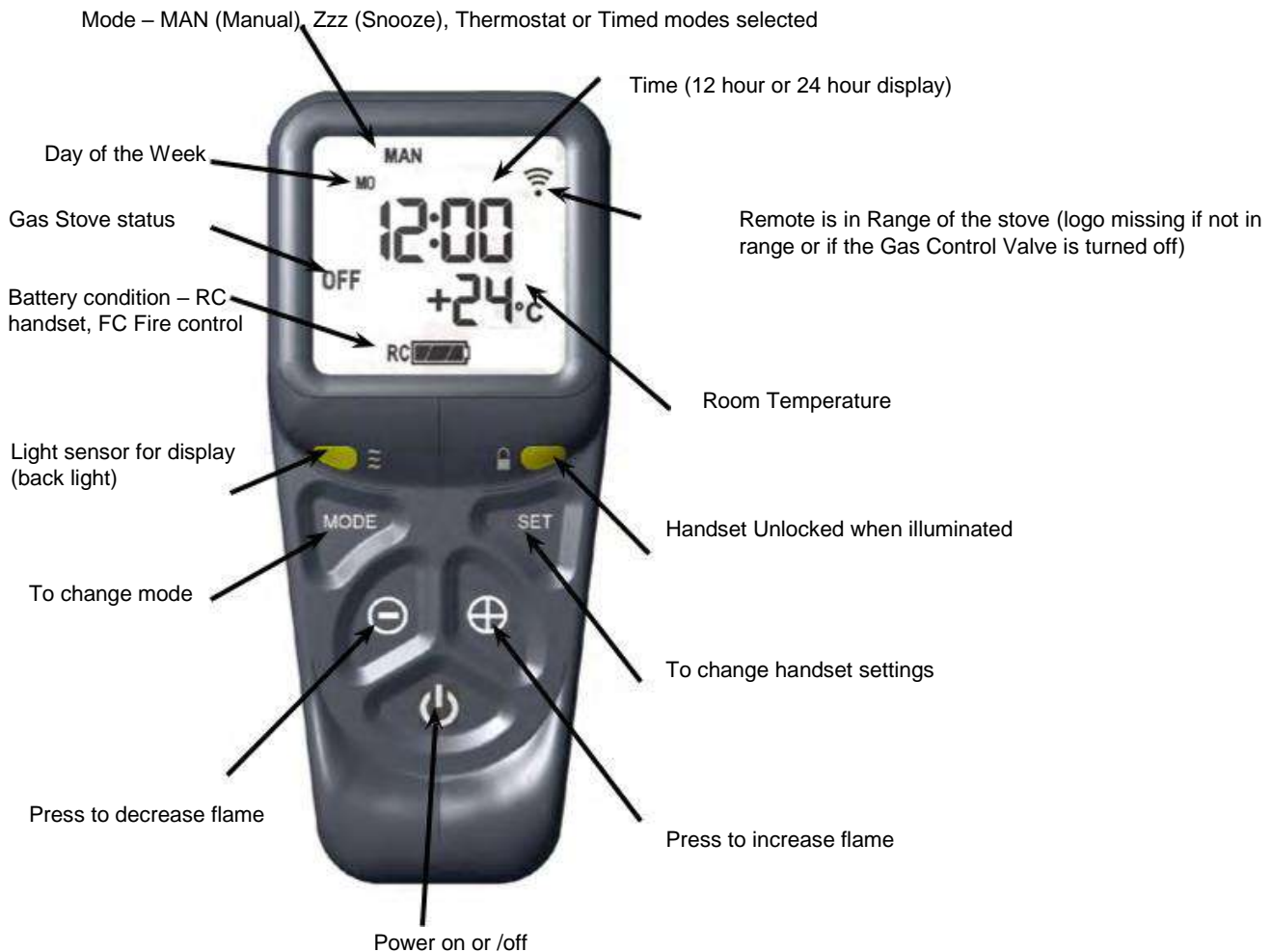

Please Note: The handset is designed to make remote operation of the stove as safe as possible. It has been specifically designed to minimize the risks of accidental operation, with the express intention that successful operation can only be achieved by a conscious, deliberate act.

Using the Remote Control – in more detail

1 - How do I Light the Stove

Important – To operate the handset it must always be unlocked, this is carried out by firmly holding the handset in one hand, which will allow operation of all functions.

Step 1: Unlock the handset by holding it.

The green unlock light will illuminate. Keep the handset held to keep the control unlocked, to enable operation of the buttons.

Step 2: With the other hand press the power button for about 3 seconds until:

A short acoustic beep will be heard and the unlock light on will flash, the word “PILOT” will appear at the bottom left hand corner of the display screen. At this point release the power button.

Step 3: The Fire should be lit within a few seconds, if it fails to light then repeat the process.

2 - Adjusting the Flame Height – *this will increase or decrease the heat output of the stove*

Step 1: Unlock the handset by holding it.

Step 2: Press the “+” button to increase the flame height, press the “-” button to decrease the flame height

3 - Turning the Stove OFF

Step 1: Unlock the handset by holding it.

Step 2: Press and release the power button, this will turn off both the main burner and pilot burner.

4 - Restarting the Stove

If the Stove/fire is extinguished or goes out in use, allow 5 minutes before attempting to restart following the lighting sequence as described in 1

If the fire shuts itself off repeatedly, do not use the fire, and have the flue and fire checked by a suitably qualified person.

If the appliance is not lighting after 4 ignition attempts, close the gas tap and call the installer.

Close the gas tap in case of malfunctions and/or poor operation and warn the installer.

The appliance is designed to display a fault code on the handset in the event of a functional failure, this can be identified from the Fault Finding Section.

Additional Control Functions

In addition, the remote control can also be used to set a number of additional functions:

- Time and Date
- Temperature display in degrees Celsius or Fahrenheit
- Snooze Mode
- Thermostat Function

Caution - Although highly unlikely, there might be very rare occurrences where your appliance's ignition process can be started unintentionally through other remote controls. For example the remote control of your neighbours' gas heater, but also car keys and garage door openers. The result will be that your appliance will burn when you do not want it to.

Unintended ignition of your appliance could be solved or prevented by turning the ON/OFF switch or closing the gas tap near your appliance. This is the safest precaution if the appliance is not in use for long periods to turn the ON/OFF switch to the OFF position and to close the gas tap near your appliance.

5 - Setting the Time

Enter the SETUP menu. Hold the handset to unlock the keypad and keep held throughout the following steps.

Press and hold SET for several seconds. The symbol in the top centre will flash. Press and release the “mode” button several times until the word “SETUP” appears flashing in the top right corner of the display.

Press and release “set” again to enter the “SETUP” menu.

Here you can change the clock from 12 hour or 24 hour format, the day of the week, hour of the day, minute of the day and the display in Celsius or Fahrenheit.

To navigate through the menu “SET” moves to the next parameter and “Mode” move back to the previous parameter. “+” and “-“ change the display parameter.

Setting the display for 12 or 24 Hour display:

The H indicates that it is time to set the timer to either 24 hour display or 12 Hour (AM or PM) display. Press the “+” or “-” button on the handset to toggle between the two settings. When you are ready to confirm the setting you want press the “SET” button to progress to setting the day of the week.

6 - Setting the Day of the Week

Press and release the “+” and “-” buttons until the correct day of the week is shown on the display.

(Mo = Monday, Tu = Tuesday, We = Wednesday, Th = Thursday, Fr = Friday, Sa = Saturday and Su = Sunday).

Press “SET” to accept the day of the week and to progress to setting the Hour of the day.

Note: Whilst doing this setup pressing “SET” advances to the next display and pressing “MODE” will return you to the previous display setting.

7 - Setting the Hour

Press and release the “+” or “-” button to change the hour to the correct hour and press set to store and to move to setting the minute. Repeat this for setting the minutes.

8 - Setting the Temperature Display to Celsius or Fahrenheit.

Press and release the “+” or “-” button to toggle between C and F. When the display shows the desired symbol, press and release the “SET” button to store.

As the important settings above have now been done, press and hold for a few seconds the “SET” button for a few seconds and this will exit the setup menu.

9 - Snooze Mode

Snooze mode is a time period you can set which will turn off the fire after a certain time period has elapsed. This function can be utilised during both the manual and thermostatic modes.

The snooze time period can be set before or during manual operation of the fire. Hold the handset to unlock as described previously and press the mode button as many times as necessary until the word

MAN and the Zzz symbols are flashing at the top of the display. Press and release the set button and this will put the control into Manual snooze mode.

The default time period for the snooze time period is 1:00 hour. Pressing the set button again will show you the snooze time period remaining. This can be adjusted by pressing the “+” or “-” buttons. The timer period that can be set is from 1 minute to 4:00 hours.

After adjusting the time, press set again to enter the time setting required (or if left for a few seconds this time is now stored and used).

Once this countdown timer has reached zero the fire will turn off.

10 - Thermostatic Mode

The handset has within it a thermostat sensor and this can be set so the fire will heat the room to match the temperature set in the handset.

There are 2 temperature types that can be set:

- Day mode temperature that has a SUN symbol on the display
 - the default temperature is 24 degrees Celsius.
- Night temperature that has a HALF MOON symbol on the display
 - the default temperature setting is 18 degrees Celsius.

Hold handset and press and release the mode button several times as necessary until the display has a thermometer symbol flashing at the top of the display. Press the set button to enter this mode.

Press the set button again to see the temperature setting that is set and the mode and on the left of the display is a sun symbol showing it's the day temperature.

If a different set temperature is required, while the display is showing this set temperature press the “+” and “-” buttons to alter the setting. When finished either press set or leave and after a few seconds the new setting will be accepted and the display will return to the time of day screen.

The fire will automatically turn to high or low rate depending on the set temperature. When the set temperature is reached while the fire is in operation, the fire reduces the burner power level each minute until the burner is off. The pilot will remain on for a further 30 minutes and if the set temperature is still too high, the pilot will then also extinguish.

NOTE: If at any time the power button is operated during Thermostat mode, the control will cancel any thermostat operation and return the control to manual mode.

Cleaning and Maintenance

This appliance should be inspected and serviced once a year by a qualified, competent and Gas Safe registered person. The inspection and maintenance must at least ensure that the appliance is working correctly and safely.

It is advisable to clean the appliance of any dust and debris before the heating season and especially if the appliance has not been used for some time. This can be done with a soft brush and a vacuum cleaner or a damp cloth and if required a non-abrasive cleaning agent. Do not use corrosive or abrasive substances to clean the appliance.

Annual Service

For the AGA Warranty to be valid this stove must be serviced once a year by a Gas Safe Qualified Engineer. After an annual service on this stove please complete the record sheet at the rear of the manual

2.4 CARE & MAINTENANCE OF THE BATTERIES

WHAT SHOULD YOU DO?

- Replacing the batteries at least every 12 months will help prevent damage to the valve and handset through leaking batteries.
- Only use new, high quality, alkaline batteries.
- Do not use rechargeable batteries
- Always replace the complete set of batteries and do not mix brands.
- Keep contacts clean and do not bend.
- Remove batteries from the stove Gas Control Valve & Remote handset if the stove is not going to be used for an extended period which is greater than 12 weeks in duration
- Do not operate fire without battery covers fully in place.
- If handset is dropped and damaged, obtain a replacement (see spares section)

HOW DO YOU KNOW WHEN TO REPLACE THE BATTERIES?

- Replace batteries at least every 12 months, during the annual service of the fire.
- The display handset will show a low/empty battery symbol on the screen and produce an audible tone.
- The red indicator light on the Gas Control Valve flashes (approx. every 10 seconds).

WHAT HAPPENS IF I DO NOT REPLACE THE BATTERIES?

- The fire will stop working, or will only work intermittently.
- The handset (or valve) may give error codes, which may or may not be correct.
- The batteries may leak and cause permanent, irreversible damage to the electronics meaning a replacement item must be sought (this is not covered by your AGA warranty).

HOW TO REPLACE THE BATTERIES.

- The control consists of a handset and a Gas Control Valve, within the fire, which both run on batteries.
- The handset requires 2 x AA batteries.
- The valve requires 3 x AA batteries (unless mains powered).
- The battery covers can be opened and removed without tools by pressing the tab down and pulling the cover towards you, example images follow.



**Batteries in the Gas Valve Controller
Mounted at the front of the stove**



**Replacing the Batteries in the
Remote Controller**

2.5 What Comes with My Stove

Packing List - The Following Items are placed within the Firebox for Safe keeping during transit

- A - Inner Exhaust Flue Collar (100mm Diameter) with gasket seal
- B - Outer Fresh Air Flue Collar (150mm Diameter) with gasket seal
- C - Sealed packet of screw to fit the above flue collars consisting of:
 - 4 x *Stainless Steel M5 x 16mm long Cap screws* – for fixing the *Outer Flue Collar*
 - *Spring locking washer* - for fixing the *Outer Flue Collar*
 - *M5 x Flange Nuts* – for fixing the *Inner Flue Collar*
- D - Remote Control with battery fitted & and already paired to the stove – ready to work
- E - The log set and Ember pack is in a cardboard box and placed inside the stove firebox
- F – Rear Chain Fixing Kit (consists of Chain, Snap Hook, Screw Eye, Washer & Rawplug)
- G – Flue Restrictors (1 x 35mm wide & 1 x 45mm wide)
- H – This Installation and Operating Manual



ITEM A



ITEM B



ITEM C



ITEM D



ITEM E



ITEM F



ITEM G

Pictures Not to Scale

You have to purchase the AGA Flue Kit separately please refer to the Flue Kits

3. Installation Instructions.

Before commencing Installation, confirm that the details on the appliance data plate correspond to the local distribution conditions, gas type and pressure to which the appliance is to be installed.

Ensure that gas supply and supply pipe is capable of delivering the required volume and pressure of gas and is in accordance with the rules in force.

3.1 Gas Connection

This appliance has a gas inlet connection of Ø 8mm. **MANDATORY REQUIREMENT - You must fit an isolation tap with a pressure test point incorporated into it at the rear or the side of the stove so the gas supply can be easily isolated if required by the end user**

3.2 Ventilation

This appliance is a Balanced Flue room sealed appliance, and as such needs no additional ventilation. However an adequate supply of fresh air to maintain temperatures and a comfortable environment is recommended.

This appliance may be installed in a completely sealed or mechanically ventilated house.

3.3 Appliance Free-standing Installation

Determine the position required for the appliance.

Create a gas connection with ON/OFF TAP for the appliance in approximately the correct location for the gas controls as defined in this Manual - 3.1 Gas Connection

All the gas controls are connected to the Burner of the appliance. (They are Factory Fitted, do not adjust them in any way as this will void any warranty)

Do not make any adjustments to the appliance, this includes gas pressures for the inlet/standing pressure and outlet burner pressure (Hot & Cold)

This appliance has adjustable M6 threaded pads on the bottom of each foot/corner, (please note the M6 Setscrews/bolts are supplied with the stove as they bolt on the 4 x throw away steel brackets that hold the stove onto the transport pallet) if used these must be set to the desired length before the flue position is finalised. Fine adjustment of the stove is available via these M6 bolts. Do not make any adjustments to the appliance, except the adjustment in the bolts to level the stove if required.

The Flue system should be fitted with a minimum clearance as stated overleaf in the Minimum Clearance Distance to Combustible & NON Combustible Materials table, from any combustible objects or materials; this includes any combustible materials used for the fireplace construction.

As this is a room sealed appliance and the appliance stands appropriately and is securely fixed to the floor, a hearth is not required for this appliance. But a hearth would be a requirement when being fitted to a combustible floor surface such a carpet, wooden or laminate flooring

A minimal gap of 100mm should be left all-round the appliance to **Non-Combustible Materials**.

For minimum clearance to combustible materials see table overleaf – However any installation must be in accordance with the latest Local Building Regulations

3.4. Building the Fireplace into a False Chimney

Construct a studwork fireplace to the desired sizes. Any combustible material used to construct the Fireplace must not be closer than the minimum dimensions quoted in section 3.3 above. Cement Board of minimum thickness 12mm, can be used as a Thermal Break. Please refer to 3.5 for full details

Do not use insulation material (or other) to pack the void around or above the appliance.

Provide ventilation for the fireplace to the minimum amount quoted in 3.3 above.

For minimum clearance to combustible materials see table overleaf – However any installation must be in accordance with the latest Local Building Regulations

Minimum Clearance Distance to Combustible & NON Combustible Materials

Reference Point	Minimum Clearance from Combustible Materials	Minimum Clearance from Non Combustible Materials
Either Side of the Stove	550mm	100mm
Rear of the Stove to the Wall	350mm	100mm
Top of the stove to the underside of the Mantel	As defined by Local Building Regulations	As defined by Local Building Regulations
Hot Zone to the Outside of the Front Door of the Stove	Allow 1000mm to the front as this area gets HOT	Allow 1000mm to the front as this area gets HOT

Diagram for illustration purposes only - Not to Scale

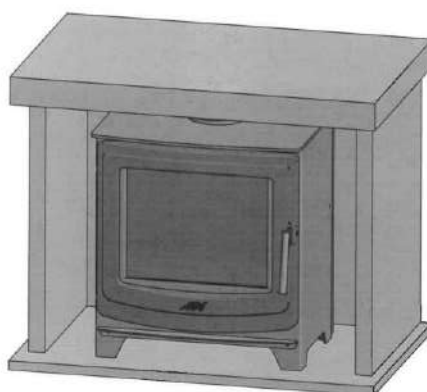

Please Note - In the Hot zone at the front of the stove, do not place to dry laundry as it could cause a FIRE, if children, the elderly or persons with limited mobility are in the room unoccupied a Fire Guard must be installed

3.5 Appliance Fireplace Opening Installation

Determine the position required for the appliance.

Create a gas connection for the appliance in approximately the correct location for the gas controls. With a cut off valve and pressure test point as defined in this Manual - 3.1 Gas Connection

The gas controls are connected to the Burner of the appliance. (Factory Fitted)

This appliance has adjustable M6 threaded pads on the bottom of each foot, (please note the M6 Setscrews/bolts are supplied with the stove as they bolt on the 4 x throw away steel brackets that hold the stove onto the transport pallet) if used these must be set to the desired length before the flue position is finalised. Fine adjustment of the stove is available via these M6 bolts. Do not make any adjustments to the appliance, except the adjustment in the bolts to level the stove if required.

The appliance should be fitted with a minimum clearance as defined in the table above from any combustible objects or materials; this includes any combustible materials used for the fireplace construction.

As this is a room sealed appliance and the appliance stands on it build in legs, a hearth is not required for this appliance. But would be a requirement when being fitted to a combustible floor surface such a carpet, wooden or laminate flooring

If a shelf is to be fitted above the fireplace opening, a gap (as defined by local building Regulations must be adhered to) should be left between the opening and the shelf.

For minimum clearance to combustible materials see table above – However any installation must be in accordance with the latest Local Building Regulations

Removing the Inner Glass and Seal to Access the Firebox

Before you can commence the installation the inner front glass must be removed

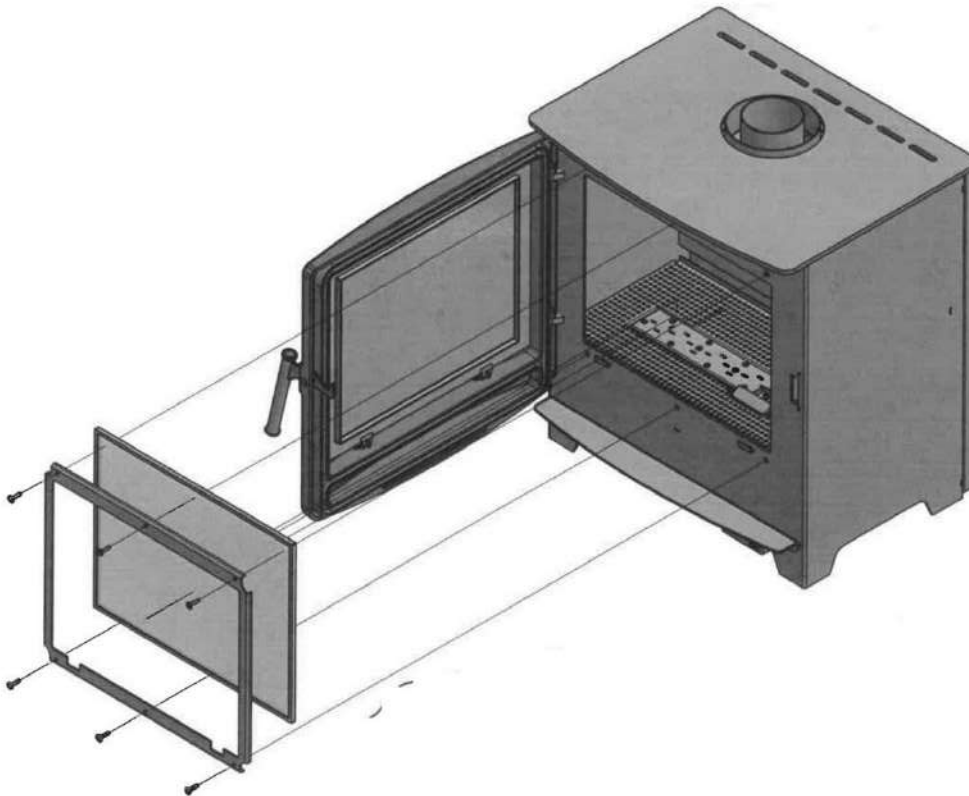

Instructions on how to Remove and Refit the Inner Glass

To access the fire box you need to open the cast door using the handle

Then you will see a steel frame with 6 x M5 flange screws in it, this holds on the piece of ceramic glass which actually forms the seal of the gas firebox. Remove the 6 x M5 flange screws and take off the outer metal frame, the glass then sits in two small lugs at the bottom, lift the glass up gently out of the 2 x holding lugs

Please note the glass has a heatproof fibre gasket fitted all of the way round it on both sides please make sure this is not damaged in anyway

Once the glass has been removed you can then lay the ceramic embers and logs as per the instructions

Re-fit the glass in the reverse sequence but making sure the 6 x M5 flange screws are not over tightened otherwise you will crack the glass when it get hot, they just need to be hand tight to form an airtight seal

Please make sure any fingerprints are wiped off the inside and the outside of the glass otherwise they will mark the glass permanently

When the stove is first lit the glass will form condensation on the inside and that will clear after about two minutes

3.6 Flue Connection

3.6.1 General notes

This appliance may be installed with a roof terminal (C31) or a wall terminal (C11).

This appliance may only be used with 100/150 sized Balanced Flue (otherwise known as Concentric Flue) parts as specified by AGA Stoves. The AGA Stoves specified flue parts have been approved with the appliance. If the appliance is installed on non-AGA Stoves approved parts, AGA Stoves cannot guarantee or accept any responsibility for the proper and safe working of the appliance. This will also void all warranty cover

The flue system must be constructed from the appliance vertically upwards from the top of the stove or horizontally out of the rear of the stove, with all joints being fully locked and sealed using the AGA Stoves specified parts.

This stove can be flued out of the rear of the stove or out of the top of the stove, the 2 x flue collars are supplied loose and the installer needs to fit them as per the following instructions, it is very important that the following instructions are adhered to

PLEASE NOTE - ONLY AGA APPROVED FLUE CAN BE FITTED TO THIS STOVE

The Approved AGA Flue Collars – Manufactured in Stainless Steel – these are supplied loose inside the fire box of the stove



Inner Flue Collar is 100mm outer diameter, it is supplied in the firebox, the seal has been fitted to it already (on some models the seal is white) – please make sure there is no damage to the flue seal. This flue collar allows the exhaust gases to be removed from the stove



The Outer Flue Collar is 150mm outer diameter, it is supplied in the firebox, the seal has been fitted to it already (on some models the seal is white) – please make sure there is no damage to the flue seal. This flue collar allows the fresh air to be delivered into the stove

Fitting the 2 x Flue Collars to the Stove for a Rear Exit Configuration & the Top Blanking Plate –

(Horizontal Flue)

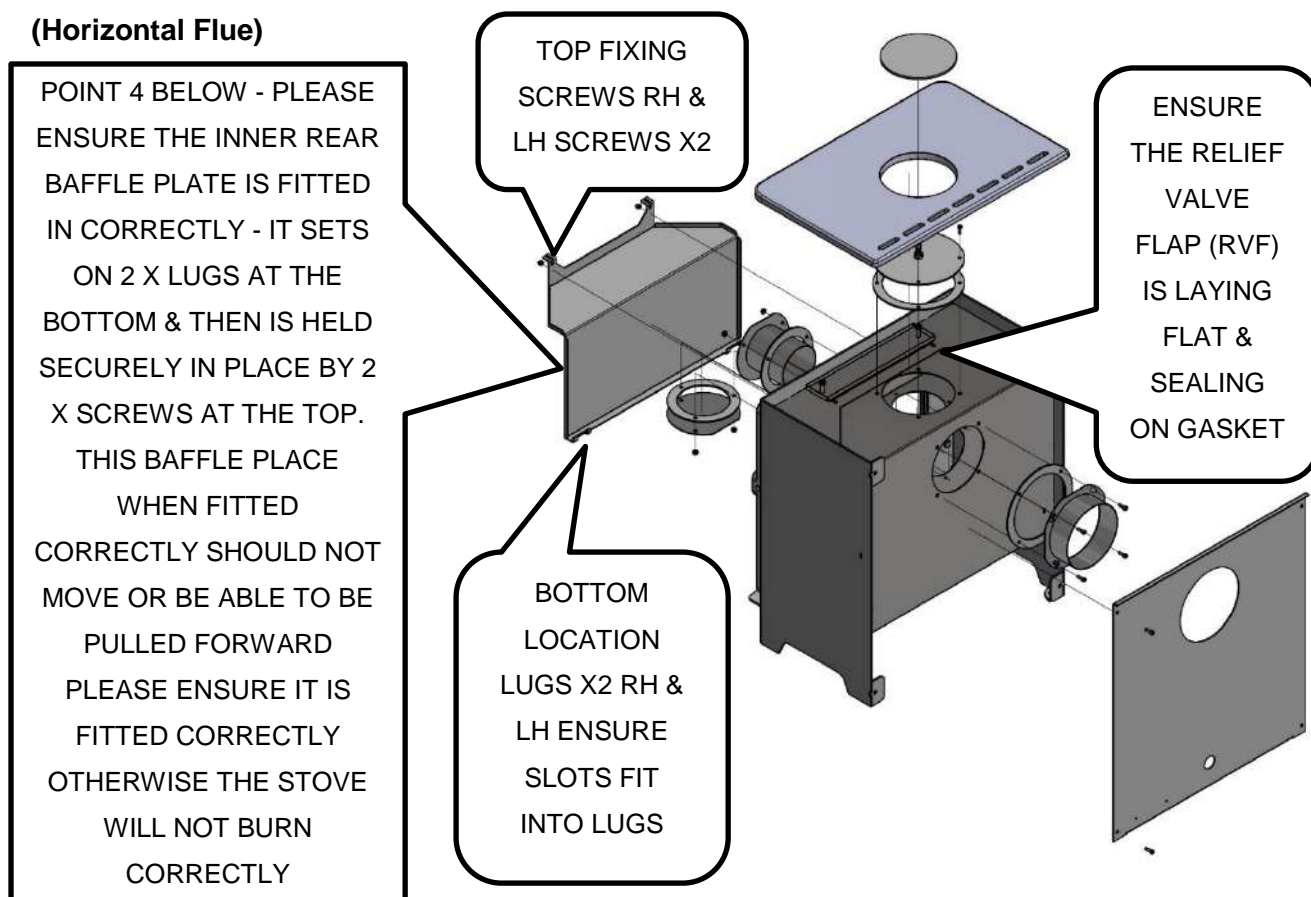

You have already removed the Inner Glass and Seal to Access the Firebox –

As described earlier in this manual

1. Lift off lid and store in a safe place.
2. The top air inlet blanking plate and gasket can now be fitted to the top of the fire (M5 cap screws x 4)
3. Unscrew M5 flange screws (x6) remove front glass and frame and store in a safe place
4. **IMPORTANT** Unscrew M5 flange nuts (x 2) from the inside at the top of the fire and carefully remove the inner heat shield (inner rear baffle plate)
5. The exhaust blanking plate & gasket can be accessed from the inside top of the fire (M5 flange nuts x 3)
6. The exhaust flanged collar & gasket can be accessed from the inside rear of the fire (M5 flange nuts x 3)
7. Unscrew M5 cap screws (x4) and remove back panel and store in a safe place, the panel has a cutaway section for the flue to pass through that will need to be removed
8. The air inlet flanged collar and gasket can be accessed from the rear of the fire (M5 cap screws x4)
9. Replace the lid
10. Screw the top blanking cap plate onto the air inlet blanking plate until it's flush with the lid
11. From the rear of the fire, tighten up the M10 lock nut to the top blanking cap plate to secure
12. Replace the outer back panel and screws
13. Now fit the rear chain fixing kit – as described earlier in this manual
14. **IMPORTANT** Replace the inner heat shield inside the firebox (inner rear baffle plate) AS STATED ABOVE
15. Now fit the rear chain fixing kit – as described earlier in this manual
16. Fit the 2 x locking screws into the flue pipe and flue collar as described earlier in this manual

Exploded View of the Top Blanking Plate – *only required when fitting a rear flue*

The Top Blanking Plate is included in the stove but you only require it if you are going to flue out of the back/rear of the stove

The fitting of this is detailed on the previous page

The blanking plate is on an adjustable screw so you can get it exactly at the right height to match the stove lid and then lock it off from underneath using the locking nut

Please ensure this is fitted correctly as it will prevent the stove lid from moving side to side and back to front

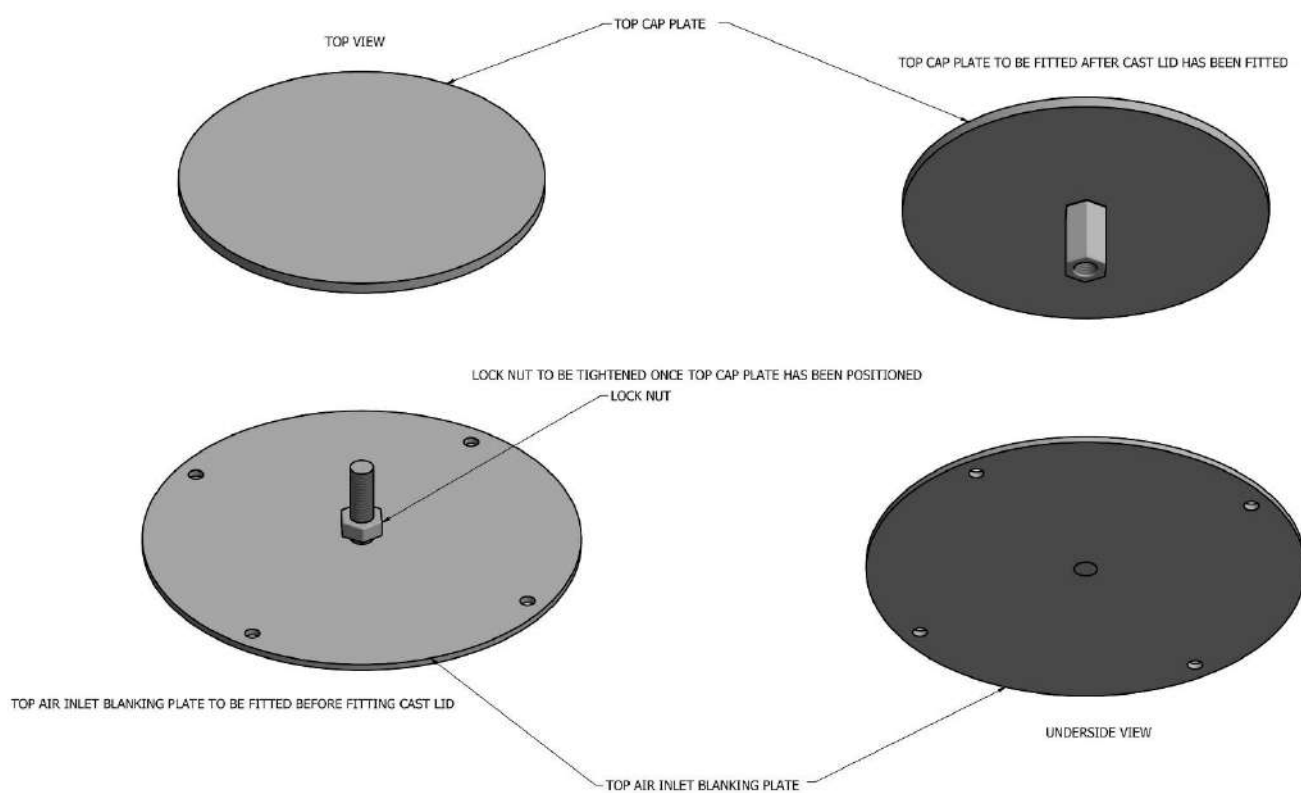

Fitting the 2 x Flue Collars to the Stove for a Top Exit Configuration (Vertical Flue)

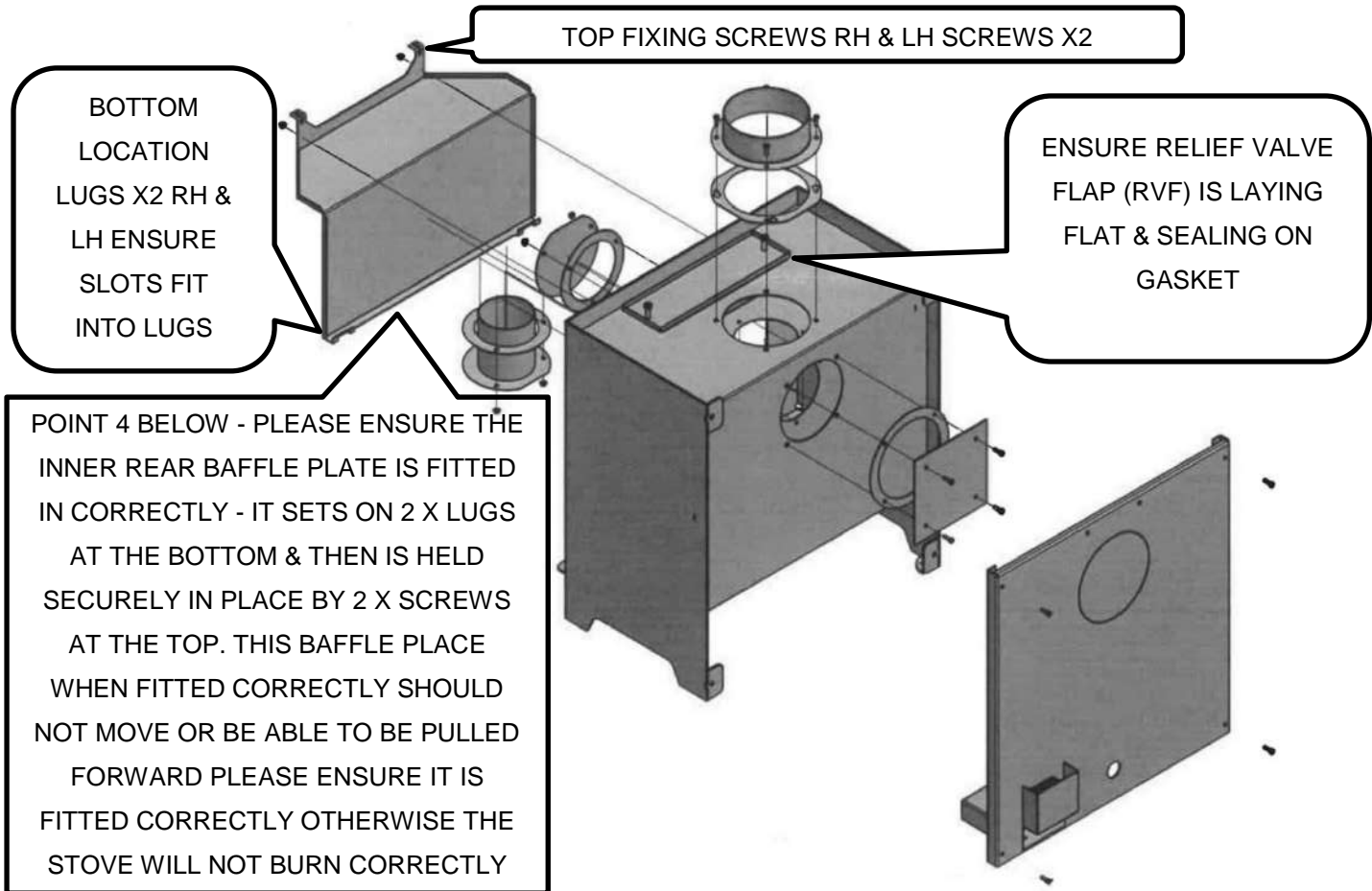

You have already removed the Inner Glass and Seal to Access the Firebox –

As described earlier in this manual

1. Lift off lid and store in a safe place.
2. The air inlet flue collar and gasket (150mm diameter) can now be accessed from the top of the fire (M5 x 16mm cap screws x QTY 4)
3. Unscrew M5 flange screws (QTY x 6) remove front glass and frame and store in a safe place
4. Unscrew M5 flange nuts (QTY x 2) from the inside at the top of the fire and carefully remove the inner heat shield (inner rear baffle plate) replace this inner heat shield once you have completed step 8 – **This must be replaced back into the firebox on completion**
5. The exhaust flue collar & gasket (100mm diameter) can be accessed from the inside top of the fire (M5 flange nuts QTY x 3)
6. The exhaust blanking plate & gasket can be accessed from the inside rear of the fire (M5 flange nuts QTY x 3)
7. Unscrew M5 cap screws (QTY x 4) and remove back panel and store in a safe place
8. The air inlet blanking plate and gasket can be accessed from the rear of the fire (M5 cap screws QTY x4)
9. Refit the parts as per the following steps in reverse for the above make sure the firebox is air tight on all of the seals for the 2 x flue collars and front glass
10. Now fit the rear chain fixing kit – as described earlier in this manual
11. Fit the 2 x locking screws into the flue pipe and flue collar as described earlier in this manual

Please note the stove is supplied with the air inlet and exhaust outlet blanking plates fitted to the rear of the stove. So the 2 x flue collars (supplied loose) would be fitted to the top of the stove for a vertical flue kit to be installed

Pictures of Top Exit Flue Collar Fitted with Top Lid Removed & the Relief Valve Flap (RVF)

Picture showing inner only - 100mm exhaust flue collar fitted for top exit to firebox & Relief Valve Flap



Picture showing both inner & outer flue collars fitted for top exit & RVF



The Relief Valve Flap (RVF) with Ceramic Gasket - fitted underneath to form an airtight seal

As marked with the White Dot

Please Note – The Relief Valve Flap (RVF) is fitted on the top of this stove, please make sure this moves freely up and down on the 2 x dowel pins either side, please check that the ceramic white gasket is intact and the Relief Valve Flap (RVF) is fully down on the top of the stove and making an air tight seal. This Relief Valve Flap (RVF) is held down and in place by its own weight only – **do not place any object on top of the RVF**

3.6.2 Timber Frame Construction

Whilst it is possible to install room-sealed appliances in timber frame properties, great care needs to be taken to ensure that the flue assembly does not interfere with the weather proofing qualities of any outer wall which it may penetrate. Before attempting this work, further details need to be referenced, (e.g. "Gas Installations in Timber Frame Buildings" from the GAS SAFE installer series in the UK).

3.6.3 Carport or Building Extension

Where a flue terminal is sited within a carport or building extension, it should have at least two completely open and unobstructed sides. The distance between the lowest part of the roof and the top of the terminal should be at least 600mm.

Note: A covered passageway should not be treated as a carport. Flues should not be sited in a covered passageway between properties.

3.6.4 Basements, Light wells and Retaining walls

Flue terminals should not be sited within the confines of a basement area, light well or external space formed by a retaining wall, unless steps are taken to ensure the products of combustion can disperse safely at all times. It may be possible to install this Balanced Flue system in such a location provided that it is not sited lower than 1m from the top level of that area to allow combustion products to disperse safely.

Flue terminals should be sited to ensure total clearance of the combustion products in accordance with the included information. When the products of combustion are discharged, they should not cause a nuisance to adjoining or adjacent properties and they should be positioned so that damage cannot occur to other parts of the building. If the outer wall surface is constructed of combustible material, a non-combustible plate should be fitted behind the terminal projecting 25mm beyond the external edges of the terminal.

3.6.5 Terminal Locations.

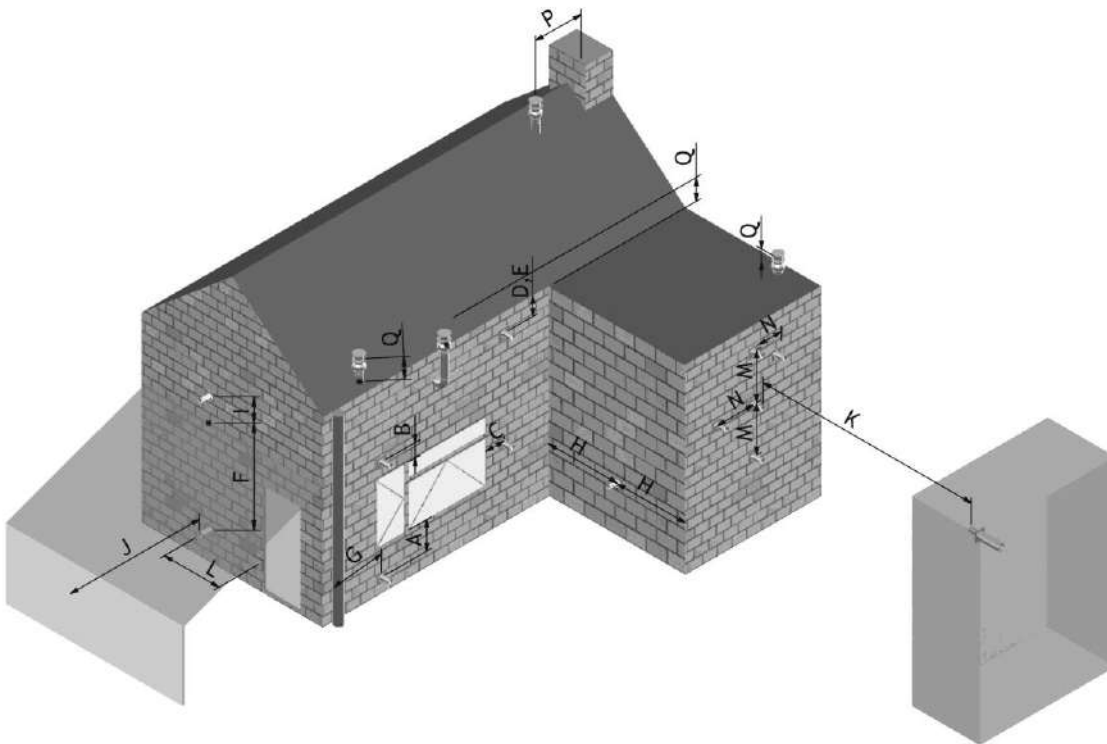

Diagram for illustration purposes only - Not to Scale

Dimension	Terminal Position	Distance (mm)
A*	Directly below an opening, air brick, opening window etc.	600
B	Above an opening, air brick, opening window etc.	300
C	Adjacent to an opening, air brick, opening window etc.	400
D	Below gutters, soil pipes or drain pipes	300
E	Below eaves	300
F	Below balconies of car port roof	600
G	From a vertical drain pipe or soil pipe	300
H	From an internal or external corner	600
I	Above ground roof or balcony level	300
J	From a surface facing the terminal	600
K	From a terminal facing the terminal	600
L	From an opening in the car port (e.g. door, window into the dwelling)	1200
M	Vertically from a terminal on the same wall	1500
N	Horizontally from a terminal on the same wall	300
P	From a vertical structure on the roof	600
Q	Above intersection with roof	150

A* In addition, the terminal should not be nearer than 300mm to an opening in the building fabric formed for the purpose of accommodating a built in element such as a window frame.

Fitting a Flue Restrictor

Depending on the flue configuration you are using to install the gas stove you will be required to fit a flue restrictor in the top exit (100mm diameter) of the stove flue outlet collar

This is a very simple operation as shown below

Within the stove there are two flue restrictors supplied one at 35 mill wide and one at 45 mill wide

When fitting the flue, the required flue restrictor is fitted using one of the screws on the 100 mm diameter exhaust flue collar

Flue Restrictors to be fitted, Ø100/150:

Vertical Rise < 1m - No Restrictor

Vertical Rise 1-2m - 35mm wide Restrictor

Vertical Rise > 2m - 45mm wide Restrictor

Do not fit a flue restrictor if the rear exit is used or a rear exit snorkel kit is being used

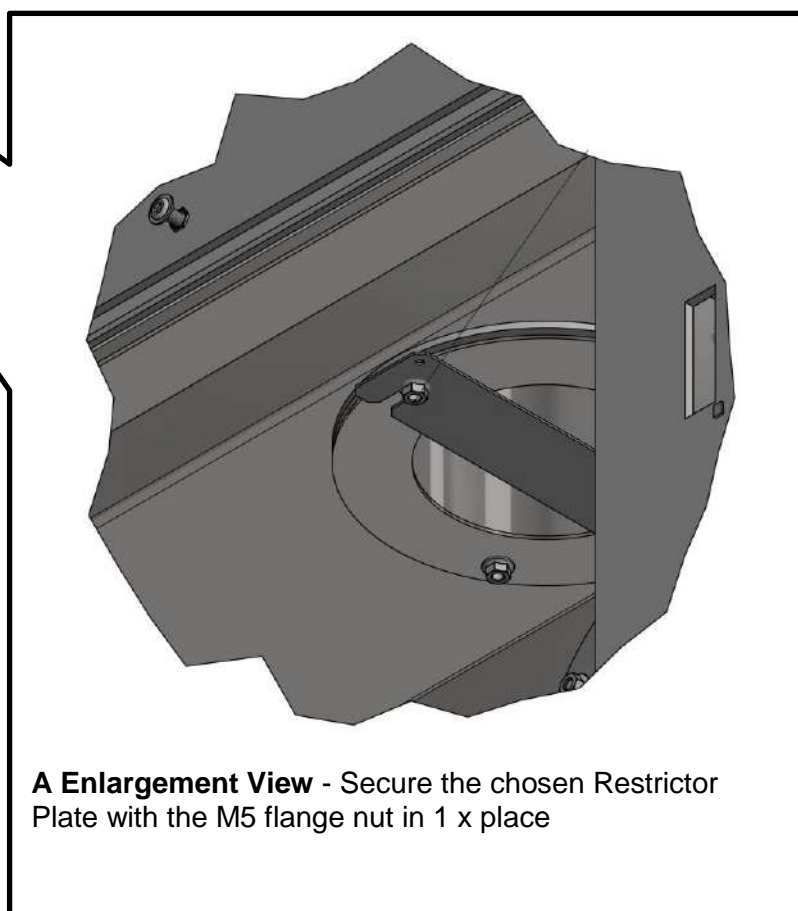
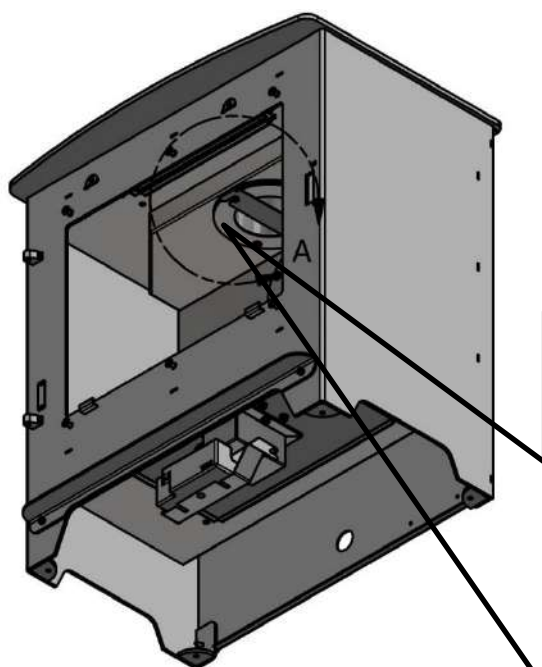

3.6.6 Flue Systems

The Ellesmere & Ludlow range of balanced gas stoves are approved only for use with the AGA approved 100/150 Concentric Flue System

The AGA approved flue is manufactured by Poujoulat under the Duo Gas 100/150 range of Stainless Steel concentric flues and is available in Matt black finish in line with the finish on the stoves or Stainless Steel finish

AGA has put together the following Flue kits in association with Poujoulat

Flue Kit Ref:	Contents: <i>see overleaf for full details</i>	AGA Part Number
Flue Kit 1A – Black Finish	950mm flue pipe, 90° elbow & horizontal terminal	AE4M531085
Flue Kit 1B – S/Steel Finish	950mm flue pipe, 90° elbow & horizontal terminal	AE4M531086
Flue Kit 2 – Black Finish	Snorkel terminal flue pipe adjustable – Rear Exit Only	AE4M531087
Flue Kit 3 – Black Finish	Renovation kit - to fit into an existing Chimney opening	AE4M531088

These kits can either be purchased directly from AGA Spares or directly from Poujoulat. The AGA version has been manufactured in stainless steel & painted black in line with the finish on the stoves

All of the AGA Ellesmere & Ludlow balanced flue gas stoves are fitted with flue collars to fit the Poujoulat 100/150 Duo gas system. Please do not attempt to fit other concentric flue pipes to this flue collar as they will not be a perfect gas tight match. This will void any warranty and would be deemed as an unauthorised installation by AGA and would not meet Building Regulations requirements. Only a registered Gas Safe engineer can install the AGA stove and flue system

The Poujoulat black is the nearest black colour match to the AGA heat proof paint used on the stoves. Please note there can be slight colour and shade variances between the stove and the flue

3.5.6 Horizontal Wall Vent Termination type C₁₁

Flue sizing: Ø100/150 Flue Connector on Appliance is only for Poujoulat Duo Gas

Maximum pipe extension, for outside wall (H) = 1 X Vertical Pipe Rise (V).

Maximum Permissible run (H) see table below.

Vertical Flue Rise (V) metres	Max. Horizontal Flue Run, (H) m for Ø100/150 flue
1	1
1.5	1.5
2	2
2.5	2.5
3	3
3.5	3.5
4	4
4.5	4.5
5	5
5.5	5.5
6.5	6.5
7	7
7.5 and over	7.5

Minimum Vertical Flue Height: 1.0m off the top of the Stove

Maximum Height: 15m

AGA Flue Kit 1A & 1B

Flue Kit – Consists of the following:

- 1 x 950mm Concentric Flue Pipe
- 1 x 90° Swept Elbow
- 1 x Horizontal Flue Terminal is adjustable in length from 360mm to 630mm

AGA Part Numbers:

AE4M 531085 - Matt Black Finish (RAL 9030)

AE4M 531086 - Stainless Steel Finish

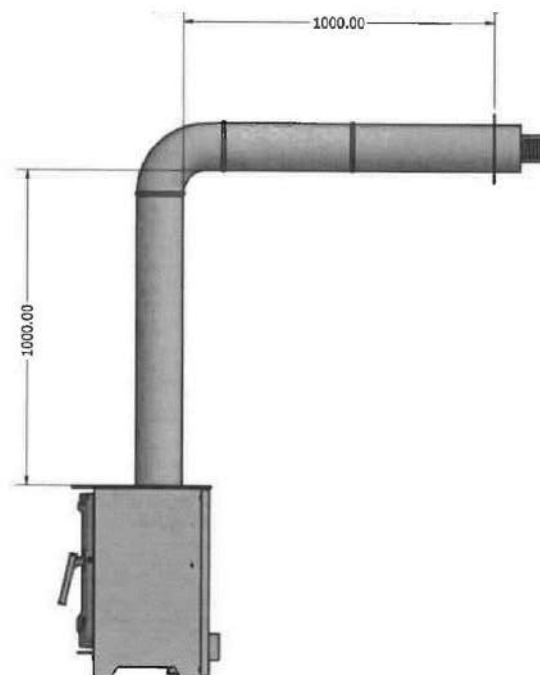

Please Note – The Maximum length of the Horizontal Terminal is 1000mm as per the drawing above, this is when an additional 450mm pipe is added which is not part of Kit 1A or 1B this would be an optional extra

Flue Kit 1A & 1B can only be used when fitting the stove to an outside wall –these kits do not include external wall baskets however they must be fitted to protect the end of the flue terminal

All Diagrams for illustration purposes only - Not to Scale

To Order Flue kits please email Spares@agastoves.org.uk or ring Poujoulat on 01483 461700

AGA Flue Kit 2 – Rear Exit

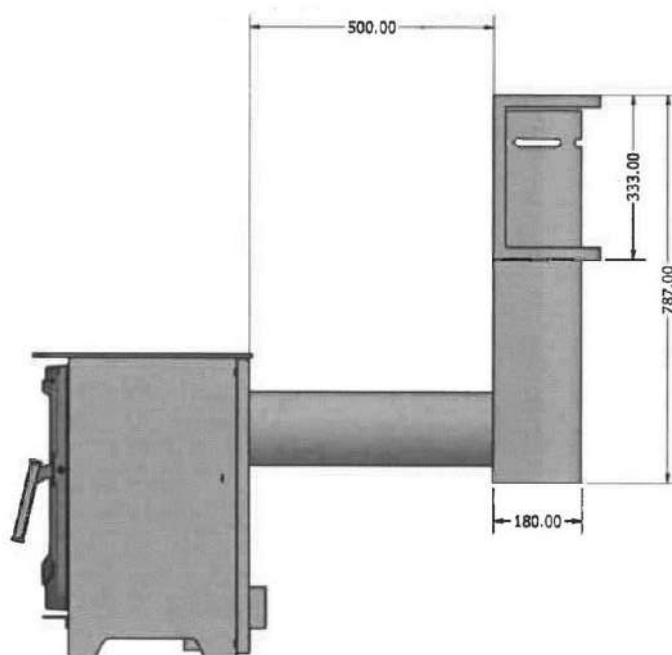

Please Note – The Maximum length of the Horizontal flue is 500mm as per the drawing above

Diagram for illustration purposes only - Not to Scale

Flue Kit 2 – Consists of the following:

- 1 x Snorkel Terminal Flue Pipe – Horizontal flue is adjustable in length from 350mm to 550mm

Use only for rear exit installation on an outside wall

AGA Part Number:

AE4M 531087 - Matt Black Finish (RAL 9030)

Only available in Matt Black

This rear kit is called a Snorkel, this can only be used when the stove is being fitted to an outside wall, the horizontal pipe can be no longer than 500mm long (this pipe is telescopically adjustable)

For this you need to fit the 2 x flue collars onto the rear of the stove, and move the 2 x blanking plates to the top of the stove, you will also need to order from spares a blanking plate for the top plate lid of the stove

To Order Flue kits please email Spares@agastoves.org.uk or ring Poujoulat on 01483 461700

3.6.7 Vertical Roof Vent Termination C₃₁

Flue sizing: Ø100/150 Flue Connector on Appliance is for Poujoulat Duo Gas only

Minimum Vertical Flue Height: 1.0m

Maximum Vertical Flue Height: 15.0m

Flue calculations when using elbows (0-90° permissible), total flue length maximum = 15m and each bend will equate to ½m, Vertical rise (V) must be at least twice the Horizontal run (R), i.e. $V=2H$ (or $H/V \leq \frac{1}{2}$). **Please note a Flue Restrictor must be fitted if the flue is over 1.0m high**

Flue Kit 3 – Renovation Kit to Fit into an Existing Chimney Configuration

Flue Kit 3 – Consists of the following:

- 1 x Insert Vertical Terminal (Rain Cap)
- 1 x Pot Hanger for Insert Vertical Terminal to fit onto
- 1 x Register Plate & Adjustable Concentric Flue Pipe, which is adjustable in length from 390mm to 640mm

AGA Part Numbers:

AE4M531088 - Matt Black Finish (RAL 9030)

Pot Hanger comes painted orange to match the clay chimney pot on your roof

PLEASE NOTE –

THIS KIT DOES NOT INCLUDE THE 100MM DIAMETER STAINLESS STEEL (GRADE 316 OR HIGHER) FLEXIBLE LINER. YOU CAN PURCHASE THIS SEPARATELY TO THE REQUIRED LENGTH OF YOUR CHIMNEY

If the 100mm flexible liner is not supplied from AGA/Poujoulat please make sure the one you install forms an air tight seal on the Register Plate

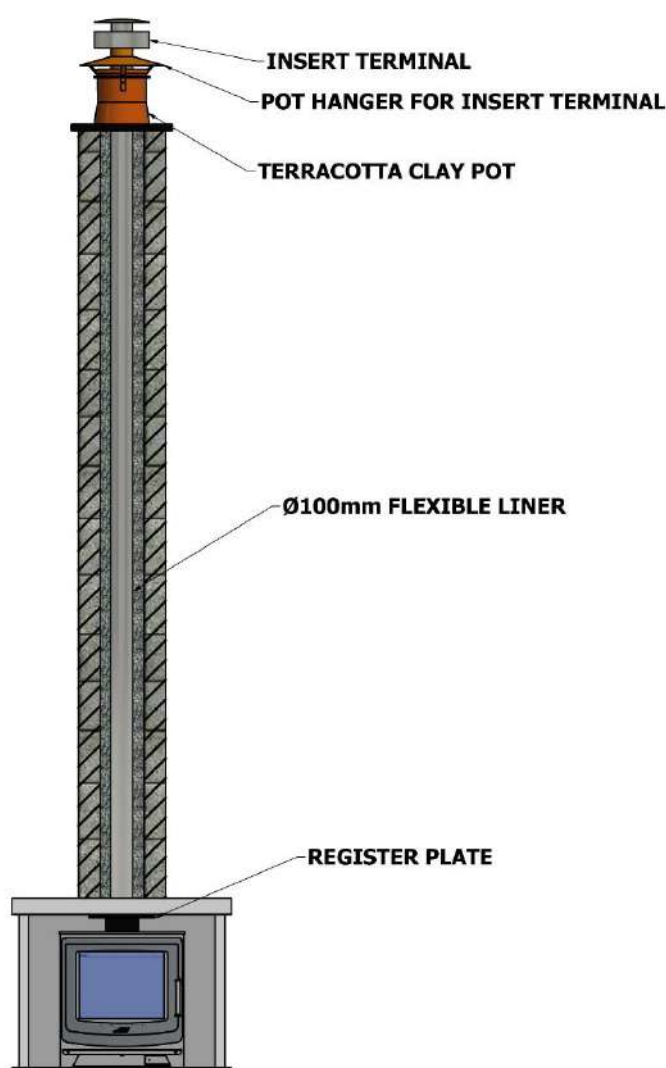

This kit will allow you to install your Ellesmere & Ludlow Balanced gas flue stove into an existing fireplace and use your existing chimney – please note your chimney must be in a good condition for this system to be fitted and fully swept and cleaned before installation, the minimum internal dimension of your chimney must be at least 150mm diameter from the top to the bottom

Diagram for illustration purposes only - Not to Scale

To Order Flue kits please email Spares@agastoves.org.uk or ring Poujoulat on 01483 461700

3.7 Fuel Bed Arrangements.

When arranging the Ceramic Media into the Firebed, it is important that the Pilot area is kept clear and that no Media enters the Pilot shield. The Pilot area includes the pilot shield and the top of the burner to the first slot inside the fence of the pilot shield.

When commissioning or servicing the Appliance Cross Lighting must be checked to ensure smooth lighting of the main burner from the Pilot Flame

Please make sure the correct logs are laid in the correct order as per the instructions

Only use AGA Logs on this Stove

There are 11 Logs in this Kit



Ceramic Main Rear - Log 1 – QTY x 1



Ceramic Log 2 – QTY x 1

Ceramic Log 3 – QTY x 3



Bag of Ceramic Shale – to be laid on the Burner Grate



Ceramic Log 4 – QTY x 1



Ceramic Log 5 – QTY x 1



Ceramic Fir Cone Log 6 – QTY x 2



Ceramic Log 7 – QTY x 2

Please note – If the logs are not laid as per the instructions the overall efficiency performance and flame pattern of this stove will be greatly affected. If additional or Non approved AGA Logs are added to this stove it will void your warranty

3.7.1 ECGW Ellesmere & Ludlow Gas Stove – Log Layouts – 11 Logs to Lay

STEP 1



STEP 1 - Scatter the bag of Embers over the top of the burners as shown, keeping the pilot area clear and the Pilot Assembly shroud as marked in the white circle

Pilot and Cross Over Light area must be left clear of embers and logs otherwise this will prevent the stove from lightening correctly

STEP 2



STEP 2 - Position Main Rear Ceramic Log 1 at the rear of the silver burner tray as per the picture – As marked with the White Dot

Pictures not to scale



STEP 3



STEP 3 - Position Ceramic Log 2 below so it sits on top of Main Rear Log 1 as per the picture – As marked with the White Dot

Pictures not to scale



STEP 4



STEP 4 - Position Ceramic Log 4 so it sits on top of Log 1 to the Right Hand side – as per the picture above – As marked with the White Dot



Pictures not to scale

STEP 5

Step 5 – Position Ceramic Fir Cone Log 6 so it sits at the bottom of Log 4 but at the front but clear of the Pilot Assembly Zone – as per the picture above – As marked with the White Dot

Pictures not to scale



STEP 6



Step 6 – Position Ceramic Fir Cone (2nd Fir Cone) Log 6 so it sits at the end of Log 4 – as per the picture above – As marked with the White Dot

Pictures not to scale

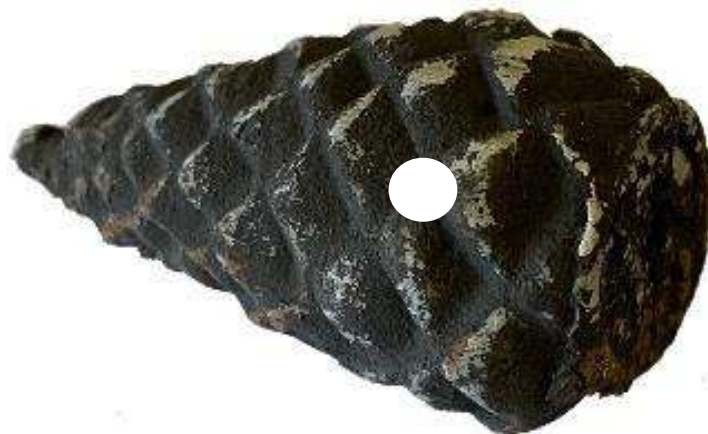

STEP 7

Step 7 - Position Ceramic (1st one) Log 3 so it sits at the end of Log 1 on the left hand side of the firebox – as per the picture above – As marked with the White Dot

Pictures not to scale



STEP 8



Step 8 - Position Ceramic (2nd one) Log 3 so it sits over the top of the Pilot Assembly, but not touching it and at the back rest on Log 1 – as per the picture above – As marked with the White Dot

Pictures not to scale



STEP 9

Step 8 - Position Ceramic (3rd one) Log 3 so it sits at the rear of the firebox on the Right Hand side, at the end of Log 1, but over Log 4 – as per the picture above – As marked with the White Dot



Pictures not to scale

STEP 10



Step 10 - Position Ceramic Log 5 so it sits at the front – as per the picture above –
As marked with the White Dot



Pictures not to scale

STEP 11



Step 11 - Position Ceramic Log 7 (1st one) so it sits at the front – as per the picture above –
As marked with the White Dot



Pictures not to scale

STEP 12



Step 12 - Position Ceramic Log 7 (2nd one) so it sits on top of Log 5 at the front – as per the picture above – As marked with the White Dot



Picture not to scales

3.8 Commissioning the Appliance

3.8.1 Pilot Ignition Check

1. Ignite the pilot light as described in the User Instructions
2. Check that the pilot flame stays alight
3. Extinguish the pilot light

Picture showing the Pilot Assembly Complete



3.8.2 Main Burner Check

1. Ignite the pilot light as described in the User Instructions
2. Turn on the main burner as described in the User Instructions
3. Check that the pilot smoothly cross-lights to the burner and that the main burner & pilot stay alight
4. Extinguish the appliance fully

3.8.3 Pressure Check

The appliance is pre-set to give the correct heat inputs as listed in the technical details. No further adjustment is necessary. Always check the inlet pressure and burner pressure on hot and cold

DO NOT ATTEMPT TO ADJUST THE PRESSURES ON THE VALVE THIS WILL VOID YOUR WARRANTY

1. Turn off the gas valve on the appliance
2. Release the screw on the Inlet Pressure test point (this Test Point is part of the ON/OFF Isolation Tap the installer fits and connect a manometer)
3. Check that the measured pressure is as the prescribed supply pressure
4. Perform the test when the appliance is burning on full (High Flame) and with only the pilot alight
5. If the pressure is low, check the gas supply pipes are to a correct sizing
6. If the pressure is too high (more than 5 mbar over) the appliance may be installed, but the gas supply company should be contacted
7. Release the screw on the Burner Pressure test point (see photo below) and connect a manometer
8. Check that the measured pressure is as detailed in the Technical details
9. The measured value should be within +/- 5% of the described value. If this is not the case, please contact the supplier.

When opening these test points the room must be well ventilated and no naked flames or sparks are to be near the stove. You must fully leak test the valve after commissioning



Photo showing the underneath of the burner unit

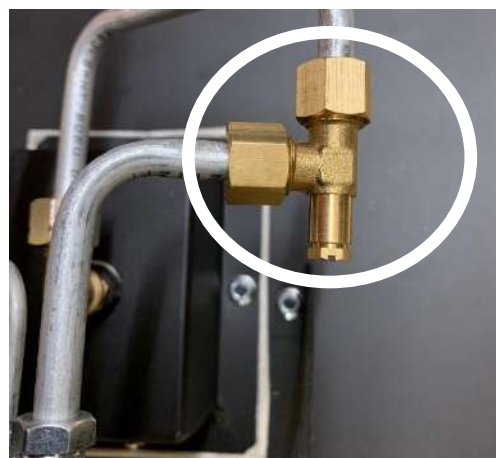
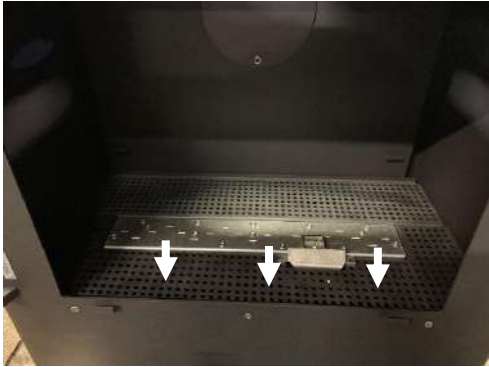
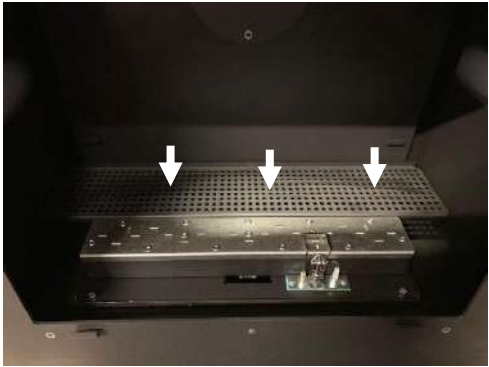
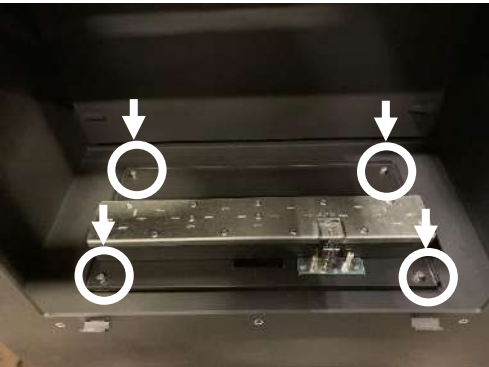



Photo showing the Burner Pressure Test Point

Removing the Burner Unit Out of the Stove

	<p>This is a simple process of removing the burner assembly from the stove body completely</p> <p>This allows you to have full access to the Gas Control Valve and Pilot Assembly and the cables</p> <p>Step 1 - Remove the front lift out grate, gently lifting the pilot assembly shroud the front half of the grate will just lift out – shown by the 3 front arrows</p>
	<p>Step 2 – Remove the back half of the grate by just lifting it out. Once the front grate is out you can put your hand in and lift out the rear half of the grate – shown by the 3 rear arrows</p>
	<p>Step 3 - Now the two grate surround have been removed you can see the burner assembly</p> <p>To remove the burner assembly completely just unscrew and remove the 4 x M5 capscrews</p> <p>As shown by the 4 Arrows</p>
	<p>Step 4 - the burner assembly complete will now just lift out of the stove to give you full access to all of the components. There is a high temperature gasket around the underneath of the burner assembly top plate, please make sure this stays intact as this is what is used to form an airtight seal if damaged replace with a new one</p> <p>To re-assemble the burner assembly back into the stove just follow these four steps in reverse</p>

FREQUENTLY ASKED QUESTIONS

NOTE: ONLY ATTEMPT WORK AS RECOMMENDED IN THESE INSTRUCTIONS AND WHERE YOU ARE SUITABLY QUALIFIED

WHAT SHOULD I DO IF MY FIRE DOES NOT LIGHT OR STAY LIT.

- Check if gas supply is on.
- If the fire is hot, wait for fire to cool down.
- If your fire has a remote handset, put the handset to one side and access the gas valve in the fire (check user instructions for details on how to do this).
- Remove battery cover from Gas Control Valve and check batteries are ok, with no leaks visible, or any other contamination present. If in doubt replace with new, unused batteries.
- When replacing batteries, ensure contacts are clean, dry, and free from any contaminants or surface damage. Be careful not to bend or displace contacts.
- Ensure to mount batteries in correct orientation.
- Replace battery cover on valve.
- Check ceramic logs are in correct place and in good condition.
- Perform any general cleaning of the fire as detailed in this manual, particularly around the pilot assembly.
- Replace correctly any part of the fire that was removed to allow access to the valve.
- If the red light on the valve is lit, reset by pressing on/off button briefly (light should go out).
- Start fire using control buttons on valve.
- If fire does not light normally, wait until red light on valve indicates error or lockout. **NOTE:** the valve may make several attempts to start the fire, this may take some minutes. **DO NOT** interrupt the valve while it completes this process.

If the fire still does not function correctly:-

- Double check all of the above, in particular that the batteries are good, mounted correctly, and all contacts are clean and sturdy.
- Ensure the Pilot Assembly is clean or replace with a new Pilot Assembly unit.
- Reset the valve as above.
- Attempt to restart the valve several times.

If the fire lights, and appears to work correctly, pick up the handset to check correct function:-

- Hold the handset firmly, the unlock keypad light should be lit, solid green.

If **NO LIGHT** present on handset:-

- Check the batteries in the handset are good, mounted correctly and firmly, and there is no contamination or surface damage to the contacts.
- Clean and replace batteries as necessary.
- **NOTE:** If the battery contacts are contaminated (e.g. previous battery leakage) the handset may be permanently and irreversibly damaged, meaning a new handset may need to be purchased.

IMPORTANT NOTE: THE HANDSET IS PAIRED WITH THE VALVE IN THE FIRE DURING MANUFACTURE. PAIRING IS NOT LOST IF BATTERIES ARE REMOVED. THE DISPLAY ON THE HANDSET MAY LOSE RECORD OF THE TIME IF BATTERIES ARE REMOVED BUT PAIRING WITH THE VALVE WILL REMAIN. REFER TO INSTRUCTIONS RELATING TO SETTING THE TIME TO RESTORE TIME TO THE DISPLAY.

If the green indicator light is flashing like a heartbeat, the handset is not communicating with the valve (on the display handset the communication symbol  will be missing)

Communication can be lost for various reasons including, but not limited to:-

- The slide switch on the valve not in **ON** (I) position.
- The batteries in the valve being low on power, or out of power.
- The handset being too far from the fire.

If the above are all in order and the handset is still flashing, pairing with the valve may have been unintentionally altered. The handset will need to be reset, and a new pairing with the valve established (see section on restoring handset communication).

RESTORING COMMUNICATION WITH THE REMOTE HANDSET.

If the handset has lost communication with the control valve, when activated the handset will display a constant green light which pulses brighter periodically, and the  symbol will be missing from the display.

The handset will need to be reset to allow it to accept a new pairing, in order to do this follow the steps below:-

1. Ensure good batteries are firmly and correctly mounted in the handset.
2. Hold the handset firmly to unlock the keypad (keep hold of the handset during the remaining steps).
3. Press and hold the **SET** button (approx. 3 seconds) until you hear a second beep.
4. Release **SET** button. PROG and SETUP should now be visible at the top of the display.
5. With SETUP flashing, press and release **SET** to enter the menu.
6. Keep pressing **SET** until CA 0 is displayed on screen.
7. Press **+** or **-** to change CA 0 to CA 1, then press **SET**.
8. The display should now read **7ESC rX** (where **X** is a number).

The handset has now been reset to factory settings and is ready to receive a new pairing instruction

PAIRING THE GAS CONTROL VALVE (GCV) WITH THE REMOTE CONTROL HANDSET.

Ensure the handset and fire control valve have good batteries.

If the handset is in factory reset condition the display will read **7ESC rX** (where **X** is a number).

Picking the handset up, and holding firmly, will unlock the handset and the green unlock light will illuminate. If the ambient light level is low, the display backlight may also illuminate.

Follow the steps below:-

1. Ensure the power isolation slide switch on the valve is in the **ON** (I) position.
2. Place the unlocked handset near the fire (ideally within 1 metre).
3. Simultaneously press and hold the **+** and **-** buttons on the valve, the red light on the valve should begin to flash rapidly.
4. Immediately release the **+** and **-** buttons, and press the power button (marked **⏻**) located directly below. N.B. the power button must be pressed within 1 second of releasing **+** and **-** buttons.
5. If steps 3 and 4 are completed correctly, the handset will produce an audible tone, the green light will be flashing, and the display will show **1-1**, the pairing must now be accepted within 60 seconds.
6. To accept pairing pick up the handset and hold firmly to unlock, press and hold **SET** for a few seconds.
7. The handset will beep, and the display will enter the **SETUP** menu.
8. Keeping hold of the handset, it is now possible to set the display functions.
9. Pressing **SET** will advance through the menus, and pressing **MENU** returns to previous options. Use **+** or **-** to change the variables.
10. When setup is completed, **📶** will be visible on the screen. This indicates the handset is in fire operation mode, and has established good communication with the valve.

IMPORTANT NOTE: Even if setup is not completed in full, the handset will still remember the pairing with the Gas Control Valve. The handset will re-enter setup mode the next time it is unlocked, or by manual selection of the setup mode. **DO NOT RE-SEND PAIRING REQUEST FROM VALVE.** This will then require a further reset of handset, and completion of a new pairing process.

GENERAL NOTES ON THE REMOTE HANDSET.

THE FOLLOWING GENERAL NOTES MAY BE OF INTEREST.

The communication symbol **📶** will not be visible on the display if any of the below situations occur:-

- The handset is paired correctly but is out of range of the gas fire control.
- The batteries in the gas fire control are flat, or have bad connections.
- The slide switch on the gas fire control is in the **OFF** (0) position.
- The handset pairing has been broken.

The display will show only the time, day of the week, handset temperature, and handset battery state. The handset will not control the fire if the communication symbol **📶** is absent.

Remedy as above to re-establish handset control of fire.

4. Servicing

Turn the appliance OFF and isolate the gas supply. Ensure the appliance is fully cold before attempting to start servicing the appliance. No liability can be accepted by AGA Stoves for injury caused by burning or scolding by a hot appliance.

A suggested only procedure for servicing is listed below.

- A. Lay out dust sheet on flooring, mask off any special fireplace materials.
- B. Open Outer Firebox Door and remove inner glass panel
- C. Carefully remove the Ceramic components (including Embers)
- D. Use a Vacuum cleaner to clean the top of the burners and grate
- E. Remove the 2 Part Grate
- F. Use the vacuum cleaner and a soft brush to clean the pilot assembly and Injectors. It may be easier to access the Injector by removing the Throttle. Never modify or bend the Thermocouple.
We recommend the pilot assembly is replaced every 12 months during the service
- G. Clean the Window Panel.
- H. Turn on the gas supply and check for leaks, check the burner and Pilot for good condition and Operation – with a strong pilot flame
- I. Replace the Grate front and back
- J. Replace the Fire bed arrangements as per the approved layout
- K. Check inner glass seal, replace if damaged, replace glass frame, do not over tighten the screws
Close door. – please ensure no finger prints are on the glass
- L. Check the flue system and terminal, making sure that the terminal vent is fully clear
- M. Light the appliance and test setting pressures
- N. Check the safe operation of the appliance.

4.1 Cleaning the Ceramics

Remove the ceramics as detailed in A - C above.

Gently clean the ceramics in the open air, using a soft brush and a vacuum cleaner. Where necessary replace damaged components only with genuine AGA Stoves specified parts. Seal any scrap ceramics in plastic bags and dispose of at a proper refuse site. When using a vacuum cleaner, it is recommended that one with a HEPA filtering system is used. The ceramic Log set & Embers contains RCF's

Re-fit the Fire bed arrangement, re-seal the appliance and check the safe operation of the appliance.

4.2 Servicing the Burner

A fault finding codes are included in this manual for the control system fitted to this appliance.

Access the Burner as detailed in A - E above.

The pilot is now clearly visible, the pilot, including the Thermocouple, can be replaced/serviced by removing raising the pilot assembly from its mounting. This is done by removing the two screws on the surface of the pilot. The fittings on the under-side of the pilot can be un-done using a 10mm spanner where appropriate. **We recommend the pilot assembly is replaced every 12 months during the service, this unit covers the thermocouple, pilot light and igniter unit complete**

The Main Burner Injector can be accessed from the underside of the appliance. If the burner needs to be removed, this may be done by removing the 4 x M5 fixings inside the firebox, the burner will lift out through the Firebox as one complete unit

When replacing any parts use only original genuine AGA Stoves specified parts otherwise your warranty will not be valid

GAS ENGINEER SERVICING INFORMATION FOR THE GAS CONTROL VALVE & REMOTE CONTROL

IMPORTANT INFORMATION FOR INSTALLERS.

THE INFORMATION CONTAINED IN THIS SECTION IS FOR EXCLUSIVE USE OF QUALIFIED AND APPROVED SERVICE PERSONNEL.

- THE HANDSET IS SUPPLIED PAIRED TO THE VALVE. DO NOT ALTER PAIRING.
- THE HANDSET IS CONSCIOUSLY DESIGNED TO MINIMIZE THE RISK OF ACCIDENTAL OPERATION AND CAN THEREFORE TAKE A MINIMAL TIME TO LEARN TO USE COMFORTABLY.
- PLEASE EXPLAIN TO THE CUSTOMER TO ENSURE UNDERSTANDING OF HOW TO USE THE REMOTE CONTROL AND MANUAL OPERATION OF THE GAS CONTROL VALVE.
- IF PAIRING HAS BEEN INADVERTENTLY ALTERED THE HANDSET WILL NOT WORK, IT WILL NEED A FACTORY RESET – FOLLOW INSTRUCTIONS ON HOW TO RE-PAIR THE HANDSET.

MOST COMMON CAUSES FOR FAULT.

- BATTERIES NEED REPLACING.
- BATTERIES MOUNTED INCORRECTLY.
- CONTAMINATION OF BATTERY CONTACTS & LEAKING BATTERIES (CLEAN WHERE POSSIBLE, REPLACE VALVE/HANDSET IF NECESSARY).
- CONTAMINATION OF PILOT
- CONTAMINATION OF VALVE INTERNALS FROM GAS PIPE PARTICLES.
- FAULTY GAS SUPPLY.
- FAULTY THERMOCOUPLE OR CONNECTIONS.
- CONTAMINATION IN GAS SUPPLY.

SYSTEM OPERATION EXPLANATION.

The Gas Control Valve is one component, containing the gas valve, control electronics, ignition unit, and battery box.

It is a full sequential ignition system (with no standing pilot).

It utilises both a conventional thermoelectric thermocouple, and electronic flame sensing for its operation.

The ignition phase (first 15-30 seconds) operates with the thermocouple excluded from the circuit, subsequently the thermocouple holds the valve magnet open, as per a conventional system. (If the burner stays lit only for this duration, it is a sign of no thermocouple current, or insufficient thermocouple current reaching the valve).

The electronic flame sensing device is in constant operation whilst the valve is in operation.

It is important that, at all times, the pilot flame is in good order, both the thermocouple tip and electrode tip are immersed within the pilot flame, and the ignition cable is undamaged & well connected to the valve.

The handset is not essential for operation, it is a wireless interface, it is not the control.

When problem solving it is important to check operation using the buttons on the valve itself, this should be done in the first case, DO NOT rely on the handset.

Contamination of the gas supply pipe and any damage to the Gas Control Valve, is not covered by the AGA Warranty

GAS CONTROL VALVE (GCV) - ASSESSMENT.

Ensure Stove is cool before commencing any work.

Ensure batteries are new, mounted correctly, and connections are good.

Start with the valve in standby position – slide switch in **ON** (Power Isolator Switch - Sliding) (I) position, red light on valve off, and fire burner also off.

Press the power button, marked ϕ , and hold for approx. 1 second, or until the red LED lights up, then release. This should start the ignition sequence, and within a few seconds a repetitive spark should be produced at the electrode.

The fire may make up to 3 automatic attempts to ignite. Each ignition cycle takes 15-30 seconds, with a pause of approx. 10 seconds between each cycle. Multiple attempts **DOES NOT** signify that there is a fault, each fire and installation is unique, and may account for this.

If the fire fails to ignite after 3 automatic cycles, the red light on the valve will stay permanently lit, indicating valve lockout. A connected display handset will also return the error code E00. To reset the lockout press the power button to return the valve to standby, and try normal start-up process again.

If problem persists, and valve repeatedly goes to lockout, **refer to the Cleaning & Servicing** section. It is possible that the valve has become contaminated with debris, and requires cleaning to restore normal operation.

If the fire does not light and/or...

- There is an error code EXX (where XX is a two-digit number) displayed on the handset.
- The red LED on the valve is flashing like a heartbeat.
- The display handset is showing low battery.

Please then refer to troubleshooting section and error codes section for further information.

Power Isolator Switch (Sliding) this turns the power onto the Gas Control Valve (GCV)

Red Indicator Light

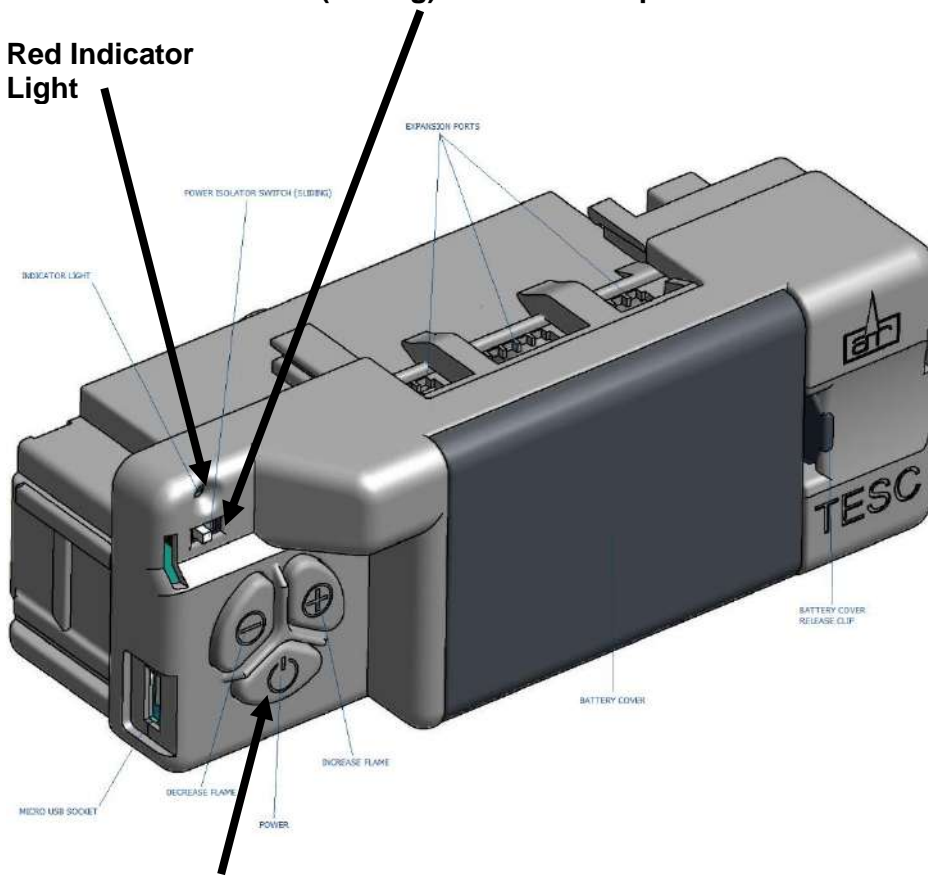

Power ON ϕ Start Button

AGA - GAS CONTROL VALVE (GCV)

ERROR CODES EXPLAINED

Error codes are produced to assist diagnosis of why the fire cannot/will not start. They appear if the control detects abnormal conditions with the fire, environment, installation, components, or internal electronics.

Even if a display handset is not connected, checking for the below faults is still valid. The illuminated red LED on the valve body shows the valve is in error state.

NOTES:

To reset any error, press the power button, marked  on the valve.

False errors can be reported if the batteries are faulty or low on power.

E00
This is the only code where the red indicator LED remains permanently lit without flashing. (N.B. the LED may dim to conserve battery power but remains illuminated).
E00 occurs when fire fails to light after all automatic ignition cycles complete. It is a sign that the electromagnet within the valve has not received enough power from the thermocouple at the end of the ignition cycle. The main burner may light for 15-30 seconds, but then extinguish.
<p>Possible reasons:-</p> <ul style="list-style-type: none"> • Thermocouple not being heated, or being heated too slowly. • No gas to pilot or main burner. • No gas supply, or supply blocked through contamination. • Pilot pipe blocked between valve and pilot. • Pilot injector blocked. • Pilot head damaged or contaminated. • Fire ceramic misplaced causing carbon deposits to contaminate pilots. • Pilot air inlet hole blocked by lint. • No spark at electrode – tracking out somewhere – check for damaged insulation, distance of spark gap, electrode damage, ceramic damage, dirt or soot on electrode. • Flame not touching spark electrode (electrode needs to be in the flame so that valve can sense flame through electrode as well as thermocouple). • Flame signal shorted out (this can occur if any liquids e.g. leak detection spray has contaminated pilot terminals connection). • Spark cable is open circuit (spark may still be present due to ability to jump gaps, but if there is a break in cable, or terminal connection is not good, valve will not receive sensing current – pilot may also light but then continue to spark). • Thermocouple aged or damaged and not producing enough output. • Thermocouple insulation wire is damaged, electrical current shorting (e.g. to body).
NOTE: If stop is pressed during ignition cycle, E00 may also be generated. This is normal, and not a failure condition.
<p>THE VALVE CAN ATTEMPT TO SELF FIX ISSUES – When an E00 code has been displayed an internal recalibration is initiated to attempt to compensate for possible deviations due to contamination, ageing, etc. If the fire does not light on the first ignition cycle, allow the valve to complete the automatic recycles to enable the valve to progress to E00 to recalibrate.</p> <p>Reset error and try again.</p>

E01

Indicates that there is a possibility that the level of CO in ambient atmosphere is too high.

This error will usually be generated when there had been a good electronic flame signal, and the temperature of the thermocouple was hot enough, but has since become cooler.

Possible reasons:-

- Problems with the flue (insufficient air circulation).
- Unstable pilot flame (e.g. wind, unsuitable thermocouple position).
- Contaminated pilot (poor flame to thermocouple).
- Poor position of ceramic parts (e.g. Logs).
- Intermittent failure in thermocouple when hot (inner wire in head perhaps making contact when cold, but not when hot).

E02

Indicates that the ambient temperature around the gas control valve within the fire has exceeded 72°C.

NOTE: This error protects the fireplace and valve from excessive temperatures.

Possible reasons:-

- Faulty installation of the fire (not sealed correctly in fire opening).
- Problems with the Flue (insufficient air circulation).
- Poor position of ceramic parts (e.g. Logs).

NOTE: Batteries do not tolerate high ambient temperatures, eventually this may cause leaking which could damage the valve, meaning a new valve required (not covered under any warranty). Typically the maximum ambient temperature for alkaline batteries is 50°C.

E03

Indicates there is an issue with the thermocouple connection to the valve, or that there is an incorrect reading from the thermocouple.

Possible reasons:-

- No thermocouple connected.
- Thermocouple connection reversed/incorrect.
- Insulated thermocouple wire shorting to chassis earth (damaged insulation).
- Damaged, defective, or worn out thermocouple.

E04

Indicates a flame is detected on pilot **after** valve has shutdown.

Possible reasons:-

- Carbon or other conductive contamination on spark electrode.
- Combustible material burning on pilot near electrode (carbon deposits etc.).

E05
Indicates a flame is detected on pilot before valve has started.
Possible reasons:- <ul style="list-style-type: none"> • Carbon or other conductive contamination on spark electrode. • Combustible material burning on pilot near electrode (carbon deposits etc.).
E06 & E07
Indicates supply voltage is too low to operate valve.
Possible reasons:- <ul style="list-style-type: none"> • Batteries are completely flat (random error codes may also be displayed in this case). • Damaged battery contacts (dirty, corroded, bent – not making strong stable connections). • Short circuit in external wiring or connected accessories. • Defective mains power supply (if used) or damaged wiring. • Problem with internal contacts of slide switch (sliding on/off multiple times may clear this issue). • Batteries mounted incorrectly.
E08, E09, E10, E51
Indicates a device connected to Gas Valve extension socket does not work correctly.
Possible reasons:- <ul style="list-style-type: none"> • If nothing connected – are links missing, in wrong position, or connected badly? • Failure in extension module connected to extension port.
E14, E15, E16, E17
Indicates buttons on valve (or wired control panel) do not work, or are incorrectly wired.
Possible reasons:- <ul style="list-style-type: none"> • Buttons are sticking or blocked. • Buttons are damaged. • Cable damaged, or short circuit to ground (wired control panel).
NOTE: Disconnect wired panel (if applicable) and re-test to determine root cause.
E19, E20, E27, E50, E54, E57, E58, E59, E60, E61
Indicates internal CPU diagnostic self-test has returned invalid results.
Possible reasons:- <ul style="list-style-type: none"> • EMC issue (try twisting ignition cable around thermocouple wire several times to quench radiated EMC emissions). • Spark tracking out somewhere other than at electrode causing unusual interference.
E24
Indicates the thermocouple has not reached nominal final temperature within 1 minute of startup.
Possible reasons:- <ul style="list-style-type: none"> • Aged thermocouple. • Thermocouple wire insulation is damaged and shorting to metal chassis. • Problems with chimney, or room, air inlets (insufficient air circulation). • Unstable pilot flame (e.g. wind, unsuitable thermocouple position). • Contaminated pilot (poor flame to thermocouple). • Poor position of ceramic parts (e.g. coals, logs, or matrix).

E26

Indicates power supply with incorrect pin orientation connected to USB inlet.

E32, E43, E46, E47, E52, E53, E55, E56, E62

Indicates self-test procedure of valve electronics has failed.

Possible reasons:-

- Completely flat batteries.
- Liquid ingress affecting electronics (e.g. following leak test with soapy water).

E33, E34, E35, E36, E37, E38, E39, E40, E41, E42

Indicates internal piston is not moving freely.

Possible reasons:-

- Contamination of valve inlet/outlet with debris from supply pipe or other.
- Mechanical damage of valve.

NOTE: After cleaning and before resetting error codes, ensure fire has been allowed to fully cool. Upon starting the valve will reinitialize and perform a re-calibration. The valve **MUST** be cold to perform this task.

NOTE: If the valve needs to be replaced, ensure to check pipework for contamination prior to fitting new valve to help avoid repeated problems.

E48

Indicates that the control has detected a short circuit of the thermocouple.

Possible reasons:-

- Thermocouple connection reversed/incorrect.
- Insulated thermocouple wire shorting to chassis earth (damaged insulation).
- Damaged, defective, or worn out thermocouple.
- Weak connection from thermocouple to valve.

E49

Indicates valve has detected a false flame signal on electrode.

Possible reasons:-

- Contamination of the electrode with carbon deposits, conductive liquids (leak detection spray), or similar.
- Contamination of thermocouple/valve connection with conductive liquids (leak detection spray), or similar.

NOTE: It is critical to avoid leak detection fluid making contact with any part of the valve other than the threaded pipe connections. Leak detection fluids are highly corrosive and will damage any electronics with which they make contact. Other forms of leak detection should be used where possible.

Cleaning & Servicing the Pilot Assembly – Points to Check!

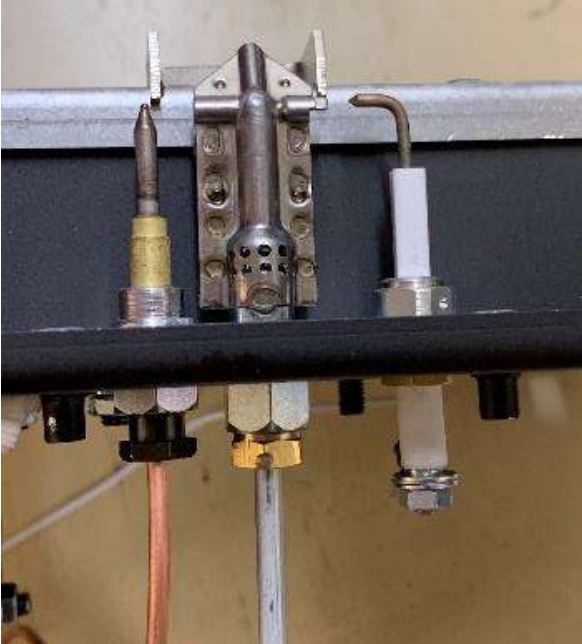
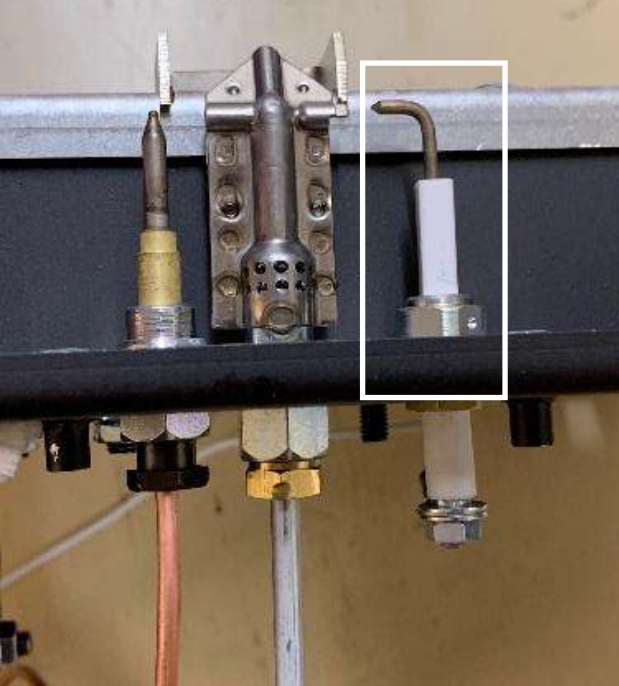
<p>PILOT ASSEMBLY.</p>	
<ul style="list-style-type: none"> • Check for blockage in gas pipe to pilot, or injector inside pilot. • Check for a contaminated pilot assembly. <p>NOTE: The pilot is an integral part of the safe operation of the fire and MUST be changed at every Annual Service to ensure safe operation of the fire, this will also help to reduce the risk of problems during operation. Each pilot is date coded to enable tracking of the age of the pilot. Any warranty will be immediately void if the Pilot Assembly is not changed every 12 months.</p> <ul style="list-style-type: none"> • Cleaning the pilot between services. <p>The pilot must be kept clean of any debris, dust, or contamination. If not, the fire may not light well, and may not light/run at all.</p>	
<p>ELECTRODE – WHITE CABLE</p>	
<ul style="list-style-type: none"> • The electrode consists of an ignition cable, white ceramic body, and a wire tip – these parts must be kept completely clean. • A new, unused, clean, dry paintbrush is recommended for cleaning the pilot assembly and electrode tip. <p>NOTE: Soot deposits which are a carbon contamination that can occur. This is quite common, particularly if the artificial logs have not been laid properly within the stove, or if they have moved during use. This may not appear to be a significant problem, but because of the conductive nature of carbon it is possible that the spark may track out via such deposits and not light the pilot gas flame.</p> <ul style="list-style-type: none"> • If ignition cable insulation becomes damaged, it is unlikely that the spark will reach the pilot burner, and therefore ignition will be prevented. 	 <p style="text-align: center;">Electrode in White box outline</p>

PILOT LIGHT & AIR INLET APERTURE.

- The air intake hole on the pilot are very small and can become contaminated from the ambient environment.
 - Dust can be very hard to see, but even a small amount can stop the fire from lighting.
- During operation, the Flue draws air in from outside, any airborne particles (e.g. dust & pollen) can also be potentially drawn in. The rate at which this occurs depends on a number of environmental factors.
- Cleaning of the pilot is required at least once a year (in between services) but is recommended more regularly.

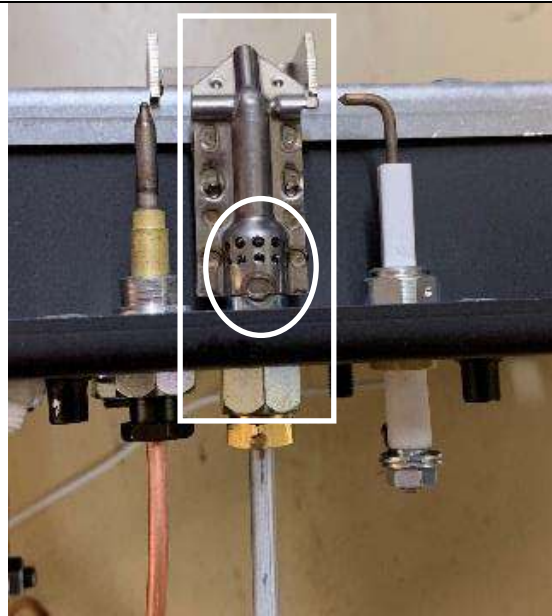

Pilot Light in White box outline

CORRECT POSITION OF THERMOCOUPLE & IGNITER ELECTRODE CONNECTIONS ON THE VALVE

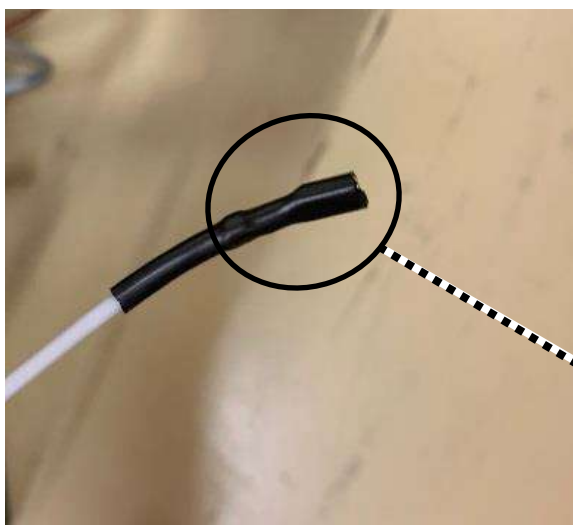

II - WHITE COLOURED IGNITER ELECTRODE CABLE (2) INTO BACK OF THE GAS CONTROL VALVE (GCV)

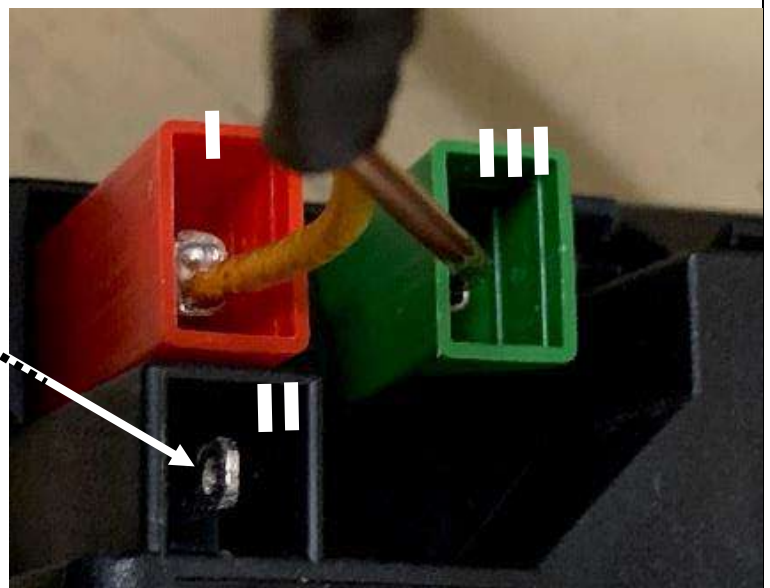

- I - RED THERMOCOUPLE PLUG TO THE OUTER EDGE (1)**
- II - WHITE ELECTRODE CABLE UNDER THE RED PLUG (2)**
- III - GREEN THERMOCOUPLE PLUG TO THE INSIDE PLUG WHICH IS NEAREST TO THE GAS FEED PIPE (3)**



WHERE TO OBTAIN SPARES - All spare parts for this stove must be purchased from your retailer or directly from AGA Spares, only Genuine AGA spares can be used for you Warranty to be valid

CORRECT POSITION OF THERMOCOUPLE & IGNITER ELECTRODE CONNECTIONS ON THE VALVE

		<p>Gas Feed to Burner Test Point/Burner Unit</p> <p>Pilot Assembly Gas Feed</p> <p>Gas Inlet Pipe</p> <p>III - Green Thermocouple Cable Plug (3)</p> <p>I - Red Thermocouple Cable Plug (1)</p> <p>II - White Igniter Electrode Cable Plug (2)</p>
<p>I - RED THERMOCOUPLE PLUG TO THE OUTER EDGE (1)</p> <p>II - WHITE ELECTRODE CABLE (2) UNDER THE RED PLUG</p> <p>III - GREEN THERMOCOUPLE PLUG (3) TO THE INSIDE PLUG WHICH IS NEAREST TO THE GAS FEED PIPE</p>	<p>REAR VIEW OF GAS CONTROL VALVE (GCV)</p>	

WHERE TO OBTAIN SPARES - All spare parts for this stove must be purchased from your retailer or directly from AGA Spares, only Genuine AGA spares can be used for you Warranty to be valid

Checking the Batteries – When Should I Change the Batteries

Battery Information.	
<p>If a display handset is paired with the valve, the display will show the battery level in both the valve and the handset (by toggling between FC [fire control – fitted in the Gas Control Valve (GCV) – which is accessed at the bottom front of the stove] and RC [remote control]).</p>	
	<ul style="list-style-type: none"> • Battery symbol shows full battery indication and letters FC – meaning the Fire Control batteries are in good condition. THESE ARE THE BATTERIES IN THE GAS CONTROL VALVE (GCV) • Usually the fire will function normally until only 1 bar is shown by the battery indicator icon. If in any doubt, it is recommended that batteries are changed as soon as possible. • NOTE: Pairing is not lost if the batteries run out, or are removed, however the time setting on the handset will be lost, and will need to be reset.
	<ul style="list-style-type: none"> • Battery symbol shows empty battery indication and letters RC – meaning the Remote Control batteries are in need of being changed. • If letters FC are displayed, the batteries in the Fire Control valve need changing. THESE ARE THE BATTERIES IN THE GAS CONTROL VALVE (GCV) • If fire does not light, the best course of action is to change the batteries for known good (preferably new) batteries before doing anything else.

Leaking Batteries.

- If batteries leak and damage the valve (or handset) this is not a fault of the valve or gas fire.
- To minimize the risk of battery leakage, the batteries should be changed well before they are completely empty, and at a minimum once every 12 months as a preventative measure.
- Although any brand of alkaline AA battery can be used, some are known to be better than others. We recommend **ENERGIZER OR DURACELL** batteries, as they have performed well under test conditions, store power well, and claim to be more resistant to leaking than competitor products.
- **DO NOT USE RECHARGABLE BATTERIES**
- **We recommend if you are not going to use the stove for a period of time greater than 12 weeks remove the batteries from the Gas Control Valve and the remote control to avoid leaking**

PLEASE NOTE – AGA STOVES TAKES NO RESPONSIBLIY FOR INCORRECT BATTERIES BEING USED, DAMAGE TO THE CONNECTORS WHEN FITTING THE BATTERIES OR LEAKING BATTERIES OR ANY DAMAGE TO THE REMOTE CONTROL OR THE VALVE BECAUSE OF LEAKING BATTERIES OR DAMAGED CONNECTOR. THIS IS NOT COVERED BY ANY WARRANTY OFFERED ON THIS STOVE BY AGA STOVES

5.0 Technical Data - *Product Identification Number: 0359DL05893* Ellesmere & Ludlow LPG Gas Single Burner – Wide Model ECGW

Description	Measurement	Tolerance Allowed
Gas Type	LPG Gas	N/A
Supply Pressure (incoming)	37.5 mbar	+/- One mbar
Nominal Heat Input Gross (Hs)	9.40 kW	+/- 5%
Nominal Heat Input Nett (Hi)	8.63 kW	+/- 5%
Consumption Rate	10.0 l/min (Litres per Minute)	+/- One l/min
Burner Pressure (Hot)	25.3 mbar	+/- 1.5 mbar
Pilot	446.1385.44	N/A
Efficiency Class	1	N/A
Nox Class	5	N/A

Using the AGA TESC Control Valve System - Maximum High Heat Stove Output - 7.0 kW

This CE plate is found at the back of the stove at the bottom

The Aluminium serial plate for the stove is found if you open the front door and it is on the left hand side above the bottom hinge mount. It is a small aluminium plate with a number printed onto it

Checking & Testing the Stove after Installation - Undertaking as a minimum the 8 x tests and checks listed below on the stove after installation, all testing and checking must be in compliance with the latest Building Regulations and Gas Safe requirements

- 1 - Gas Tightness Test** - Now carry out a Gas Tightness Test on the appliance installation
- 2 - Checking the Burner Pressure** - Once the stove has run hot for a minimum of 5 minutes and you have checked the HOT burner pressure from the test point under the burner.
- 3 - Gas Safety Device Test** - Turn the Gas off to the stove using the Test Point On/OFF Tap that you have fitted to the rear or side of stove, ensure no gas is able to enter the stove
Then attempt to re-light the stove using the remote control handset, after 3 attempts to re-light the stove the remote handset should then show an error code on the display of E00. If this code appears in the handset it has passed the Safety Test
To reset the E00 error, press the power button, marked  on the on the valve
- 4 - Check the Supply Inlet Pressure** in mbars
- 5 - Check the Nominal Heat Input Gross (Hs)** in kW
- 6 - Check the Nominal Heat Input Nett (Hi)** in kW
- 7 - Check the Gas Consumption Rate** in l/min
- 8 – Only the AGA specified flue system & layout can be used for this installation**

The above checks & tests are the minimum requirement, it is the responsibility of the Gas Safe (qualified engineer) who is undertaking the installation, to ensure the stove installation is safe and meets the latest Building Regulations and Gas Safe regulations and requirements

5.1 Exploded View of the Stove Ellesmere & Ludlow Wide – Model ECGW

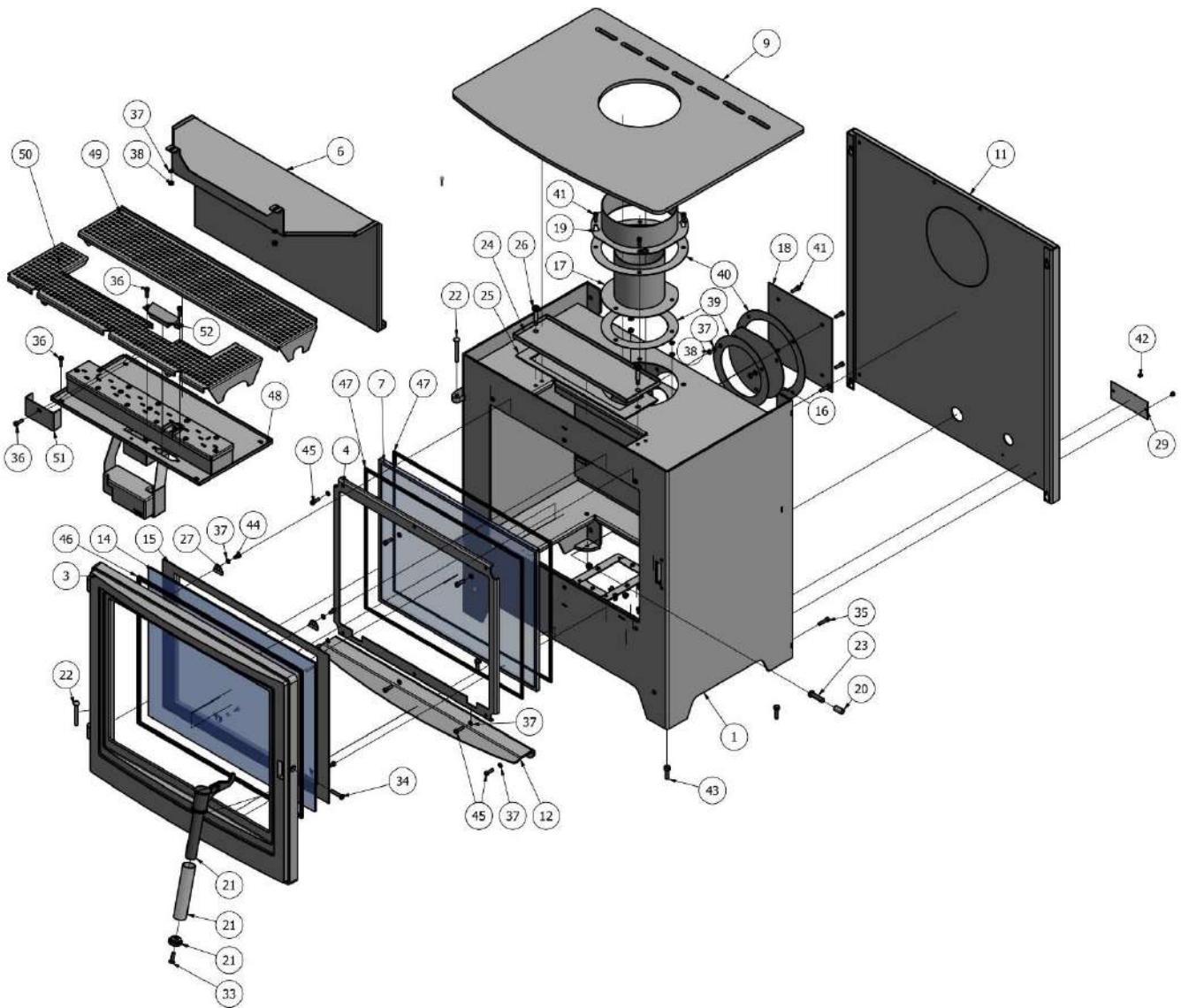

Gas Burner & LPG Gas Valve Controller - Spare Parts

Part No	QTY	DESCRIPTION	Part No	QTY	DESCRIPTION
ECGW 9001	1	Ceramic Log Pack – 11 pieces	ECGW 9007/LPG	1	Pilot Assembly LPG
ECGW 9002	1	Ember Pack	ECGW 9008/LPG	1	LPG Injector - Burner
ECGW 9003	1	Remote Handset			
ECGW 9004/LPG	1	Gas Valve Controller – LPG			
ECGW 9005 OR ECGW/ ELL /041/LPG	1	Complete Burner Assembly LPG Wide Model			
ECGW 9006	1	AGA Approved Mains Adapter			

Stove Parts List overleaf

5.1 Parts List Details

NO	QTY	Part Number	DESCRIPTION	NO	QTY	Part Number	DESCRIPTION
1	1	ECGW/ELL /001	GA5-01 Main Stove Body ECGW	27	4	ECGW/ ELL /024	Glass Clip
2	0	N/A	N/A	28	0	N/A	N/A
3	1	ECGW/ ELL /002	AGA Stoves Cast Door EC5W	29	1	ECGW/ ELL /025	EC GW CE Plate
4	1	ECGW/ ELL /003	Inner Glass Frame ECGW	30	0	N/A	N/A
5	1	ECGW/ ELL /004	Baffle Assy ECGW	31	0	N/A	N/A
6	1	ECGW/ ELL /005	Baffle Cover Plate ECGW	32	0	N/A	N/A
7	1	ECGW/ ELL /006	Inner Glass ECGW	33	1	ECGW/ ELL /026	M6 X 20mm Countersunk socket screw
8	0	N/A	N/A	34	1	ECGW/ ELL /027	M6 X 30mm Countersunk socket screw
9	1	ECGW/ ELL 007	Stove Lid ECGW	35	4	ECGW/ ELL /028	M5 X 20mm Cap socket screw
10	0	N/A	N/A	36	9	ECGW/ ELL /029	M5 X 12mm Cap socket screw
11	1	ECGW/ ELL /008	Back Panel	37	25	ECGW/ ELL /030	M5 Spring washer
12	1	ECGW/ ELL /009	Front Ash Lip	38	16	ECGW/ ELL /031	M5 Nut
13	0	ECGW/ ELL /010	N/A	39	2	ECGW/ ELL /032	100mm Flue Seal
14	1	ECGW/ ELL /011	Outer Door Glass ECGW	40	2	ECGW/ ELL /033	150mm Flue Seal
15	1	ECGW/ ELL /012	EC GW Inner Frame	41	8	ECGW/ ELL /034	M5 X 15mm Cap socket screw
16	1	ECGW/ ELL /013	100mm Blanking Plate	42	2	ECGW/ ELL /035	3.2 x 6mm Steel Rivet
17	1	ECGW/ ELL /014	100mm Spigot Weldment	43	4	ECGW/ ELL /036	M6 X 20mm Hex set screw/Leveling Bolt
18	1	ECGW/ ELL /015	150mm Blanking Plate	44	4	ECGW/ ELL /037	M5 X 8mm Cap socket screw
19	1	ECGW/ ELL /016	150mm Spigot	45	4	ECGW/ ELL /038	M5 X 12mm Cap socket screw
20	1	ECGW/ ELL /017	Door Handle Roller	46	1	ECGW/ / ELL /039	ECGW Glass Gasket
21	1	ECGW/ ELL /018	Cast Handle Complete	47	2	ECGW/ ELL /040	EC GW Glass Gasket
22	2	ECGW/ ELL /019	M6 X 50mm Hinge Pin	48	1	ECGW/ ELL /041 OR ECGW 9005	Single Ellesmere & Ludlow Wide Burner Complete
23	1	ECG/ ELL /020	M8 x 30mm Dome socket screw	49	1	ECGW/ ELL /042	EC GW SINGLE Grate A part
24	1	ECG/ ELL /021	Delayed Ignition Flap Folding	50	1	ECGW/ ELL /043	EC GW SINGLE Grate B part
25	1	ECG/ ELL /022	Delayed Ignition Flap Gasket	51	1	ECGW/ ELL /044	Pilot Shield Lower
26	2	ECG/ ELL /023	M6 X 25mm 8mm Shoulder Bolt	52	1	ECGW/ ELL /045	Pilot Shield Upper

5.2 Warranty Details

AGA Stoves - Balanced Flue Gas Stove – 2 Year Warranty

It's important to know what requirements need to be met in order to qualify for our 2 year warranty, as well as being aware of exactly what it covers. This warranty only applies to our gas balanced flue stoves.

If you have purchased your stove from an authorised stockist within our Premium Retailer Network, then automatically your product will carry a 2 year warranty. The start date for the warranty period is the date of purchase. You do not need to register your stove for the warranty to apply, but you must retain your proof of purchase from the AGA retailer, which must have your name, address and the date of the purchase. Plus a copy of the Local Authority **BUILDING REGULATIONS COMPLIANCE CERTIFICATE**. Then from the serial number on your stove we can then action your warranty, you must have the stove serviced every 12 months and keep the service receipt for the warranty to be valid. Any product purchased outside of our Premium Retailer Network will carry a standard 12 month, non-extendable warranty.

It is a condition of the Warranty that the installation complies with relevant Building Regulations and the rules in force, and is carried out by a suitably trained and qualified individual Gas Safe registered in the United Kingdom (or equivalent in other countries) with a certificate of installation and the appropriate commissioning report completed and retained by the end-user. Please refer to Appendix 1 & 2 overleaf

It is also a condition of the Warranty that your AGA Stove is regularly serviced (every 12 months) by a suitably trained and qualified individual, Gas Safe registered in the United Kingdom (or equivalent in other countries). Records and receipts of annual services will be required in the event of a warranty claim during the period of the warranty.

This warranty is not transferable, and solely for, the benefit of the original purchaser of the stove. Please retain your dated sales receipt as a proof of purchase.

During your warranty period, only genuine AGA spare parts must be used in the servicing and maintenance of your stove, these spare parts can be ordered via the Premium Retailer directly.

Consumable items such as glass, paint, grate parts, log retainers, thermocouples, pilots lights, igniters, ceramic fuel effects, internal linings, batteries and rope seals which are either subject to normal wear and tear or parts that require replacement in connection with normal maintenance are not covered, either by the Warranty. The Flue system is not covered by any warranty from AGA Stoves.

Should you experience problems with your stove, any claim must be submitted first to the Premium Retailer from where the stove was purchased. Your Premium Retailer will either be able to offer immediate assistance or make contact with AGA Stoves on your behalf.

Warranty Exclusions and Limitations

No Warranty is extended to consumable service parts. Repair or replacement of parts which are subject to normal wear and tear during the warranty period or parts that will require replacement in connection with normal maintenance. Such parts include but are not limited to glass, paint, rope seals, grate parts, log retainers, thermocouples, pilots lights, igniters, ceramic fuel effects, batteries and internal linings.

The AGA Stoves Warranty does not cover:

- a) In normal usage the paint finish of your AGA Stove may change colour slightly. As these circumstances are considered normal, they are not covered by the warranty. The stove paint must be cured as detailed in this manual
- b) Enamelled components where these parts are subjected to abnormally high temperatures, chemical abrasion or thermal shocks, resulting in chipping, cracking, bubbling or discolouration and crazing of the enamelled finish.

- c) Damage resulting from installation and usage where the appliance has not been installed or used in accordance with the AGA Stoves installation and operation instructions, or if the installation does not conform to local building, fire and safety regulations. This includes the entire flue system whether purchased from AGA Stoves or not
- d) Defects or faults caused by specific local conditions such as draught problems, water damage, condensation and chimney defects.
- e) The Warranty does not cover damage caused by over-firing of the appliance. (Please see your Installation and Operating Instructions for further information)
- f) The entire flue system
- g) Misuse of the remote control including water/liquid/heat damage
- h) Damage caused by unauthorised modifications, use or repair.
- i) Damage or defects caused by the product being stored in a damp, unheated environment.
- j) Consequential loss (to the extent permitted by law) relating to other associated products that have not been supplied by AGA Stoves.
- k) Consequential loss (to the extent permitted by law) related to decorations, furnishings or other household assets.
- l) Delivery to/or return transport costs. Removal and re-installation costs, or any labour cost to fit parts. Repaired or replaced products are covered only for the remainder of the original warranty period. If you should ever wish to make a warranty claim because of a product fault or defect, you must inform your retailer within a reasonable amount of time, this is within 14 days from the date on which the fault or defect first became apparent. If the product fault or defect is notified after 14 days from the date on which the fault or defect became apparent, AGA Stoves cannot accept any liability for events or issues which arise after the 14 day period or which are caused or increased by the lack of notification which therefore prevented action being taken to restrict or eliminate any consequences arising from the fault or defect at an earlier date.
- M) Takes no responsibility for incorrect batteries being used, damage to the connectors when fitting the batteries or leaking batteries or any damage to the remote control or the valve because of leaking batteries or damaged connector.
- N) Any foreign bodies found in the Gas Control Valve – including Brick Dust

In the event of a product fault occurring during the warranty period, AGA Stoves will send the appropriate component or goods necessary to rectify the fault, free of charge, but does not cover any labour cost to fit them.

Nothing in the Warranty shall make AGA Stoves liable for any or special, incidental or consequential damages, injury to persons or property, or any other consequential loss beyond the consumer's statutory rights. The liability on these issues is covered by AGA Stoves Terms and Conditions of Sale.

AGA Stoves' total liability extends only to the purchase price paid for the goods by the Premium Retailer, The AGA Stoves Warranty does not affect your statutory rights.

The above warranty terms and conditions came into effect on 1st January 2013 and are applicable for all relevant products purchased after this date.

Please note: This warranty is applicable for purchases within the United Kingdom and the Republic of Ireland

Appendix 1 - Appliance Commissioning Checklist & Customer Sign Off

Section 1 to 3 - to be completed by the Gas Safe Engineer

Section 4 & 5- to be completed by the Customer & the Gas Safe Engineer

SECTION 1 - FLUE CHECKLIST		YES	NO
Is the Flue correct for appliance?			
Has the flue been checked for its soundness & all the locking bands are fitted on all joints?			
Have the inner and outer Flue Collars been fitted correctly & gasket seals all ok?			
Have the 2 x Locking Screws been fitted into the flue collar to secure the flue to the stove?			
Has a Wire Basket been fitted to the outside Horizontal Terminal on the wall?			
SECTION 2 - GAS CHECKLIST		YES	NO
		<i>Please write in here the Mbar Measured</i>	
Gas Soundness / Tightness Test – All joints fully tested for any leaks?		N/A	
ON/OFF Tap with Pressure Check Point be fitted to the outside of the stove?		N/A	
COLD Standing Gas Pressure (Mbar) – Inlet Pressure tested at the above ON/OFF Tap with Pressure Check Point?			
Appliance Burner Working Pressure (on HIGH FLAME Setting – HOT Stove) NB All other gas appliances in the house must be operating on full power at the same time (Mbar)?			
Pilot Assembly – Thermocouple, Pilot flame & Igniter Electrode are all plugged in to the valve, checked & working correctly with a strong straight pilot flame?		N/A	
Carried out the 8 x Installation Tests & Checks refer to S. 5.0 Technical Data		N/A	
SECTION 3 - SAFETY CHECKLIST		YES	NO
Glass checked to ensure no damage, scratches, scores, fingerprints or cracks?			
Inner glass frame secured correctly & QTY 6 x screws replaced, seal fitted either side of glass all ok? But have not been overtightened?			
Ceramic Logs and embers have been fitted correctly? – Not covering the thermocouple area?			
Relief Valve Flap (RVF) on the top of the stove & gasket are fitted correct and RVF is fully closed position?			
Gas Control Valve (GCV) all working correctly – remote hand set paired & fully working?			
Rear Chain has been fitted to the stove to prevent tipping or movement?			
Door is in the fully closed position, Handle has been locked off with Grub Screw			
SECTION 4 - CUSTOMER HAND OVER CHECKLIST		YES	NO
Customer fully understands how to use the remote control?			
Customer understands all of the functions of the stove?			
Customer is given this copy of the Operating Manual?			
Customer understands how to fit new batteries into the Gas Control Valve at the front of the stove and also in the remote handset?			
Customer Understand where the gas shut off valve is installed for the stove?			
Customer knows how to work the stove in the manual mode using the Gas Control Valve (GCV) and how to turn the GCV off with the sliding switch & understand that the stove becomes very hot at the front when in operation? – The front hot zone?			
Customer has no issues with the stove & how to operate it?			
SECTION 5 - CUSTOMER SIGN OFF	GAS SAFE ENGINEER SIGN OFF		
Customer Name:	Gas Safe Engineer Full Name:		
Customer Signature:	Gas Safe Engineer Signature:		
Date:	Date:		
	Gas Safe Engineer Registration Number:		

Appendix 2 - Annual Servicing Records & Date Batteries are Changed (Valve & Remote)

For your warranty to be valid you must have this stove serviced once a year by a Gas Safe Registered Engineer who is qualified to service gas balanced flue stove, please record the details here and attach your invoice as proof of service

Annual Service Record – Year 1	Annual Service Record – Year 2	Annual Service Record – Year 3
Name of Gas Safe Register Engineer who completed the service	Name of Gas Safe Register Engineer who completed the service	Name of Gas Safe Register Engineer who completed the service
Telephone & Email Contact Details	Telephone & Email Contact Details	Telephone & Email Contact Details
Engineers Gas Safe Registration Number	Engineers Gas Safe Registration Number	Engineers Gas Safe Registration Number
Date of Service	Date of Service	Date of Service
Cost of Service	Cost of Service	Cost of Service
Glass Seal Replaced on Inner Glass YES or NO – please circle which one	Glass Seal Replaced on Inner Glass YES or NO – please circle which one	Glass Seal Replaced on Inner Glass YES or NO – please circle which one
Other Notes	Other Notes	Other Notes
Pilot Assembly Changed Y / N Battery Changed in Gas Valve Y / N Battery Changed in Remote Y / N	Pilot Assembly Changed Y / N Battery Changed in Gas Valve Y / N Battery Changed in Remote Y / N	Pilot Assembly Changed Y / N Battery Changed in Gas Valve Y / N Battery Changed in Remote Y / N
Annual Service Record – Year 4	Annual Service Record – Year 5	Annual Service Record – Year 6
Name of Gas Safe Register Engineer who completed the service	Name of Gas Safe Register Engineer who completed the service	Name of Gas Safe Register Engineer who completed the service
Telephone & Email Contact Details	Telephone & Email Contact Details	Telephone & Email Contact Details
Engineers Gas Safe Registration Number	Engineers Gas Safe Registration Number	Engineers Gas Safe Registration Number
Date of Service	Date of Service	Date of Service
Cost of Service	Cost of Service	Cost of Service
Glass Seal Replaced on Inner Glass YES or NO – please circle which one	Glass Seal Replaced on Inner Glass YES or NO – please circle which one	Glass Seal Replaced on Inner Glass YES or NO – please circle which one
Other Notes	Other Notes	Other Notes
Pilot Assembly Changed Y / N Battery Changed in Gas Valve Y / N Battery Changed in Remote Y / N	Pilot Assembly Changed Y / N Battery Changed in Gas Valve Y / N Battery Changed in Remote Y / N	Pilot Assembly Changed Y / N Battery Changed in Gas Valve Y / N Battery Changed in Remote Y / N

Appendix 3 - Energy Efficiency Labels

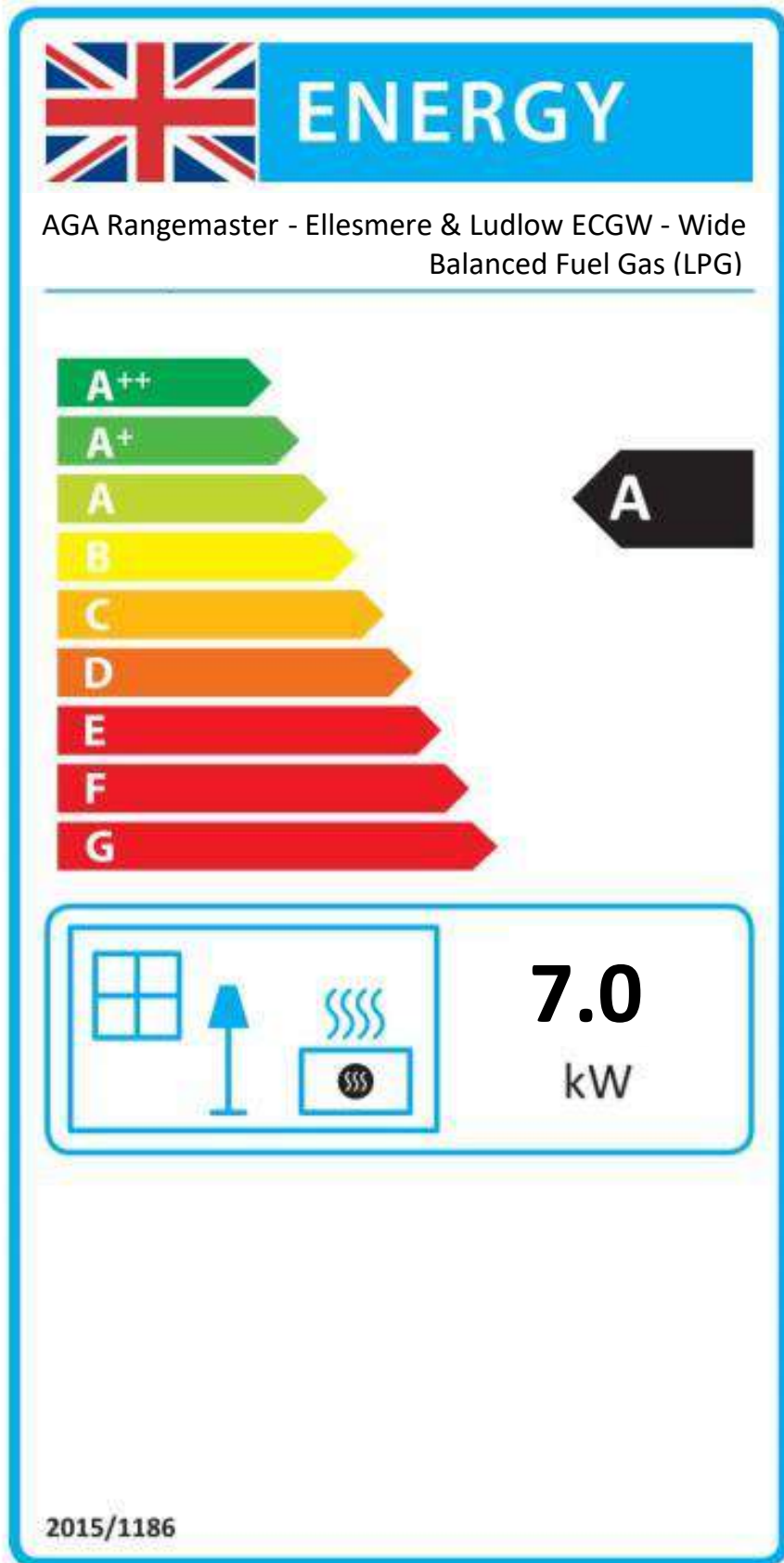

UK Version



ENERG Y IJA
енергия · ενεργεια IE IA

AGA Rangemaster - Ellesmere & Ludlow ECGW - Wide
Balanced Fuel Gas (LPG)

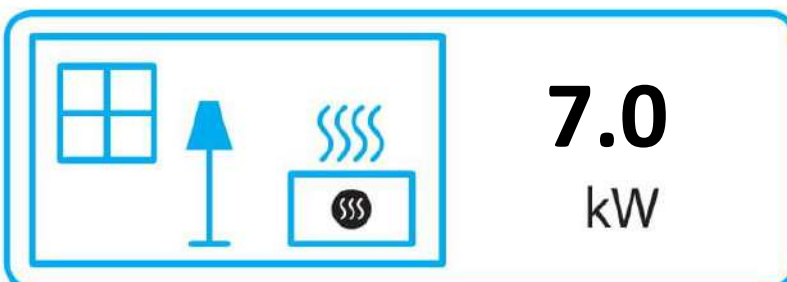

ENERGIA · ЕНЕРГИЯ · ΕΝΕΡΓΕΙΑ · ENERGIJA · ENERGY · ENERGIE · ENERGI

2015/1186

With AGA Rangemaster's Policy of Continuous Product Improvement, the Company reserves the right to change specifications and make modifications to the appliance described and illustrated at any time



AGA Rangemaster
Station Road, Ketley
Telford, Shropshire
TF1 5AQ
United Kingdom
www.agastoves.co.uk



**This Stove is
Manufactured
in the UK**



Certificate Number:
UK-LHD-0359-0005893

Product Identification Number:
0359DL05893

This is to certify that the appliances listed have been examined and found to comply with the essential requirements listed in:

Annex I of European Council Regulation (EU) 2016/426 of 9th March 2016 relating to appliances burning gaseous fuels.