

Contura

110



Facts	3
Installation distances	4
Declaration of performance	5
EU Declaration of Conformity	6
Assembly	7

Facts



5 kW

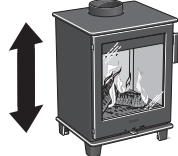

565 mm



430 mm



375 mm



65 kg

Nominal effect	5 kW
Efficiency	79%
Flue gas mass flow	4,2 g/s

Meets requirements of:
European standard EN-13240
Clean Air Act. 61534 (UK)



The stove becomes very hot

During operation, certain surfaces of the stove become very hot and can cause burn injury if touched. Be aware of the strong heat radiated through the hatch glass. Placing flammable material closer than the safe distance indicated may cause a fire. Pyre lighting can cause quick gas ignition with the risk of damage to property and personal injury.

Installation by authorised technician

This manual contains instructions about how the stoves must be assembled and installed. To ensure the function and safety of the stove, the installation should be carried out by a Hetas trained engineer. Contact one of our dealers who can recommend suitable installer. When completed, the installer should inform the local Council/ authority about the new installation.

Building application

These main instructions may give guidance which would contravene national building regulations. Please refer to supplementary instructions or ask your local authority for advice regarding building regulations.

Before installing a stove or erecting a chimney it is necessary for you to make a building application permission to your local authority.

The owner of the house is personally responsible for ensuring compliance with the mandatory safety requirements and must have the installation approved by a qualified inspector. Your local chimney sweep must also be informed about the installation as this will affect the routines for regular chimney-sweeping services.

Structural support

Check that the wood joists are strong enough to bear the weight of the stove and chimney. The stove and chimney can usually be placed on a normal wooden joist in a single occupancy house if the total weight does not exceed 400 kg.

Hearth plate

Due to the risk of falling embers, a flammable floor must be protected by a hearth plate. It must extend 300 mm in front of the stove and 100 mm on each side of the stove, or have a 200 mm extension on each side of the opening. The hearth plate can consist of natural stone, concrete, metal plate or glass.

Final inspection of the installation

It is extremely important that the installation is inspected by an authorised chimney sweep before the stove is used. Also read the "Lighting instructions", before lighting for the first time.

Connection to chimney

- The stove must be connected to chimneys dimensioned for a minimum flue gas temperature of 400°C.
- The stove should not be installed in a chimney serving more than one appliance.
- The diameter of the connection sleeve is designed to fit chimney pipes with an external diameter of Ø125 mm. A connection sleeve is available, as an optional extra, for chimney pipes with an internal diameter of Ø150 mm.
- Normal chimney draw under nominal operation should be between 20-25 Pa close to the connector. The draft is affected both by the length and area of the chimney, and by how well sealed it is. The recommended minimum flue length is 3.5 m and its diameter should be Ø125 to Ø150 mm.
- A flue with sharp bends and horizontal routing reduces the draught in the chimney. Maximum horizontal flue is 1 m, on the condition that the vertical flue length is at least 5 m.
- It must be possible to sweep the full length of the flue and the soot hatches must be easily accessible.
- Carefully check that the chimney is sealed and that there is no leakage around soot hatches and flue connections.

Supply of combustion air

When a stove is installed in a room, the demand for air supply to the room increases. Air can be provided indirectly via a vent in the outer wall or via a duct from the outside that is connected to the connector on the underneath of the stove. The amount of air needed for combustion is 20 m³/h.

The connector (accessory) for the combustion air has an external diameter of 80 mm. When duct routing further than 1 m the pipe diameter must be increased to 100 mm and a correspondingly larger wall vent must be selected.

In hot areas, the duct should be insulated with 30 mm mineral wool with a moisture inhibiting outer cover. It is also important to seal around the hole in the wall (or floor) of the lead-in using sealant.

A 1 m length of condensation insulated ducting for combustion air is available as an accessory.

Installation distances

The minimum distance in front of the stove opening to combustible parts of the building or interior decoration must be at least 1,1 m.

The dimension diagrams only show the minimum permitted installation distances for the stove. When connecting to a steel flue, also note the safety distance requirements of the flue. The safety distance between an uninsulated flue and a combustible part of the building should be at least 500 mm.

- A = height from floor to chimney connection upwards
- B = height from floor to c/c chimney connection rear
- C = height from floor to air inlet

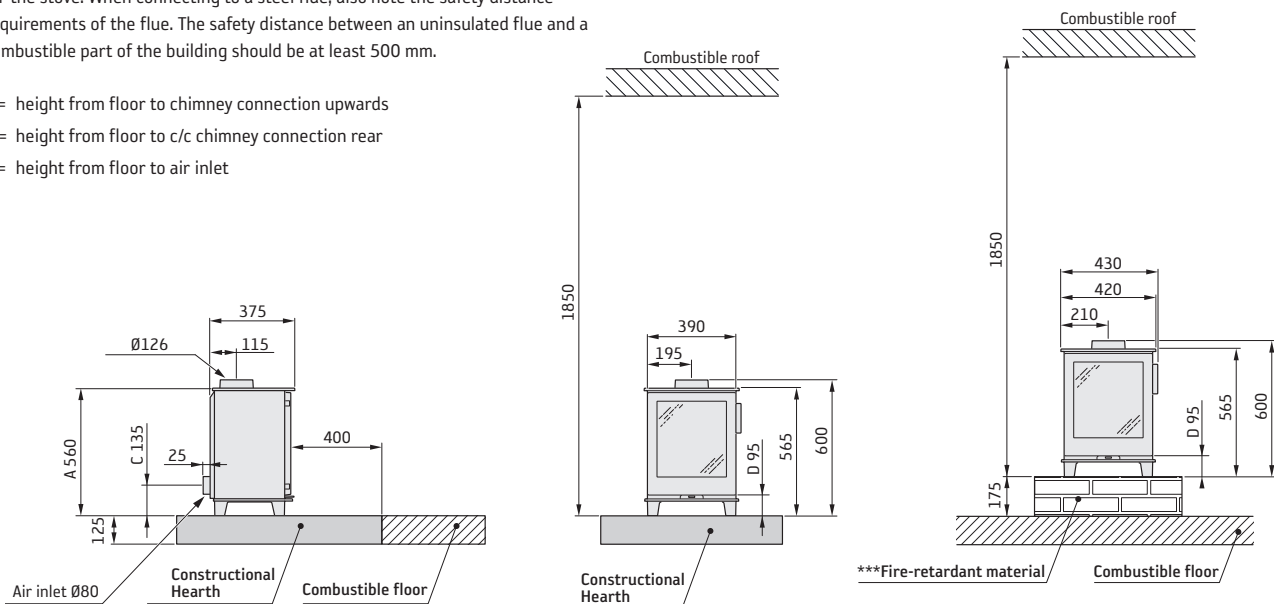

INSTALLATION AGAINST COMBUSTIBLE WALLS

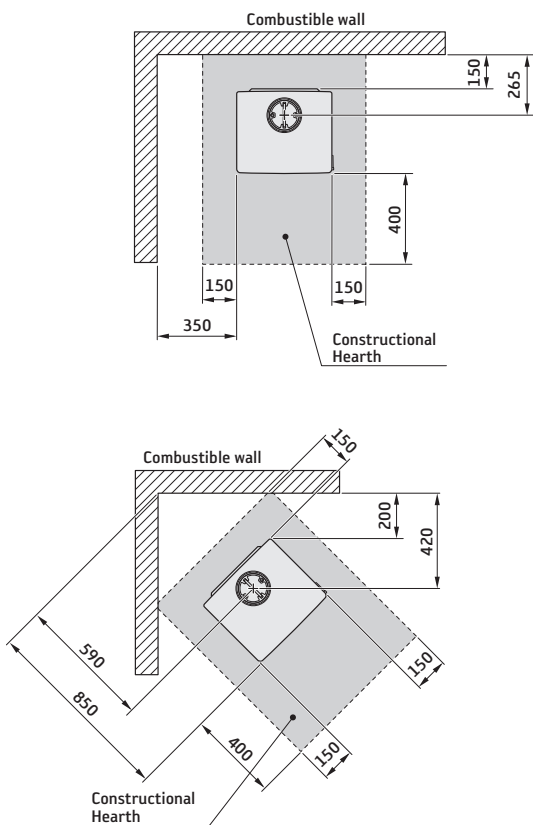

INSTALLATION AGAINST FIREWALLS

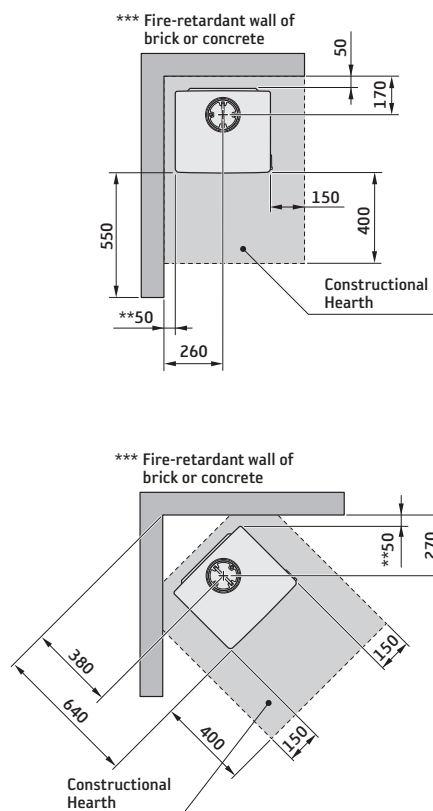

** To prevent discolouration of painted non-flammable walls we recommend that the same side distance as to combustible walls is used.

*** Example of an approved material are solid bricks or 100 mm aerated concrete.

Declaration of performance according to Regulation (EU) 305/2011

No. C110-CPR-231201

Contura

PRODUCT

Type Wood burning stove
Trade name Contura 110
Intended area of use Heating of rooms in residential buildings
Fuel Wood

MANUFACTURER

Name NIBE AB / Contura
Address Box 134, Skulptörvägen 10
SE-285 23 Markaryd, Sweden

VERIFICATION

According to AVCP System 3
European standard EN 13240:2001 / A2:2004 / AC:2007
Test institute DTI-Danish Tek, NB 1235

DECLARED PERFORMANCE

ESSENTIAL CHARACTERISTICS	PERFORMANCE	HARMONISED TECHNICAL SPECIFICATION
Fire safety	Pass	EN 13240:2001 / A2:2004 / AC:2007
Fire classification	A1	
Minimum distance to flammable materials	Rear: 150 mm Side: 350 mm Ceiling: 1875 mm Front: 1100 mm Floor: 0 / 175 mm Corner: 200 mm	
Fire hazard due to burning fuel falling out	Pass	
Cleanability	Pass	
Emissions from combustion	CO: 1500 mg/m ³ NOx: 200 mg/m ³ OGC: 120 mg/m ³ PM: 40 mg/m ³	
Surface temperatures	Pass	
Temperature on the handle	Pass	
Mechanical resistance	Pass	
Temperature in the space for wood storage	Pass	
Nominal output	5,0 kW	
Efficiency	79%	
Flue gas temperature at nominal output	281°C	
Flue gas temperature in flue spigot	NPD	

The undersigned is responsible for the manufacture and conformity with the declared performance.

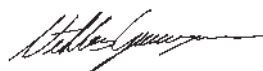

Niklas Gunnarsson, Business area manager NIBE STOVES
Markaryd, December 1, 2023



EU Declaration of Conformity

Manufacturer	NIBE AB / Contura
Address	Box 134, Skulptörvägen 10 285 23 Markaryd, Sweden
E-Mail	info@contura.se
Website	www.contura.eu
Telephone	+46 433 275100

Contura

THIS DECLARATION OF CONFORMITY IS ISSUED UNDER OUR SOLE RESPONSIBILITY FOR THE FOLLOWING PRODUCT:							
Trade name	Contura 110						
Identification of product	www.contura.eu						
THE OBJECT OF THE DECLARATION DESCRIBED ABOVE IS IN CONFORMITY WITH -							
THE RELEVANT UNION HARMONIZATION LEGISLATION:				THE RELEVANT HARMONIZED STANDARDS:			
DIR 2009/125/EC				EN 13240:2001/A2:2004/AC:2007			
REG (EU) 2015/1185				CEN/TS 15883:2010			
REG (EU) 2015/1186							
REG (EU) 2017/1369							
REG (EU) 305/2011							
TECHNICAL DOCUMENTATION							
Energy efficiency class:	A						
Direct heat output:	5,0 kW						
Indirect heating functionality:	No						
Energy Efficiency Index (EEI):	104,6						
Test report	DTI-Danish Tek, NB 1235						
FUEL	PREFERRED FUEL	OTHER SUITABLE FUEL	η_s (%)	EMISSIONS AT NOMINAL HEAT OUTPUT			
				PM	OGC	CO	NO _x
mg/ Nm ³ (13% O ₂)							
Wood logs with moisture content 25%	Yes	No	69	40	120	1500	200
Compressed wood with moisture content <12%	No	Yes	69	40	120	1500	200
Other woody biomass	No	No					
Non-wood biomass	No	No					
Anthracite and dry steam coal	No	No					
Hard coke	No	No					
Low temperature coke	No	No					
Bituminous coal	No	No					
Lignite briquettes	No	No					
Peat briquettes	No	No					
Blended fossil fuel briquettes	No	No					
Other fossil fuel	No	No					
Blended biomass and fossil fuel briquettes	No	No					
Other blend of biomass and solid fuel	No	No					
CHARACTERISTICS WHEN OPERATING WITH THE PREFERRED FUEL							
ITEM	SYMBOL	VALUE	UNIT	ITEM	SYMBOL	VALUE	UNIT
HEAT OUTPUT				USEFUL EFFICIENCY, BASED ON NET CALORIFIC VALUE (NCV)			
Nominal heat output:	P_{nom}	5,0	kW	Useful efficiency at nominal heat output	$\eta_{th,nom}$	79	%
AUXILIARY ELECTRICITY CONSUMPTION				TYPE OF HEAT OUTPUT/ROOM TEMPERATURE CONTROL			
At nominal heat output	$e_{l,max}$	-	kW	Single stage heat output, no room temperature control			Yes
At minimum heat output	$e_{l,min}$	-	kW	Two or more manual stages, no room temperature control			No
In standby mode	$e_{l,SB}$	-	kW	With mechanic thermostat room temperature control			No
				With electronic room temperature control			No
				With electronic room temperature control plus day timer			No
				With electronic room temperature control plus week timer			No
				OTHER CONTROL OPTIONS			
				Room temperature control, with presence detection			No
				Room temperature control, with open window detection			No
				With distance control option			
Specific precautions for assembly, installation, or maintenance.		Fire protection and safety distances to combustible building materials must be observed under all circumstances. A sufficient supply of combustion air must always be guaranteed. Air suction systems can interfere with the combustion air supply.					

The undersigned is responsible for the manufacture and conformity with the declared performance.

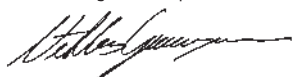

Niklas Gunnarsson, Business area manager NIBE STOVES
Markaryd, December 1, 2023



Prior to installation

If the stove needs to be laid down for it to be moved, loose components should be removed. A description of how to remove hearth cladding can be found at the end of these instructions.

- 1 Fire bricks (Vermiculite)
- 2 Type plate
- 3 Inner bottom panel
- 4 Serial number

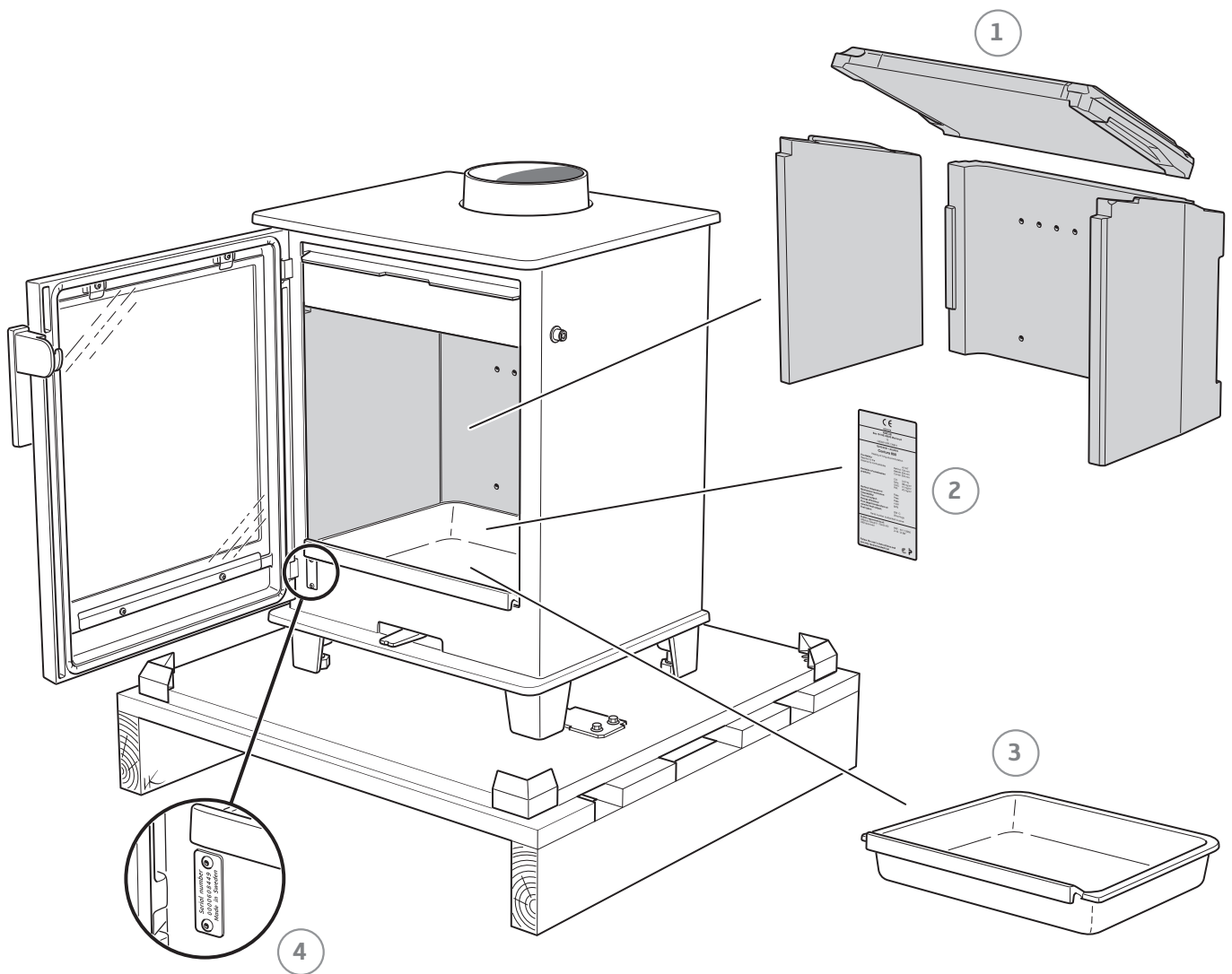

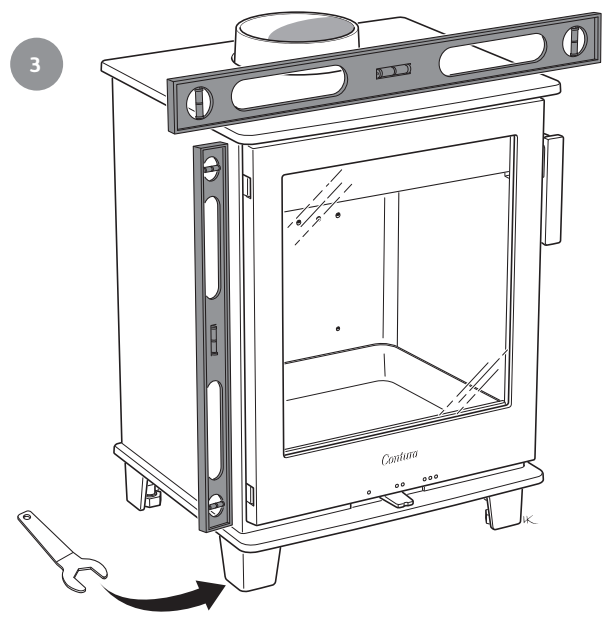
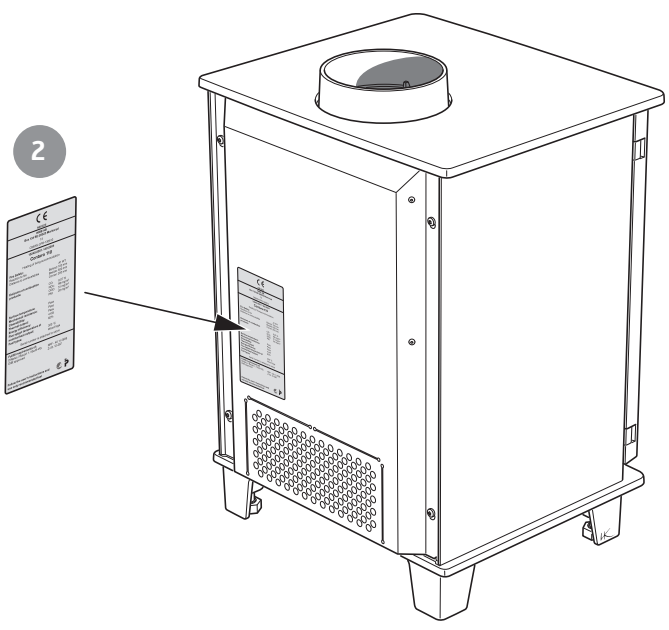
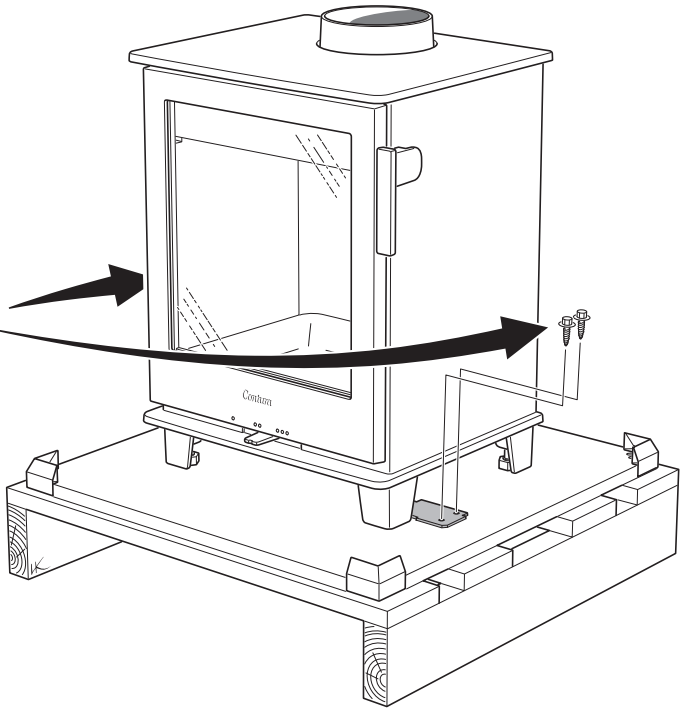
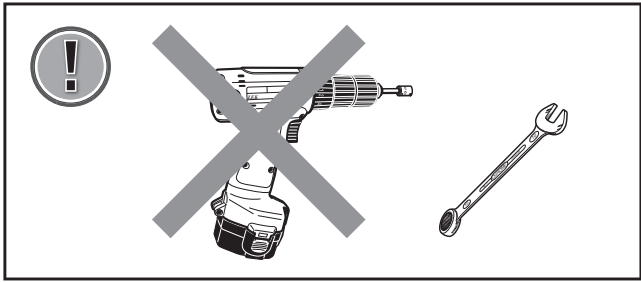



Supply (Accessory)

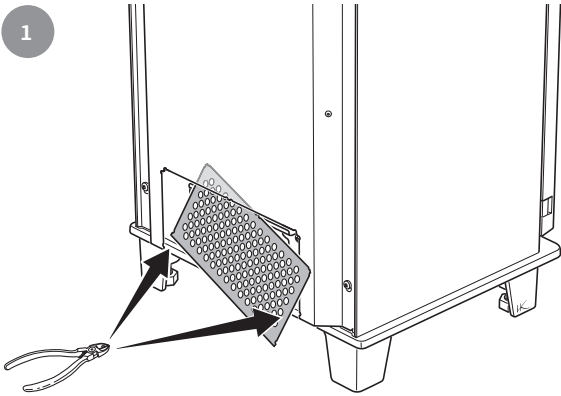

2

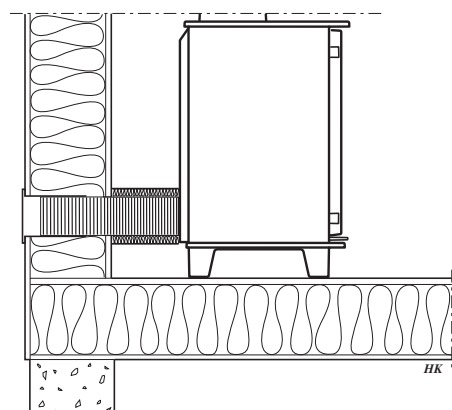
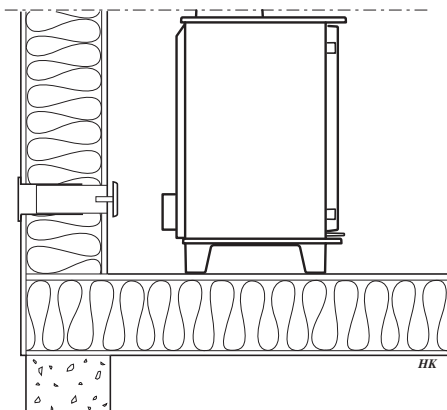
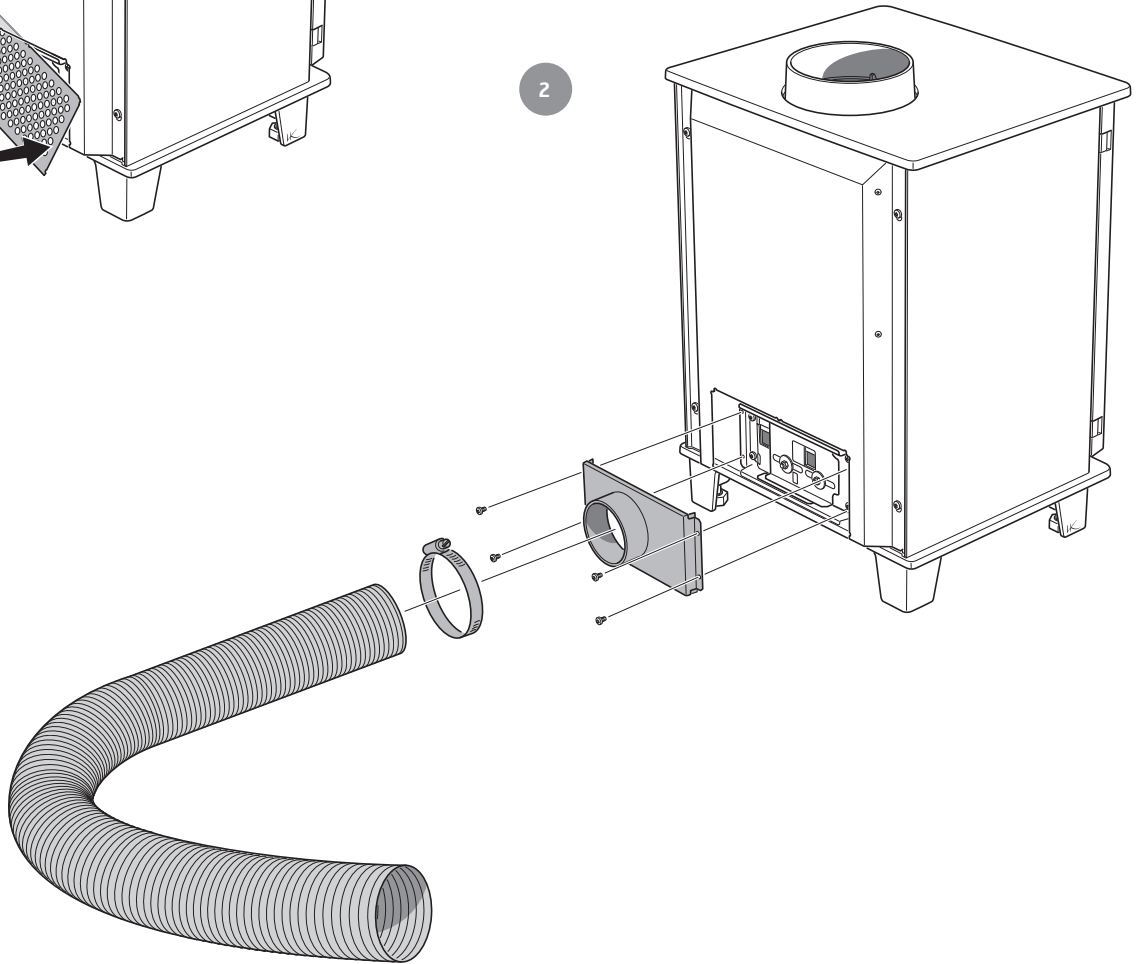



How to remove the hearth surround (Vermiculite)

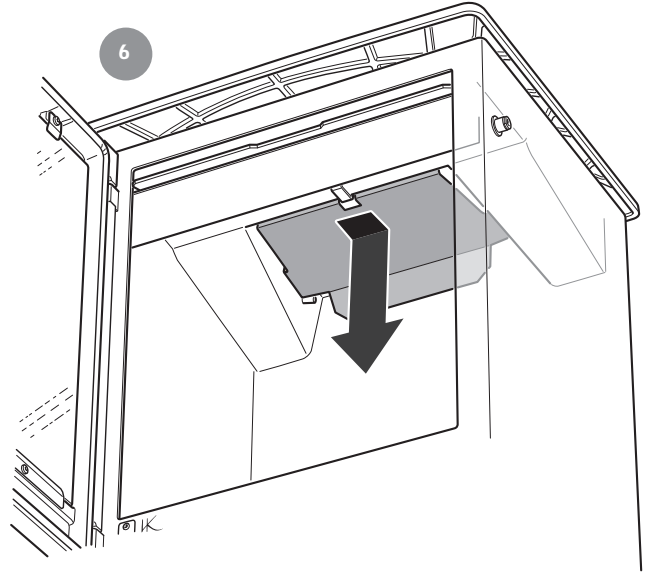
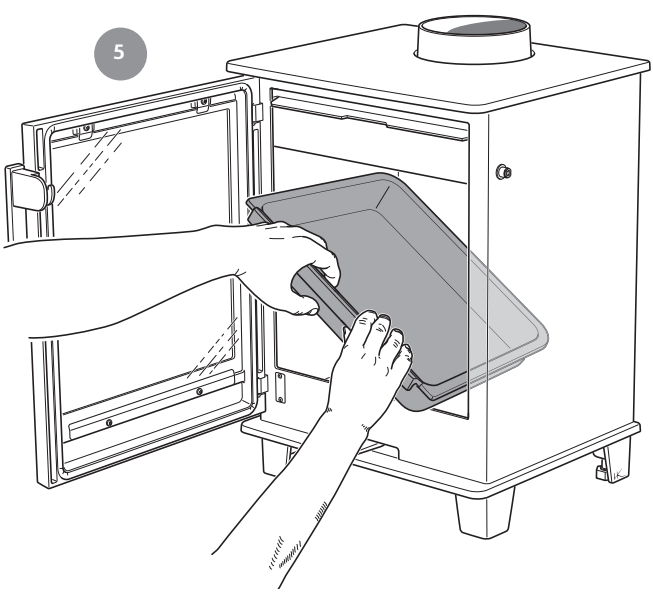
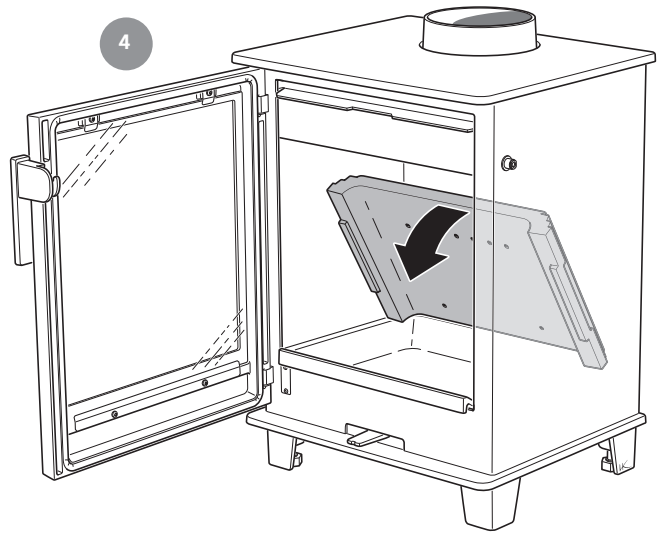
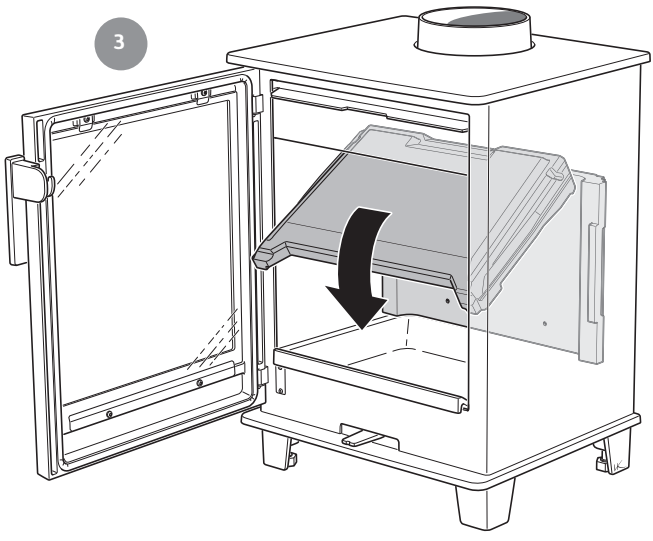
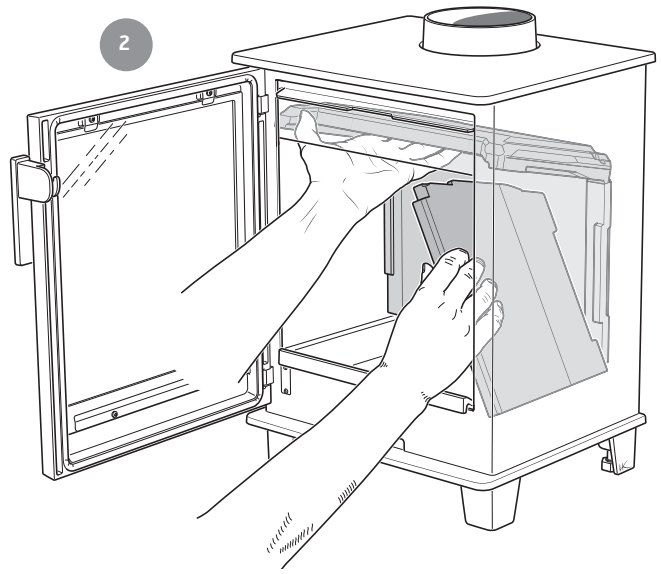
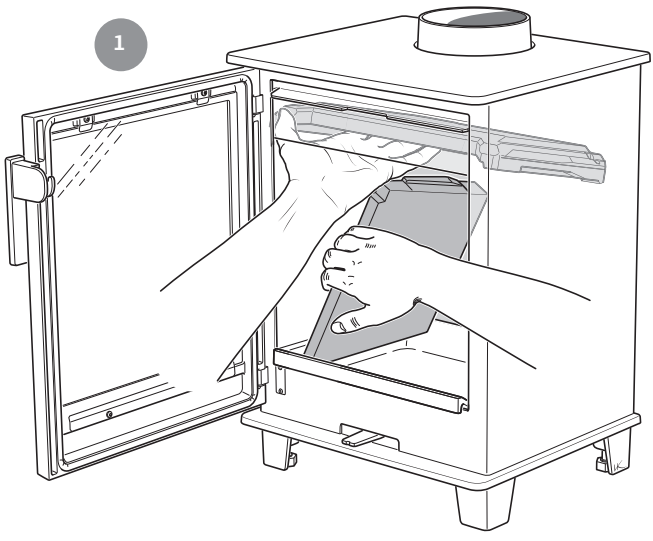



For installation in the UK and in smoke control areas

Mandatory for smoke control areas

Contura 110, 5 kW woodburning stoves has been recommended as suitable for use in smoke control areas. This when burning wood logs and operated in accordance with these instructions and when fitted with a permanent stop to prevent closure of the air control unit beyond 31% open position.

Note: When refueling - open the air control fully for 3-5 minutes before closing down to the minimum air setting.

The permanent stop must be installed if the appliance is to be used in a smoke control area, this stop must not be removed in smoke control areas, otherwise an offence will be committed if the appliance is used without the permanent stop in place.

