

THE PENMAN
COLLECTION
FIRES & FIREPLACES



INSTALLATION INSTRUCTIONS

KASSEL

WOOD BURNING STOVE

CONTENTS

1.0 USER INSTRUCTIONS	Page 4
1.1 Welcome	
1.2 Fire Plus system	
1.3 Product drawing	
1.4 Cross section drawing	
1.5 Health and safety	
2.0 INSTALATION	Page 7
2.1 Installation guide	
2.2 Installation preparation	
2.3 Ventilation	
2.4 Distance to combustibles and heat sensitive materials	
2.5 Connecting to the chimney	
3.0 OPERATING INSTRUCTIONS	Page 10
3.1 Suitable fuels	
3.2 The Clean Air Act 1993 and smoke control areas	
3.3 After use and maintaining the perfect burn	
3.4 Continued use and care	
3.5 Cleaning	
4.0 TROUBLESHOOTING	Page 14
4.1 General troubleshooting	
COMMISSIONING CHECK LIST	Page 15

1.0 USER INSTRUCTIONS

1.1 Welcome

A very warm welcome from Percy Doughty, and thank you for purchasing the Olsberg Kassel wood burning stove from the Penman Collection. The stove is one of our finest and we hope you enjoy years of pleasure once your new stove is installed.

Percy Doughty prides itself in providing the very best products ensuring a timeless design with longevity of service. Our stoves will enhance your home and become a real focal point of beauty and elegance.

The stove has been designed in such a way as to perform to the optimum combustion which is both environmentally friendly and efficient, with the best possible design in mind the heat produced will provide you with all the comfort and control needed.

By reading these instructions it will give you the best insight in to using your stove efficiently and ultimately to prolong its life's service to your family. This instruction manual will also help you when lighting your stove and through its general use and care.

Percy Doughty always recommends that the stove is installed by a HETAS registered engineer and serviced on an annual basis but not limited to. The stove is a quality precision engineered product, if the installation has been incorrect or the appliance gets mistreated by overloading or using the incorrect fuel, it can damage the appliance and connecting flue system.

1.2 Fire Plus System

The Fire Plus System of your OLSBERG stove provides optimal, environmentally friendly burning and – combined with an effective heat exchange system – high efficiency.

After loading and lighting the fuel, the first phase of the combustion process starts by proceeding to burn the gases leaving the fuel. This is the time of, "high flames". After the flames reduce, the rest of the coal burns up in the second phase of the combustion process. This process is characterized by strongly glowing embers with no or only smaller, temporary flames.

Optimal and environmental friendly burning with high efficiency can only be achieved if we provide the necessary quantity of air at the appropriate places in all phases of the combustion process. Both the longer time spent in the combustion chamber by gases mixed with air and the hot combustion chamber have a positive effect on the combustion process.

This effective burning can be achieved by the Fire Plus System. The primary air flow through the openings of the grate is completed by the secondary air flow through the glass front and tertiary air entering at different heights of the combustion chamber. Wood, wooden briquettes and brown coal briquettes are fuels of "high flame".

At this height and later above the glowing embers secondary and tertiary air get inside in such way that mixing of the air and gases and the time that gases spend in the combustion chamber (depending on their structure) results in good burning. The excellent quality lining (chamotte, vermiculite) of the combustion chamber provides high temperature, helping the process.

After, that gases are lead through one or more dead-plates in the upper part of the stove, namely through a heat exchange system, that consist of a pipe system where heat is transmitted again.

Gases finally leave the stove through the flue outlet and then enter the chimney at a temperature of 250 – 330 °C through the connecting pipe. The remaining energy content of the gases provides the necessary feed pressure in the chimney, "motor of the stove". This is the operating principle of OLSBERG stoves.

Overloading:

Fireplaces are structurally not suitable for non-stop use. Only a relatively small amount of fuel must be loaded in the combustion chamber at any one time. More information about quantities of fuels to be used is given in technical data.

1.0 USER INSTRUCTIONS

1.3 Product drawing

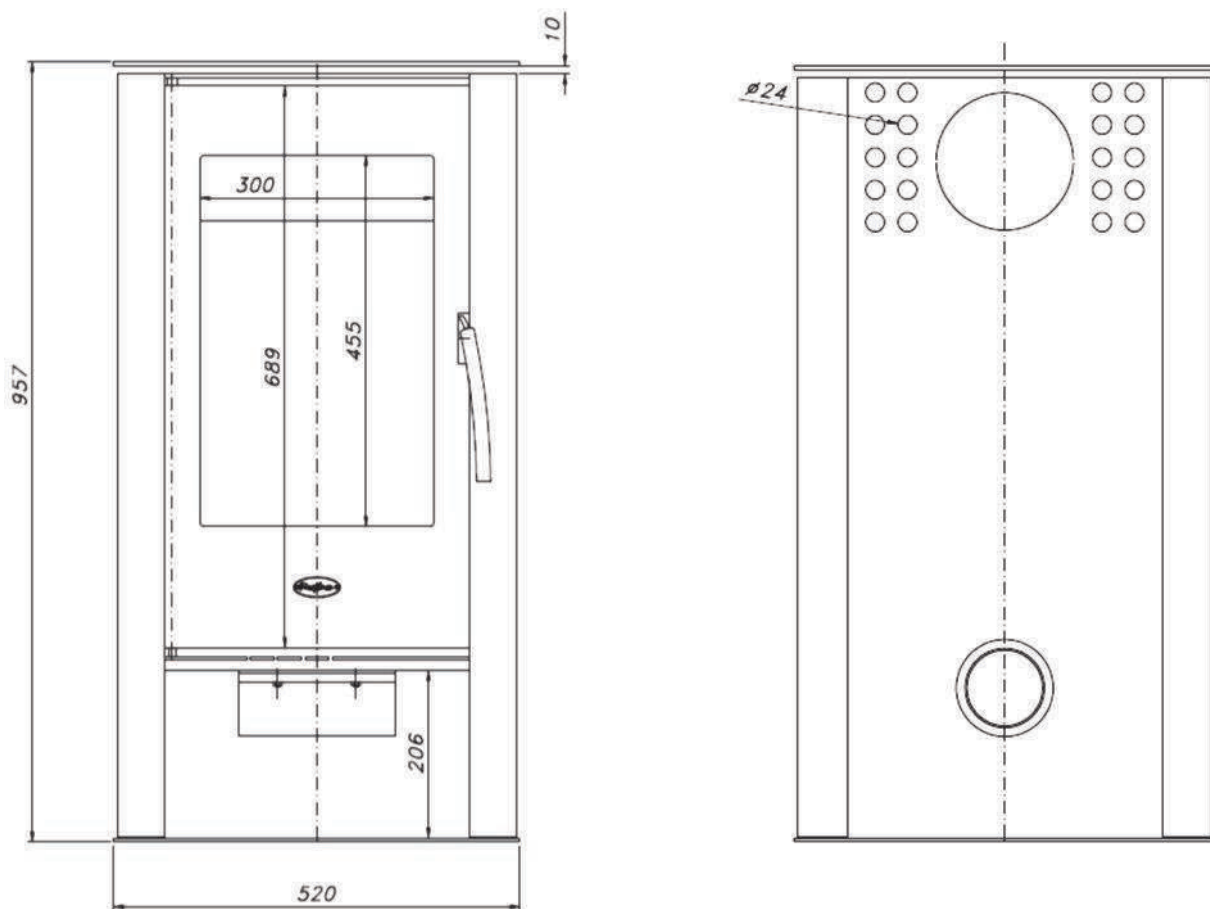

1.4 Cross section drawing

- 1 Primary air
- 2 Secondary air
- 3 "Cold" air of room
- 4 Warm air
- 5 Escaping gases
- 6 Hot gases
- 7 Grate
- 8 Chamotte or vermiculite lining
- 9/10 Tertiary air
- 11 Charcoal pan

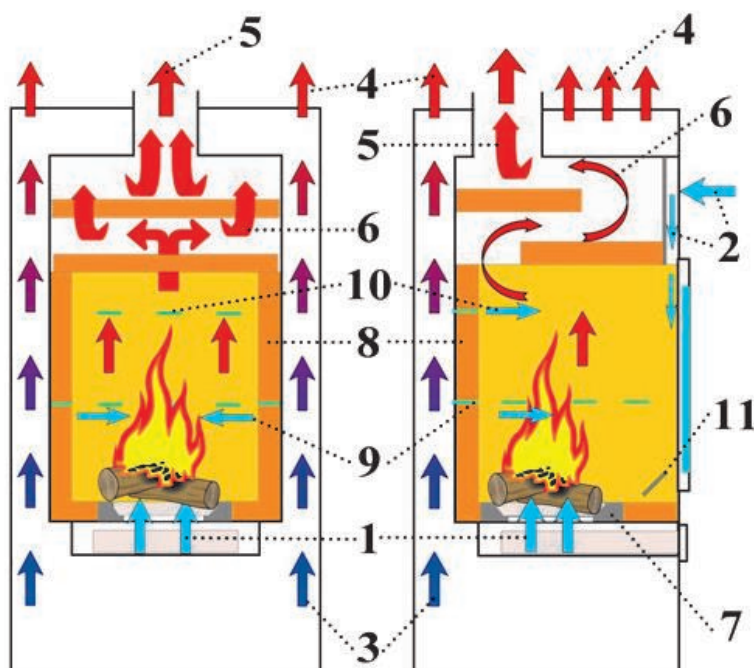

1.0 USER INSTRUCTIONS

1.5 Health and safety

The necessary feed pressure for chimney examination given on the technical data sheet is the necessary minimum value at the flue outlet of the stove. This is necessary for safe operation of the stove. Practice shows that higher, sometimes too high, feed pressure exists in chimneys. Such high feed pressure (more than 20 Pa) can lead to uncontrollable combustion process that can damage the appliance itself, the connecting flue pipe and the chimney system as a whole. Contact a registered HETAS engineer or a competent person about finding a solution in such cases, we recommend the use of a feed pressure regulator (flow control valve in the flue or providing secondary air inside the chimney).

Olsberg stoves comply with DIN 18891 (building category 1) and DIN EN 13240 standards.

Olsberg stoves are freestanding stoves that cannot be equipped with an individual cover or be built in as a fire chamber insert/cassette. You must not make any modifications influencing the operation of the stove.

Remove all packaging and supporting materials from the chamber and all accessories from the ash drawer and the wood case. Make sure that the lining of the fire chamber and all pieces of the dead plates are in the correct place and fitted correctly. Do not use the stove without these components. Take care as the packaging material can contain nails and other sharp pieces of metal, which can cause injury to you and the stove. Take care that the nylon and other wrapping materials do not get in children's hands, as they can cause suffocation. Carefully collect the packaging materials mentioned above, and take them to the local waste disposal site.

The stove is painted in high temperature paint and high quality heat resistant lacquer that gains its final stability when heating up for the first time. The smell at the first heating up derives from the evaporation of the protection lacquer in the paint. So the heated room must be carefully ventilated from time to time (every 1-2 hours). The smell will stop after a while of burning.

Do not put anything on the stove before the first heating up and do not touch its surface to prevent damage of lacquering. Use protective gloves for your own protection and for the sake of the intactness of the lacquering.

The doors of the stove should be kept slightly open during the first heating up so the insulation cord does not stick to the front of the stove.

Caution

Surfaces are hot. When you operate the appliance wear gloves and use the operating handles of the stove. The glass is hot. Keep children away.

Never use spirits, petrol or any other flammable and explosive substance for lighting the fire.

Don't place combustible objects inside the radiation area of the fireplace, within 100 cm from the door of the combustion chamber.

2.0 INSTALLATION

2.1 Installation guide

In the absence of pertinent installation information, the British standards and current building regulations must be followed to ensure compliance and safety.

This appliance must be installed by a HETAS registered engineer and the installation must be in accordance with the British standards and current building regulations. Please see below for guidance but not limited to and the statutory requirements.

- BS 8303
- BS EN 15287 1
- BS EN 15316
- BS EN 1856 – 1 2009
- BS EN 1856 – 2 2009
- Approved Doc J
- Health and Safety at Work Act
- The Provision and Use of Work Equipment regulations
- Personal Protective Equipment at Work regulations
- Construction Design and Management regulations
- Control of Asbestos
- Working at Height regulations
- Manual Handling regulations

The stove may be installed in to a location where additional fire protection measures need to be taken into consideration. A risk assessment must be completed by the registered HETAS installation engineer or the principal designer for purposes of the current Construction Design & Management Regulations.

Please see the technical data below for clearances to combustible materials, this will allow for a comprehensive risk assessment to be completed.

Material	Cast iron/steel
Ventilation requirements Surface	In accordance with British Standards
Surface door rope size	12mm
Output	5kW
Overall dimensions mm (HxWxD)	957 x 520 x 413
Weight	98kg
Draught pressure max	20pa
Draught pressure min	12pa
Tertiary air	Yes
Combustion System	Primary/secondary
Heating area	90m ³
Flue outlet options	Top and rear
Flue collar size	125mm
Average temp at flue collar	348°C

Distance from bottom of stove to centre of rear flue outlet	839mm
Diameter of external flue spigot	100mm
Distance from bottom of stove to centre of direct air connection	190mm
Log size	250mm
Fuel weight	1.3kg
Moisture content	16%-20%
Distance to combustibles (side)	300mm
Distance to combustibles (rear)	200mm
Distance to combustibles (front)	500mm
Safety distance to combustibles materials (furniture)	100mm
Adequate distance left for maintenance (rear and sides)	150mm

2.0 INSTALLATION

2.2 Installation preparation

Consideration must be taken in relation to the appliance location and safe flue route in the first instance in accordance with the appliance instructions and technical data. The chimney must be suitable for operating the appliance safely and all selected components must be compliant in accordance to the relevant British standards.

The appliance and flue system must be installed by a HETAS registered engineer and pertinent commissioning documents and evidenced system checks of the installation in its entirety must be left with the end user.

Location

Choose a location for the appliance close to the chimney to prevent the use of a long horizontal connecting pipe. All horizontal rear connections must not be more than 150mm.

The location of appliance must be flat and level. The floor must also have the necessary load bearing capacity. The weight of the appliance can be found on the attached technical data. In case the load-bearing capacity of the floor is too low, usage of a plate for better load distribution might help, but a structural engineer must advise if in any doubt.

Fixing Ceramic Glass or Soapstone Lid

Before connecting the stove, please take off all accessories that are not attached, such as top soapstone/ceramic tile or the soapstone /ceramic tiles placed in the warming plate. This way you can prevent these parts from falling while moving the stove. Do not attempt to maneuver the stove in to position or work on the flue with the soapstone or ceramic top in place as it may become damaged. For further information to retrofit any soap stone covers then the manufacturer must be contacted in the first instance.

2.3 Ventilation

Ventilation must be provided in accordance with Approved Document J .If the appliance is to be installed in to a room which is completely airtight, a separate external air inlet pipe is needed to guarantee a sufficient supply of air for the safe operation of the appliance. The appliance may have an optional connection for the use of an external direct air supply and for guidance on installation, please see the Percy Doughty Technical Bulletin #002.

2.4 Distance to combustibles or heat sensitive materials

The technical data Fig 2.1 shows the distances to combustible and heat sensitive materials.

In case of combustible floors, being sensitive to a rise in temperature, non-combustible floor protector must be used. This floor protector must reach 500mm beyond the front (from the charcoal pan), 300mm beyond the side (from the inner wall of the combustion chamber) of the appliance. The material of the floor protector can be made of metal or glass.

The given minimum safety distances from combustible or heat sensitive materials must be adhered to at all times and not compromised, this will include all areas of the appliance front, rear & sides.

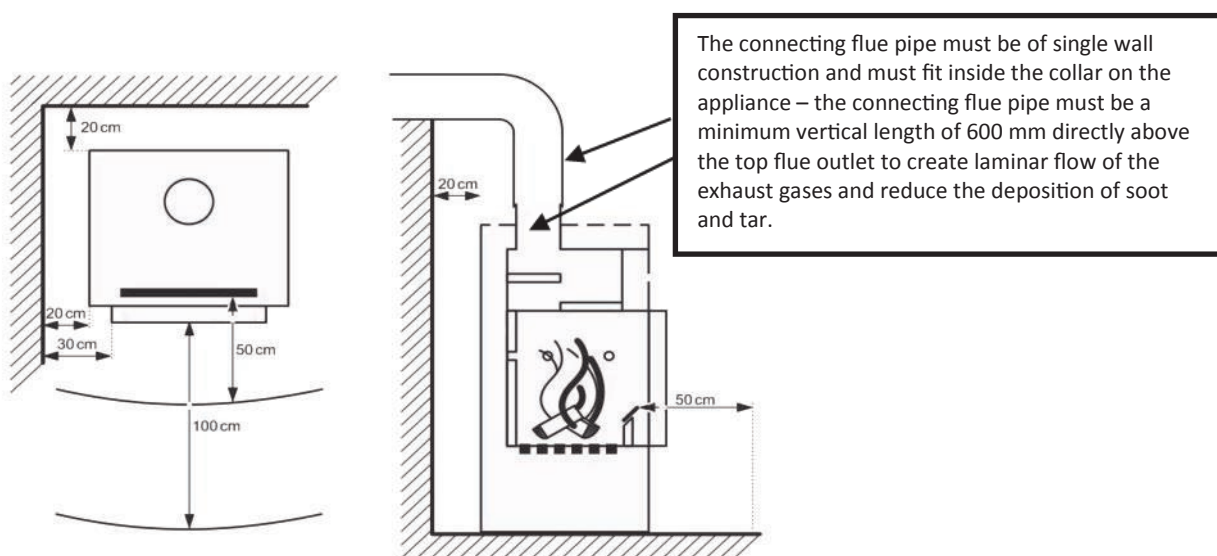

2.0 INSTALLATION

2.5 Connecting to the chimney (including the connecting flue pipe)

Diameter of flue outlet is 125mm

The appliance is equipped with a top and rear outlet. We recommend the top outlet is used for best performance because of combustion technological reasons. However the stove can also be connected from the rear (technical data contains the connection height), remove the flue outlet from the top of the appliance and the blanking plate from the back. Connect the flue outlet collar on to the rear ensuring the top outlet is sealed using the blanking plate. Check all outlets for spillage when operating the appliance. The heat plate must be used to protect the rear outlet if not in use.

Top connection:

The minimum length of the connecting flue pipe must be 600mm and **it must** be inserted into the collar. It **must not** sleeve over the collar and rest on the covers as referenced below

- Soapstone Top
- Ceramic/Glass Top

The connecting flue pipe must be in accordance with BS EN 15287-1. Twin wall connecting flue pipe is not permitted and appliance adaptors are not recommended and must be approved by the manufacturer prior to use.

Please refer to Percy Doughty Technical Bulletin #001 for further guidance

Connecting to the chimney:

Single-skin connecting flue pipes shall not be used as a complete chimney; they shall only be used to connect an appliance to a suitable chimney or twin wall system chimney. We recommend the use of a connecting twin wall adaptor for connecting to the chimney. The insert has to be fully installed into the chimney in order to prevent movement during normal use which could cause joint separation and leakage to occur between the appliance and the flue such as to impair the ability of the chimney to evacuate products of combustion safely to the outside atmosphere. All connections must be exact and insulated. All combustible materials have to be removed within a 200mm radius of the insert and have to be replaced by heat resistant/non-combustible material.

If there is wallpaper in the direct vicinity, it must be removed from behind the stove and from the side.

Fixing Ceramic Glass or Soap stone Lid

Before connecting the stove, please take off all accessories that are not attached, such as top soapstone/ceramic tile or the soapstone /ceramic tiles placed in the warming plate. This way you can prevent these parts from falling while moving the stove. Do not attempt to maneuver the stove in to position or work on the flue with the soapstone or ceramic top in place as it may become damaged. For further information to retrofit any soap stone covers then the manufacturer must be contacted in the first instance. Follow the directions below when you light the fire for the first time.

3.0 OPERATING INSTRUCTIONS

3.1 Suitable fuels

Please note that HETAS Ltd Appliance Approval only covers the use of wood logs and approved smokeless fuels on this appliance. HETAS Ltd. Approval does not cover the use of other fuels either alone or mixed with the recommended fuels listed above, nor does it cover instructions for the use of other fuels.

Use the following fuels only:

- Dry wooden log (beech, oak)
- Wooden briquette
- Brown coal briquette

You can find the exact information on the technical data and on the appliance data badge. You must only burn the specified fuel and failure to burn the correct fuel can damage the appliance and chimney system. This would also invalidate the warranty of the appliance.

Depending on your choice of the fuels listed above, be sure that you use fuels of good quality.

Wooden logs reach 15-20% humidity which is the most appropriate for heating if they are stored outside for 1 to 2 years (if they are covered and protected from rain). Recently cut wood has a high moisture content and burns poorly and causes soot. Apart from its very low heating value it is also a pollutant to the environment. High condensation and tar can lead to blockage in the stove and especially in the chimney. In all cases it causes deposit on the glass front and emissions that need to be avoided.

Burning wood is recommended for operating the appliance at its nominal capacity. You can get the exact data at a fuel supplier. Load the fireplace with fuel according to heat demand. The heating value of 1 kg of dry wood is 4 – 4.5 kW/h. So you can place about 1.3 kg of wood into a stove of 5 kW capacity every hour.

When burning wood, if you would like to reach a lower capacity, do not restrain the fire. Put less wood in at one time instead.

Don't throw the fuel in the combustion chamber, because it can damage or break the chamotte or vermiculite tiles. Be aware that the volume of some types of wooden briquettes increases during burning. Choose the wooden briquette that has the appropriate size to the measurements of the combustion chamber and does not increase in size while burning.

You can use brown coal briquette for burning at nominal capacity just as wood or wooden briquette. Apart from that, it is also excellent for keeping the embers glowing during the night (about 10 hours). In the case of brown coal briquettes, wait until the fuel is completely burned through and close the primary air regulator to keep the embers burning only after that. The types of fuels that can be used, the maximum quantities that can be loaded at one time and the description of settings for the air regulators, can be found in the attached technical chart.

Reducing emissions

You can only avoid unwanted emissions by the use of the specified fuels. Put only the amount of fuel in the fireplace that is appropriate for necessary heat transmission. Burning more fuel is unnecessary and leads to unwanted emissions. Don't burn waste in the appliance or products that can dramatically pollute the environment. This will also damage the appliance. The use of other fuels than the ones listed above is not allowed.

You **MUST NOT** burn the following materials in the fireplace:

- Wet or treated wood,
- Wood-shavings, sawdust,
- Inner bark, bark, shavings panel,
- Coal dust,
- Waste, scrap, plastic, rubble
- Paper and cardboard (apart from lighting the fire)

3.0 OPERATING INSTRUCTIONS

3.2 The Clean Air Act 1993 and smoke control areas

Under the Clean Air Act local authorities may declare the whole or part of the district of the authority to be a smoke control area. It is an offence to emit smoke from a chimney of a building, from a furnace or from any fixed boiler if located in a designated smoke control area. It is also an offence to acquire an “unauthorised fuel” for use within a smoke control area unless it is used in an “exempt” appliance (“exempted” from the controls which generally apply in the smoke control area).

In England appliances are exempted by publication on a list by the Secretary of State in accordance with changes made to sections 20 and 21 of the Clean Air Act 1993 by section 15 of the Deregulation Act 2015. Similarly, in Scotland appliances are exempted by publication on a list by Scottish Ministers under section 50 of the Regulatory Reform (Scotland) Act 2014. In Northern Ireland appliances are exempted by publication on a list by the Department of Agriculture, Environment and Rural Affairs under Section 16 of the Environmental Better regulation Act (Northern Ireland) 2016. In Wales appliances are exempted by regulations made by Welsh Ministers.

The Firefox 8 Eco and Classic 8 Eco have been recommended as suitable for use in smoke control areas when burning dry wood and the “authorised” smoke free solid fuels.

The “authorised” solid fuels you are permitted to burn in a smoke control zone include: anthracite (this is naturally occurring smokeless fuel and is the test fuel normally used and recommended), Ecoal 50, Homefire, Homefire ovals, Phurnacite, Taybrite and Multiheat.

3.3 After use and maintaining the perfect burn

Follow the directions below when you light the stove for the first time.

A high burning temperature is necessary for the fuel to catch fire quickly so put enough fire-starter on the grate at the lower part of the combustion chamber. Put 2 or 3 smaller pieces of wood or a similar quantity of wooden briquettes, or 3 to 4 pieces of brown coal briquettes on the grate (see picture A)

After lighting the fire, shut the door leaving it ajar. Only leave the door ajar when you light the fire for the first time (after the first time you will shut the door completely) and fully open all air regulators. After the wood or briquettes have caught fire you can adjust the amount of air flowing into the stove to suit your preference.

After a layer of glowing embers has been formed and you can no longer see any flames, you can place more fuel into the stove and set the desired output with the aid of the air regulators (see picture B, C1 and C2)

Always maintain optimal burning. If you use too much fuel or let too much air flow into the combustion chamber, you may overload the appliance. **Important note:** this leads to high temperature and emissions which should be avoided.

The appliance is painted with a high quality heat resistant lacquer that gains its final stability during the first heating. The smell produced from the first heating derives from the evaporation of the protecting lacquer in the paint and is completely normal. The room must be ventilated from time to time to allow the smell to disperse (every 1-2 hours).

Do not put anything on the stove before the first use and do not touch its surfaces as it will cause damage to the lacquering. Use protective gloves for your own protection and the integrity of the lacquer.

The door of the stove should be kept slightly ajar during first use to prevent the insulation cord from sticking to the front of the appliance.

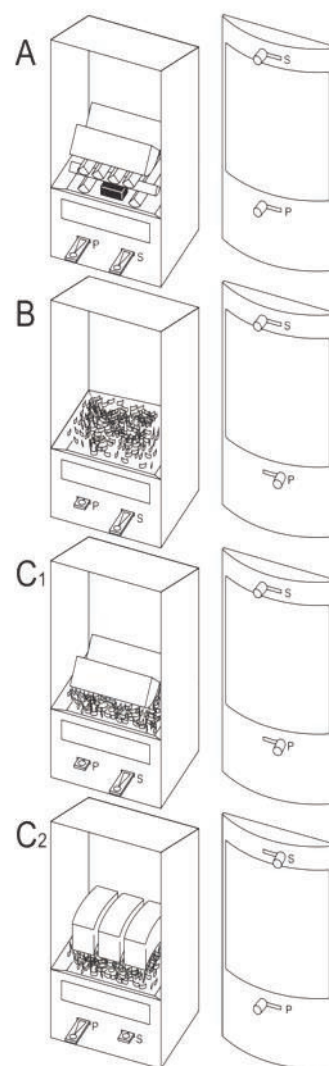

3.0 OPERATING INSTRUCTIONS

3.4 Continued use and care

Always empty the ash drawer before each use, while the unit and the ashes are cold, because a full ash drawer can:

- Obstruct air supply
- Damage the grate

Always store the ash in a fire-proof container. Do not put the container close to combustible materials or place it on a combustible surface. Use a protective plate if necessary. Pour the ash into a waste receptacle only after you make sure that it has completely cooled down. After emptying the ash drawer, replace it immediately.

Continue the lighting procedure according to the section 3.3 "After use and maintaining the perfect burn".

Load more fuel only if the current fuel is only glowing and flames are not visible any more. When loading more fuel, open the door of the combustion chamber slowly so that the smoke gases cannot flow out through the door. Level the glowing embers. Put the amount of fuel necessary for the desired heating capacity on the embers, leaving an inch of space between each piece. Close the door immediately after loading the fuel and keep it closed during use.

Set the air regulators according to the nominal capacity, or in case of brown coal briquettes as desired after it has burned down to embers. Repeat the procedure after the fuel has burned down and always maintain optimal burning.

- Never put more fuel in the stove at one time than is specified. (See technical data on page 6)
- Only one portion of fuel can be burned at the same time. Load more fuel only after the fuel in the unit already has burned down.
- Always check that there are not too many glowing embers piling up in the combustion chamber.
- Do not restrain the fire, load less fuel instead, and never close the primary air regulator completely.
- Your stove is equipped with an automatically closing door. It can be operated only with a closed door.
- Open the door only if you want to load more fuel and only if the previous amount has burned down to embers.
- Remember that the appliance can become extremely hot when in operation therefore it is important to ensure children and vulnerable persons are aware of the risk at all times .

Maintain the settings of the air that is necessary for the burning capacity of the stove and keep in mind that the settings of the air depend considerably on the actual chimney draught. You can set the controls to achieve your own personal heat preference. Not using the air settings correctly can lead to blackening of the glass front or damage to the appliance and chimney system.

The lining of the combustion chamber (chamotte or vermiculite) can turn black when you light the fire. This blackening disappears when the stove reaches its operating temperature.

The condition of proper operation of the fireplace is the appropriate chimney draught (Flow pressure). This is considerably dependent on the temperature of the outer environment. In case of a higher outer temperature (above 15°C) flow pressure can considerably fall and if the appliance is used in these conditions then its performance may be impeded.

Important Note: The appliance chimney system can catch fire through neglect , therefore regular maintenance is essential and periods will differ dependent on usage. In the event of a suspected chimney fire, call the emergency services immediately and close down all air regulators if practical to do so without the risk of injury or harm. Do not pour water onto the fire as this could lead to an explosion, do not attempt to tackle the fire, evacuate the property and wait for the emergency services to attend.

3.0 OPERATING INSTRUCTIONS

3.5 Cleaning (to be performed only when stove is cold)

What	Frequency	Utensil
Combustion chamber of stove	Min. once a year but not limited to	Hand broom Vacuum cleaner
Smoke outlet	Min. once a year but not limited to	Hand broom Vacuum cleaner
Copper elements	As necessary	Copper cleaning agent or other substance with Teflon content (when it is cold)
Glass	As necessary	With stove glass spray or glass cleaning agent (when it is cold) Do not use anything abrasive that may scratch the glass.

4.0 TROUBLE SHOOTING

4.1 General troubleshooting

Weather conditions may affect the performance of the appliance and temperatures above 15C may impede the flow pressure of the appliance.

What can you do?

1. Open the primary air regulator a bit more, and fully open the secondary air regulator.
2. Use only a small amount of fuel at first.
3. Use only a small amount of fuel when reloading.
4. Shake off the ash more often.
5. Do not restrain the fire.
6. Burn through the brown coal briquettes very well and close the primary air regulator for keeping embers glowing only after that.
7. As a last resort, do not use the stove in a transition period.

What are the causes?

1. There is no proper draught at heating up, potentially caused by either:
 - A: Chimney or stove pipe is not closed properly.
 - B: Measurements (Height, flue configuration) of the chimney are not appropriate
 - C: The door of the stove/supplementary air regulator or the door to another stove is connected to the same chimney is open.

The room or space is not being adequately heated up by your appliance?

1. Is the appliance disproportionately small or incorrectly sized?
2. Is there too much ash in the combustion chamber?
3. Is the liner blocked due to the use of incorrect fuel being used?
4. Is the terminal blocked?
5. Is the air regulator closed?

The appliance is giving off too much heat?

1. Is the air regulator opened too far?
2. Is the chimney draught (Flow Pressure) too high?
3. Did you load too much fuel at once?
4. Is the fuel being used the correct?

The grate is damaged or corroded, bricks have cracked?

1. The fireplace has been overloaded.
2. You didn't empty the ash drawer sufficiently during its continued use
3. Chimney draught (Flow pressure) is too high.

COMMISSIONING CHECKLIST

- Ensure the serial number has been recorded on the front of this manual for any future use**

- Ensure the door seals are in good condition and that the glass is secured correctly in the door (do not over tighten the glass as this will prohibit its expansion and could cause the glass to crack)**

- Ensure that all internal components are fitted correctly (these may have shifted in transit)**

- Ensure that the appliance operates correctly during the first firing**

- Ensure the customer is aware that fumes may be given off during the first firings as the paint cures**

- Advise the customer on the safe operation of the appliance**

- Leave the instruction manuals, operating tool and glove for the customer's use.**

- Record the flue draught reading of the appliance**



THE PENMAN
COLLECTION
F I R E S & F I R E P L A C E S

Brought to you by

 **PERCY DOUGHTY**

Imperial Point
Express Trading Estate
Stone Hill Road
Farnworth
Bolton
BL4 9TN

Tel: 01204 868 550 Fax: 01204 868 551 Email: sales@percydoughty.com

www.penmancollection.com