



## PANAMERA STOVE INSTRUCTIONS

PLEASE READ THESE INSTRUCTIONS AND USE ONLY THE RECOMMENDED FUELS



# ECO2022

REDUCING CARBON EMISSIONS IN THE UK

QUICK START GUIDE	3
<hr/>	
PERFORMANCE	4
<hr/>	
STOVE SAFETY	6
ASBESTOS	
WEIGHT	
CHIMNEY	
FIREPLACE	
AIR SUPPLY	
EXTRACTOR FANS	
STOVE CLEARANCES	
<hr/>	
FITTING	8
<hr/>	
LIVING WITH YOUR STOVE	10
LIGHTING	
FILLING	
DAMPERS	
CONTROL	
EMPTYING ASHES	
EXTENDED BURNING	
CLEAN WINDOWS	
DOOR	
SUMMER SHUT DOWN	
FUELS	
SMOKE CONTROL	
WOOD	
JOINERY WASTE	
PEAT	
LIGNITE	
ANTHRACITE	
COKE	
BRIQUETTES	
PETROLEUM COKE	
HOUSEHOLD WASTES	
<hr/>	
SPARE PARTS	13
<hr/>	
TROUBLESHOOTING	14
<hr/>	
MAINTENANCE	15

## QUICK START GUIDE

To get the most out of your stove you should take the time to read the instructions provided. If for any reason you don't have these instructions contact your retailer and request a copy. This guide is intended to help you get the best possible fire started. Even if you have previous experience with stoves, all makes and models vary and the information below will help you gain the optimum performance from your new stove.



Make sure both the primary (bottom) and secondary (top) valves are open. The open position is with both controls fully to the right.

To start a fire, create a small 'wigwam' of kindling towards the back of the grate and light it using a single firelighter.

Close the door and wait until the firelighter burns away and the kindling is fully ignited.



Open the door and use a poker to lay the kindling across the width of the grate.

It is best to keep the fuel towards the back of the grate during these early stages.

Place a small kiln dried log (less than 15% moisture) on top of the kindling and close the door.

Wet wood will cause the stove window to blacken.

Do not cover the tertiary air holes (the small holes located at the rear of the firebox above the back brick).



Once the log starts to burn close the primary (bottom) valve by sliding it to the left.

If you're continuing to burn wood use the secondary (top) valve to control the fire, we usually recommend half closing it but every installation will vary so try different settings until you find one you're happy with. If you're burning solid fuel, such as anthracite, wait until you have a bed of hot ash and then add your fuel.

The settings for solid fuel are the opposite to wood, fully close the secondary (top) valve and control the rate of burn using the primary (bottom) valve.

Don't over fill the firebox, this is a very efficient stove and will generate plenty of heat with a small amount of fuel.

## PERFORMANCE

Panamera / Vega Panamera Solid Fuel Stove Manual Version 1.1 Issued March 2018



**This document is to be left with the householder after installation.**

All our stoves exceed the safety and performance requirements of European Standards.

Independently tested by SGS (Notified Laboratory No: 0608) in 2018.

Intermittent burning solid fuel roomheaters for installation with a single dedicated chimney.

1	SUPPLIER NAME OR TRADEMARK	
2	MODEL IDENTIFIER	PANAMERA / VEGA PANAMERA
3	ENERGY CLASS	A
4	DIRECT HEAT OUTPUT	4.8KW
5	INDIRECT HEAT OUTPUT	N/A
6	ENERGY EFFICIENCY INDEX	106.3%
7	ENERGY EFFICIENCY AT NOMINAL HEAT OUTPUT	79.5%
8	SPECIFIC PRECAUTIONS	SEE MANUAL

Fuel	Wood (Beech)	Mineral Fuel (Anthracite)
Test Standard	EN13229	EN13229
Test Cycle	1.06kg over 0.68hrs	0.60kg over 1.01hrs
Settings	Primary 0, 2nd 100%	Primary 100, 2nd 10%
Flue Draft Pa (ins WG)	12 (0.05)	12 (0.05)
Efficiency %	79.5	84.8
Recommended Rating kW	4.8	4.7
Mean Flue Gas Temp Rise ° K	253	218
Minimum air entry requirement	2500mm <sup>2</sup>	2500mm <sup>2</sup>
Minimum clearance to combustibles	300mm at sides, 400mm above when fitted in masonry fireplace	
Weight	60kg	
Flue outlet size	125mm	
<b>Emissions as if O<sub>2</sub> = 13%</b>		
Nox mg/m <sup>3</sup>	114	
CO %	0.12	0.05
CxHy mg/m <sup>2</sup>	118	
Gas Flow g/sec	4.4	3.4
Smoke emission mg/m <sup>3</sup>	34	
<b>Read these instructions! Use only recommended fuels!</b>		

This stove must be installed and commissioned by a fully qualified registered engineer, or the building inspector must be informed. For more details contact your local authority. This document, when completed by the installer, constitutes part of a 'Hearth Notice' for purposes of Building Law. It must be left with the householder and placed where it can easily be found.

Installed at Location: .....

By: .....

I definitively assert that this installation is safe, has been lit and demonstrated to the householder, conforms with current building regulations and with these instructions.

Signed: .....

Date: .....

Flue Draught measured on commissioning: .....

Fuel used on commissioning:.....

### **The Clean Air Act 1993 and Smoke Control Areas**

Under the Clean Air Act local authorities may declare the whole or part of the district of the authority to be a smoke control area. It is an offence to emit smoke from a chimney of a building, from a furnace or from any fixed boiler if located in a designated smoke control area. It is also an offence to acquire an "unauthorised fuel" for use within a smoke control area unless it is used in an "exempt" appliance ("exempted" from the controls which generally apply in the smoke control area). The Secretary of State for Environment, Food and Rural Affairs has powers under the Act to authorise smokeless fuels or exempt appliances for use in smoke control areas in England. In Scotland and Wales this power rests with Ministers in the devolved administrations for those countries. Separate legislation, the Clean Air (Northern Ireland) Order 1981, applies in Northern Ireland. Therefore it is a requirement that fuels burnt or obtained for use in smoke control areas have been "authorised" in Regulations and that appliances used to burn solid fuel in those areas (other than "authorised" fuels) have been exempted by an Order made and signed by the Secretary of State or Minister in the devolved administrations.

Further information on the requirements of the Clean Air Act can be found here:

<https://www.gov.uk/smoke-control-area-rules>

Your local authority is responsible for implementing the Clean Air Act 1993 including designation and supervision of smoke control areas and you can contact them for details of Clean Air Act requirements.

The Panamera/Vega Panamera stoves may be used in smoke control areas strictly in accordance with these instructions, when burning: UK: Untreated wood logs, natural anthracite or authorised smokeless fuels (authorised under s20(6) of the clean air act 1993) RoI: Wood logs, smokeless fuels or peat briquettes, but not petroleum coke (Control of Atmospheric Pollution Regulations 1970)

## STOVE SAFETY

---

**This appliance becomes extremely hot and can produce poisonous gases. A fire guard should be used if children or the infirm are present. The installer is required to exactly follow these instructions and to completely comply with all relevant local, national and international standards.**

Installing a stove is a 'controlled service', the law expects that it is either supervised by a qualified installer or that the building inspector is informed. Check with your local authority.

**Asbestos:** Your stove does not contain asbestos, but take care to avoid asbestos in an old installation.

**Weight:** Your stove is heavy - take great care when moving it and ensure that the intended fireplace can support the weight - consider fitting a load distributing plate.

### Your Chimney

Once warm, your chimney makes the gas inside it rise, pulling fresh air into the stove to make it work.

Your chimney must:

- Generate a draught in use of at least 12 Pa (0.05ins wg) and not in excess of 25 Pa.
- Be capable of withstanding the temperatures generated.
- Be absolutely incapable of leaking fumes into the dwelling - this will commonly be achieved by it:
  - Being at least 5m high.
  - Terminating at least 1m above any roof ridge.
- Having an internal cross-section not less than 0.018m<sup>2</sup> (e.g.: 150mm dia) and never more than 0.14m<sup>2</sup> (e.g.: 375 x 375mm).
- Being free from even the slightest crack or source of leakage.
- Having no bends sharper than 45°.
- Being entirely free of obstructions and swept by a qualified chimney sweep.
- Being connected to only this stove.
- Being of thick masonry or otherwise adequately insulated.
- Conforming to local building regulations.

Special rules apply where the flue passes through timber, thatch or other vulnerable materials - take specialist advice Although it is possible to access the chimney through the fire with the throat plate removed, fit hatches for cleaning access if needed.

### 125mm Flue Liner

It is recommended to fit with a 150mm liner for best performance, however, If only dry wood or anthracite is to be burnt on this appliance then it is possible to fit with a 125mm liner. **IMPORTANT:** if you intend to burn unauthorised fuels on this appliance then a 150mm liner must be fitted and your lifetime guarantee will be invalidated.

### Your Fireplace

Stoves become very hot, the setting must be made entirely of durable fireproof materials. Thin (<50mm) stone slabs risk cracking unless cut into sections to allow for expansion and backed with a heat resistant concrete. Even beyond the safety clearance, items can become very hot - take great care in siting vulnerable materials like wax, textiles, paper etc.

## Air Supply

Your stove needs air to breathe - there must be a permanent fresh air supply into the space in which it is installed equal to the size given on page 1. This can often be provided by air leaking around door frames etc. (it is commonly accepted that this alone may suffice for appliances <5kW) but in case of any doubt, fit a purpose made air vent. An extractor fan, or another fuel using appliance in the same building, can remove this air. Fit a Carbon Monoxide alarm near to the stove.

## Regarding installations in rooms with extractor fans

For solid fuel appliances: avoid installing extract ventilation in the same room. If mechanical extraction is unavoidable then seek specialist advice to ensure the installation is tested for the safe operation of the appliance.

A suitable test would be to check for spillage when appliances are subjected to the greatest possible depressurisation. A prerequisite for this condition is that all external doors, windows and other adjustable ventilators to outside are closed. The depressurisation at the appliance will depend on the particular combination of fans in operation (fans in the room containing the appliance and fans elsewhere in the building) and the pattern of open internal doors, hatches etc. which is established at the time of the test (when fans should be on their maximum useable setting), and the specific combination causing the greatest depressurisation at the appliance depends upon the circumstances in each case. Several tests (which should include a test with the door leading into the room of installation closed and all fans in that room switched on) may therefore be necessary to demonstrate the safe operation of the appliance with reasonable certainty. The effect of ceiling fans should be checked during the tests. Extra ventilation should be supplied if tests show that this is necessary.

## Stove clearances to non-combustibles

Distance to Non-combustible Materials		
Stove Distance From Wall (x)	Minimum Wall Thickness (t)	Minimum Wall Height (h)
0-50mm	200mm	300mm above height of appliance and at least 1.2m above the hearth
51-300mm	75mm	
>300mm	No requirement	At least 1.2m above the hearth

Solid non-combustible material,  
eg masonry or concrete

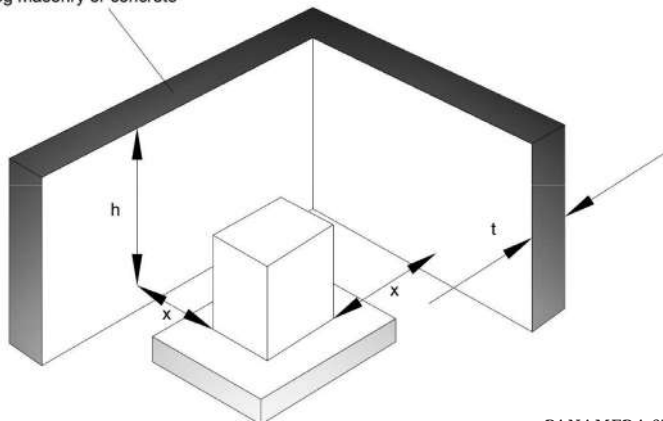

## FITTING

Fasten the flue outlet and blanking plate to the top or back flue outlet opening, on a thin bead of fire cement. Do not over tighten. Place the stove on a non-combustible hearth conforming to building regulations, noting the distances to combustible materials given in the table on the front of this document.

Fix the stove securely to the earth by drilling through the fixing holes inside the stove, into the hearth, with a 6mm masonry drill. Screw down with the bolts and washers provided. If you chose to secure the stove using an alternative method you should seal the two holes in the base of the stove to prevent air being drawn in when the bottom valve is closed. Your stove can be sealed to the chimney using a short (up to about 500mm) length of uninsulated pipe in several ways, four of which are shown below.

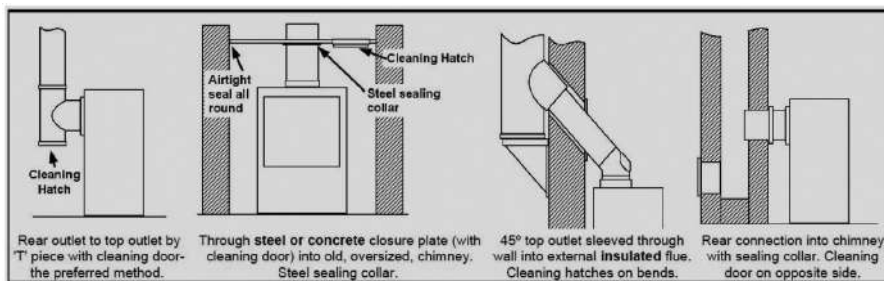
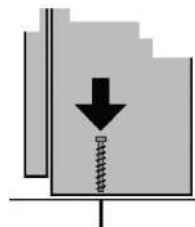

Whichever method is used it is imperative that:

- 1) The route for gases from the stove to the chimney terminal is completely air-tight; even the tiniest gap or crack can spoil the updraught. Seal all joints with fireproof cement and/or heatproof rope.
- 2) It is possible to sweep the entire length - access doors may be required.
- 3) The entire construction is of durable fireproof materials.

### Check the Installation

Once installed, light the fire, demonstrate it to the householder and check that:

- 1) It burns controllably and does not emit fumes to the room.
- 2) The route for gases from the stove to the chimney terminal is completely airtight, unobstructed and able to be swept.
- 3) The entire construction is of durable fireproof materials.
- 4) The flue presents a draught in use of at least 12Pa and not in excess of 25 Pa.



### **Panamera Eco Supreme**

- 1) Lift the Panamera stove onto the top of the base and ensure that it is correctly aligned. Please note that the stove is a heavy appliance and two people should lift it carefully.
- 2) Take the ash bin out of the stove and remove the two vermiculite insulation bricks that it sits atop from the base.
- 3) Place two washers onto the two bolts supplied and drop the bolts through the two holes in the base of the stove. If everything is correctly aligned these will also go through the holes in the top of the base.
- 4) From below the base affix the remaining two washers and secure with the two nuts. Ensure the nuts are suitably tightened.
- 5) Use the two holes in the base of the stove to affix it to the hearth using the special bolts and washers that are supplied with the stove. It is often beneficial to mark and drill these holes before moving the stove into position.

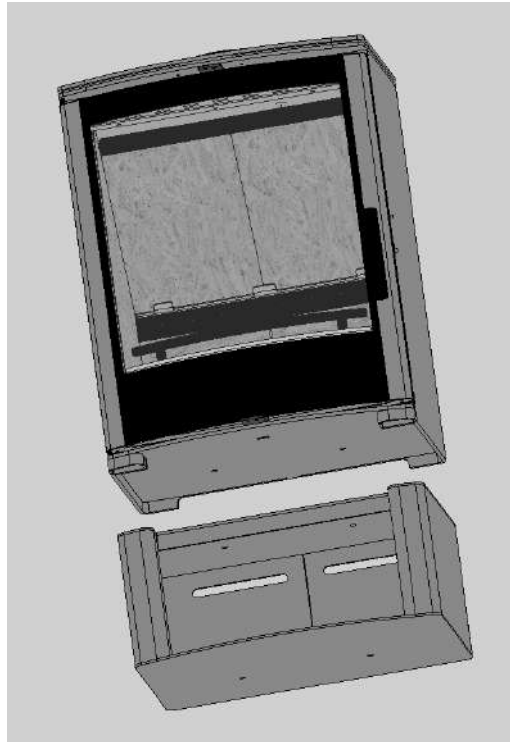

### **Flue Ring Fitting**

The Flue Collar should be attached to the stove top as per the illustration.

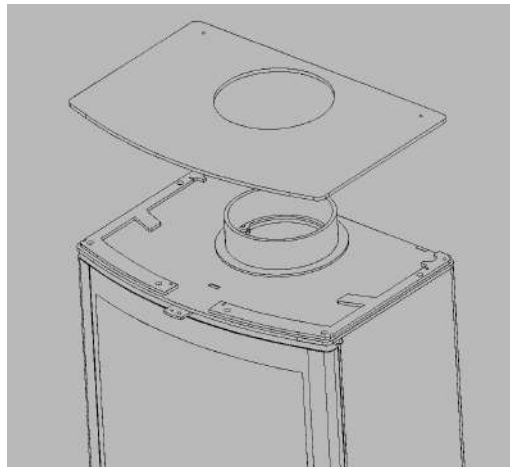

## LIVING WITH YOUR STOVE

**Every fuel, chimney and condition of use is different. Only experience will show which are the best settings for you.**

**Lighting:** If lighting after a period of non-use, do check that the flueways and chimney are completely clear. Place two or three firelighters close together, or screwed-up paper covered with dry sticks, at the back of the grate and light them. When they are burning well gently cover them with very dry fuel, close the door and set the air controls to the 'high' position (see 'Control'). When the fire is burning well, move the controls to the lowest practical setting.

**Filling:** These are very efficient stoves, you don't have to pile them up with huge amounts of fuel. Just one or two logs of about 1kg each, or mineral fuel mounded up in the centre is all that is needed. Don't fill above the level shown in the diagram below.

**Dampers left open:** Operation with the appliance dampers or air controls left open can cause excess smoke. The appliance must not be operated with air controls, appliance dampers or door left open except as directed in these instructions.



**Control:** How fast the fire burns depends on how much air reaches the fuel. The stove has two air controls, one below the window ('primary' ❶) and one above ('airwash control' ❷).

Move the slides right for 'high' and left for 'low'. They can get very hot so move them with the poker tool supplied or use a glove. To open the door, fully lift the door handle and pull. To close the door, fully lift the handle, push the door closed and then push the handle forwards to lock. Open the door (never past 90°!) only for refuelling and de-ashing.

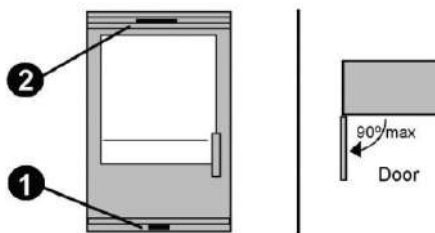

Keep it tightly closed in use. When using wood it is usually best to have the primary control ❶ completely closed and adjust the burning rate using the airwash ❷ control. Hard fuels like anthracite work best with the airwash closed and the primary open.

**Emptying Ashes:** Only empty ashes when the fire is cold. Use the tool or a glove to open the door. Stir the fire with a poker before lifting out the ashbin. Remember to let ash cool before disposing in plastic sacks or dustbins. There is no need to empty every last speck but ash from mineral fuels should never be allowed to build up so that it comes into contact with the underside of the grate.

**Extended Burning:** Our stoves are intended for quick heat-up intermittent use. While well capable of lasting for many hours, they are not designed for overnight burning. For best extended burning results allow the fire to burn down to a low, hot, firebed and fully fill with a hard fuel such as anthracite (c30mm size is best) and set the air controls to 'low'.

**Keeping the window clean:** Simply operating the stove for a few minutes at high output will often burn off any deposits left by tarry or wet fuels. Severe stains can be removed when cold with a domestic bleach cleaner. The window is not glass but a transparent ceramic, it may develop tiny hairline cracks, these are harmless and a characteristic of the toughest heat-resistant material known. Reduce the risk of staining by using only very dry fuel and keeping the airwash  control at least a little open.

**Opening the door:** This stove is designed to be operated only with the door closed. The door handle can get very hot so use the poker tool or a glove. Open the door very slowly to minimise fume emission and prevent hot fuel falling out.

**Summer shut down:** Before a long period of non-use, empty fuel and ash, remove the throat plate and leave all air controls open to allow ventilation and reduce condensation.

**Fuels:** There is no 'perfect' fuel so we strongly recommend that you try a selection of fuels (or mixtures) to find which suits you best. Do avoid dusty materials such as sawdust, they can burn far too violently.

**Smoke Control:** In certain areas special rules apply to reduce smoke nuisance. Check with your local authority.

**Wood:** Wood only emits as much carbon to the atmosphere as the tree took in when growing so wood is considered the 'carbon neutral' fuel. When wood is cut down its cells are full of water. Burning such wet or 'green' wood wastes heat in making steam and produces flammable acidic tars which will cling to, and rapidly damage, your stove and chimney. Split logs will typically take two years to become reasonably dry, round logs much longer. Cracks in the ends, a hollow sound when tapped and bark falling away are all signs that a log may be ready for use. The fine, white residue produced when wood burns is not ash, but the remains of cell walls which can burn if kept hot enough, so don't de-ash a fire until absolutely necessary when using wood.

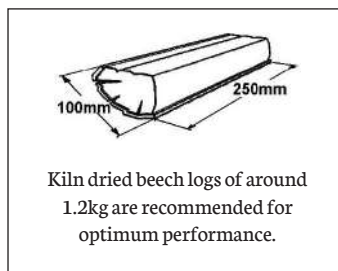

These appliances are authorised for use in smoke control areas of the UK when burning wood. For best performance, and always for low smoke emission:

- Split logs lengthways for drying
- Use logs no bigger than about 100mm x 250mm
- Ensure logs are absolutely dry (less than 15% moisture)
- Fill the stove 'criss-cross' so air can circulate between logs
- Fill 'little & often'
- Always have the airwash control  at least a little open
- When first lighting, or reviving a fire from embers, use only very small, thin, dry, sticks
- Never operate with the door open
- Don't overfill the firebox

**Anthracite:** (Smokeless) A natural hard, shiny form of coal. Slow to light, it can burn for very long periods with great heat. Despite its high price per bag it generally works out to be one of the cheapest of all fuels. Use the small ‘nuts’ size.

**Briquettes:** Compressed blocks of fuel, generally able to burn for long periods and remarkable for their consistency. ‘Homefire’ and ‘Phurnacite’ are smokeless types while other brands are made from lignite, peat or housecoal. Only burn smokeless briquettes that are <2% sulphur content, these will be labelled up as “HETAS approved” or “DEFRA authorised for use in a smoke control zone”. Cheaper smokeless briquettes are oil based and have a much higher sulphur content than the approved briquettes, these are not authorised for use on this appliance. If in doubt consult your retailer.

**Peat (NOT AUTHORISED):** (Not smokeless in the UK. Smokeless in the RoI) Sod turf must be thoroughly dry.

**Lignite (NOT AUTHORISED):** (Not smokeless) A natural mineral, between peat and coal. It lights easily and burns well, but produces much ash.

**Housecoal or Bitumous Coal (NOT AUTHORISED):** (Not smokeless) Makes a lot of tarry smoke and large volumes of flammable gas which makes it difficult to control and risk explosions. Despite its low cost it rarely represents good value for money. Never use housecoal.

**Coke (NOT AUTHORISED):** (Smokeless) Coke is coal from which the smoke has been removed. Sometimes difficult to light, it burns very cleanly.

**Petroleum Coke (NOT AUTHORISED):** (Smokeless in the UK, forbidden in smokeless zones in the RoI) Sold as ‘Petcoke’, ‘Longbeach’ and under various proprietary names, is made from oil. Easy to light and control, its exceptional heat and lack of protective ash mean that it MUST NOT be used unless mixed with another fuel. Grate and liner life will be drastically reduced when using petroleum coke.

**Household Wastes (NOT AUTHORISED):** Some plastics give off toxic fumes when burned and remember that batteries and aerosols explode! The stove is not an incinerator, so only use the recommended fuels and NEVER use liquid fuels in any form.

## THE USE OF UNAUTHORISED FUELS CAN DAMAGE YOUR STOVE AND WILL INVALIDATE YOUR LIFETIME GUARANTEE

### Stove and Brick Set

- A Right Side Brick
- B Left Side Brick
- C Left Back Brick
- D Top Brick (Pair)
- E Right Back Brick
- F Base Brick (Pair)

- 1 Stove Body
- 2 Removable Latch Pin
- 3 Stainless Steel Grate
- 4 Top Plate
- 5 Flue Collar
- 6 Log Retaining Bar
- 7 Ash Bin
- 8 Rear Baffle
- 9 Flue Blanking Plate

- 10 Vermiculite Retaining Bar
- 11 Vermiculite Brick Set
- 12 Stove Door
- 13 Fixing Bolts
- 14 Fixing Bolts
- 15 Fixing Bolts
- 16 Fixing Bolts
- 17 Handle Assembly

## SPARE PARTS

Please see listed  
parts on the left  
hand page

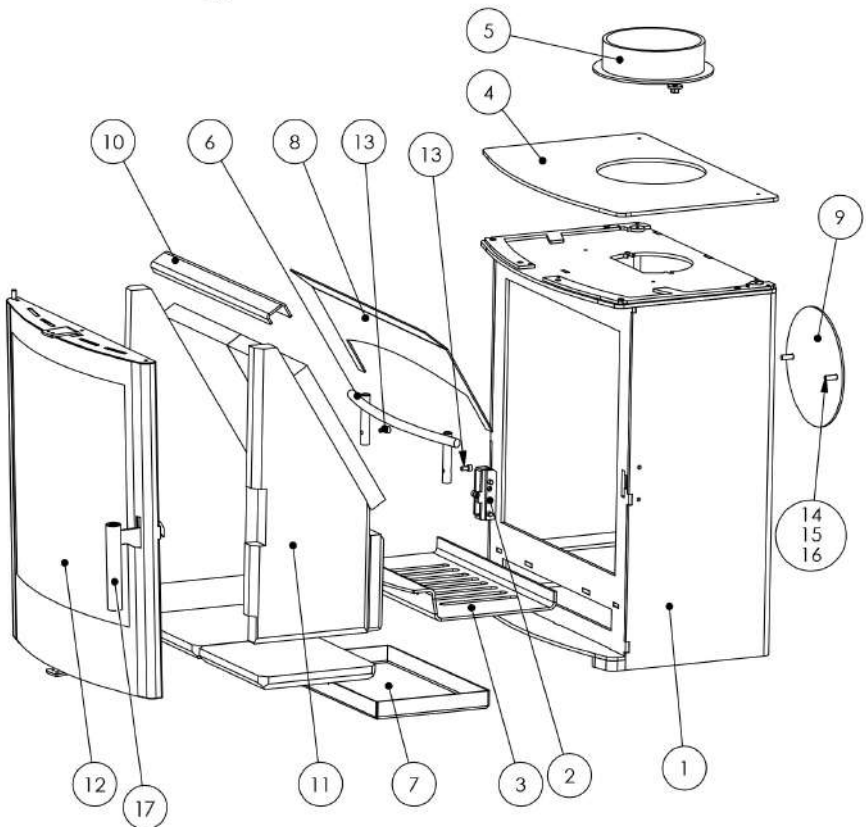
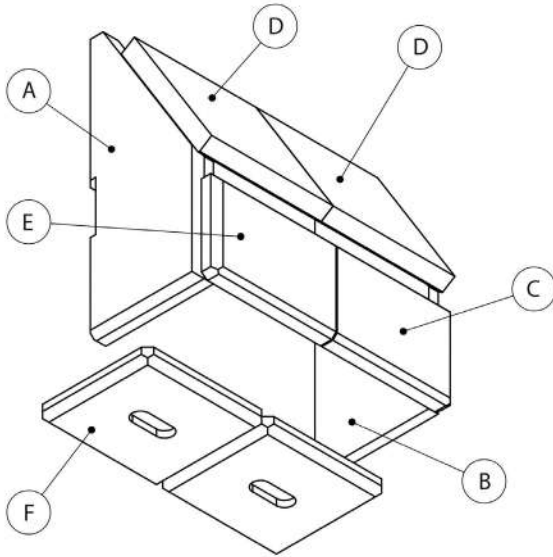

## TROUBLESHOOTING

---

Problems like those listed here are usually due to some difficulty with the installation, chimney or fuels, so please check back through these instructions carefully. If necessary seek specialist advice.

**Smoke from the chimney:** It is quite normal for a little smoke to be emitted from the chimney when the fire is cold, so start the fire using only a very little fuel. When using wood always ensure that the primary control ● is completely closed and adjust the burning rate using the airwash ● control. Use only very dry wood or smokeless fuels.

**Poor Heat Output:** A stove can heat a typical room of about 12m<sup>3</sup> volume for each kW of output, so a 5kW model can heat up to (12 x 5) 63m<sup>3</sup>, a room of about 5m square. The actual size depends on the insulation and air-change ratio of the room. To attempt to heat a larger room will result in excessive fuel consumption and damaging overheating.

**Lack of Controllability:** Wood and some other fuels may burn excessively until the gasses in them have been used up. You can reduce this effect by making sure that the fire is set to 'low' for a while before refuelling and checking that the door seals fully.

**Condensation:** Condensation onto cool surfaces inside the stove can be severe if fuel is in any way damp, use only very dry fuel.

**Over-Firing:** It is possible to leave the fire too long with the controls set too high leading to 'over-firing' seen as glowing metal parts, excessive chimney temperature and risk of parts failing or chimney fires. Always set controls to the lowest practical setting. A chimney thermometer, from your local stove shop, can help.

### Smoke Coming Into Room

Fumes are poisonous - smoke emission must never be tolerated, causes might be:

- New stove: There is often a smell and sometimes visible fumes as the paint cures. This normally stops after an hour or so and we advise that you open a window when firing up a new stove for the first time.
- Inadequate seals: Are all flue pipes and connectors absolutely gas tight? Even the tiniest crack or gap can spoil the draught. Does an inset appliance fully seal against the fireplace?
- Blocked throat plate: Has soot or ash collected on the throat plate above the inner back part of the firebox?
- Unsuitable, blocked or un-swept chimney: The first requirement for correct operation is a sound chimney. Check the requirements earlier in this document and in case of any doubt engage a professional sweep or chimney engineer.
- Poor air supply: Lack of air to the fire is a common cause of smoking and poor performance. Air supply problems may be worse in certain wind conditions (often incorrectly ascribed to 'downdraft' which is in fact very rare), where air can be sucked out of the room. The answer is to fit an air vent, as near to the fire as possible, facing into the usual wind direction.
- Downdraught: Wind can blow down a chimney if there is something higher nearby such as a tree, hill or high building. Fitting an anti-downdraught cowl to the chimney top can cure this. Types which cannot be swept through are not recommended.
- Poor chimney draught: Chimney draught in use MUST be at least 12Pa.

**Chimney Fire:** In the rare event of deposits inside the chimney igniting (roaring sound + dense smoke and sparks from the chimney) immediately close the door, shut all air controls, evacuate the premises and call the fire brigade. Prevent fires by using very dry fuel and having your chimney swept regularly.

### **Maintenance**

**Monthly:** Check that the flue is clear and unblocked, and that the door seals are sound.

**Annually:** Sweep the chimney, the entire length of the chimney from stove to outlet should be swept.

**New Parts:** Your stove has been extensively tested for safety – please don't try to modify it and always obtain genuine spare parts from your stove shop or the manufacturer.

**Surface Finish:** Wipe the stove body with a slightly damp cloth when cool. Never use aerosol spray or wax near the hot fire – they can ignite. Painted steel parts can be refurbished using special stove spray paint.

Your stove generates very high temperatures; eventually the internal parts will require replacement.

Our designs are registered at the UK patent office and protected by Copyright © and UK Design Right. Certain parts are UK Patent Applied For. This document issued March 2018. We are always striving to improve these products and may change their specification without notice.



For South of England sales please contact:

Capital Fireplaces Ltd  
Unit 12-17  
Henlow Trading Estate  
Henlow Camp  
Bedfordshire  
SG16 6DS  
Tel: 01462 813138  
Fax: 0800 980 4847  
Email: [sales@capitalfireplaces.co.uk](mailto:sales@capitalfireplaces.co.uk)  
Website: [www.capitalfireplaces.co.uk](http://www.capitalfireplaces.co.uk)

For North of England sales please contact:

Percy Doughty & Co Ltd  
Imperial Point  
Express Trading Estate  
Stone Hill Road  
Farnworth  
BL4 9TN  
Tel: 01204 868550  
Fax: 01204 868551  
Email: [sales@percydoughty.com](mailto:sales@percydoughty.com)  
Website: [www.percydoughty.com](http://www.percydoughty.com)