

# SOLUS iX SERIES

Premium Electric Fires



## Installer Instruction Manual & User Guide

PLEASE READ THESE INSTRUCTIONS CAREFULLY BEFORE INSTALLATION  
AND OPERATION. KEEP THEM IN A SAFE PLACE FOR FUTURE REFERENCE.



IX15IM REV A 06/24





# CONTENTS

IMPORTANT INFORMATION	PAGE 4
TECHNICAL INFORMATION	PAGE 6
PRODUCT DIMENSIONS	PAGE 7
PARTS CHECKLIST	PAGE 8
INSTALLATION	PAGE 9
STUD/FEATURE WALL	PAGE 9
GLASS REMOVAL – ACCESSING PARTS	PAGE 10
ASPECT SELECTION	PAGE 11
POWER CABLE	PAGE 12
FUEL BED UPLIGHTS	PAGE 12
FUEL BED SETUP	PAGE 13
OPERATION	PAGE 19
MANUAL CONTROL	PAGE 19
REMOTE CONTROL	PAGE 20
APP CONTROL	PAGE 22
VOICE CONTROL	PAGE 24
SOLUS AMBIENT LIGHT KIT	PAGE 27
CARE AND MAINTENANCE	PAGE 28
TROUBLESHOOTING	PAGE 28
WARRANTY	PAGE 29

## IMPORTANT INFORMATION

**Before installation, check that all parts included are undamaged. If the appliance is damaged, check with the supplier before installation and operation. If the supply cord is damaged, it must be replaced by the manufacturer, its service agent or similarly qualified persons in order to avoid a hazard.**

**CAUTION:** In order to avoid a hazard due to the inadvertent resetting of the thermal cut-out, this appliance must not be supplied through an external switching device, such as a timer, or connected to a circuit that is regularly switched on and off by the utility.

**Do not** use the appliance outdoors.

**Do not** use the appliance in the immediate surroundings of a bath, a shower or a swimming pool.

**Do not** leave the appliance unattended during use.

**Do not** run the mains cable under carpet, rugs, etc.

**Do not** locate the appliance immediately below a fixed socket outlet or connection box.

**Do not** install the appliance using an extension cord.

**Do not** install the appliance in an open flue.

**Do not** insert any objects into the appliance.

**Do not** operate the appliance near flammable materials or fire.

**Do not** clean the appliance with abrasive cleaners.

**Do not** use this fire in rooms that have explosive gas in them (for example petrol), or if you are using solvents, glue, aerosol spray or in flammable paints, as these may catch fire.

**Do not** use this appliance in small rooms when they are occupied by persons not capable of leaving the room on their own, unless constant supervision is provided.

**Do** switch off and unplug the appliance from the main socket when not in use or before cleaning and maintenance.

**Do** keep the appliance away at least 1 meter from furniture, curtains or other combustible material when in use.

**Do** ensure the plug remains easily accessible after installation of the appliance.

**Do** use this appliance on a horizontal and stable surface.

**CAUTION:** Some parts of this product can become very hot and cause burns. Particular attention has to be given where children and vulnerable people are present.

Children of less than 3 years should be kept away from the products unless continuously supervised. Children aged from 3 years and less than 8 years shall only switch on/off the appliance provided that it has been placed in its intended normal operating position and they have been given supervision or instruction concerning use of the appliance in a safe way and understand the hazards involved. Children aged from 3 years and less than 8 years shall not plug in, regulate and clean the appliance or perform user maintenance.

**NOTE:** A dedicated, properly fused 13 Amp circuit is required, rated for the appropriate voltage (230-240V). An isolation switch should also be incorporated in cases where the product plug is inaccessible after installation.

**NOTE:** This appliance must be earthed.

**WARNING!** Construction and wiring (including electrical safe zones) must comply with local building codes and other applicable regulations to reduce the risk of fire, electric shock and injury to persons.

**WARNING!** To reduce the risk of fire, electric shock or injury to persons, always use a licensed electrician.

## IMPORTANT INFORMATION

**WARNING!** Information for authorized person or service center only: A non-rewireable plug fitted with a 13A fuse is supplied. Should the fuse or plug need replacing, and you are competent to do so, it must be replaced with a 13A fuse or plug being 13A BS1363A approved.

**WARNING:** In order to avoid overheating, do not cover the heater or air vents located on the appliance or obstruct the air circulation around the appliance.



**WARNING! DO NOT COVER**

## TECHNICAL INFORMATION

	iX15
Weight (kg)	73
Dimensions (mm)	H586 x W1506 x D497
Supply Voltage	AC 230-240V 50Hz
Max. Power Consumption	1830-2000W
Power for Flame Effect	75W
Power for Ambient Light Kit	9.6W

HEAT OUTPUT	SYMBOL	VALUE	UNIT
Nominal Heat Output	$P_{nom}$	2	kW
Minimum Heat Output	$P_{min}$	1	kW
Maximum Continuous Heat Output	$P_{max}$	2	kW
AUXILIARY ELECTRICITY CONSUMPTION			
At Nominal Heat Output	$eI_{max}$	12.5	W
At Minimum Heat Output	$eI_{min}$	12	W
In Standby Mode	$eI_{SB}$	3	W

TYPE OF HEAT OUTPUT / ROOM TEMPERATURE CONTROL	YES / NO
Single stage heat output and no room temperature control	NO
Two or more manual stages, no room temperature control	NO
With mechanic thermostat room temperature control	NO
With electronic room temperature control	YES
Electronic room temperature control plus day timer	YES
Electronic room temperature control plus week timer	YES
OTHER CONTROL OPTIONS	YES / NO
Room temperature control, with presence detection	NO
Room temperature control, with open window detection	YES
With distance control option	YES
With adaptive start control	YES
With working time limitation	NO
With black bulb sensor	NO

ITEMS	MAIN CONTROL BOARD	WiFi MODULE	REMOTE CONTROL
Hardware	RC01-078F01	WBR03	RC455A V2.0
Software/Logic	V1.0.1	/	C.0.5
Frequency	FSK 433.92MHz	2.4GHz	FSK 433.92MHz
Maximum Transmit Power	80mW	18dBmW	80mW

# PRODUCT DIMENSIONS

FIG.1

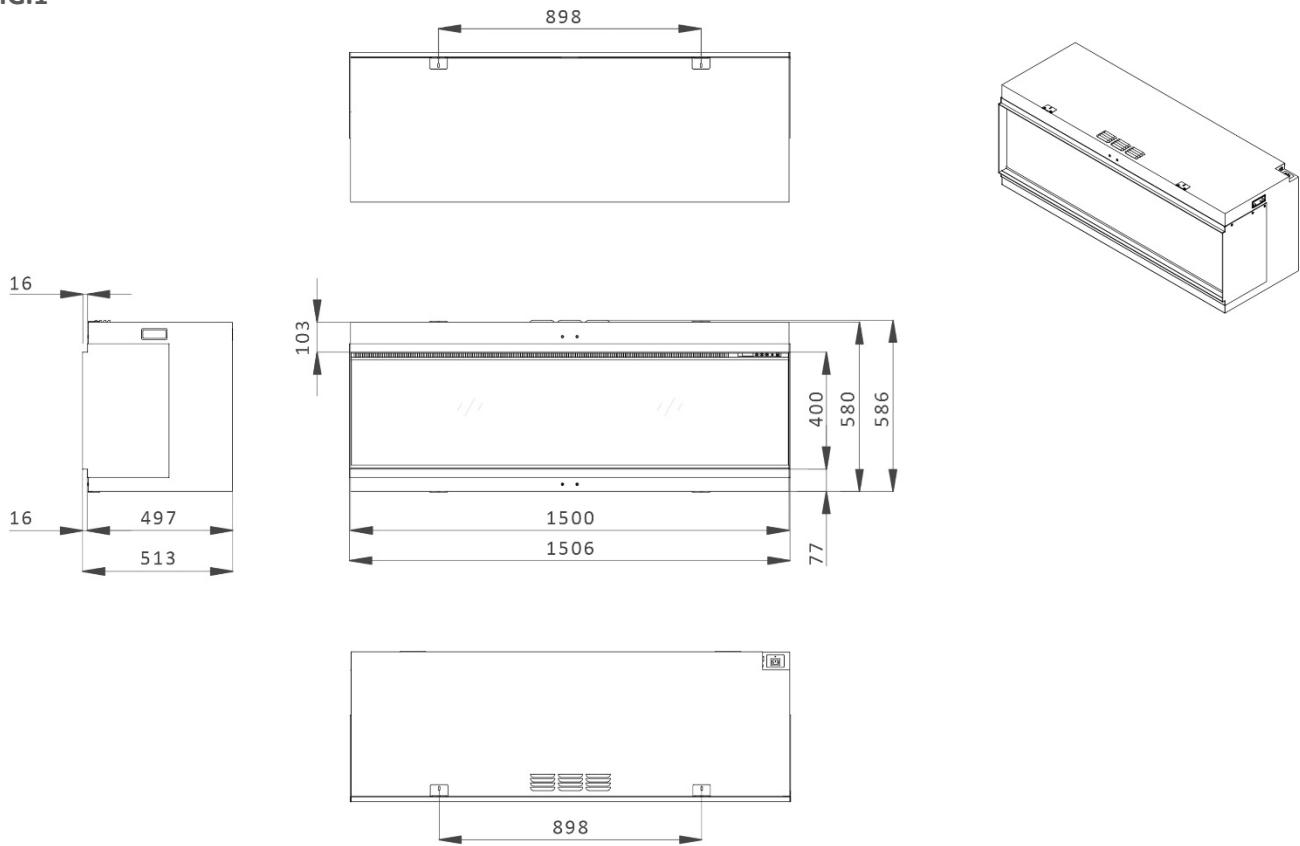
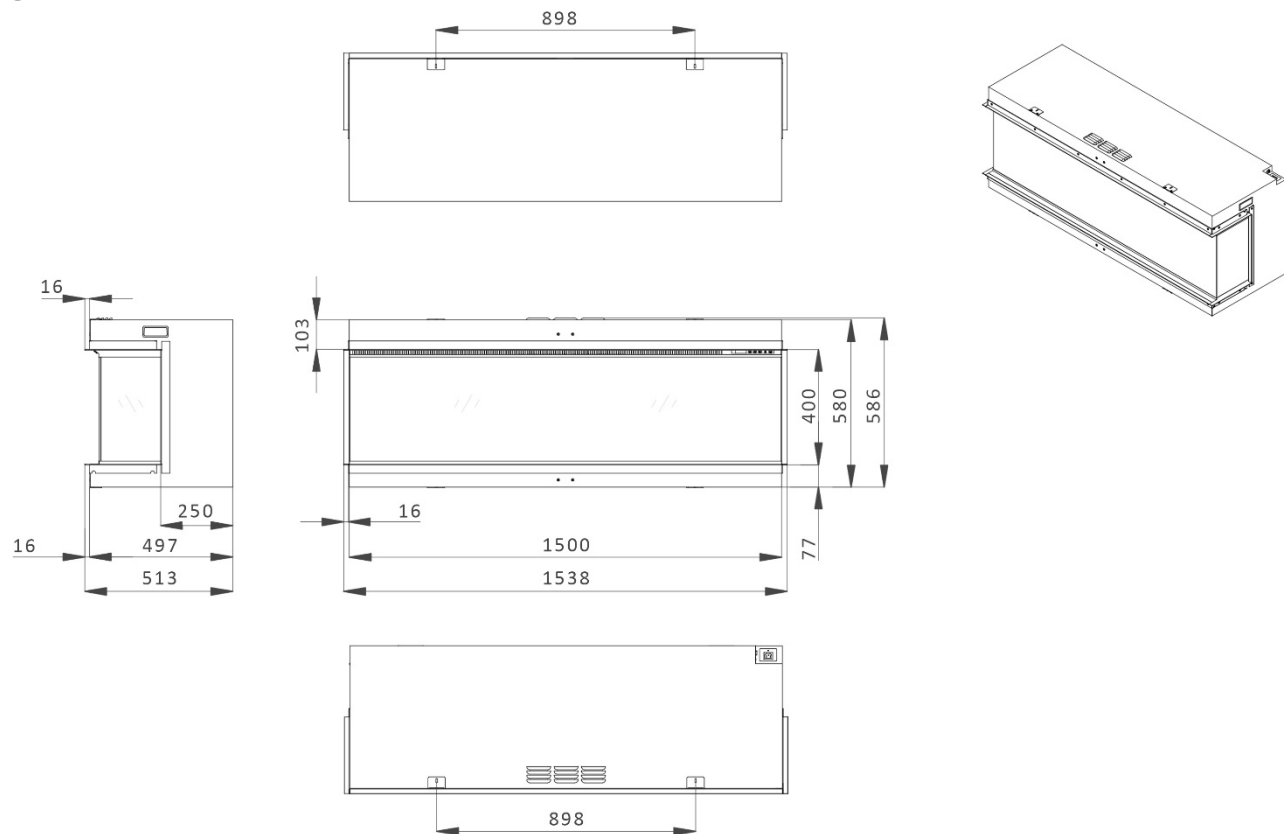
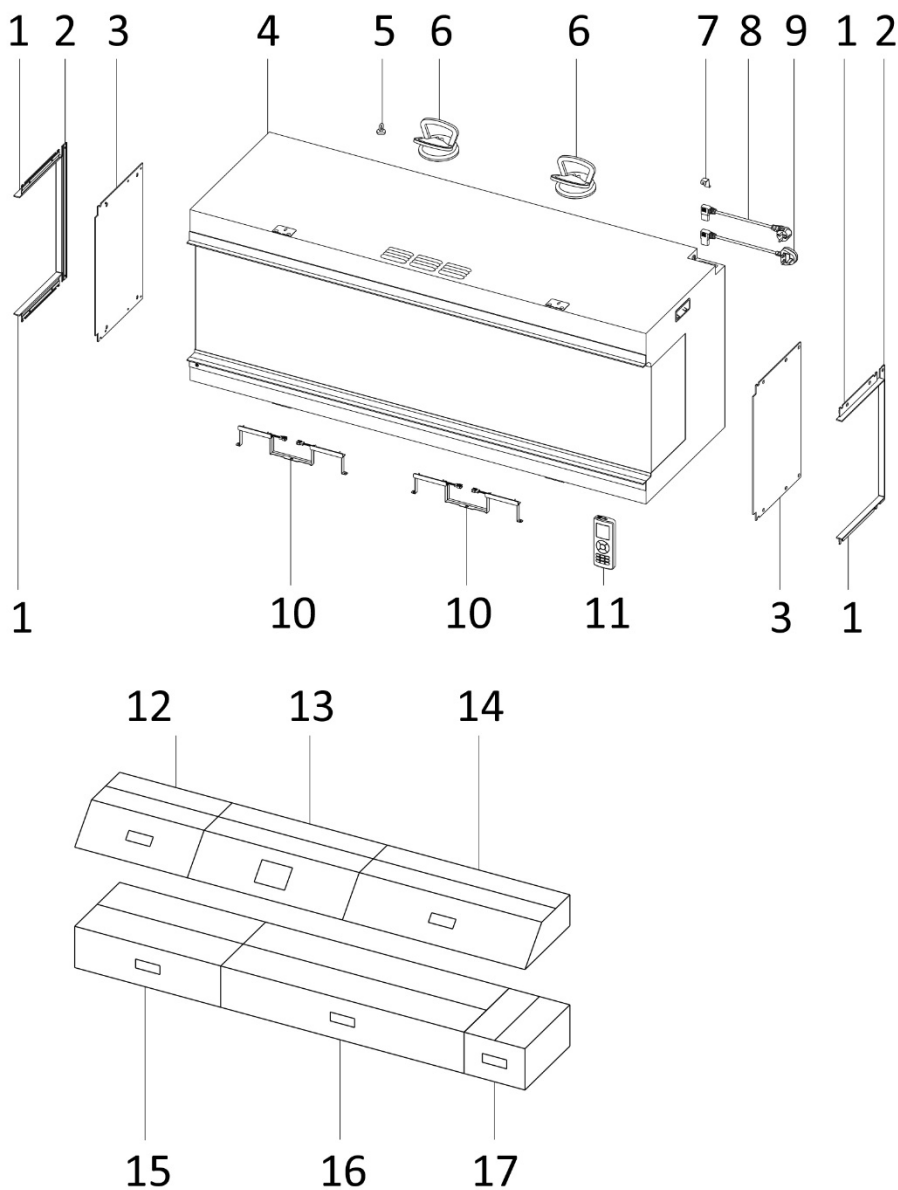

FIG.2



# PARTS CHECKLIST

FIG.3



BOX 1
Black glass ember (x3 bags)
Grey ceramic chips (x1 bags)
Black ceramic chips (x1 bags)

BOX 2
User manual/warranty card
Remote handset
AAA battery x2
Power cable UK
Power cable EU
Power cable securing bracket
ST4x8 screw
Side glass trim (top/bottom) x4
Side glass trim (side) x2
Back panel uprights x2

BOX 3
Black resin embers (x2 bags)
Clear resin embers (x2 bags)

No.	DESCRIPTION	No.	DESCRIPTION
1	Side glass trim (top/bottom) x4	10	Back panel upright x2
2	Side glass trim (side) x2	11	Remote handset
3	Side glass panel (x2)	12	Box 1
4	iX15	13	Box 2
5	Magnetic tool	14	Log set A
6	Glass sucker x2	15	Log Set B
7	Power cable securing bracket	16	Log Set C
8	Power cable EU	17	Box 3
9	Power cable UK	18	



# INSTALLATION

## STUD/FEATURE WALL

The manufacturer does not accept any liability for any injuries or damages that may occur due to improper handling or installation. Ensure that the wall upon which the appliance is to be installed and any wall fixings used are sufficiently strong enough to hold the weight of the appliance. Plasterboard alone is not considered a structural material and it is not recommended to rely solely on plasterboard fittings to support the weight of the appliance. If the appliance or any structure linked to the appliance is to be fitted to a wall with a timber frame construction, adequate wooden supporting members must be fitted using appropriate fixings. If this is not possible then steps must be taken to strengthen the wall before installation.

When creating a timber framework, a minimum thickness of 50mm timber must be used.

There are four framing plates fixed to the appliance: two along the top front edge and two along the bottom front edge. Bend these at an angle of 90 degrees to the appliance, then secure to the timber framework using the four timber screws provided.

FIG.4

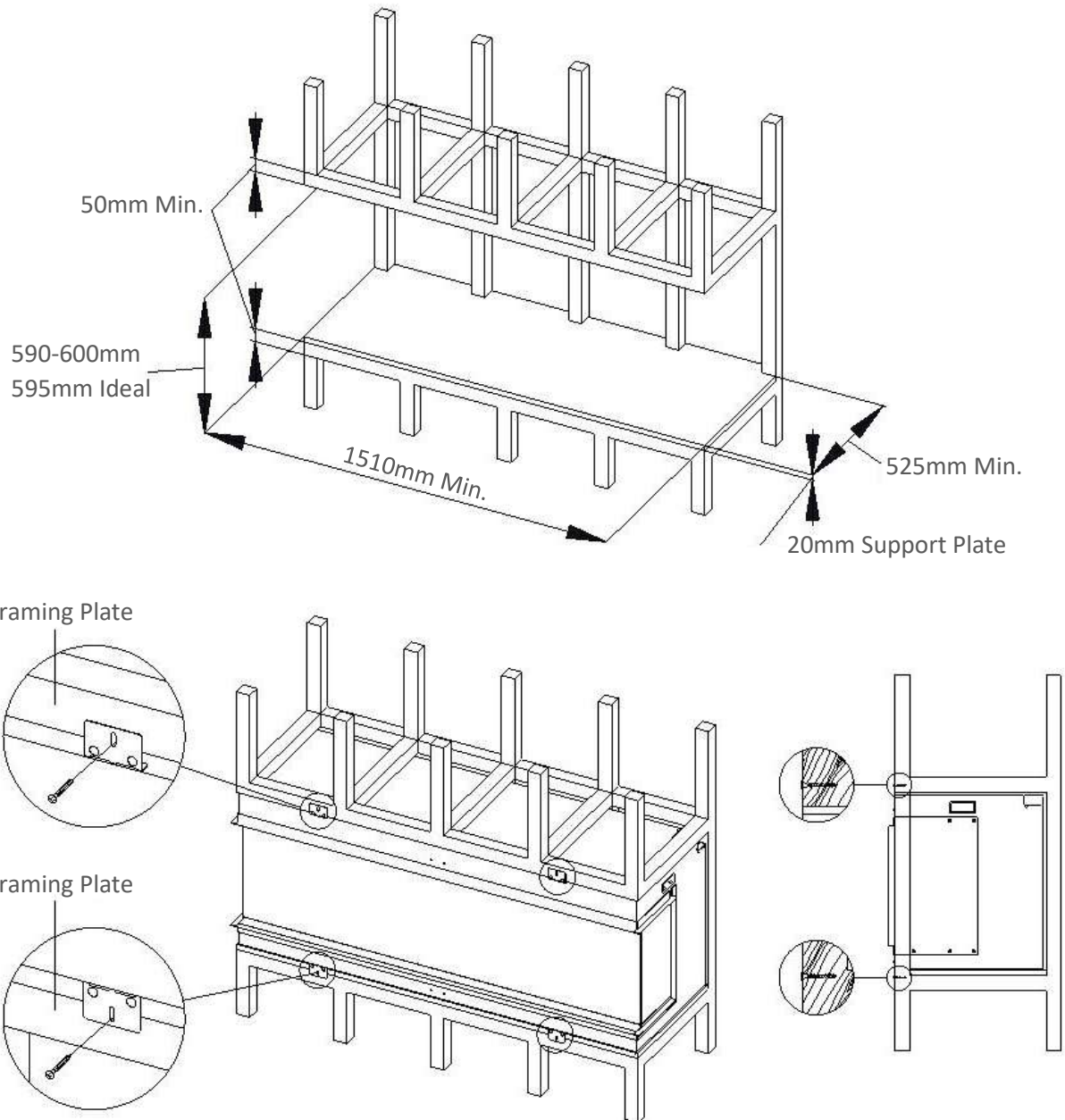

## INSTALLATION

Before installation, check that all parts are included and undamaged. If the appliance is damaged, check with the supplier before installation and operation. If the mains power supply lead is damaged in any way, it must be replaced by a suitable equivalent approved by the manufacturer.

The main box contains the appliance, 2 x glass suckers and 1 x magnet tool. Packed with the appliance (behind the glass panel) are additional boxes each with a contents list printed on the outside of each box.

### PREPARING THE APPLIANCE

It is recommended that you prepare the appliance in the final place of intended installation, secured to any necessary framework or studwork. Any movement after preparation may result in the movement of the precisely arranged fuel bed elements.

#### GLASS REMOVAL – ACCESSING PARTS

To gain access to various contents required for installation, follow these steps:

Step 1: Remove the transit bar from the front of the appliance. Re-fit the screws to the appliance and discard of the transit bar – Fig.5.

Step 2: Using the magnetic tool, attach to the glass retaining bar situated in front of the glass panel and lift up and away from the appliance to reveal the channel below – Fig.6.

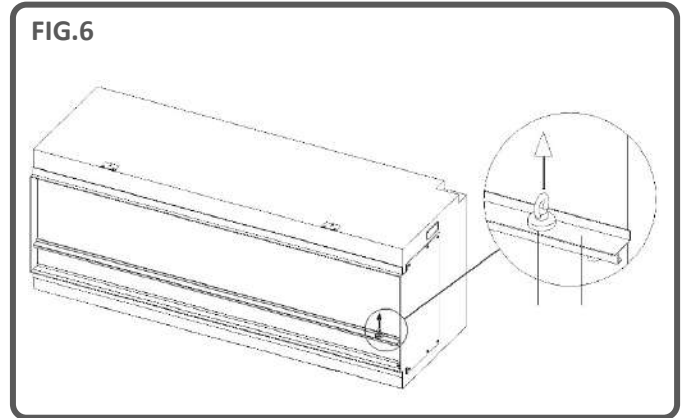
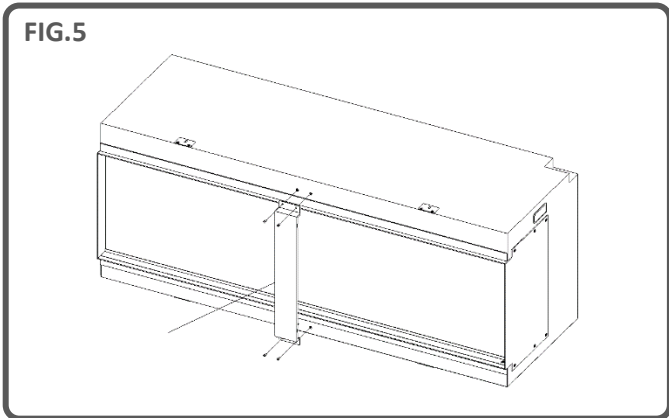

Step 3: Using the 2 suckers provided, lift the glass outwards and carefully guide the bottom edge into the channel. Angle the top edge of the glass away from the appliance and lift out. Place aside in a safe location – Fig.7 & Fig.8.

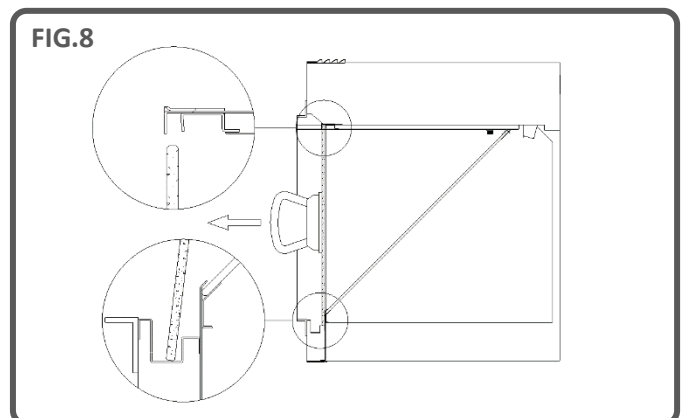
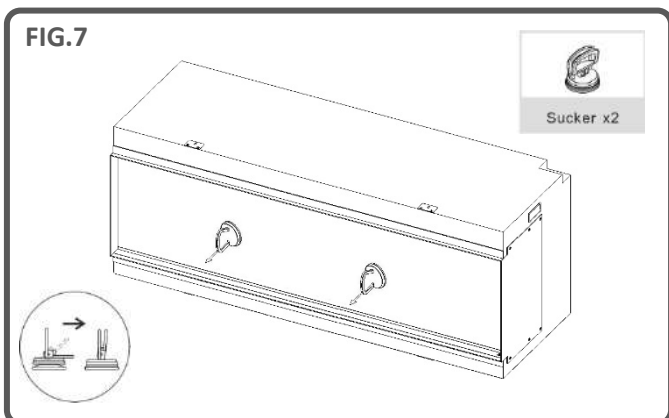

# INSTALLATION

Step 4: To remove the angled glass panel, locate the two steel plate brackets that are secured using a thumbscrew; one at each top corner of the glass. Turn the thumb screws anti-clockwise and remove the brackets.

Using the 2 suckers provided, first lift the glass upwards, then carefully guide the bottom edge upwards and out of the appliance. Place aside in a safe location – Fig.9.

The component boxes and cardboard inserts can now be safely removed from the appliance. Take care not to damage the LCD screen in the ceiling of the appliance when removing the items.

**IMPORTANT:** When replacing the angled glass panel, the correct surface must be facing upwards. See the stickers on the glass panel for guidance. Replace the glass in the reverse order to initial removal, ensuring that both steel plate brackets are fitted and secured using the thumbscrews.

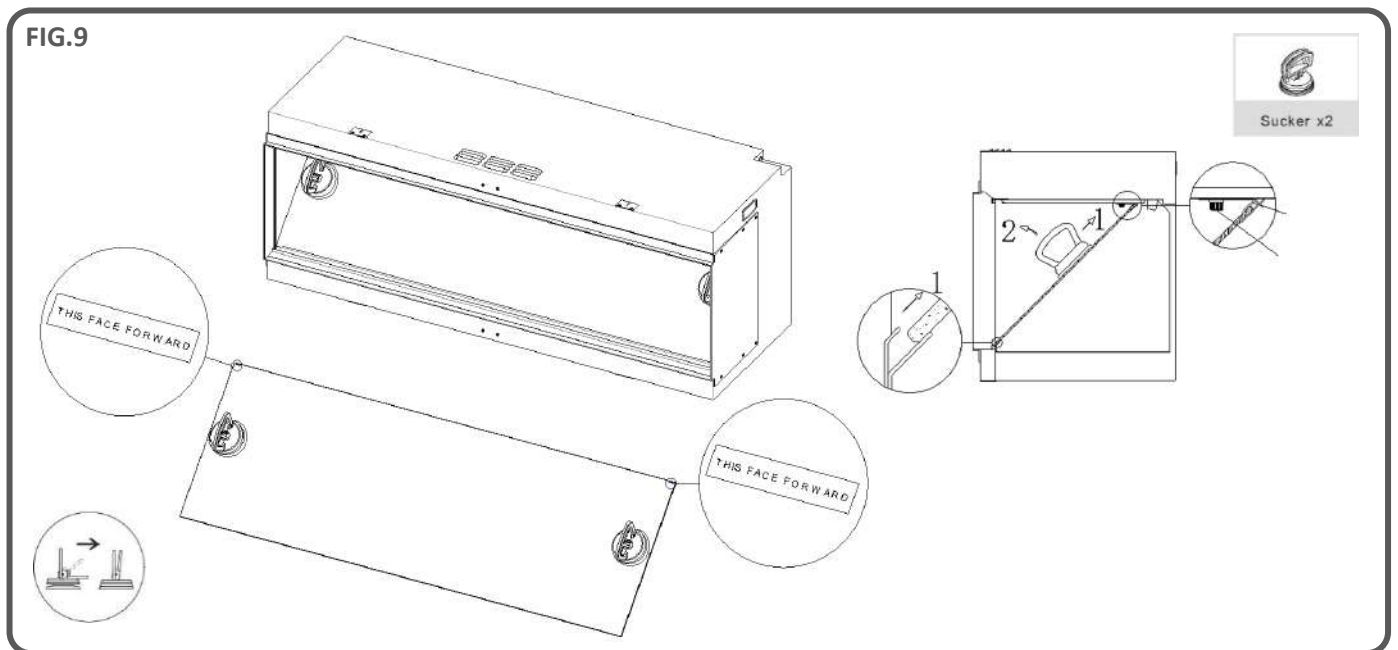

## ASPECT SELECTION

The appliance can be installed in three different aspects:

- Front (1 glass panel)
- Corner (2 glass panels)
- Panoramic (3 glass panels)

### Front Aspect

Your appliance will arrive in a **front** aspect with metal side panels already fitted.

### Corner Aspect

For a **corner** aspect, choose which side you want to feature a glass panel and remove the 6 screws that secure the metal side panel to the appliance. Carefully remove the panel and keep the screws in a safe place. Using the removed screws, take **2 top/bottom** side glass edge trims and **1 side** glass edge trim and screw them to the appliance as shown below – Fig. 11 & 12.

FIG.10

Front Aspect

Panoramic Aspect

Left Corner Aspect

Right Corner Aspect

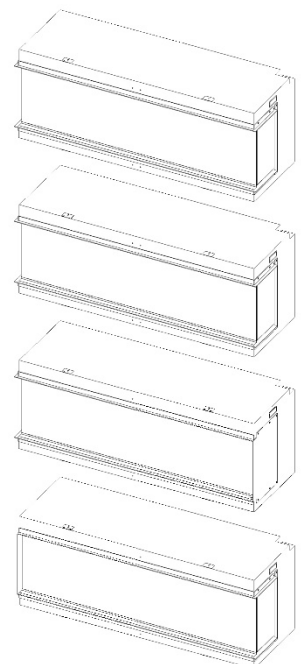

# INSTALLATION

## Panoramic Aspect

For a panoramic aspect, repeat the corner aspect procedure on the opposite side of the appliance – Fig. 11 & 12.

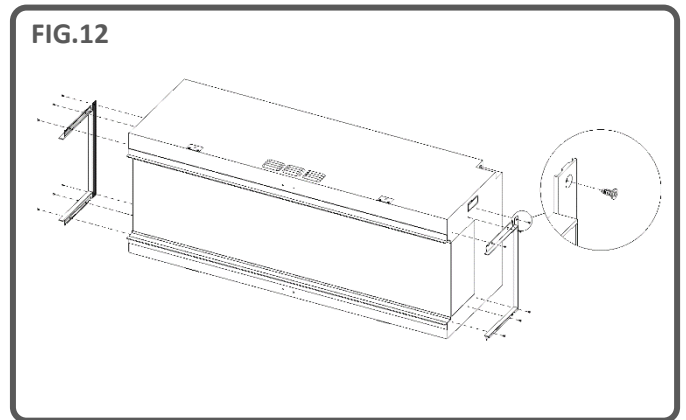
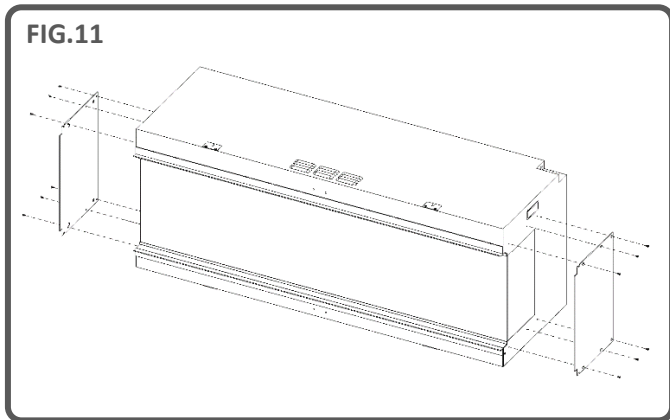

## POWER CABLE

After inserting the power cable into the socket on the top right side of the appliance, secure in place using the power cable securing bracket and ST4\*8 screw – Fig.13.

## FUEL BED UPLIGHTS

With the front glass panel and angled glass panel removed from the appliance, take the two Fuel Bed Uplights and secure in place on the fuel bed using the thumbscrews provided – Fig. 14.

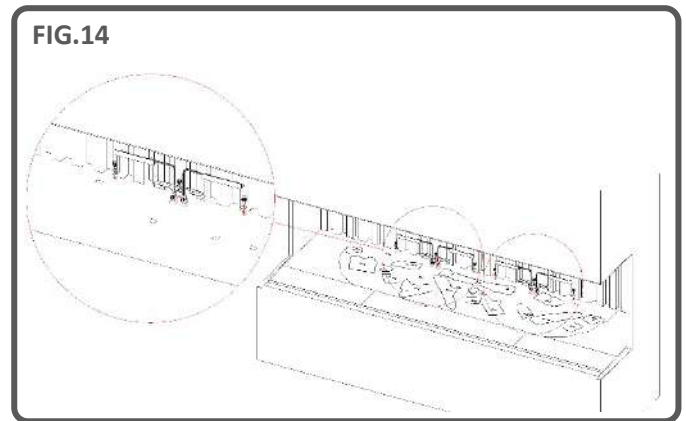
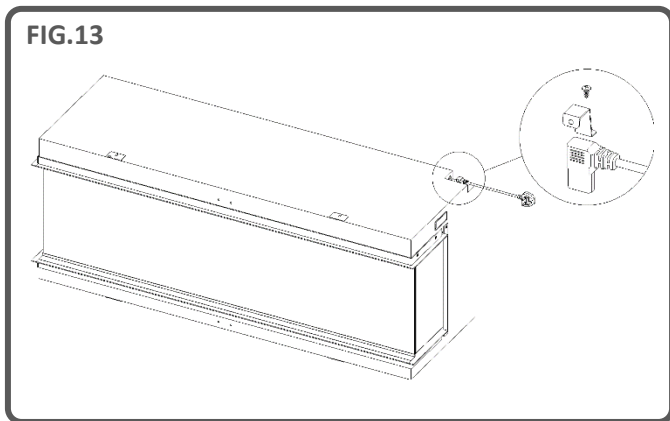

## FUEL BED SETUP

**IMPORTANT:** The logs and other fuel elements provided with the appliance must be installed in the exact locations and positions described in the steps below. Failure to install the logs correctly will result in an impaired flame effect.

All logs and fuel elements are marked with an individual code. The fuel bed is also marked with the same corresponding code and accompanying stencilled outline. Most of the logs feature a small peg on the underside that will slot into a corresponding hole on the fuel bed.



Six of the logs feature internal LED illumination. These need to be plugged into ports located on the fuel bed. **Take care not to damage the connector pins at this point as it may result in malfunction.**

Follow the sequence steps detailed below. For further assistance, scan the QR code to access a video guide.



**Step 1:** Ensure that both back panel up-lights are installed and connected. Use the thumbscrews provided to secure the lights, and ensure the cables are plugged into the connectors on the fuel bed.



**Step 2:** Position log AI-2 onto the corresponding outline on the fuel bed, locating the peg on the underside of the log into the hole in the fuel bed.



**Step 3:** Position log AI-7 onto the corresponding outline on the fuel bed, locating the peg on the underside of the log into the hole in the fuel bed.

## FUEL BED SETUP



**Step 4:** Position log AI-8 onto the corresponding outline on the fuel bed, locating the peg on the underside of the log into the hole in the fuel bed.



**Step 5:** Position log AI-1 onto the corresponding outline on the fuel bed, locating the peg on the underside of the log into the hole in the fuel bed, and plug the cable into the connector on the fuel bed.



**Step 6:** Position log AI-3 onto the corresponding outline on the fuel bed, locating the peg on the underside of the log into the hole in the fuel bed, and plug the cable into the connector on the fuel bed.



**Step 7:** Position log AI-9 onto the corresponding outline on the fuel bed, locating the peg on the underside of the log into the hole in the fuel bed, and plug the cable into the connector on the fuel bed.

## FUEL BED SETUP



**Step 8:** Position log AI-10 onto the corresponding outline on the fuel bed.



**Step 9:** Position log AI-11 onto the corresponding outline on the fuel bed.



**Step 10:** Position log AI-6 onto the corresponding outline on the fuel bed, locating the peg on the underside of the log into the hole in the fuel bed, and plug the cable into the connector on the fuel bed.



**Step 11:** Position log AA-16 onto the corresponding outline on the fuel bed.

## FUEL BED SETUP



**Step 12:** Position log P-10 onto the corresponding outline on the fuel bed.



**Step 13:** Position log AI-4 onto the corresponding outline on the fuel bed, locating the peg on the underside of the log into the hole in the fuel bed, and plug the cable into the connector on the fuel bed.



**Step 14:** Position log AI-5 onto the corresponding outline on the fuel bed and plug the cable into the connector on the fuel bed.



**Step 15:** Position log AD-8 onto the corresponding outline on the fuel bed.



## FUEL BED SETUP



**Step 16:** Position log X-14 onto the corresponding outline on the fuel bed.



**Step 17:** Distribute the clear resin embers around the base of the logs, placing them inside the clear area of the fuel bed. Ensure good coverage, including areas underneath the raised logs.



**Step 18:** Distribute the black resin embers around the base of the logs, placing them inside the black area of the fuel bed. Ensure good coverage.



**Step 19:** Distribute the black glass embers around the entire fuel bed, placing them over both clear and black resin embers. Do not feel that you need to use all of the black glass embers provided.

## FUEL BED SETUP



**Step 20:** At this stage it may be helpful to turn on the appliance to illuminate the fuel bed and review the coverage of embers.



**Step 21:** Take the remaining small logs and bark pieces and arrange them randomly around the fuel bed, Pressing them down into the embers. The small pieces of bark can be used to conceal any visible wires.



**Step 22:** Distribute the grey and black slate chips around the fuel bed. Finally, re-fit the flame screen ensuring the correct surface is forward and check for proper alignment of flames on the logs.

**IMPORTANT:** The logs and other fuel elements provided with the appliance must be installed in the exact locations and positions described in these steps. Failure to install the logs correctly will result in an impaired flame effect.

**NOTE:** When the appliance is turned on for the first time, the fuel bed will flash orange for a short time. This indicates that the appliance is warming up. The flashing will cease after approximately 10 seconds and the flame effect will activate.

For further assistance, scan the QR code to access a video guide showing how to successfully install the fuel bed.

Complete the setup by carefully re-fitting the front glass using the suckers provided, then re-fit the glass retaining bar following the steps detailed on page 8 in reverse.



## OPERATION

**IMPORTANT:** When the appliance is turned on for the first time, the fuel bed will flash orange for a short time. This indicates that the appliance is warming up. The flashing will cease after approximately 10 seconds and the flame effect will activate.

The appliance can be operated conveniently in 4 different ways: manually using controls on the appliance, via the remote control handset, via the dedicated iOS/Android app, or with voice commands using Amazon Alexa.

## MANUAL CONTROL

The manual control buttons can be located to the right side of the heater outlet – Fig 15.

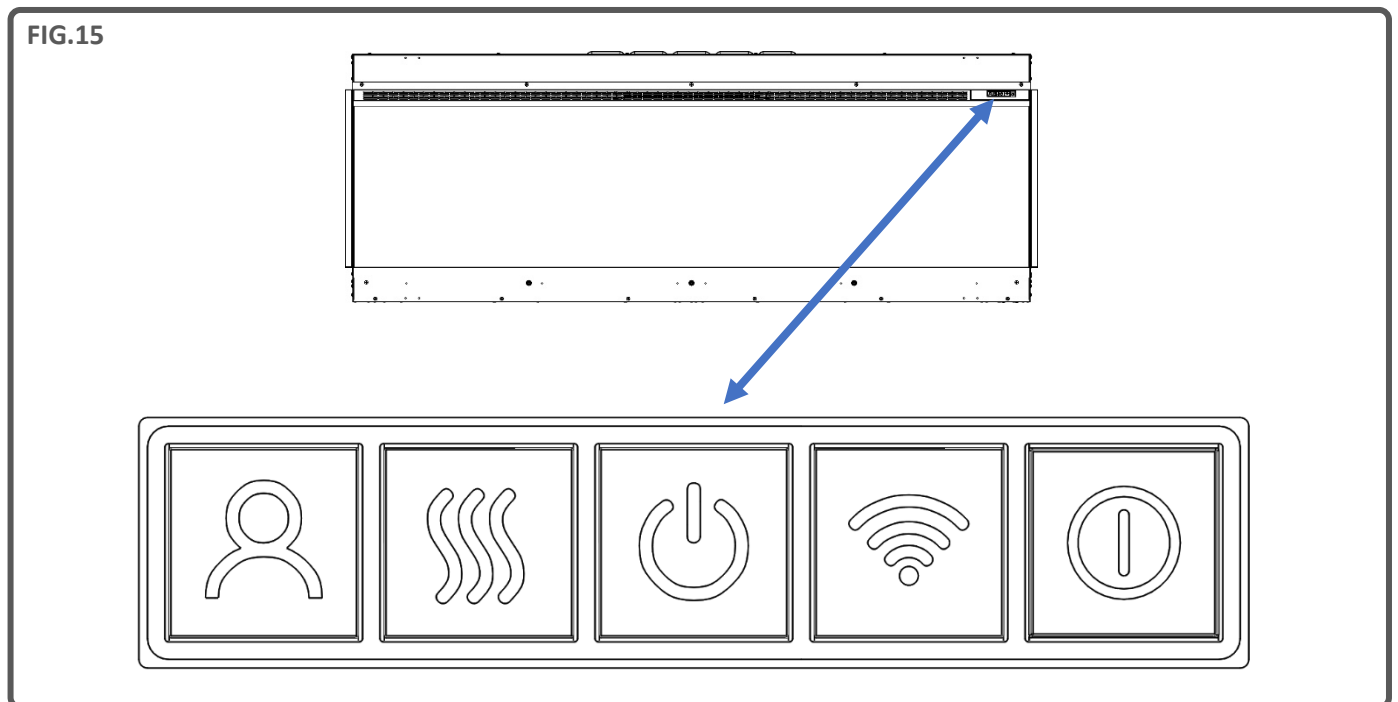

Each time a button is pressed on the appliance, remote control or app, an audible beep is emitted. To turn off this feature hold your finger on the Preset Mode button (on the appliance) for 3 Seconds.

### On/Off

Press to turn on power to the appliance. Button pushed in indicates power is on, button pushed out indicates power is off.

### Wifi On/Off

Press to turn wifi on or off. An illuminated LED on the button indicates that wifi is turned on. Hold button for 3 seconds to enter device pairing mode.

### Standby

Turns on the appliance with the last used settings without any heat. Places the appliance into standby mode with all features turned off.

### Heat Mode

1 press = cool blow. 2 press = low heat setting. 3 press = high heat setting. 4 press = no heat/no cool blow.

### Preset Mode

Press repeatedly to cycle through the 6 fire preset modes (+3 user defined presets if programmed).

# OPERATION

## REMOTE CONTROL

Ensure that 2 AAA batteries are inserted into the remote control handset. The battery power level is indicated by the column of bars to the right side of the temperature display when the appliance is in standby mode. 5 bars indicates the batteries are full, 1 bar indicates the batteries are empty and need to be replaced immediately.

### Button 1: Preset Mode

Repeatedly press to cycle through the 6 preset fire modes (+ 3 user defined presets if programmed).

On screen Pr.1 = Log Burner

On screen Pr.2 = Modern Loft

On screen Pr.3 = Lazy Glow

On screen Pr.4 = Neon Romance

On screen Pr.5 = Campfire Sparks

On screen Pr.6 = Glowing Ember

On screen Pr.7 = User Preset

On screen Pr.8 = User Preset

On screen Pr.9 = User Preset

There are 3 preset spaces allocated for the user to save personalised Electric Fire creations. Simply choose the flame colour and brightness level, the fuel bed colour and brightness level and fuel bed downlight colour and brightness level. Once you have selected your desired combination, press and hold the Preset Mode button for 3 seconds until the LCD displays Pr.7. Press – and + buttons to select a slot number between 7-9. Press and hold the Preset Mode button for 3 seconds to confirm the preset.

### Button 2: Standby

Turns on the appliance with the last used settings without any heat. Places the appliance into standby mode with all features turned off.

### Button 3&8: Minus - & Plus +

Use to navigate through different on-screen menus.

### Button 4: Flame High/Low

1 press: = Flame Low

2 press: = Flame High

### Button 5: Flame Style

Repeatedly press to cycle through flame style menu

On screen FL.0 = Flame off

On screen FL.1 = Flame type A (gas style flame), Orange

FIG.16

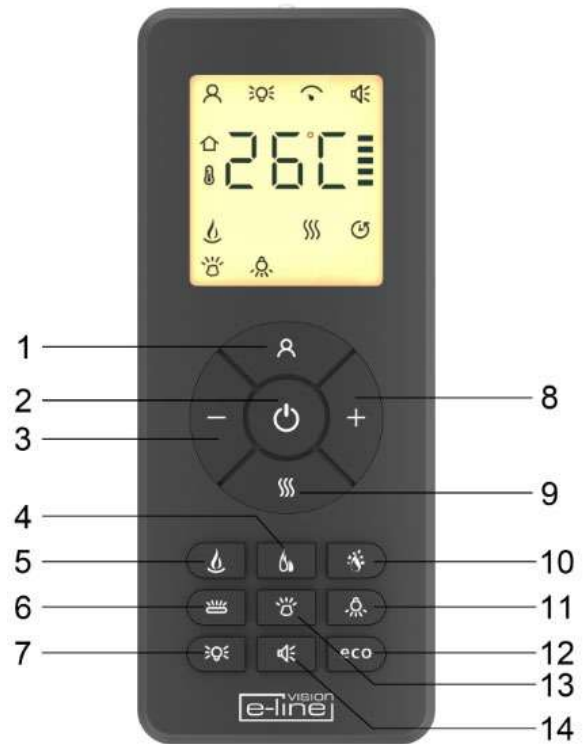

## OPERATION

On screen FL.2 = Flame type A (gas style flame), Yellow

On screen FL.3 = Flame type A (gas style flame), White

On screen FL.4 = Flame type B (wood burning style flame), Orange

### **Button 6: Log Colour**

Repeatedly press to cycle through log colour menu. Whilst in the log colour menu, press the plus and minus buttons to increase and decrease the fuel bed brightness - 1 bar is the dimmest setting, 5 bars is the brightest setting.

On screen Fb.0 = Fuel Bed off

On screen Fb.1 = Red

On screen Fb.2 = Orange

On screen Fb.3 = Yellow

On screen Fb.4 = Green

On screen Fb.5 = Light Blue

On screen Fb.6 = Dark Blue

On screen Fb.7 = Violet

On screen Fb.8 = White

On screen Fb.9 = Multi-colour auto change

### **Button 7: Ambient Lighting (if appliance is fitted with optional Ambient Lighting Kit)**

Repeatedly press to turn on ambient lighting and cycle through the different colour options.

### **Button 9: Heater Mode**

Press to cycle through the heat output options.

1 press: Co.A = Cool blow setting

2 press: H.Lo = Low heat setting

3 press: H.HI = High heat setting

4 press: no.H = No Heat (heat off / standby)

### **Button 10: Sparks**

Press to activate or deactivate the sparks and smoke feature.

1 press: = Spark on

2 press: = Spark off

### **Button 11: Fuel Bed Downlight**

Press to cycle through fuel bed down light menu. Whilst in the fuel bed down light menu, press the plus and minus buttons to increase and decrease the fuel bed brightness - 1 bar is the dimmest setting, 5 bars is the brightest setting.

## OPERATION

On screen dL.0 = Light off

On screen dL.1 = Warm white

On screen dL.2 = Cool white

### Button 12: Eco Mode

Press to activate Eco mode. This mode will reduce the brightness of all lighting modes and limit the heat output to low setting, resulting in reduced energy consumption. Press the button a second time to exit Eco mode.

### Button 13: Fuel Bed Colour

On screen Fb.0 = Fuel Bed off

On screen Fb.1 = Red

On screen Fb.2 = Orange

On screen Fb.3 = Yellow

On screen Fb.4 = Green

On screen Fb.5 = Light Blue

On screen Fb.6 = Dark Blue

On screen Fb.7 = Violet

On screen Fb.8 = White

On screen Fb.9 = Multi-colour auto change

### Button 14: Sound Effect

Press to open the open the sound effect menu.

1 press: S.on = Sound effect on

2 press: no.S = Sound effect off

Whilst in the sound effect menu, press the plus and minus buttons to increase and decrease the volume - 1 bar is the quietest setting, 5 bars is the loudest setting.

## APP CONTROL

### APP INSTALLATION AND SETUP

To connect your appliance to the Vision E-Line Solus app you will need the following:

- ✓ A device running Android or iOS such as a tablet or smart phone
- ✓ Network within range of the fire
- ✓ Valid email address, which you can access for verification

Visit your device app store (iOS or Android) to download the TUYA SMART APP. Once installed, launch the app and follow the directions to create an account. A valid email address will be required to complete the account set up process. Once your account is set up you will receive a number of permission requests - please follow the on-screen prompts.

## OPERATION

At the home screen press the **Add Device** button. Select **Small Home Appliances** from the menu.

From the list of small home appliances select **Heater (Wi-Fi)**. This will then prompt you to enter your Wi-Fi password, ensure the correct network is selected enter your Wi-Fi password then press the **Next** button.

The app will prompt you to reset the device (your iX appliance), placing it into pairing mode. Before tapping **Next** you must put your appliance into pairing mode. Ensure the appliance is switched on before commencing and press and hold the Wi-Fi button on the appliance, located on the underside of the top righthand corner, as shown below. Hold the Wi-Fi button until the fuel bed flashes red.

With the appliance in pairing mode with a flashing red fuel bed, tap the **Next** button on the app and choose the **Blink Quickly** button. The app will begin to search for the fire. When it has successfully paired the appliance fuel bed will display a solid green colour. IF the fuel bed flashes blue, this means the pairing was unsuccessful. Check your network connection and repeat the pairing process.

Upon successful pairing you can fully control your appliance and enjoy features such as programme a weekly timer that features Adaptive Start Control – a smart home device that gauges the current temperature of the room and anticipates the time required to heat it to a desired temperature. When in weekly timer mode, the appliance will automatically determine the time to turn on the heater to ensure that the set temperature is met at the time required (up to 45 minutes prior to the set time).

### APP TROUBLESHOOTING

If you have trouble connecting, check the following:

- ✓ Ensure your fire is in standby mode
- ✓ Your appliance is in range of the network
- ✓ Your smartphone/tablet is connected to your home network
- ✓ Ensure the latest version of the app is installed on your phone or tablet
- ✓ Check your network has a good signal strength

If you are still experiencing issues, please uninstall the app from your device and reinstall then repeat the above steps.

### Advanced Wi-Fi Router Guidance

Wireless transmissions get weaker as you get further from your wireless router, they can also be disrupted by general building fabrics, such as metal framework, walls & floors.

For the best possible connection to your Solus appliance, the location of your wireless router in relation to your appliance is key:

- If there are certain areas of your home where you find your signal drops, it may be due to a blockage.
- Large objects can often obstruct or interfere with a wireless connection, so it is best to keep your router off the ground and away from larger items.
- Steer clear from putting your router behind the sofa, inside a cabinet or behind a door - although it looks tidy, if you are experiencing an issue this could be the cause of the problem.
- You should also keep electronics such as microwaves, lamps, speakers, TVs and monitors as far away from the router as possible.

## OPERATION

If issues are encountered when trying to connect your appliance, our best advice would be to follow the below:

1. Check the location of the appliance in relation to the wireless router, are there any objects that may be causing a problem with the signal?
2. Check if you are experiencing the same connection problem across other devices, you can do this by checking their Wi-Fi status. Typical devices to be checked would be your mobile phone, tablet, laptop, or even your TV.
3. Try adding a new device to your wireless network – this will verify that the wireless password & SSID are correct.
4. Are you using wireless extenders? If so, turn off all wireless extenders and add try adding a new device (a mobile phone for example) in the same location as your wireless router. This confirms that your Wireless router is accepting new devices without issue.
5. You could also try resetting the wireless router.

### Tips and Advice

If the appliance is installed out of the range of your wireless network, the Wi-Fi signal will not be detected by the appliance. It may be too far away from your router. You may need to purchase a signal booster to extend the range of your home network. You can purchase a Wi Fi booster from any computer store, online or an electrical retailer.

### How do I know if my Wi-Fi signal is strong enough or if the appliance is out of range?

Simply stand in front of the appliance holding a smart device (such as a phone or tablet) that is already connected to your home router, in close proximity to the control panel – you will find the control panel on the front of the appliance to the right side of the heater outlet. Check the Wi-Fi indicator on the smart device to determine the signal strength. If the signal strength is not full, it may indicate a connectivity issue. If they are greyed out or only 1 or 2 bars are showing, then the signal strength of your home network may need boosting in order for your Tuya app to control the appliance.

## VOICE CONTROL

An Amazon Alexa or Google Assistant smart device is required to utilise the voice control system. After setting up your iX appliance with the Tuya app, connect it to your chosen smart device as follows:

In the Tuya app, select your appliance which will take you to the Vision Trimline home page (stating 'Living Room' and showing the circular temperature dial). Tap the **Settings** icon (depicted by a pen and lines) in the top right hand corner of the screen. Next, tap '**Third-party Control**' and choose either **Alexa** or **Google Assistant**. Finally, click either '**Link to Amazon Alexa**' or '**Link to Google Assistant**' and follow the on-screen instructions to complete the pairing setup.

Once paired, the following voice commands can be used:

Note: <my fireplace> refers to the name set for the iX appliance within the smart device settings. This can be changed to suit your preference.

Google Device	
Function	Command
Fireplace On/Off	OK Google, turn on <my fireplace> OK Google, turn off <my fireplace>
Flame On/Off	OK Google, turn on flame on <my fireplace> OK Google, turn off flame on <my fireplace>



## OPERATION

Google Device	
Function	Command
Flame Mode Auto/Manual	OK Google, set flame mode on <my fireplace> to auto OK Google, set flame mode on <my fireplace> to manual
Heater On/Off	OK Google, turn on heater on <my fireplace> OK Google, turn off heater on <my fireplace>
Heater Auto/Low/High	OK Google, set heat mode on <my fireplace> to auto OK Google, set heat mode on <my fireplace> to low OK Google, set heat mode on <my fireplace> to high
My Flame Preset	OK Google, set my favourite flame on <my fireplace> to 1 (or 2 - 9)
Flame Colour	OK Google, set flame colour on <my fireplace> to 1 (or 2, 3, 4) OK Google, set flame colour on <my fireplace> to off
Flame Height	OK Google, set flame height on <my fireplace> to low OK Google, set flame height on <my fireplace> to high
Sparks On/Off	OK Google, turn on sparks on <my fireplace> OK Google, turn off sparks on <my fireplace>
Fuel Bed Colour	OK Google, set fuel bed colour on <my fireplace> to 1 (or 2 - 9) OK Google, set fuel bed colour on <my fireplace> to off
Glowing Logs Colour	OK Google, set glowing logs colour on <my fireplace> to 1 (or 2 - 9) OK Google, set glowing logs colour on <my fireplace> to off
Down Light Colour	OK Google, set down light colour on <my fireplace> to orange OK Google, set down light colour on <my fireplace> to white OK Google, set down light colour on <my fireplace> to off
Mood Light On/Off	OK Google, turn on mood light on <my fireplace> OK Google, turn off mood light on <my fireplace>
Mood Light Colour	OK Google, set mood light colour on <my fireplace> to 1 (or 2 - 14) OK Google, set mood light colour on <my fireplace> to off
Sound Effect On/Off	OK Google, turn on sound on <my fireplace> OK Google, turn off sound on <my fireplace>
Volume	OK Google, mute <my fireplace>
Timer	OK Google, set timer on <my fireplace> to 30 minutes (or half an hour, 1 hour, 2 hours, etc) OK Google, cancel timer on <my fireplace>
Set Room Temperature	OK Google, set <my fireplace> temperature to N Celsius (N=5-40) OK Google, set <my fireplace> temperature to N Fahrenheit (N=41-104)

## OPERATION

Alexa Device	
Function	Command
Fireplace On/Off	Alexa, turn on <my fireplace> Alexa, turn off <my fireplace>
Flame On/Off	Alexa, turn on flame on <my fireplace> Alexa, turn off flame on <my fireplace>
Flame Mode Auto/Manual	Alexa, set flame mode on <my fireplace> to auto Alexa, set flame mode on <my fireplace> to manual
Heater On/Off	Alexa, turn on heater on <my fireplace> Alexa, turn off heater on <my fireplace>
Heater Auto/Low/High	Alexa, set heat mode on <my fireplace> to auto Alexa, set heat mode on <my fireplace> to low Alexa, set heat mode on <my fireplace> to high
My Flame Preset	Alexa, set my favourite flame on <my fireplace> to 1 (or 2 - 9)
Flame Colour	Alexa, set flame colour on <my fireplace> to 1 (or 2, 3, 4) Alexa, set flame colour on <my fireplace> to off
Flame Height	Alexa, set flame height on <my fireplace> to low Alexa, set flame height on <my fireplace> to high
Sparks On/Off	Alexa, turn on sparks on <my fireplace> Alexa, turn off sparks on <my fireplace>
Fuel Bed Colour	Alexa, set fuel bed colour on <my fireplace> to 1 (or 2 - 9) Alexa, set fuel bed colour on <my fireplace> to off
Glowing Logs Colour	Alexa, set glowing logs colour on <my fireplace> to 1 (or 2 - 9) Alexa, set glowing logs colour on <my fireplace> to off
Down Light Colour	Alexa, set down light colour on <my fireplace> to orange Alexa, set down light colour on <my fireplace> to white Alexa, set down light colour on <my fireplace> to off
Mood Light On/Off	Alexa, turn on mood light on <my fireplace> Alexa, turn off mood light on <my fireplace>
Mood Light Colour	Alexa, set mood light colour on <my fireplace> to 1 (or 2 - 14) Alexa, set mood light colour on <my fireplace> to off
Sound Effect On/Off	Alexa, turn on sound on <my fireplace> Alexa, turn off sound on <my fireplace>
Volume	Alexa, turn up volume on <my fireplace> Alexa, turn down volume on <my fireplace>
Set Room Temperature	Alexa, set <my fireplace> to 5-104 Alexa, make it warmer in here Alexa make it cooler in here

## SOLUS AMBIENT LIGHT KIT

This appliance can be used with an LED mood lighting kit approved by Vision Fires – The Solus Ambient Light Kit (available from your retailer). Other, non-approved LED light kits must not be used as they may damage the appliance and invalidate the warranty. The Solus Ambient Light Kit must only be used when connected directly to the appliance using the pre-fitted connecting adaptor (this can be found at the top right-hand corner of the appliance by the mains plug - Fig. 17). The Solus Ambient Light Kit must not be adapted to be operated independently of the appliance, such as modifying it to run on an independent 240v supply.

The Solus Ambient Light Kit is supplied as a 3m LED strip with adhesive tape backing, a 2m extension cable (not illuminated) and a 2-way splitter which may be used to attach two separate kits to the same appliance, allowing each kit to be routed to different directions/locations.

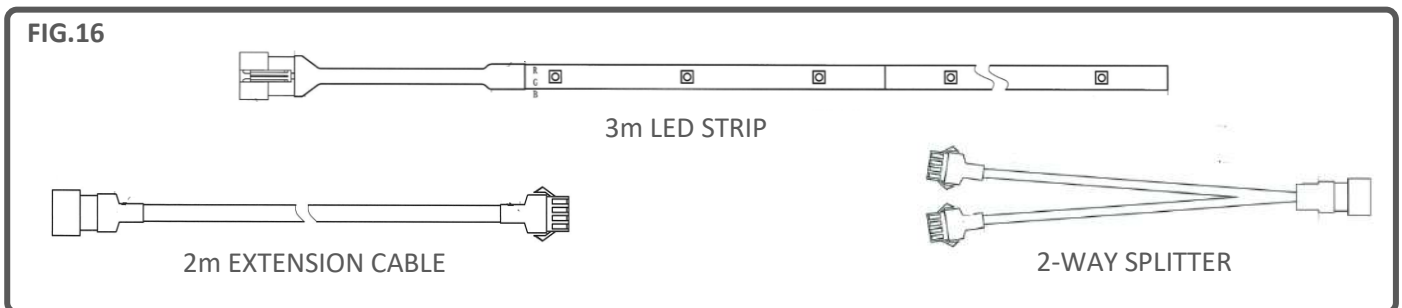
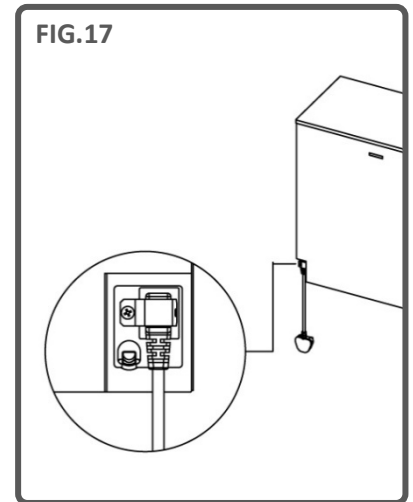

**IMPORTANT: A maximum length of 3 metres of LED strip may be used on the iX15 appliance. This may be a single strip of 3 metres, or two strips of 1.5 metres (using two Solus Ambient Light Kits and a 2-way splitter).**

**IMPORTANT: When fitting a Solus Ambient Light Kit into a Solus appliance that is built into a sealed fireplace (such as a media wall), the kit must be fitted to the appliance during the initial build stage. The Solus Ambient Light Kit is not a retrofit option as the connecting adaptor on the appliance is often not accessible after installation in these installation types.**

Typically in such installations, the kit will be connected when the appliance is placed onto the wooden purpose built base. The appliance should then be fixed to the wall or framework at that point, ready for the remainder of the installation to be constructed around it to form the completed design. The LED strip can then be routed to its designated area, with care not to damage the strip or cable during the process. Damage can occur if the strip or cable is stretched or snagged on part of the structure/installation. If the cable is damaged at the point of the appliance, it may need to be replaced completely and this would not fall within the scope of the warranty. It is best practice to test that the Solus Ambient Light Kit is working correctly before the final boarding has been fitted to the installation. Once you are satisfied that the lighting is correctly working in accordance with the controls on the remote control, the final boarding or enclosure can take place and the installation can be finished.

## CLEANING & MAINTENANCE

**IMPORTANT: ALWAYS DISCONNECT THE APPLIANCE FROM THE POWER SUPPLY AND ALLOW TO COOL BEFORE CLEANING.**

Any repairs or maintenance should only be carried out by a suitably qualified competent person.

The appliance should be occasionally cleaned using a dry cloth. Do not use detergents, abrasive cleaners or furniture polish.

To clean the glass, use a lightly damp cloth and ensure any moisture is dried fully using a lint free cloth.

Ensure that the heater vent is kept dust free by occasionally vacuuming the area using a brush attachment.

## TROUBLESHOOTING

### Resetting the Thermal Cut Out

The appliance is fitted with an Electronic Safety Control (E.S.C.). This is a safety device which switches off the fire if, for any reason, the appliance overheats, e.g. when covered. If the heater stops operating while the flame effect continues working normally, this indicates that the E.S.C. is in operation. The E.S.C. can only be reset after the appliance has cooled down and the appliance has been reset. Re-setting of the E.S.C. procedure is as follows:

1. Switch off the appliance (Manual On/Off switch) and leave it off for approximately 10-15 minutes.
2. Remove any obstruction to the fan heater outlet or fan blades etc. Make sure that the power supply is disconnected with the plug socket outlet while doing this.
3. Switch on the appliance and the E.S.C. will be reset.
4. Ensure that the appliance is functioning correctly. If the E.S. Control operates again, the appliance should be checked by a competent electrician.

PROBLEM	POSSIBLE CAUSE	SOLUTION
Appliance will not turn on.	Problem with power supply.	Check that the appliance is plugged in to the power supply and switched on.  Check and replace fuse in the plug if necessary.  Check that the main power switch on the appliance is turned on.
Remote control does not work.	Batteries have expired.	Replace batteries.
	Remote has de-synched with appliance.	Ensure that the appliance is turned on. Re-synch the remote by pressing the - button and the + button at the same time and holding for 3 seconds.
No heat	Incorrect thermostat setting.	Increase the desired temperature higher than the current room temperature.
	Overheating may have engaged the E.S.C. feature.	See above for reset procedure.
Heat turns off before desired temperature is reached.	Open window detection has activated.	Check that any windows in the room are closed.

## WARRANTY

Vision E-Line Solus appliances come with a standard 1-year warranty (parts & labour) when purchased through an authorised dealer. This can be extended for free to two years (parts only for year 2) by registering your appliance within 60 days of purchase.

Visit [www.visionfires.co.uk/warranty](http://www.visionfires.co.uk/warranty) to register your appliance, activate the free warranty extension, or to see details about the 6 year Premium Protect warranty package.







[www.visionfires.co.uk](http://www.visionfires.co.uk)



Electrical appliances should not be disposed as household waste. Separate collection facilities should be used in the disposal of electrical appliances. Contact your local government for information about the available collection systems. If electrical appliances are disposed of in landfills or dumps, hazardous substances can leak into the groundwater and get into the food chain, damaging your health and well-being.



This fire complies with the Safety Standards EN 60335-1 and EN60335-2-30 which covers the essential requirements of the Low Voltage Directive 2014/35/EU and the EMC standards EN55014-1; EN55014-2; EN61000-3-2 and EN61000-3-3 which covers the essential requirements of the European Electro Magnetic Compatibility 2014/30/EU, and the RED standards EN300220-2, EN30148 9-1, EN301489-3 and EN6247 which covers the essential requirements of the European Radio Equipment Directive 2014/53/EU.



This fire complies with the Safety Standards BS 60335-1 and BS 60335-2-30 which covers the essential requirements of the Electrical Equipment (Safety) Regulations 2016 (S.I.2016/1101) and the EMC standards BS 55014-1; BS 55014-2; BS 61000-3-2 and BS 61000-3-3 which covers the essential requirements of the Electro Magnetic Compatibility Regulations 2016 (S.I.2016/1091).and the RED standards BS300220-2, BS301489-1,BS301489-3 and Bs6247 which covers the essential requirements of the European Radio Equipment Regulations 2017.