

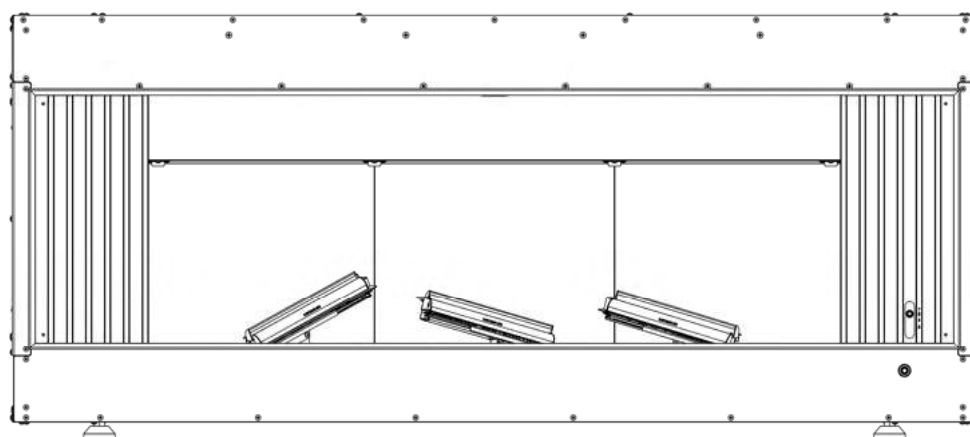

RAVEL 1500 & 1720 MEDIA WALL BF ROOM SEALED GAS LOG FIRE



USER INSTRUCTIONS INSTALLATION INSTRUCTIONS SERVICE INSTRUCTIONS

Do not use this appliance if the front glass panel is broken, removed or fitted incorrectly.

This product is designed to be installed into a false chimney breast or wall to create a media wall feature in the home.

It is a regulation that these instructions be handed to the customer after installation is complete. It is also the responsibility of the installation engineer to ensure that the customer is able to fully operate the appliance and is aware of any cleaning or maintenance requirements.

Model number: F-171XX2 SLIDE For use on Natural Gas (G20) at a supply pressure of 20 mbar in GB/IE



**THIS INSTRUCTION MANUAL MUST BE LEFT
WITH THE CUSTOMER AFTER INSTALLATION**

USER INSTRUCTIONS	1.0	Appliance Commissioning Check List	3
	2.0	User Instructions—Important information & Warnings	4
	2.1	User Instructions—Controls & Operation	5
	2.2	User Instructions—General Maintenance & Cleaning	6
	2.3	Log Layout Instructions	9
	2.4	Running in and Troubleshooting	14
INSTALLATION INSTRUCTIONS	3.0	Unpacking the appliance	15
	3.1	Regulatory Information	16
	3.2	Efficiency and Appliance Technical Information	16
	3.3	Installation Requirements	16
	3.4.0	Flue Terminal Location	17
	3.4.1	Siting the Appliance	18
	3.4.2	Appliance Dimensions (1500)	18
	3.4.3	Appliance Dimensions (1720)	19
	3.4.4	Clearance from combustibles (Installation).....	19
	3.5	Ventilation Requirements	19
	3.6	Gas Supply	19
	3.7	Unpacking the Appliance	20
	3.8.0	Trim Removal	21
	3.8.1	Glass Door Removal	21
	3.9	Preparing the Appliance for Installation	22
	4.1.1	Horizontal Flue Pipes	23
	4.1.2	Preparing the Flue Terminal	24
	4.1.3	Fit Terminal Basket	27
	4.2.1	Installation into Metal Studding	29
	4.2.2	Metal Studding—Clamp the Appliance	30
4.3	Connecting the Gas Supply	31	
4.4	Log Layout Instructions	33	
4.5.1	Refit Glass Door.....	37	
4.5.2	Refit the Trim Panel	37	
4.6.1	Controls	39	
4.6.2	Lighting the Appliance	39	
4.7	Complete the Installation	40	
SERVICING INSTRUCTIONS	5.0	Servicing the Appliance	41
	5.1	Removal the Thermocouple / Pilot	41
	5.2	Removal of the Slide Gas Valve	44
	5.3	Removal of Tee Valve	45
	5.4	Removal of Burner Injectors	46
	5.5	Removal of the Side & Rear Glass Panels	47
	6.0	Record of Annual Services	48
	7.0	Product Fiche	49
8.0	Manufacturers Instructions and User Replaceable Spares	52	

Welcome

2.0 Congratulations on the purchase of your new Wildfire Ravel 1500/1720 Media Wall gas fire. Ensure you keep these instructions in a safe place as they will be required for installation, service and general upkeep of your appliance.

These instructions should be followed precisely to ensure that you receive many years of trouble free service from your appliance.

Some general maintenance is required by the user to keep the appliance in its best condition, these are detailed later in this instructions manual.

Important

This gas appliance **MUST** be installed by a GAS SAFE registered installer by law. It must be installed in accordance to these installation instructions and the GAS SAFETY (Installation & Use) REGULATIONS 1998 as amended. Non compliance of this law may lead to prosecution and it is in the interest of you and your family that this condition is observed. Check with your gas installer that they have current membership to Gas Safe and that their membership includes gas fires.

It is very important that you also have your gas appliance serviced annually by a Gas Safe registered engineer. During this service the engineer will check the operation and performance of the appliance and also for any debris that may have collected behind the appliance. This is important for you and your families safety

Check for the Gas Safe logo on your gas engineers membership card.



Warnings

Do not place soft wall coverings (i.e. embossed papers etc,) furniture or other combustible items too close to the fires as they may discolour or scorch.

Do not place or throw rubbish or otherwise on the fuel-bed.

Do not place any combustible materials or flooring (i.e. carpets etc,) on any part of the hearth.

Many parts of this appliance and some surrounding areas will be come hot during use. All exposed surfaces, with the exception of the slide control lever ae classed as working surfaces.

This appliance has a naked flame and as with all heating appliances a fireguard should be used for the protection of children, the elderly and infirm. The fireguard should conform to BS8423 : 2002 (Fireguards or use with Gas Heating Appliances).

It is quite normal for a flame effect gas appliance to experience a small amount of soot or staining to some parts of the fuel effect components. If this becomes excessive it may be because the fuel bed is not fitted correctly — this should be checked according to these installation instructions prior to contacting a service engineer.

NEVER place any rubbish or otherwise onto the fire—this will affect the way the product operates and may affect the warranty of the product.

NEVER place more ceramic components onto the fuel bed than specified in the instructions.

Ventilation

No purpose made ventilation is normally required for this appliance when installed in G.B. Ventilation areas (if applicable) should be checked periodically to ensure there is no obstruction, even though none is normally required for this appliance.

Controls

2.1 This appliance has a concealed slide control knob. It is discreetly concealed in the grill on the right hand side of the appliance. Simply press the knob and it will protrude from its current position to enable operation.

The knob will slide up and down, this movement controls all functionality of the appliance, from ignition, flame control and turning the appliance off. When the desired operation is complete, simply press the knob inwards and it will return to its stowed position.

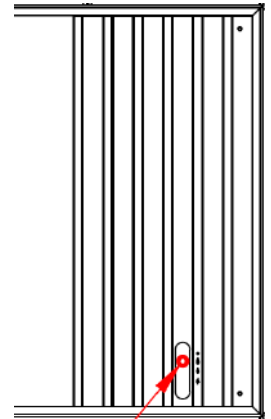

Lighting

2.1.1 Slide the control knob down to the ignition symbol. After a few seconds the pilot light should light.

If the pilot light does not light, release the control knob and wait for 3 minutes before reattempting. If the pilot does not light after 3 attempts,

Check the battery—see page 6 and also check that the ember wire is not sitting near the pilot causing a short circuit.

If the battery is new and the pilot still fails to light, contact a gas safe engineer.

Once the pilot is lit, keep the lever pushed down for up to 10 seconds then release. The pilot should stay lit and the central and front log burners will now light.

The appliance is now running at the LOW setting.

Slide the knob slowly upwards to turn the rear log burners on. The appliance is now running at the HIGH setting.

To turn the fire off, slide the lever all the way to the top to the OFF symbol.

Should the spark generator fail to provide a spark at the electrode it may be that a small amount of soot or ember wire has fallen from the fuel bed onto the pilot assembly, causing a short circuit. If this is the case, ensuring the appliance is off and cold, this area can be cleared. See page 6 for details on glass removal to access this area.

Alternatively check the battery is in good condition—see page 6 for details.



USER INSTRUCTIONS

WILDFIRE
SPREADING INNOVATION

Trim

2.2 To remove the trim, use the hexagonal Allen key tool (supplied) to loosen the four small screws in each corner of the trim. These screws do not come free from the appliance, they remain attached to the trim assembly.

If the trim is removed, always ensure it is stored somewhere safe where it cannot be damaged.

To refit the trim/grill assembly (**taking note of details on pages 37 & 38 regarding trim guides**) tighten the four corner screws.

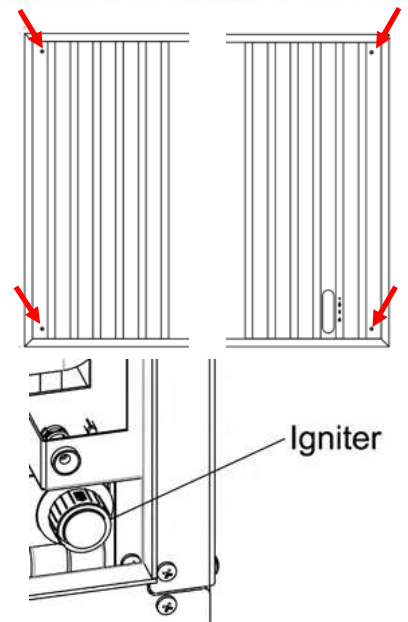

Battery

2.2.1 This gas appliance uses a single AA type battery which supplies the power for the spark generator used during the ignition process. The battery box which houses this battery is located behind the trim /grill assembly. See above instruction for trim removal details. Unscrew the plastic cap and replace the battery ensuring correct polarity.

Refit the trim/grill assembly and tighten the four corner screws.

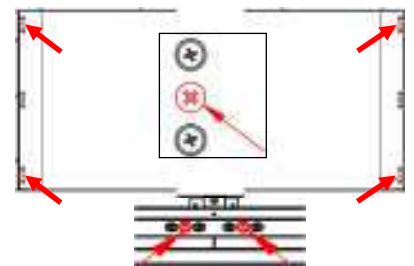

Glass door

2.2.2 To remove the glass door the trim must first be removed—see details above.

8 screws hold the glass door in place, 3 vertically on each side and 2 on the bottom. Remove the 4 screws from each corner and the 2 screws from the bottom first.

Attach and push the 2 suction cups (supplied) to the 2 sides of the glass panel and pull the lever to engage the suction. It is recommended that the suction cups be placed at mid height and approximately 500mm apart. To give best manoeuvrability.

Whilst supporting the glass panel with the suction cup handles, remove the last two central screws.

Using the suction cup handles, carefully rotate the glass door lower edge out towards you, keeping this bottom edge within the appliance housing — see diagram.

Now lower the glass door downward inside the housing

Finally, tilt the top edge of the glass door out towards you then it can be removed from the appliance.

Store the glass door where it cannot be damaged.

Never run the appliance with a damaged or broken glass panel

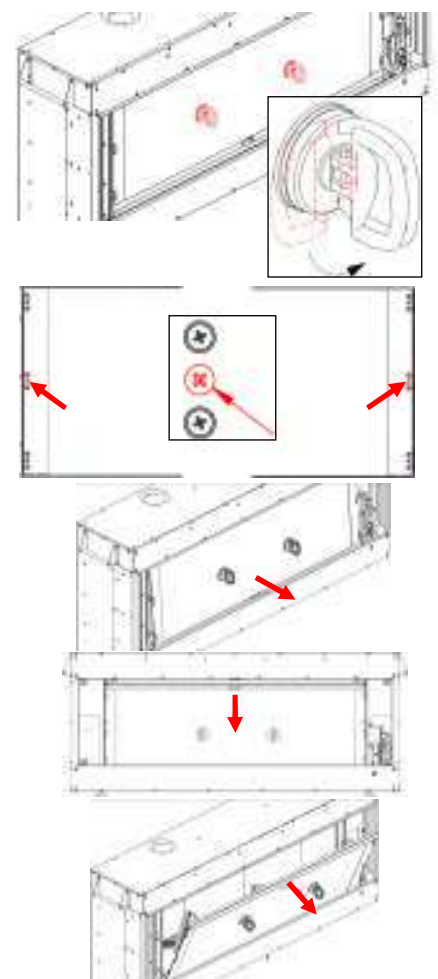

Cleaning

Cleaning is recommended for some parts of this appliance. The glass can be cleaned with a non abrasive glass cleaner and lint free cloth. See page 6 for glass removal details to enable the inside glass face to be cleaned. The glass panel will, over time, experience condensation marks and is normal for all glass fronted gas appliances. Metal parts can be cleaned with a lint free damp cloth.

Fuel Bed

HEALTH AND SAFETY NOTICE

This appliance uses fuel effect pieces manufactured from Refractory Ceramic Fibres (RCF). Care must be taken to avoid excessive exposure to these materials as they may cause irritation to the eyes, skin, nose and throat. When Handling avoid inhaling and contact with skin and eyes. It is recommended that disposable gloves are worn in addition to a facemask and eye protection. After handling wash hands thoroughly and any other exposed parts which may have come in to contact with the material.

If a vacuum cleaner is used to clean the fuel bed or areas around the appliance there fragments of the material may have fallen it is recommended that it be of the type fitted with a **HEPA** filter.

Care should be taken when disposing of RCF materials. It is important to keep any dust to a minimum so it is recommended that the fuel effect components are placed into a heavy duty plastic bag. The bag should be clearly labelled **RCF WASTE**. These materials are not classified as hazardous waste and should be disposed of at a site approved for the disposal of industrial waste.

The fuel effect components supplied with this product are extremely fragile and must be handled with great care. The ceramics in this appliance are not covered by the warranty due to their fragility. This includes the RCF fibre boards in the fire box. These components will break or chip if not handled with the greatest of care.

Cleaning of these components should only be undertaken once the appliance is switched off and has been allowed to cool for a minimum period of one hour. The components should be lifted carefully piece by piece from the appliance and placed onto a dust sheet or similar. They can be brushed gently with a soft brush to remove any dust or deposits. If you intend to use a vacuum cleaner then this should only be done once the loose deposits of soot etc have been removed. Ensure that the moulded components are structurally sound and no significant part of the moulding has broken away. If any component has broken then it should be replaced before using the appliance. Only the correct replacement part as supplied by the manufacturer shall be used in this appliance. Do not add any additional components to the fuel bed layout. It is important to note that small hairline cracks will appear in the surface of the ceramics due to heat expansion and contraction—this is perfectly normal.

See the full details of log and fuel bed installation from page 9 for removal and replacement of the ceramic log and bark components.

Pilot

It is important to ensure that no soot particulates or the ember wire come into contact with the pilot or its sub-components . This may cause problems with lighting the appliance. Check these areas before contacting the manufacturer.

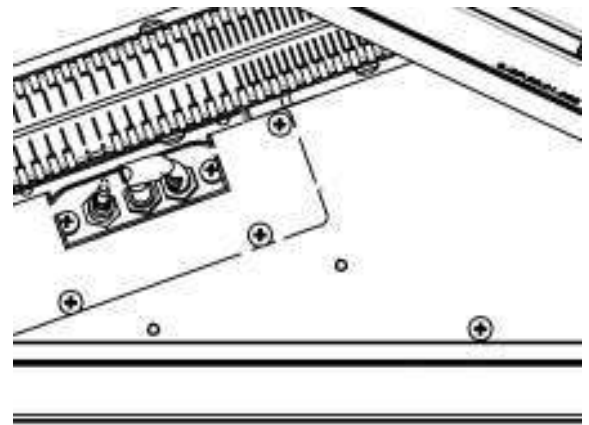

Log Setup

2.3 The following instructions detail how the ceramic fuel bed and loose components are to be installed onto the appliance. Great care should be taken when handling these ceramic parts as they are fragile and can easily be broken. Do not force any component into position, if it does not fit easily then you are not fitting the part correctly. These instructions can also be followed to remove or reinstall the fuel bed after cleaning. This is a procedure that can be undertaken by the customer as required and the frequency will be depend upon use.

See page 6 for glass door removal and installation.

The fuel bed setup involves the installation of volcanic rock, ceramic bark, ember wire and a boxed set of ceramic decorative logs. These components will have been installed by your gas engineer at the point of installation, however it is permitted for the end user to remove clean and replace these components as necessary. The following installation instructions must be adhered to at all times.

The following diagram is for identification purposes. It is imperative that the logs are placed in the correct position for safety and also to ensure that you obtain optimal performance from your appliance. If the flame picture appears to be abnormal, it may be that one or all of the three main logs has been positioned incorrectly. Ensure the correct logs are installed onto the correct burner. If popping noises are heard, this is also indicative of incorrectly placed logs or volcanic rock placed too close together.

Identify

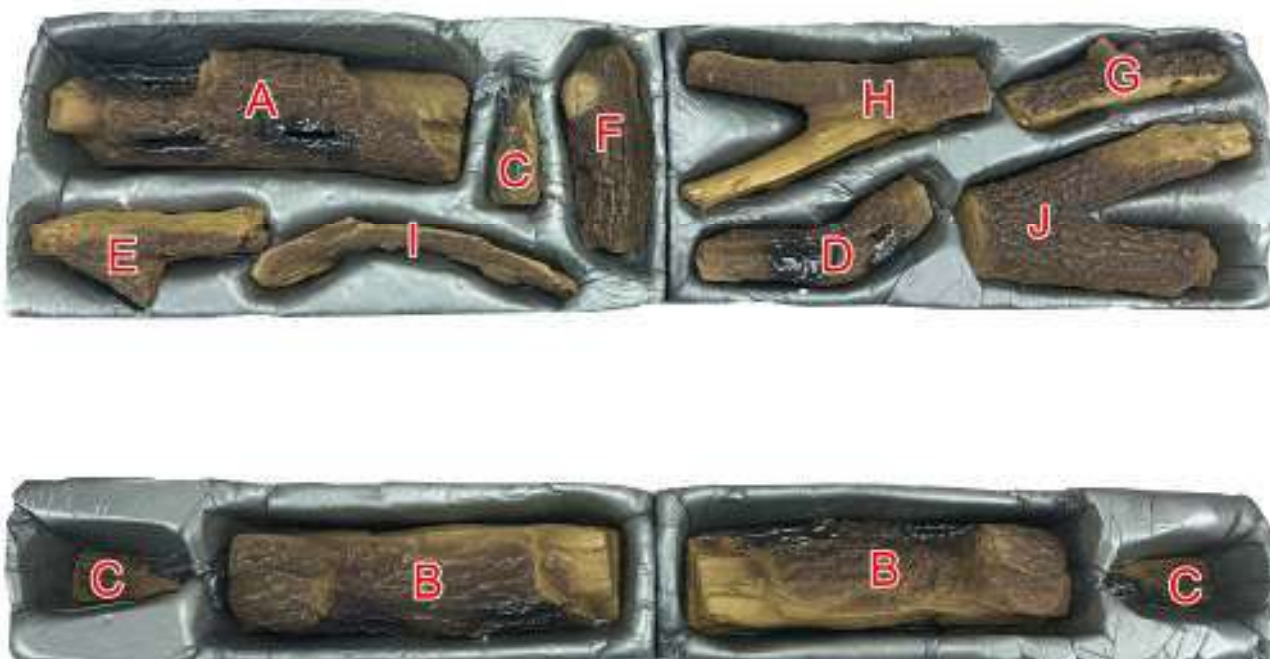

USER INSTRUCTIONS

Fuel Bed

Place the volcanic rock on top of the centre burner, which runs across the base of the fire, as shown. Ensure a 5-10 mm gap is left between each piece. Then using **half** of the glowing ember wire supplied, ruffle between fingers to make it loose, about 10mm wide and long enough to cover the visible volcanic rock then align over the rock as shown. Ensure **no wire is placed within 25mm of the pilot assembly**. Retain the other half of the wire for replacement at annual service.



Place Log A and the two Log B's as shown in the picture below.

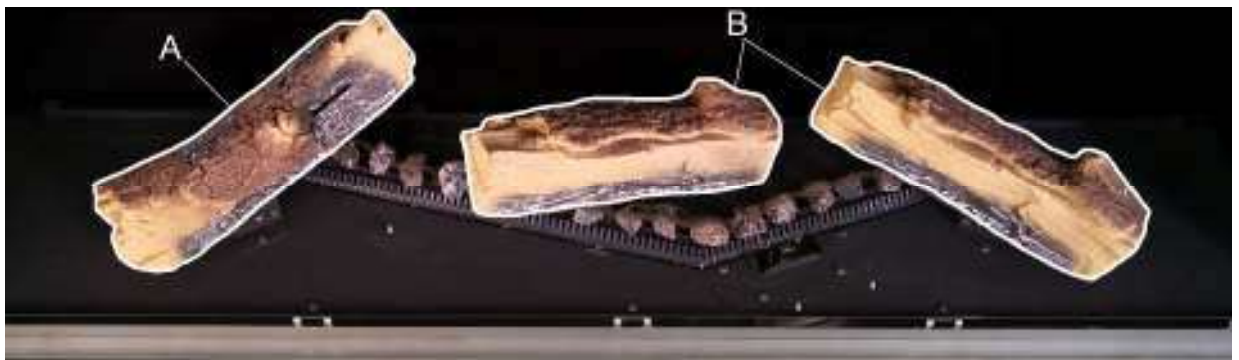

Place Log C as shown in the picture below.

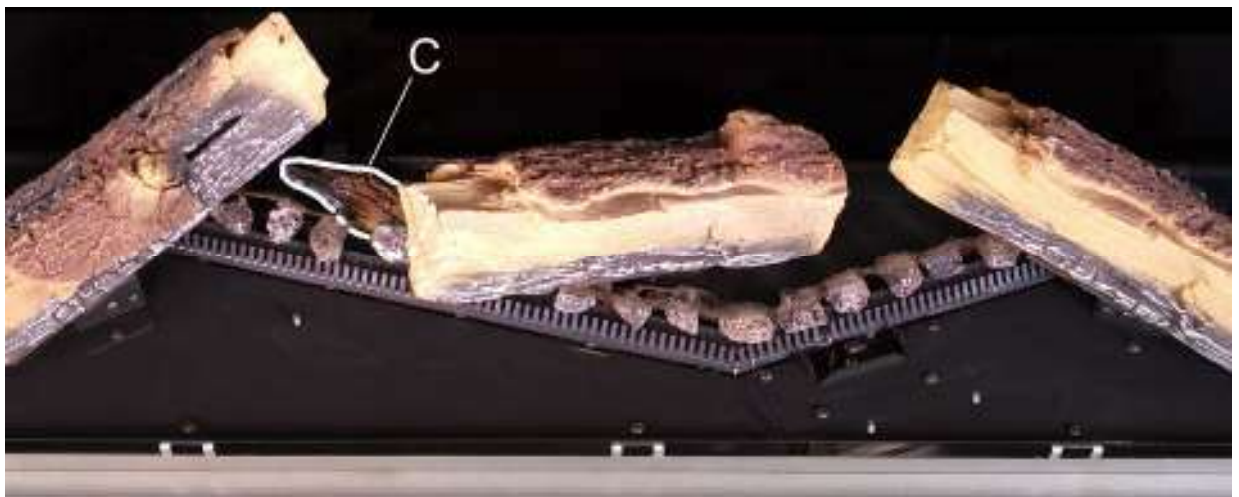

Place Log D onto the fuel bed as shown below, ensuring it fits **securely over the raised pin**.



Place Log E in the orientation shown.

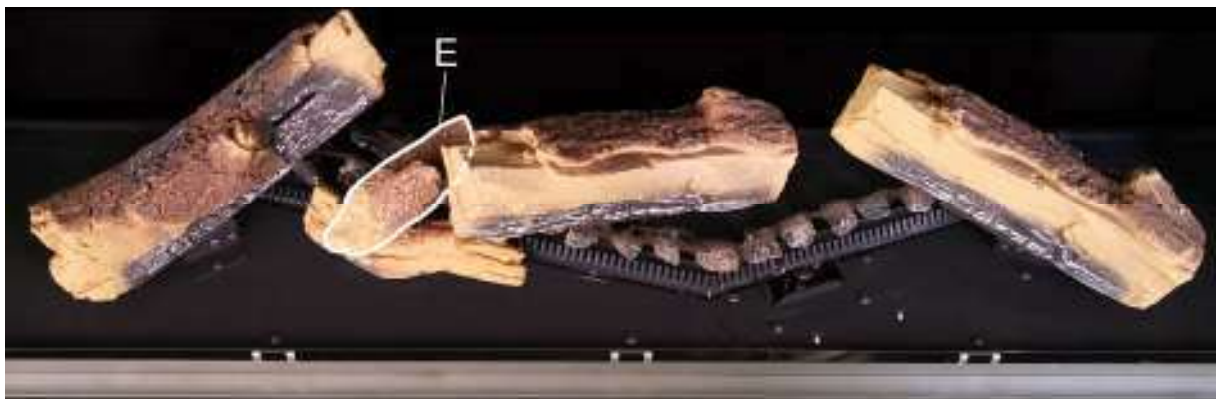

Place Log F in the orientation shown below. This log sits **securely on two pins** protruding from the fuel bed.



Sit Log G onto Log F as shown.



Place Log H against Log A as shown. Ensure the lower limb sits just in front of the air slot. Sit Log I onto the fuel bed while resting the upper portion against the small bump on Log B.



Place Log J against Log C as shown.



Place the bark around the fuel bed as shown. Ensure that no bark can interfere with the pilot operation.



Place one of the Log C's onto the burner bed as shown.



Place the other Log C onto the burner bed as shown.



Running In

2.4 When this appliance is first used it is important to note that you may experience some fumes, smells and visible smoke in the room of operation. Any fumes emitted during the first few minutes of use can be quite pungent and it is advised that a window is opened until this subsides. Smells associated with paints, oils and starch from ceramic components may last several hours but will rapidly diminish over the first few uses of the appliance.

It should be noted that as with all flame effect gas appliances, some sooting can be evident and can be cleaned away—see cleaning instructions on previous pages.

Trouble Shooting

The following table should be used to identify any problems experienced with the operating or running of your appliance prior to contacting the manufacturer or retailer regarding service.

THE FIRE WILL NOT LIGHT

Can you hear a continuous clicking during the ignition process?	YES ↓	NO Check Battery
Does the pilot light?	YES ↓	NO Check and remove soot or ember wire near the pilot
Does the pilot go out when the lever is released?	YES →	Try again, but before releasing the lever give a firm push down before releasing the lever.

THE FIRE GOES OUT

Does the fire light and run ok then subsequently turns off automatically	YES →	The thermocouple may need replacing.
--	-------	--------------------------------------

VISUAL PROBLEMS

Does the flame picture look wrong?	YES →	Check log placement as per the user instructions see pages 9-13
Does the glass have grey water marks on inside surface	YES →	The glass will require infrequent cleaning dependant on use. See page 6 to remove glass door.

Warranty



The Wildfire 5 year limited guarantee is managed directly by Hearth Products Ltd. With our experienced Gas Safe engineers and through our extensive network of service centres throughout the UK we will ensure your appliance receives the right care should anything fail prematurely. Choose Wildfire for style, performance, reliability, value and peace of mind.

Unpacking Appliance

3.0 TAKE GREAT CARE WHEN UNPACKING THE APPLIANCE SOME PARTS CAN BE EASILY DAMAGED.

Cut the straps and lift the carton from the base packing. Remove any foam packaging and ensure the instruction pack and any fitting packs are removed. Check all packaging to ensure no components are thrown out.

This appliance is very heavy. The appliance has two handles, one on each side, as shown in the diagram. These should be used to lift the appliance into its installation position. The fire weighs approximately 90kg with glass and chamber contents removed.

The **Ravel 1500 Trim/Grill** is supplied with the appliance. The **Ravel 1720 Trim/Grill** is an optional extra.

The flue and terminal kit is supplied in a separate carton. See page 20 for contents.

There will be three plastic bags also located in the main carton and one flue kit fitting pack in the terminal carton.

Note that the guarantee registration can also be performed online at: www.hearthproducts.co.uk/register-new-product/

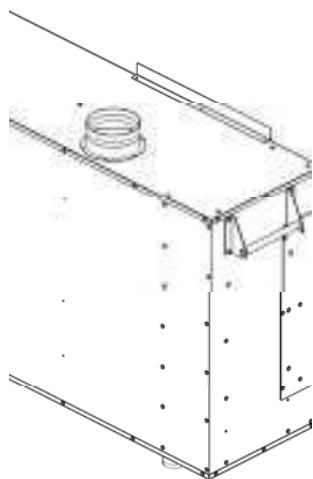

Pack 1				Pack 2				FLUE KIT FITTINGS PACK																							
Item	Picture	Description	Qty	Item	Picture	Description	Qty	Item	Picture	Description	Qty																				
1		Instruction Manual	1	1		Baffle	2	1		Aluminum tape	1																				
2		Rubber Grommet	1	2		Flange	4	2		ST3.9*6.5 Screw	8																				
3		Isolation Elbow	1	3		ST4.2*10 Screw	46	3		Wooden Wall Plug	10																				
4		Allen Driver <i>To be left with the customer after installation is complete</i>	1					4		ST5*40 Wood Screw	10																				
5		Suction Cup <i>To be left with the customer after installation is complete</i>	2	<table border="1"> <thead> <tr> <th colspan="4">Pack3</th> </tr> <tr> <th>Item</th> <th>Picture</th> <th>Description</th> <th>Qty</th> </tr> </thead> <tbody> <tr> <td>1</td> <td></td> <td>Side Convection Terminal</td> <td>2</td> </tr> <tr> <td>2</td> <td></td> <td>Convection Collar</td> <td>4</td> </tr> <tr> <td>3</td> <td></td> <td>Convection Pipe Clamp</td> <td>4</td> </tr> </tbody> </table>				Pack3				Item	Picture	Description	Qty	1		Side Convection Terminal	2	2		Convection Collar	4	3		Convection Pipe Clamp	4	5		Φ5.3*Φ15 Washer	4
Pack3																															
Item	Picture	Description	Qty																												
1		Side Convection Terminal	2																												
2		Convection Collar	4																												
3		Convection Pipe Clamp	4																												
6		Ember Wire	1																												

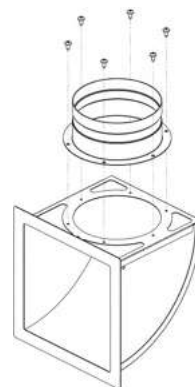

Attach the two convection collars to the side convection terminals as shown.

Regulatory Information

3.1 NOTE THE FOLLOWING PRIOR TO THE INSTALLATION OF THIS APPLIANCE.

This gas appliance **MUST** be installed by a GAS SAFE registered installer by law. It must be installed in accordance to these installation instructions and the GAS SAFETY (Installation & Use) REGULATIONS 1998 as amended. Non compliance of this law may lead to prosecution and it is in the interest of you and your family that this condition is observed.



The installation of this appliance must be in accordance with the relevant parts of the LOCAL AND NATIONAL BUILDING REGULATIONS as issued by the Department of the Environment or BUILDING STANDARD (Scotland Consolidation) REGULATIONS issued by the Scottish Development Department and the following relevant British Standards:

- BS5871** Part 2 Installation of Inset Live Fuel Effect Gas Fires
- BS5440** Parts 1 & 2 Installation of Flues and Ventilation
- BS6891** Installation of Gas Pipe-work
- IS813:1996** Domestic Gas Installation (Republic of Ireland)

If the product is being installed into a timber framed building then advice should be sought specifically as building alterations may void any cover supplied by NHBC. If in doubt contact your local building and planning authority. Further information can be obtained from the publication: Gas Installations in Timber Frame Buildings : IGE/UP/7 Edition 2.

Efficiency /Technical

3.2 The efficiency of this appliance has been tested to EN613 and the result is 75.2% net (67.7% gross). This efficiency value has been verified by Kiwa (0558). This efficiency value can be used for SAP (Standard Assessment Procedure) for energy rating of UK dwellings.



Appliance Technical Information

GAS TYPE: NATURAL	GAS CATEGORY: I _{2H}	INLET PRESSURE: (COLD)20mBar
HEAT INPUT: GROSS 9.6kW 0.9m ³ /h	INJECTORS: 1.62 (1) 0.98 (4) 1.03 (2)	DESTINATION COUNTRIES: GB / IE

Installation Requirements

3.3 Prior to installation ensure that the gas supply is compatible with the appliance, this appliance must only be used on **natural gas on a gas installation with a governed meter** at a supply pressure of 20 mbar as marked on the data plate on the appliance and the carton.

This appliance must only be installed in accordance with BS5440: Part 1 and these installation instructions.

For minimum and maximum flue dimensions refer to page 18 & 23 of these instructions. The horizontal flue section only should be modified by the installer to suit the installation, no modification should be made to the flue terminal. The guard (supplied) must be fitted to the terminal if any part of the terminal is below 2 metres above any accessible point, ie the ground or balcony etc.

Flue Terminal

3.4.0 REGULATORY REQUIREMENTS FOR FLUE TERMINAL LOCATION

THE FOLLOWING MUST BE NOTED PRIOR TO THE INSTALLATION OF THIS APPLIANCE.
NOTE: THE DIMENSIONS SHOWN APPLY TO ANY PART OF THE TERMINAL STRUCTURE.

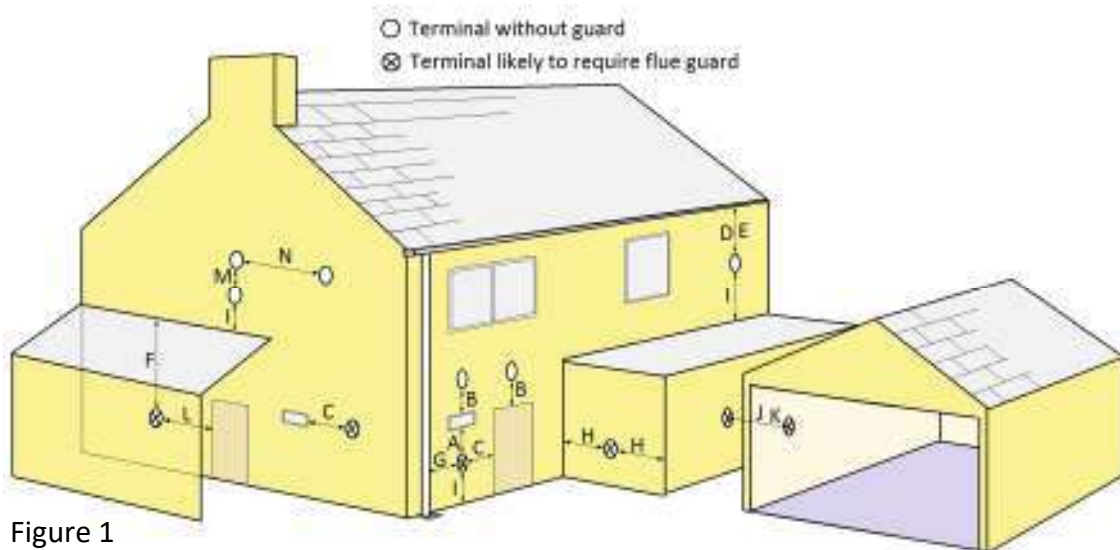

Figure 1

Key	Terminal Position	Min. Distance
A*	Directly below an opening, airbrick, opening window etc.	300mm
B*	Above an opening, air brick, opening window etc.	300mm
C*	Horizontally to an opening, air brick opening window etc.	300mm
D	Below gutters, soil pipes or drains.	300mm
E	Below eaves.	300mm
F	Below balconies or car port roof.	600mm
G	From a vertical drain pipe or soil pipe.	300mm
H**	From an internal or external corner	600mm
I	Above ground, roof, or balcony level.	300mm
J	From a surface facing the terminal.	600mm
K	From a terminal facing a terminal	600mm
L	From an opening in a car port (e.g. door, window) into dwelling.	1200mm
M	Vertically from a terminal on the same wall.	1500mm
N	Horizontally from a terminal on the same wall.	300mm

* In addition, the terminal should not be nearer than 300mm to an opening in the building fabric formed for the purpose of accommodating a built-in element such as a window frame or door frame.

** The reference to external corners does not apply to building protrusions not exceeding 450mm, such as disused chimneys on external walls.

A terminal guard is supplied with this appliance. It is a requirement in England and Wales that this a guard be fitted where the flue terminal may come into contact with people near the building or be susceptible to damage.

In the republic of Ireland the installation must conform to the relevant sections of IS813 'Domestic Gas Installations'.

Hearth Products recommend that the terminal guide be fitted in any area where it may be damaged or contact could be made with the flue terminal.

Site Requirements

3.4.1 Do not place soft wall coverings (i.e. embossed papers etc,) furniture or other combustible items too close to the appliance as they may discolour or scorch.

Do not place or throw rubbish or otherwise on the fuel-bed.

It is very important that you arrange for a GAS SAFE registered engineer to service your appliance every year – This is important for you and your families safety.

NEVER place more ceramic components onto the fuel bed than specified in the instructions.

NEVER touch the glass panel or metal parts surrounding the glass when the fire is running or if it has recently been in operation—these components retain heat and may cause burns. Leave the appliance to sufficiently cool prior to any contact.

WARNING: This appliance has very hot surfaces when in use and as with all heating appliances a fireguard should be used for the protection of children, the elderly, infirm and pets. The fireguard should conform to BS8423 : 2002 (Fireguards or use with Gas Heating Appliances).

Hearth

No hearth is required for this appliance. See Clearances from combustibles **3.4.4**

Appliance Dimensions

3.4.2 See diagrams below for appliance dimensions. Note these dimensions apply to the 1500 model. For 1720 model see **3.4.3**

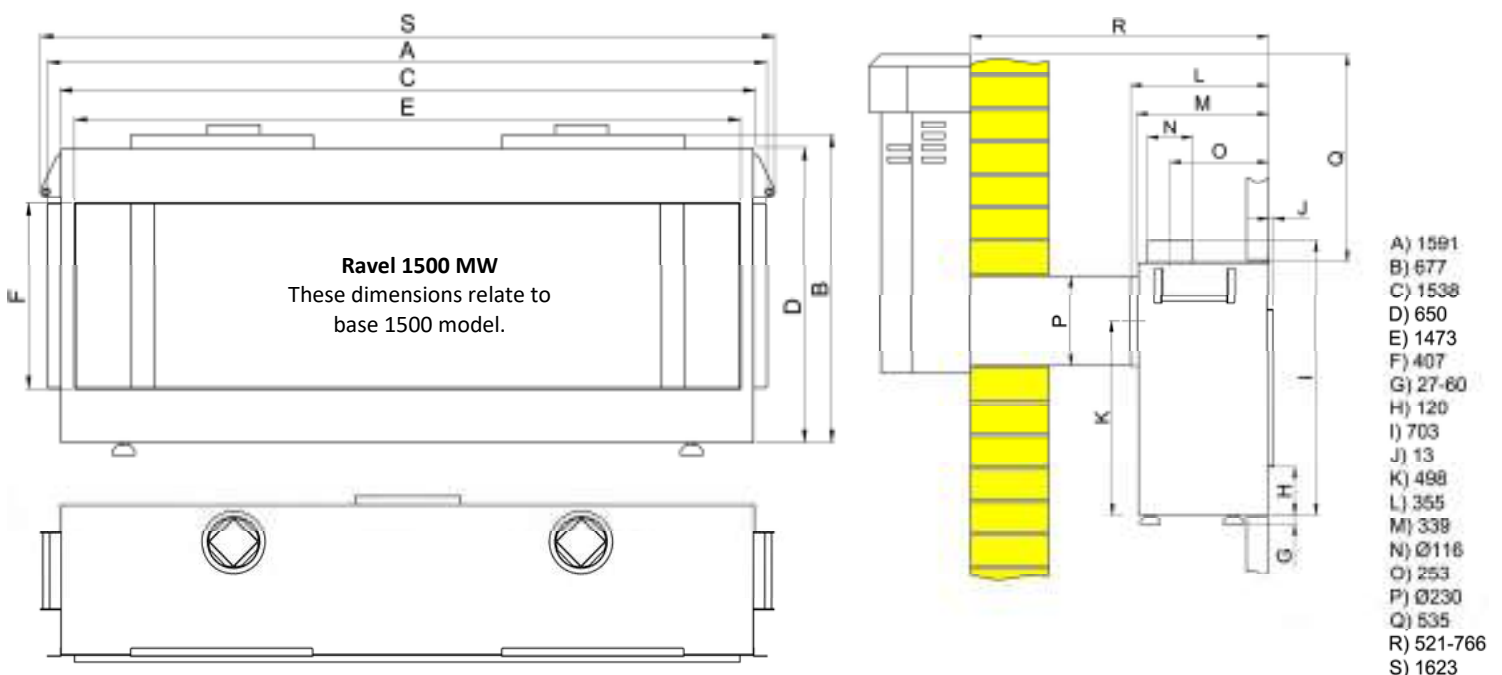

Appliance Dimensions

3.4.3 See diagrams below for the 1720 appliance dimensions. Note these dimensions require the installation of the 1720 kit (Supplied separately).

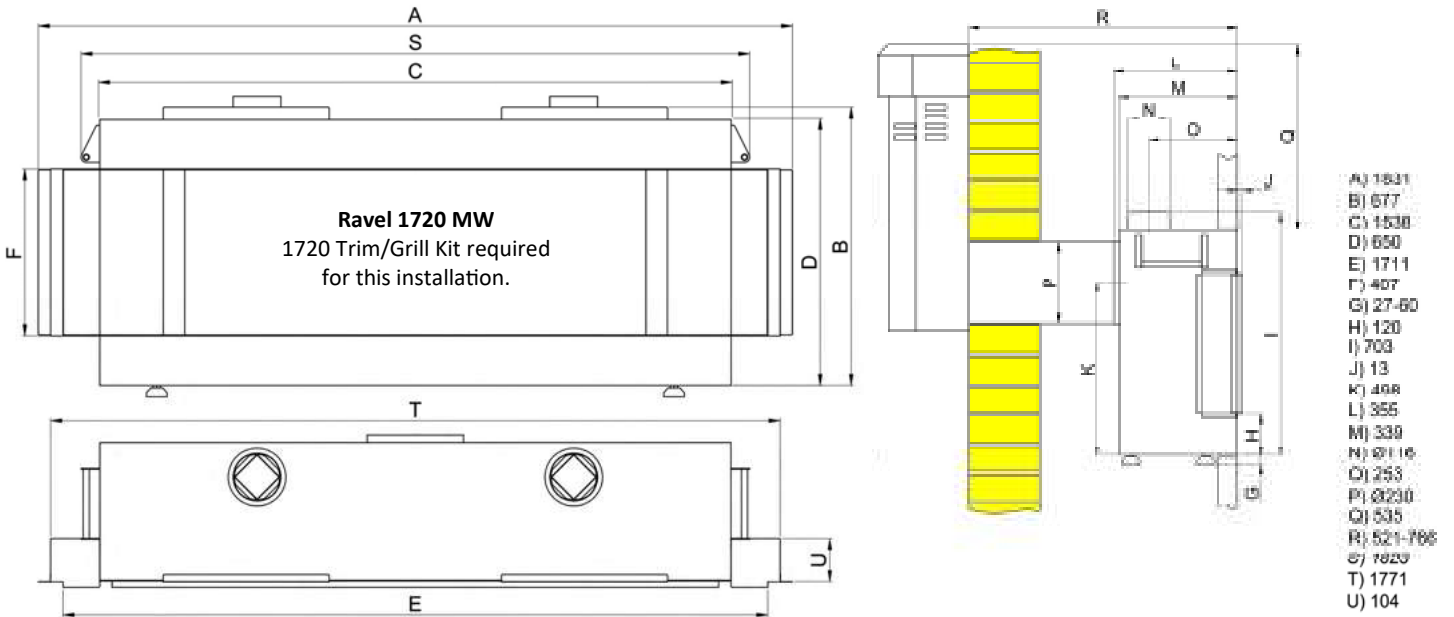

Combustibles

3.4.4 The following diagram shows the area which must be clear of all combustible materials.

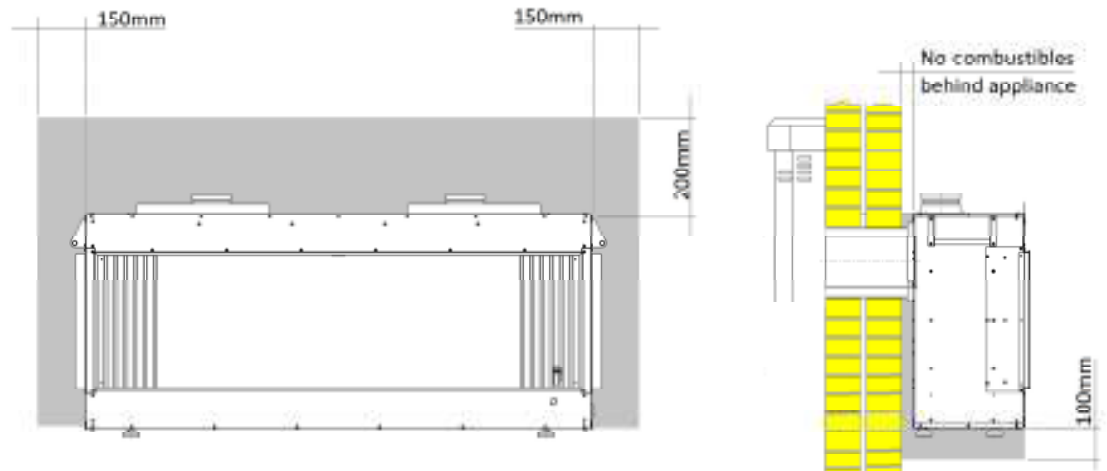

It is recommended that a space of 10mm is left between the back of the appliance and wall. If this is not possible, it is recommended that the plasterboard in this area be removed to provide this clearance.

Ventilation

3.5 No purpose made ventilation is required for this product as it is room sealed. Always check the current rules in force for the country of installation.

Gas Supply

3.6 This appliance is suitable for use on natural gas (G20) only from a governed meter. It is the responsibility of the installer to ensure that correct pipe sizing has been supplied to the site for correct performance. 8mm diameter ductile copper tubing should be used for the run to the appliance at a maximum length of 500mm to avoid pressure drops. The appliance is supplied with a isolation device which must be used as part of the installation. There should be no soldered joints within the firebox of the appliance.

Unpacking the
Appliance

- 3.7** All **ceramic components** and the **two side convection outlets** are shipped within the appliance. These items should be removed and stored in a place where damage cannot occur. The trim and glass door will have to be removed to access these components. See next page for details on their removal.

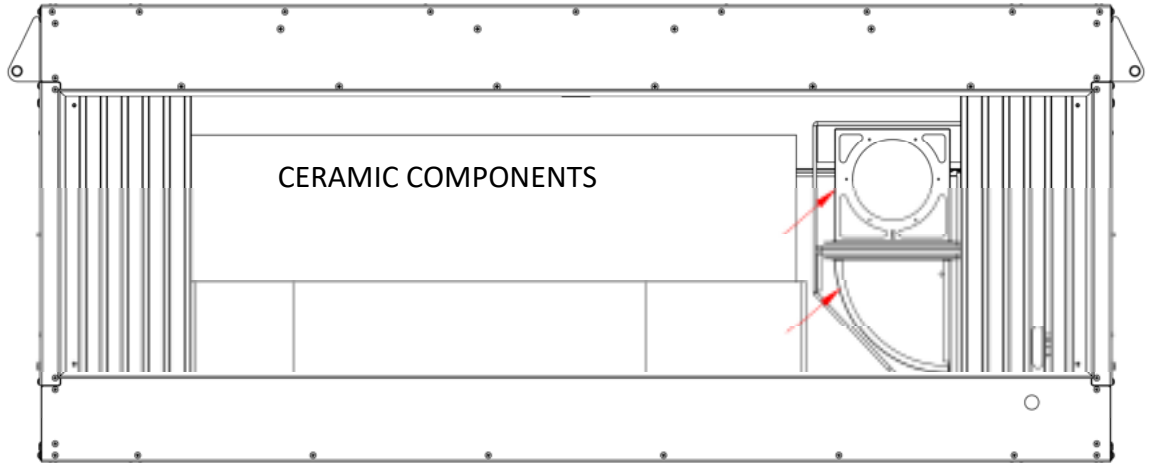

The flue and terminal kit is shipped in a separate carton. **The flexible/extendible convection tubes are contained within the flue pipe and terminal.**

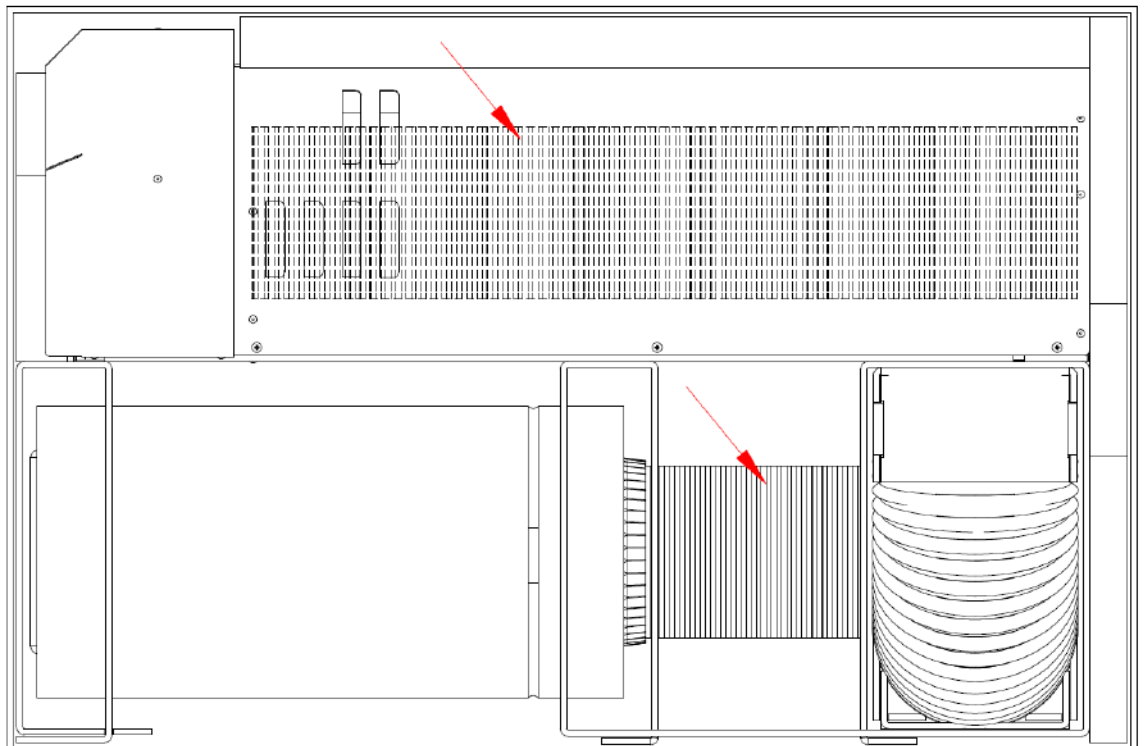

Trim

3.8.0 To remove the trim, use the hexagonal Allen key tool (supplied) to loosen the four small screws in each corner of the trim. These screws do not come free from the appliance, they remain attached to the trim assembly.

If the trim is removed, always ensure it is stored somewhere safe where it cannot be damaged.

To refit the trim/grill assembly and tighten the four corner screws.

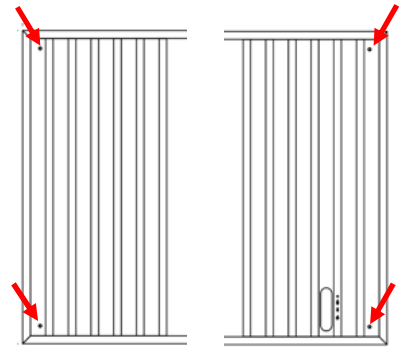

Glass door

3.8.1 To remove the glass door the trim must first be removed—see details above.

8 screws hold the glass door in place, 3 vertically on each side and 2 on the bottom. Remove the 4 screws from each corner and the 2 screws from the bottom first.

Attach and push the 2 suction cups (supplied) to the 2 sides of the glass panel and pull the lever to engage the suction. It is recommended that the suction cups be placed at mid height and approximately 500mm apart. To give best manoeuvrability.

Whilst supporting the glass panel with the suction cup handles, remove the last two central screws.

Using the suction cup handles, carefully rotate the glass door lower edge out towards you, keeping this bottom edge within the appliance housing — see diagram.

Now lower the glass door downward within the housing to clear the top locating slot.

Finally, tilt the top edge of the glass door out towards you then it can be removed from the appliance.

Store the glass door where it cannot be damaged.

Never run the appliance with a damaged or broken glass panel

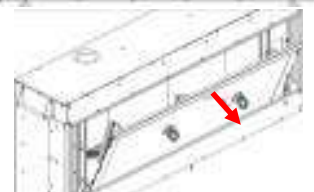
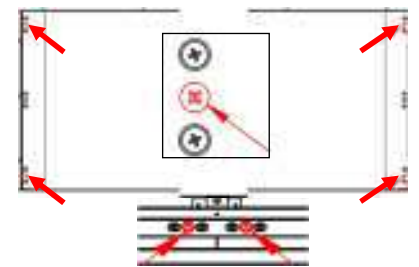

Now remove all components carefully from the chamber.

Adjust Feet

3.9 The appliance has 4 adjustable feet which can be rotated to increase or decrease the height of the appliance. These feet should also be used to ensure the appliance is level in all directions. Do not proceed with the installation until the appliance is sited correctly.

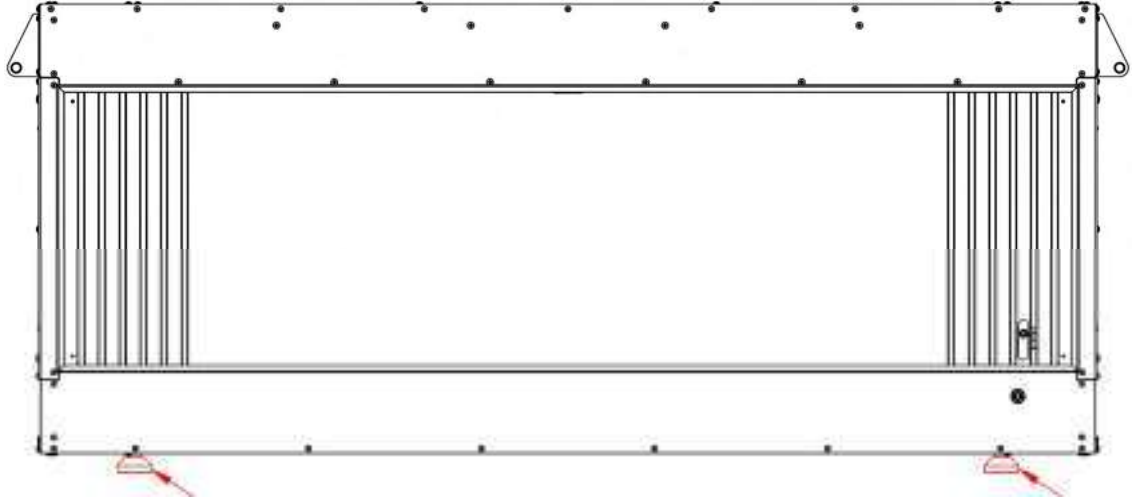

Cooling Baffles

Fold the two cooling baffles as shown to create a square structure.

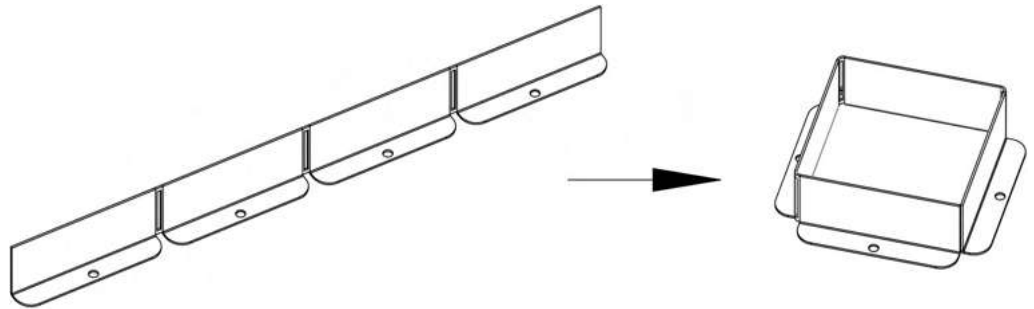

Fit Baffles, Collars & Flanges

Now fit the two baffles and the two collars to the convection outlets as shown in the diagram below. Finally fit the four flanges to the appliance. Two flanges at the top, and one on each side. Note: if the appliance is being installed as a 1720 model, the side flanges should be installed later, after the convection extension boxes have been fitted—See the 1720 trim installation instructions.

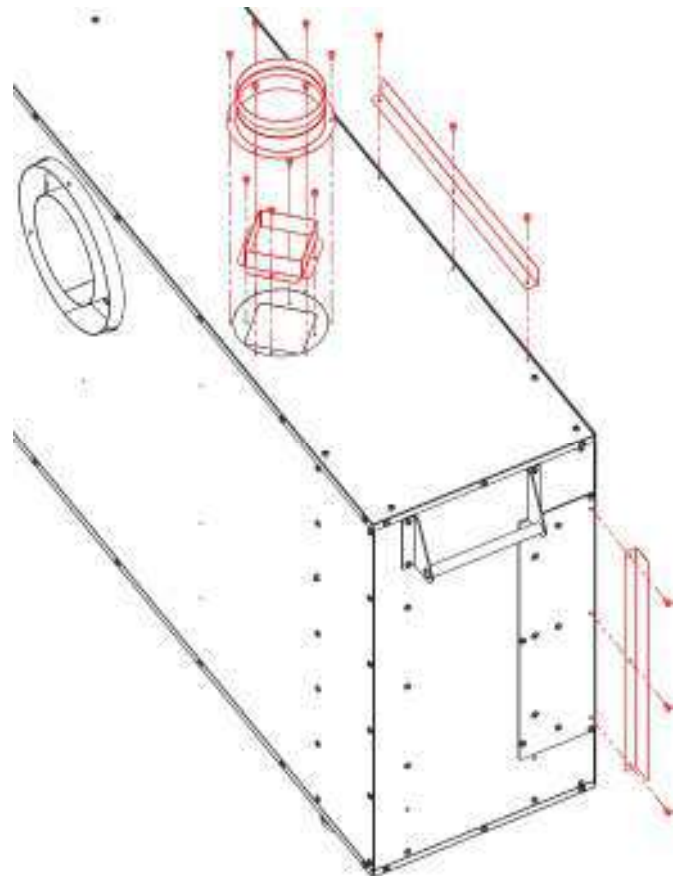

Flue Pipe

4.1.1 The following diagram shows the maximum and minimum distances from the face of the clamped flange on the appliance (Or the front face of the metal studding BEFORE the non combustible board is applied) to the external wall.

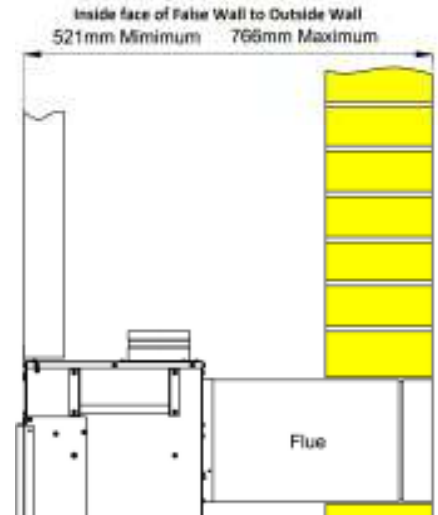

Cut the Flue

The diagram above shows the range of installation depths which can be accommodated when the flue is attached to the appliance. If the distance from the front face of the inside false wall to the outside wall exceeds 766mm the installation cannot proceed. In most installations the flue section will need to be cut to the appropriate size. Any reduction to flue length must be removed from the end **opposite** the terminal.

The diagram below shows how much the flue should be reduced by to suit the particular installation depth. For example, if the dimension from the appliance flange to the outside wall is measures 633mm, then the flue lengths should both be reduced by 130mm.

Dimension "A" is the distance from the face of the clamped flange on the appliance (Or the front face of the metal studding BEFORE the non combustible board is applied) to the ex-

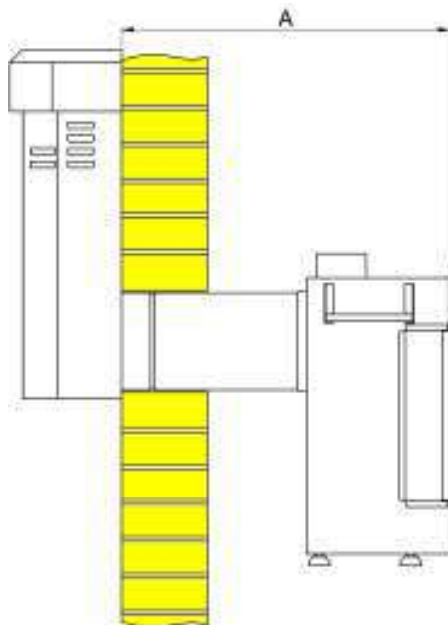

A	Amount of flue to remove
> 520 to 525	240
> 525 to 530	235
> 530 to 535	230
> 535 to 540	225
> 540 to 545	220
> 545 to 550	215
> 550 to 555	210
> 555 to 560	205
> 560 to 565	200
> 565 to 570	195
> 570 to 575	190
> 575 to 580	185
> 580 to 585	180
> 585 to 590	175
> 590 to 595	170
> 595 to 600	165
> 600 to 605	160
> 605 to 610	155
> 610 to 615	150
> 615 to 620	145
> 620 to 625	140
> 625 to 630	135
> 630 to 635	130
> 635 to 640	125
> 640 to 645	120
> 645 to 650	115
> 650 to 655	110
> 655 to 660	105
> 660 to 665	100
> 665 to 670	95
> 670 to 675	90
> 675 to 680	85
> 680 to 685	80
> 685 to 690	75
> 690 to 695	70
> 695 to 700	65
> 700 to 705	60
> 705 to 710	55
> 710 to 715	50
> 715 to 720	45
> 720 to 725	40
> 725 to 730	35
> 730 to 735	30
> 735 to 740	25
> 740 to 745	20
> 745 to 750	15
> 750 to 755	10
> 755 to 760	5
> 760 to 765	0

Important Note:

If the flue components are cut to an incorrect length, replacements will need to be purchased from the manufacturer. Take great care to measure and remeasure prior to cutting the flue to ensure you are happy with the amount of material to remove.

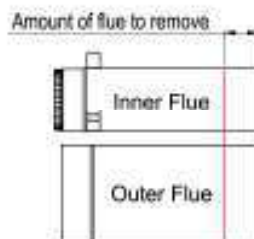

Install the Flue

- The flue hole must be 9" (230mm) diameter and located at a height of 498mm from the base line of the appliance.
- Connect the inner flue to the appliance by pushing it firmly into the rear spigot.
- The outer flue should be screwed to the flange on the appliance by drilling three 3.5mm diameter holes to align with the holes on the flange.
- The inner and outer flue will align with the inner flues pre-installed guides.

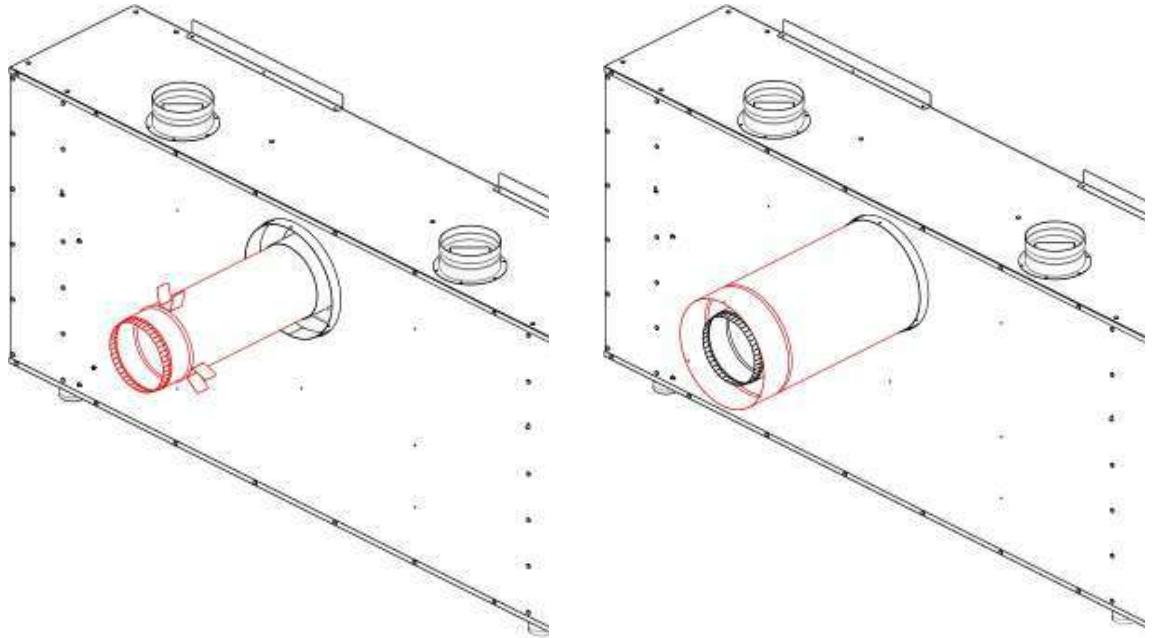

Fit Terminal

4.1.2 After removing the terminal from its packaging remove the 9 screws as shown to disassemble.

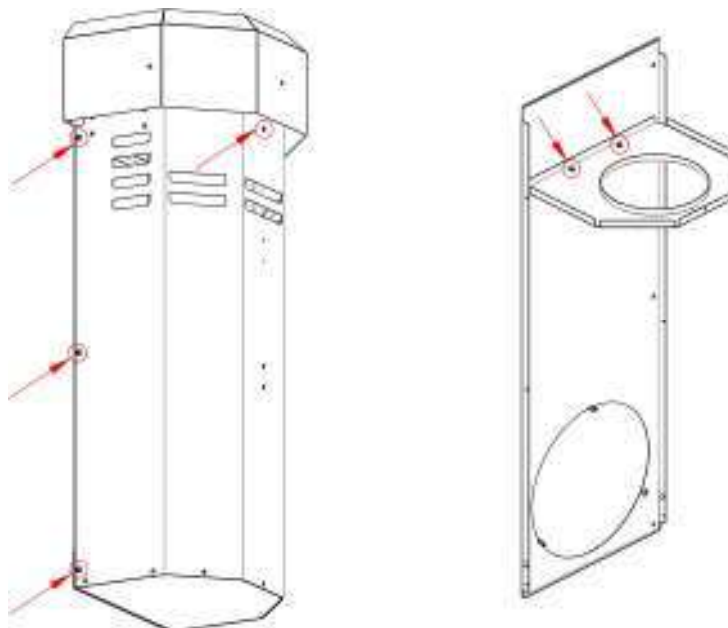

Fit Terminal

Now secure the wall plate to the exterior wall and secure the outer flue (see note below).

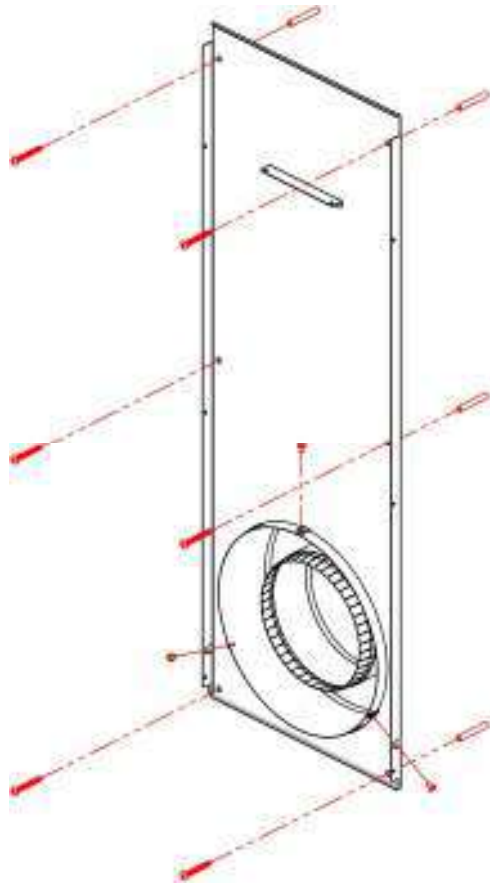

Drill three 3mm diameter holes in the outer flue and fix to wall plate as shown in this diagram.

Next fit the outlet flue elbow and vertical flue section as shown in the diagram below

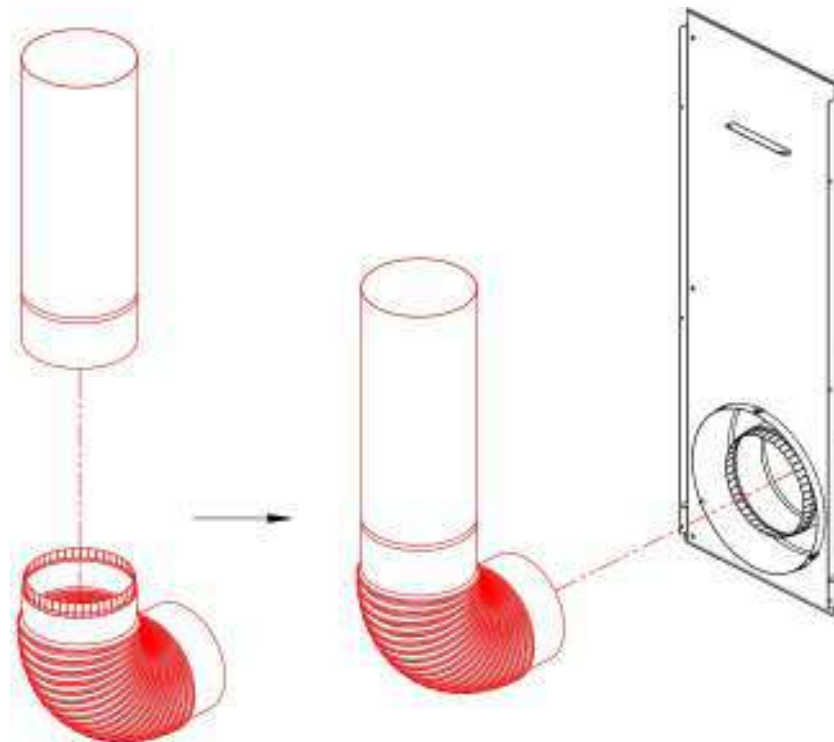

Fit Terminal

Next, fit the vertical flue alignment bracket using the 2 screws removed earlier.

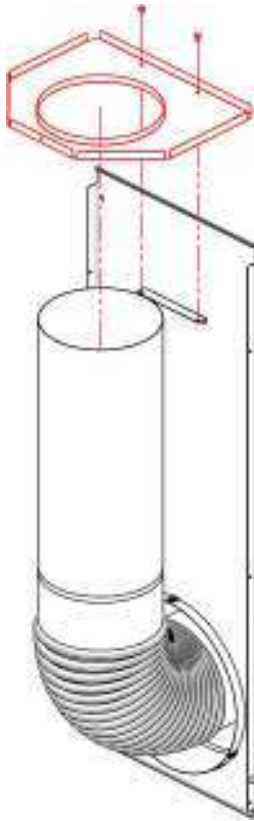

Now slide the terminal cover into position, ensuring the vertical flue alignment bracket is located **between the two guide brackets** on the inside of the terminal body.

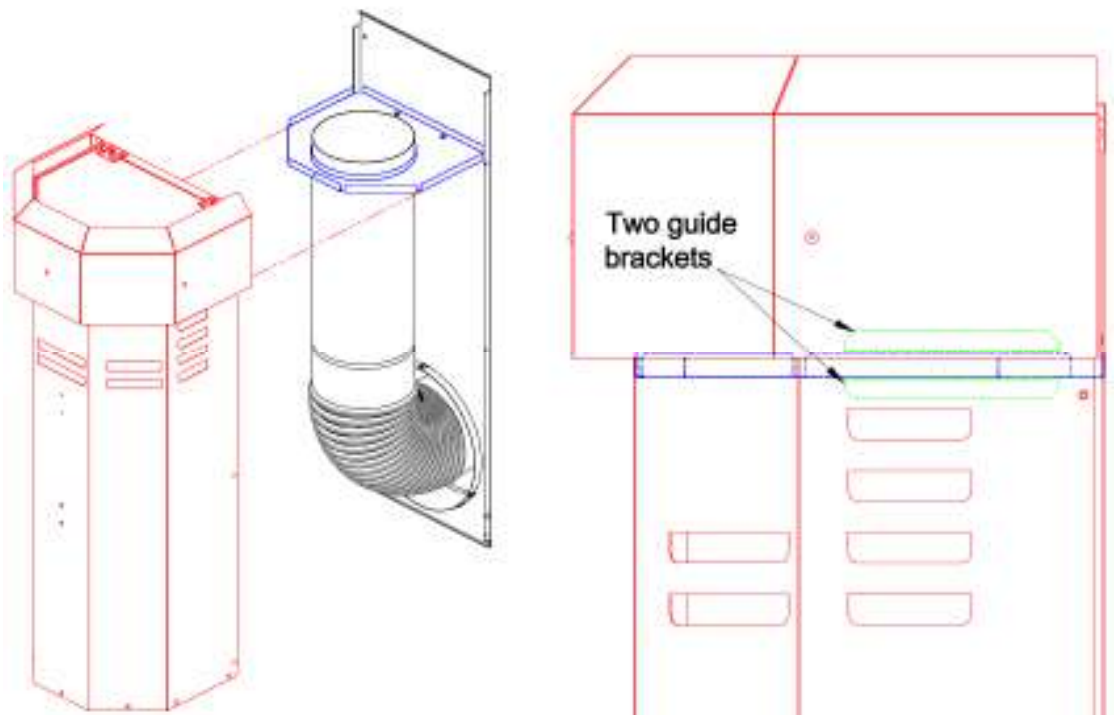

Fit Terminal

Now refit the 7 screws removed earlier..

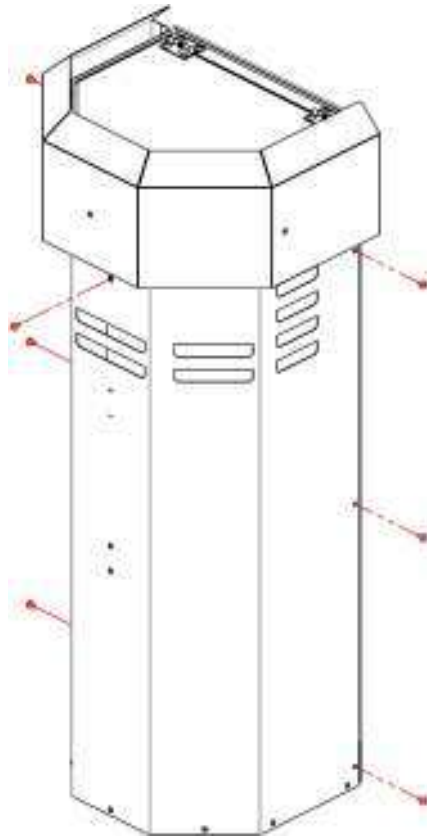

Fit Basket

4.1.3 Fold the wire basket as shown in the diagram below.

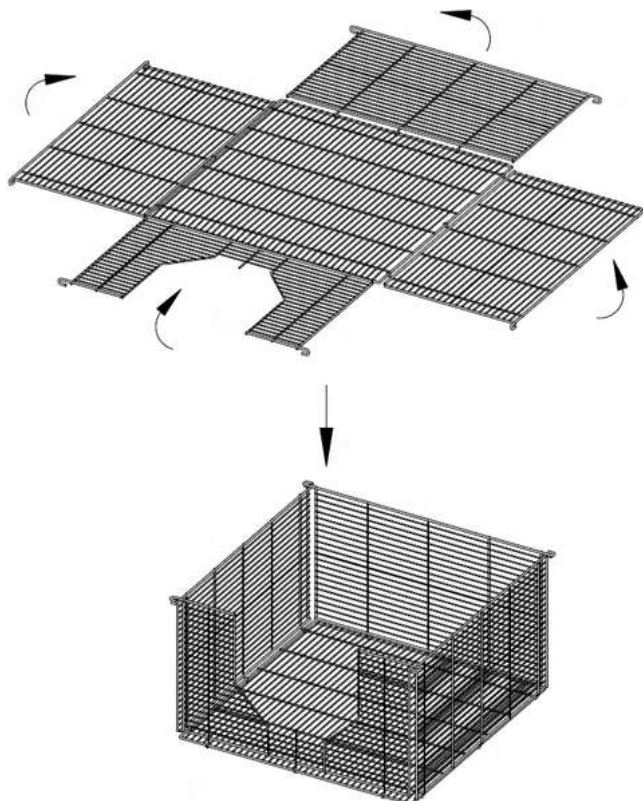

Fit Terminal

Align the wire basket so that the prong locates into the **UPPER** of the two holes on the front of the terminal.

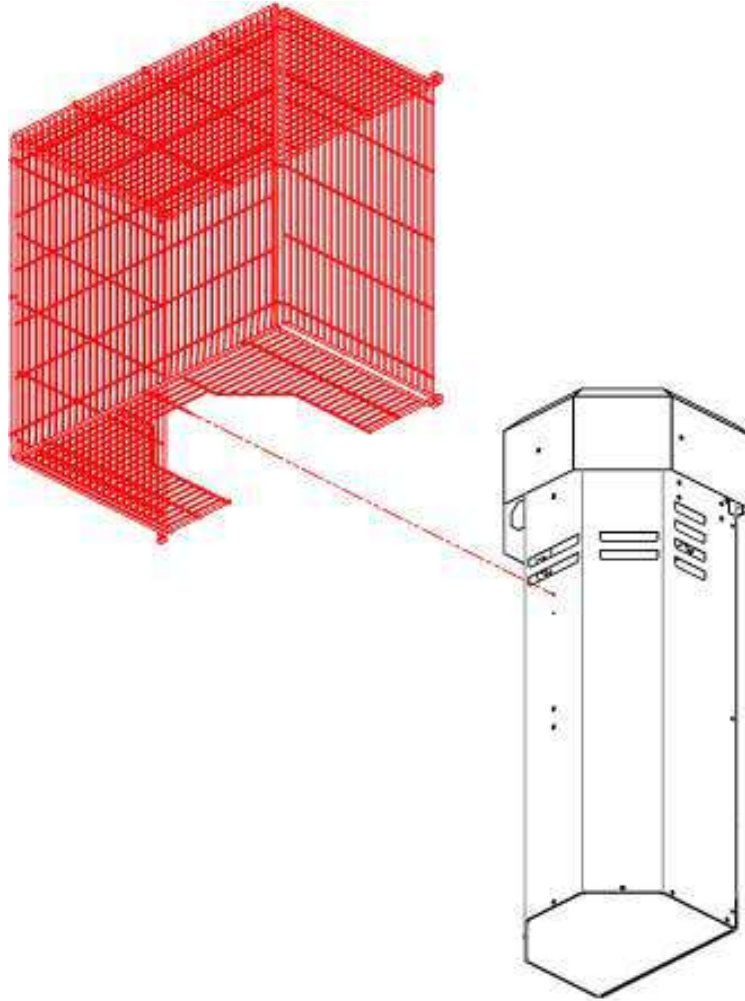

Note: If required, a second basket can be installed in lower position using the prong to locate in the lower hole (drilled to 3mm diameter). This is not a requirement but is available as an additional option.

Finally, secure the wire basket to the wall using the 4 screws and wall plugs provided.

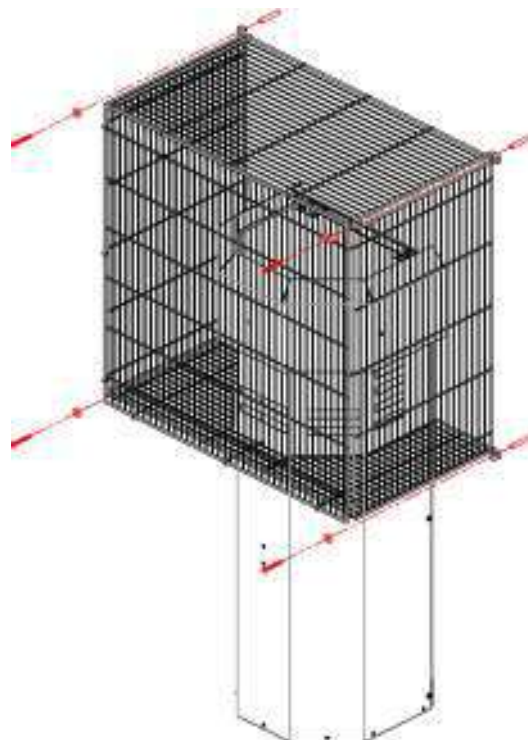

Metal Studding

4.2.1 The installation of this appliance requires a framework of metal studding to be constructed to support the non combustibile boarding. This framework can be used to construct housings for a TV, Sound bar, convection outlets, and any other features required for the media wall installation.

- The appliance must stand on a non-combustible surface with a minimum thickness of 100mm. Concrete or thermalite blocks are recommended to set the appliance at the required height for the installation.
- There is no requirement for cooling air to enter the false cavity produced with this framework as it is provided by the grills on the appliance trim. The convection outlet is provided by the two extendible 120mm dia. Flexible ducts and the two side convection outlets (supplied).
- If the framework is constructed as an entire flat wall (not chimney breast form) then the linear convection kit should be used. (Purchased separately)
- See page 19 for details of areas to be clear of all combustibile materials.



Metal Studding

- **4.2.2 IMPORTANT NOTE:** Under no circumstances should the fire be securely fixed to the metal studding. This will cause excessive creaking and expansion noise as the product heats and cools. The 4 flanges which sit on the top and sides of the appliance should be clamped between the metal stud and the non combustible board. This will secure the appliance and allow it to move freely during its operating cycle.

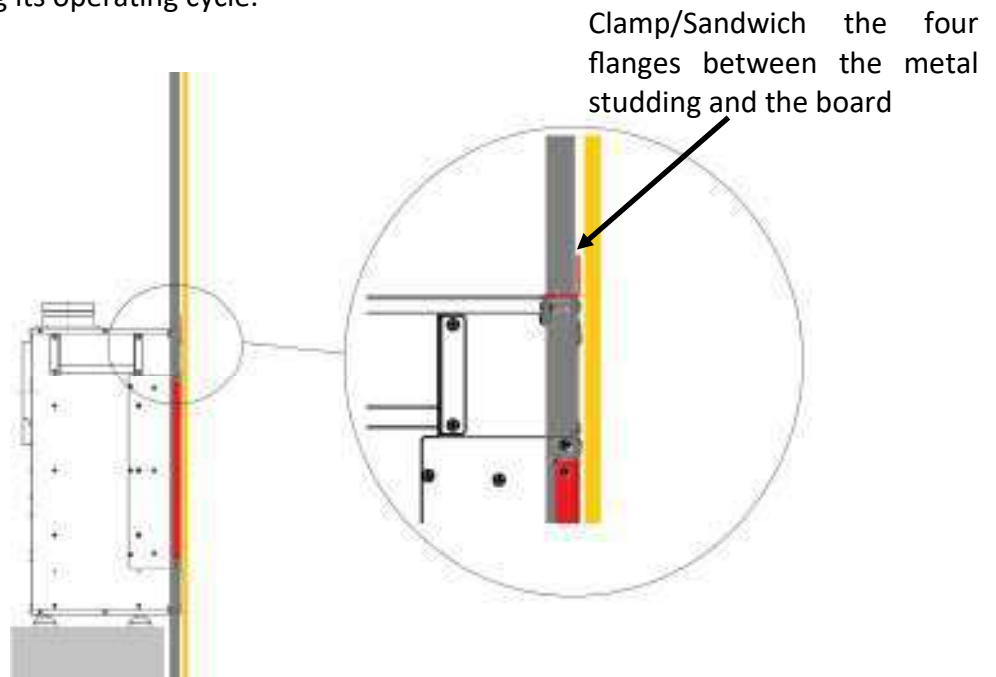

Note: The four flanges sit in front of the metal studding, these will be clamped between the studding and the board.

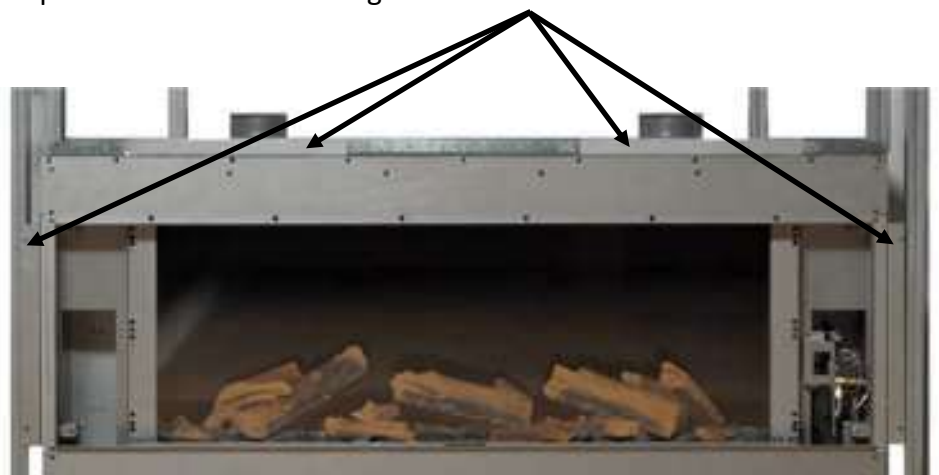

Connecting
To Gas Supply

4.3 Connecting the Appliance to the Gas Supply

The gas supply should be connected to the appliance from the lower right hand side. In all installation conditions the gas connection should be provided using 8mm (O/D) copper tubing. **No soldered joints** should be used within the firebox of the appliance. The blind grommet which is supplied in the standard fitting pack **MUST** be used to close up the gas entry hole—simply cut a small cross with a sharp knife in the centre of the grommet—this will then seal around the gas pipe to provide a tight seal.

Before connecting the gas supply to the appliance the **supply should be purged** to ensure no debris can enter the appliance and a gas soundness test should be performed to ensure that the existing pipe work in the property is sound.

The following diagrams show the access to the inlet gas pipe where the isolation valve should be fitted.

The gas connection should be made to the appliance by the 8mm isolation valve supplied with the appliance. This isolator elbow is supplied loose and should be fitted as per the label on the instruction packet.

Test the operating pressure of the appliance by attaching a pressure gauge to the test point of the appliance. This connection should take place when the appliance is OFF. Ensure that gas is turned on at the gas meter.

The isolation valve should be fitted in the position shown below to ensure that the test point and isolation screw are both accessible. The gas entry point can also be seen in this diagram.

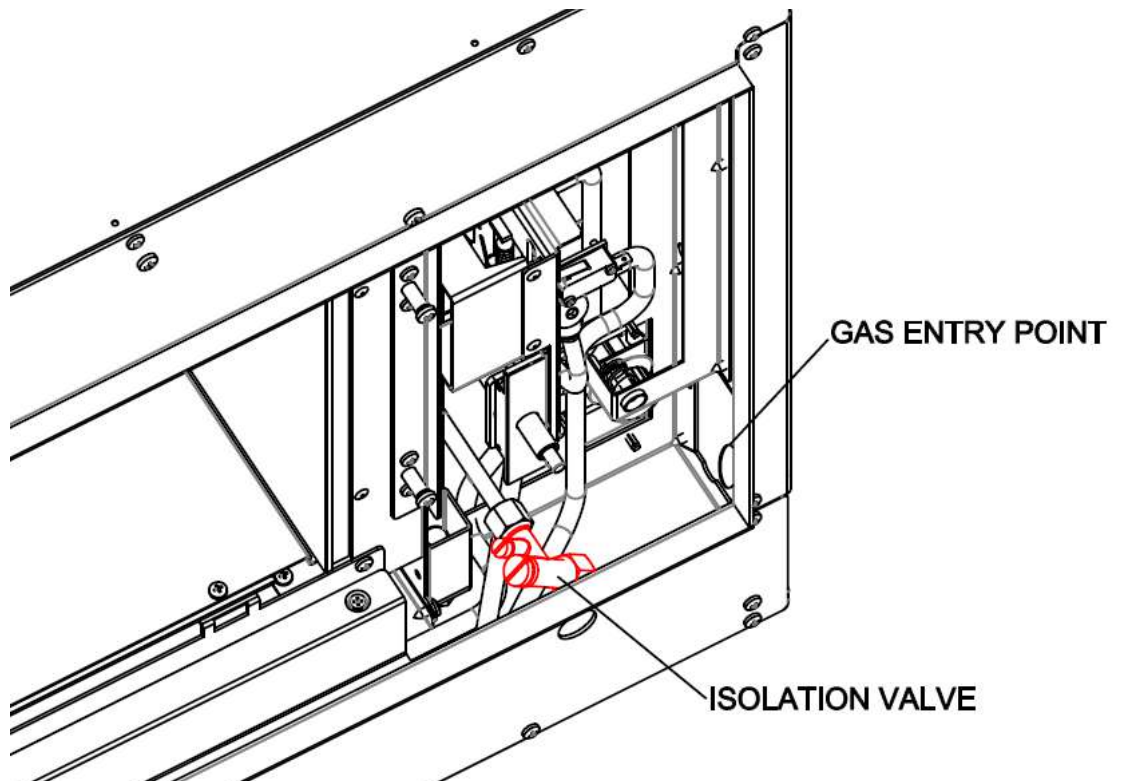

Log Setup

4.4 The following instructions detail how the ceramic fuel bed and loose components are to be installed onto the appliance. Great care should be taken when handling these ceramic parts as they are fragile and can easily be broken. Do not force any component into position, if it does not fit easily then you are not fitting the part correctly. These instructions can also be followed to remove or reinstall the fuel bed after cleaning. This is a procedure that can be undertaken by the customer as required and the frequency will be depend upon use.

See page 21 for glass door removal and installation.

The fuel bed setup involves the installation of volcanic rock, ceramic bark, ember wire and a boxed set of ceramic decorative logs. These components will have been installed by your gas engineer at the point of installation, however it is permitted for the end user to remove clean and replace these components as necessary. The following installation instructions must be adhered to at all times.

The following diagram is for identification purposes. It is imperative that the logs are placed in the correct position for safety and also to ensure that you obtain optimal performance from your appliance. If the flame picture appears to be abnormal, it may be that one or all of the three main logs has been positioned incorrectly. Ensure the correct logs are installed onto the correct burner. If popping noises are heard, this is also indicative of incorrectly placed logs or volcanic rock placed too close together.

Identify

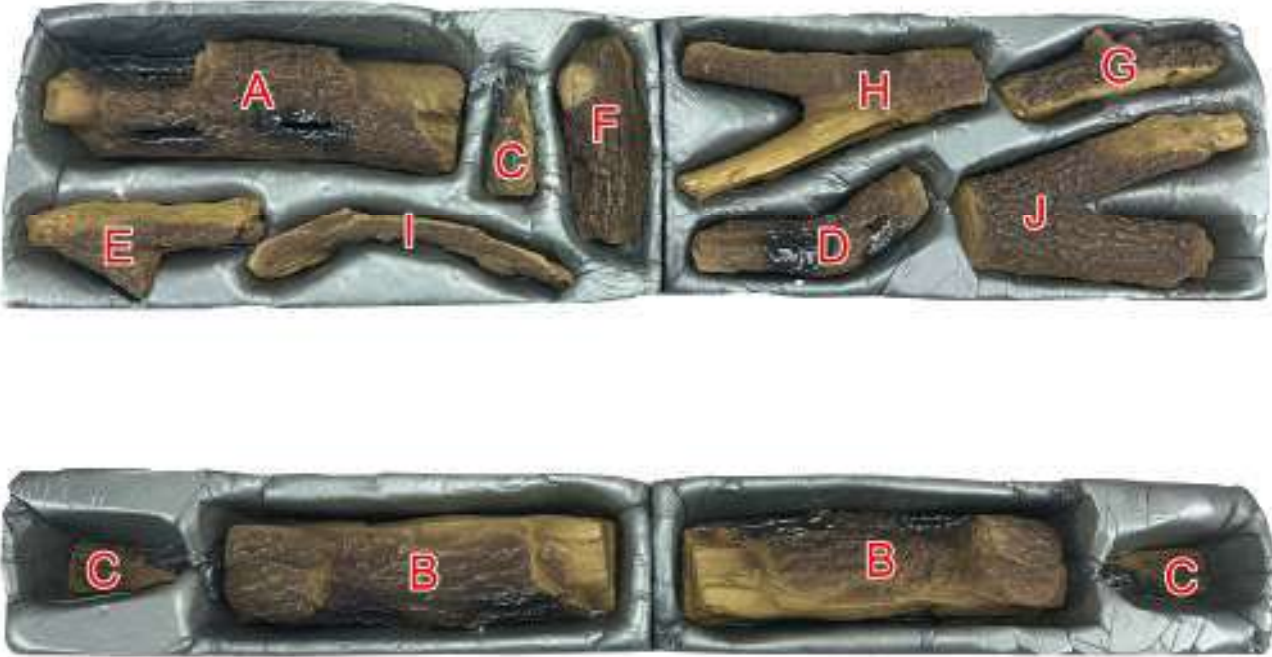

Fuel Bed

Place the volcanic rock on top of the centre burner, which runs across the base of the fire, as shown. Ensure a 4-5 mm gap is left between each piece. Then using **half** of the glowing ember wire supplied, ruffle between fingers to make it loose, about 10mm wide and long enough to cover the visible volcanic rock then align over the rock as shown. Ensure **no wire is placed within 25mm of the pilot assembly**. Retain the other half of the wire for replacement at annual service.



Place Log A and the two Log B's as shown in the picture below.

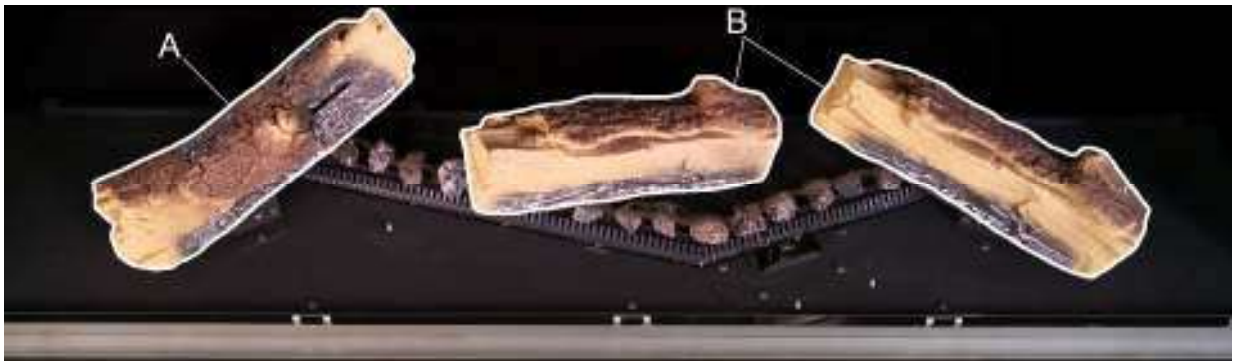

Place Log C as shown in the picture below.

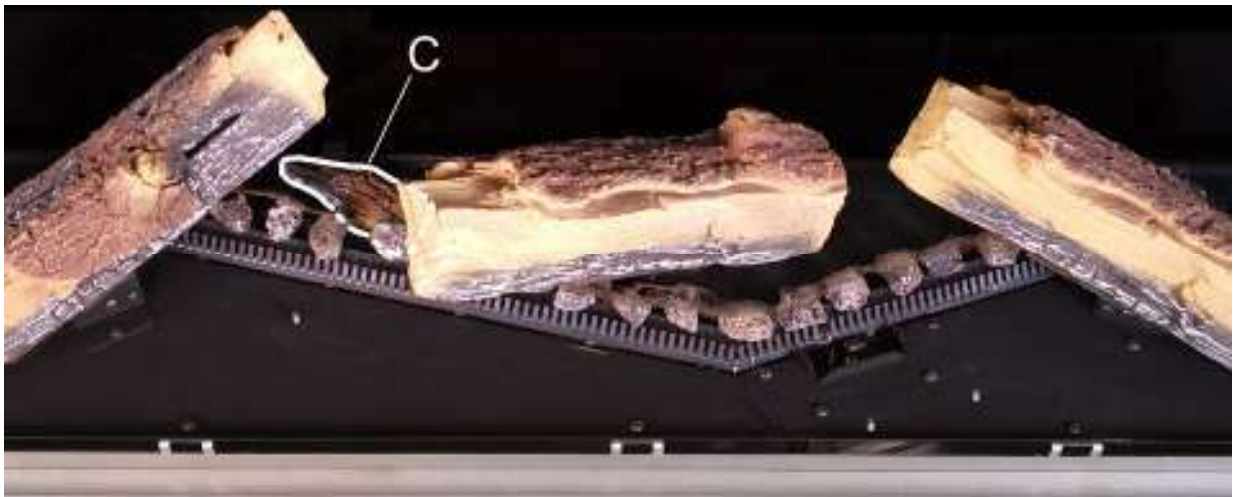

Place Log D onto the fuel bed as shown below, ensuring it fits **securely over the raised pin**.



Place Log E in the orientation shown.

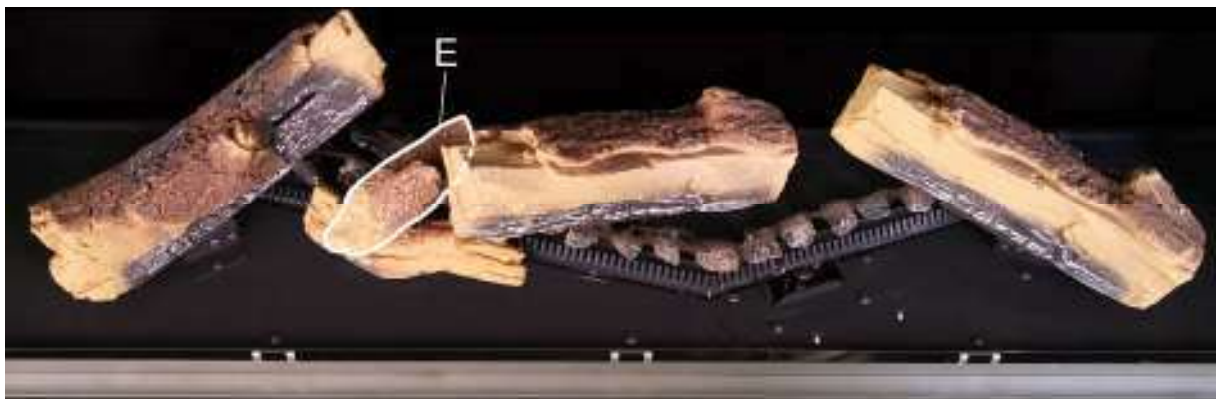

Place Log F in the orientation shown below. This log sits **securely on two pins** protruding from the fuel bed.



INSTALLATION INSTRUCTIONS

Sit Log G onto Log F as shown.



Place Log H against Log A as shown. Ensure the lower limb sits just in front of the air slot. Sit Log I onto the fuel bed while resting the upper portion against the small bump on Log B.



Place Log J against Log C as shown.



Place the bark around the fuel bed as shown. Ensure that no bark can interfere with the pilot operation.



Place one of the Log C's onto the burner bed as shown.



Place the other Log C onto the burner bed as shown.



Refit Glass door

4.5.1 To refit the glass door, attach the suction cups then lower the bottom edge into the cavity at the base of the appliance.

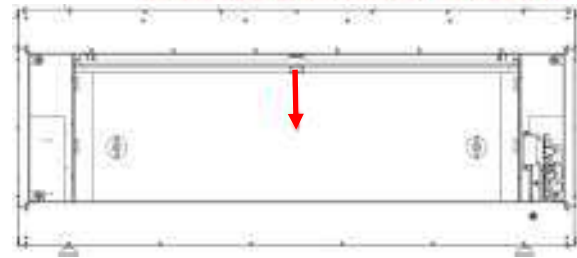

Now rotate the top of the glass inwards.

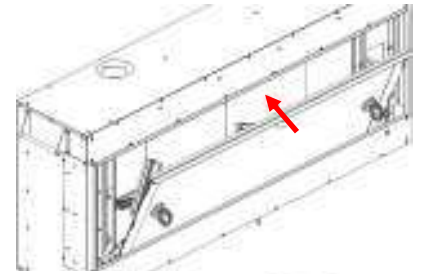

Lift the glass door and insert the tab at the top of glass door to the slot on the top, and sit the frame on the lower edge of the combustion chamber.

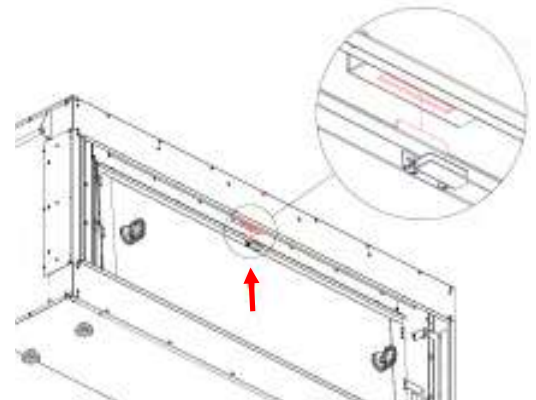

Secure the glass door with the 8 screws. 3 vertically on each side and 2 on the bottom.

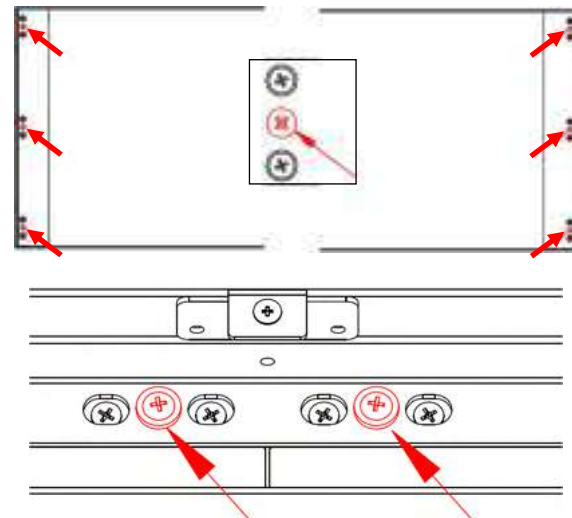

Never run the appliance with a damaged or broken glass panel

Trim Installation

3.5.2 Once the non-combustible board has been fixed to the studding, the trim can now be fitted to complete the installation.

Ensure that the trim is retained by the bracket at the top of the fire.

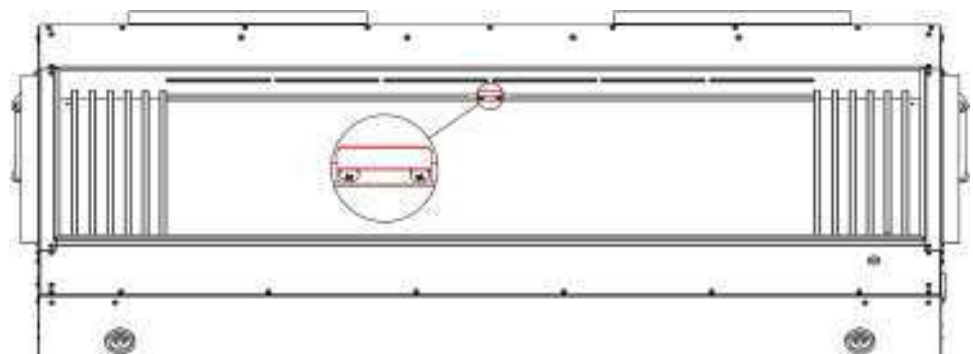

Trim Installation

Also ensure that the trim is retained at the its base by locating the screw on the lower edge of the glass door into the slot on the lower edge of the trim.

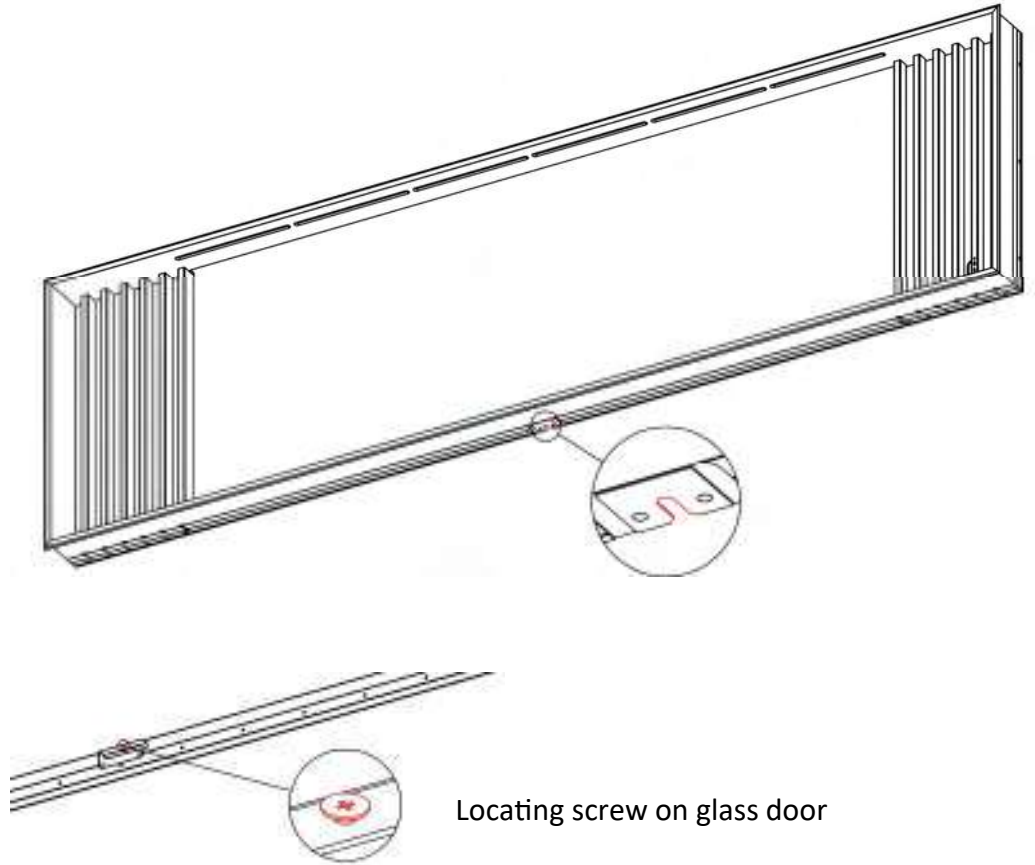

Using the Allen key tool (supplied), tighten the four corner, self locating screws.

Ensure this tool is left with the customer—they will need this to clean the glass or to replace the battery.

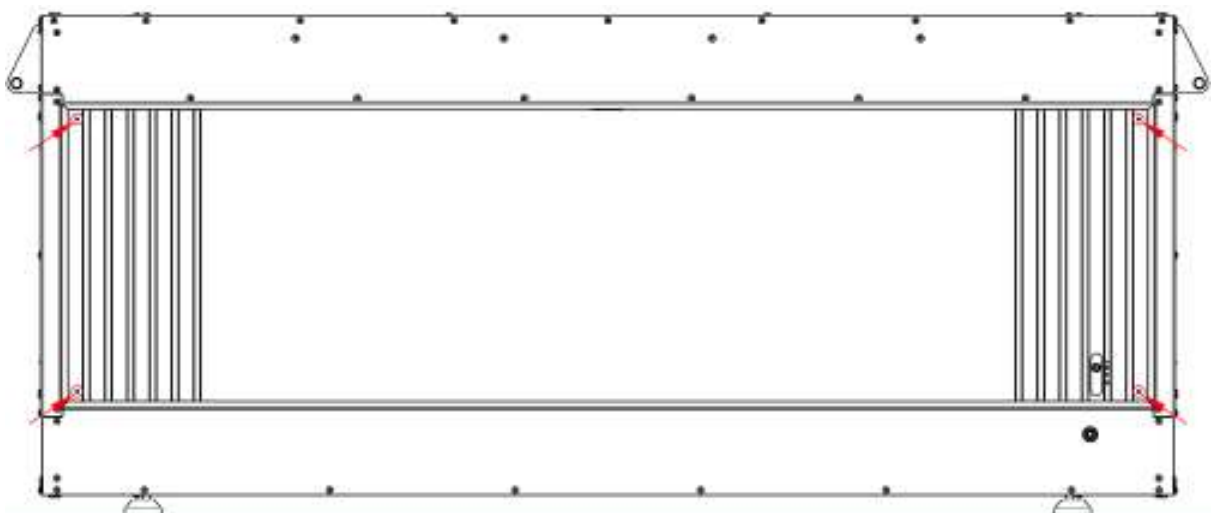
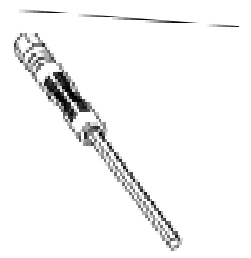

Controls

4.6.1 This appliance has a concealed slide control knob. It is discreetly concealed in the grill on the right hand side of the appliance. Simply press the knob and it will protrude from its current position to enable operation.

The knob will slide up and down, this movement controls all functionality of the appliance, from ignition, flame control and turning the appliance off. When the desired operation is complete, simply press the knob inwards and it will return to its stowed position.

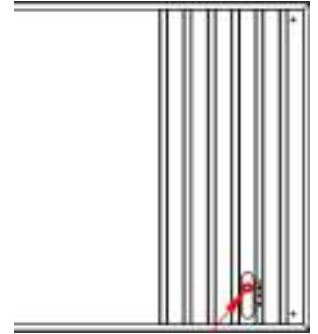

Lighting

4.6.2 Slide the control knob down to the ignition symbol. After a few seconds the pilot light should light.

If the pilot light does not light, release the control knob and wait for 3 minutes before reattempting. If the pilot does not light after 3 attempts,

Check the battery—see page 6 and also check that the ember wire is not sitting near the pilot causing a short circuit.

If the battery is new and the pilot still fails to light, contact a gas safe engineer.

Once the pilot is lit, keep the lever pushed down for up to 10 seconds then release. The pilot should stay lit and the central and front log burners will now light.

The appliance is now running at the LOW setting.

Slide the knob slowly upwards to turn the rear log burners on. The appliance is now running at the HIGH setting.

To turn the fire off, slide the lever all the way to top to the OFF symbol.

Should the spark generator fail to provide a spark at the electrode it may be that a small amount of soot or ember wire has fallen from the fuel bed onto the pilot assembly, causing a short circuit. If this is the case, ensuring the appliance is off and cold, this area can be cleaned with the thin nozzle from a vacuum cleaner. See page 21 for details on glass removal to access this area.

Alternatively check the battery is in good condition—see page 6 for details.



Complete the
Installation

4.7 INFORM THE CUSTOMER OF THE FOLLOWING TO COMPLETE THE INSTALLATION

Demonstrate the lighting of the appliance and the controls to control the heat settings. Demonstrate how to turn the fire off.

Demonstrate the removal of the trim, access to the battery compartment and how to reinstall correctly.

Discuss the removal and reinstallation of the glass door and the ceramics. Explain how they should be cleaned and make the customer aware of the health and safety warning detailed later in these instructions.

Explain to the customer that the ceramics are fragile and must be treated with great care, explain that the ceramics are not covered by the warranty because of their fragility. Also explain that small hairline cracks will appear in the surface of the ceramics due to heat expansion and contraction—this is perfectly normal.

During the first several hours of use an odour will be experienced—this is normal and is the starch oils and paints used in the manufacturing process. This odour is non toxic and will eventually disappear with use.

Advise the customer that ALL glass fronted gas appliances will leave condensation on the inside face of the glass when first lit—this is perfectly normal and is a result of the water vapour present in the combustion products hitting the cold glass surface. This condensate will disappear over the next minute or so. It is also important to advise the customer that this condensate will carry with it any **impurities in the air** and will therefore, with use, leave a **slight grey condensation mark** on the inside of the glass. We advise that this is cleaned off maybe 2 to 3 times a year, dependant on use.

Advise that no rubbish should be thrown onto the appliance and that the appliance should be cleaned regularly.

Advise the customer that the appliance should be serviced annually by a gas safe engineer to ensure the safety and integrity of the appliance.

Advise the customer that the appliance has a naked flame and therefore it is essential that a suitable fireguard be used for the protection of the elderly, infirm and young children. This fireguard should conform to BS8423 : 2002 (Fireguards or use with Gas Heating Appliances).

These instructions and all supplied installation tools must be handed over to the customer once installation is complete.

Servicing

5.0 Servicing the Appliance.

The following procedures can and should **only** be performed by a **Gas Safe registered installer**.

This appliance should be serviced annually by a **Gas Safe registered installer**.



Removal/Replacement of Gas Carrying Parts

The removal and replacement of all the gas carrying components will require the removal of the trim and glass door—see earlier pages for details. The following information details the removal of components. **Replacement parts must be obtained from the manufacturer directly.** No gas carrying components are available through any other source. Failure to install the correct component may cause damage or injury and will void warranty. Refer to the relevant section that follows detailing the removal of the specific component (s).

Before any service works commences take note of the following:

- Remove the trim and the glass door. See page 21.
- Turn off the gas supply at the isolation valve on the appliance. Ensure the appliance is cold.
- Remove the fuel effect components - put in a suitable location where they cannot be damaged.
- Isolate the gas supply at the restrictor elbow.

5.1 Removal/Replacement of Thermocouple or Pilot Assembly

Remove the six screws surrounding the pilot assembly. Then remove the 4 screws to release the right hand lower access panel as shown below.

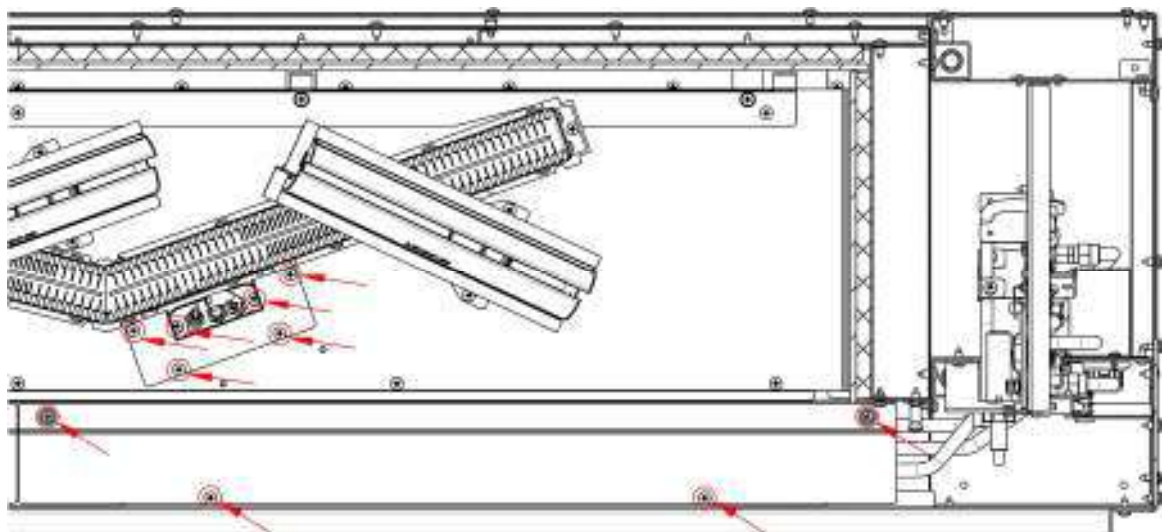

Servicing

Removal/Replacement of Pilot Assembly

Next, carefully lift the pilot upwards from the burner tray.

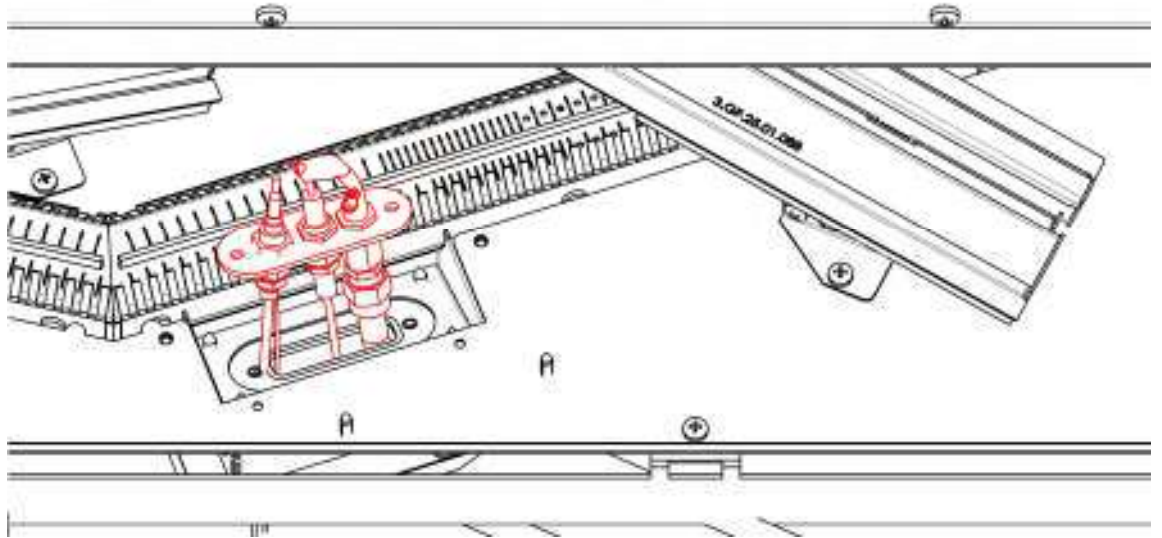

Removal/Replacement of Pilot Assembly

If only the thermocouple is being replaced, loosen the lower nut and the head of the thermocouple can be lowered from the pilot body.

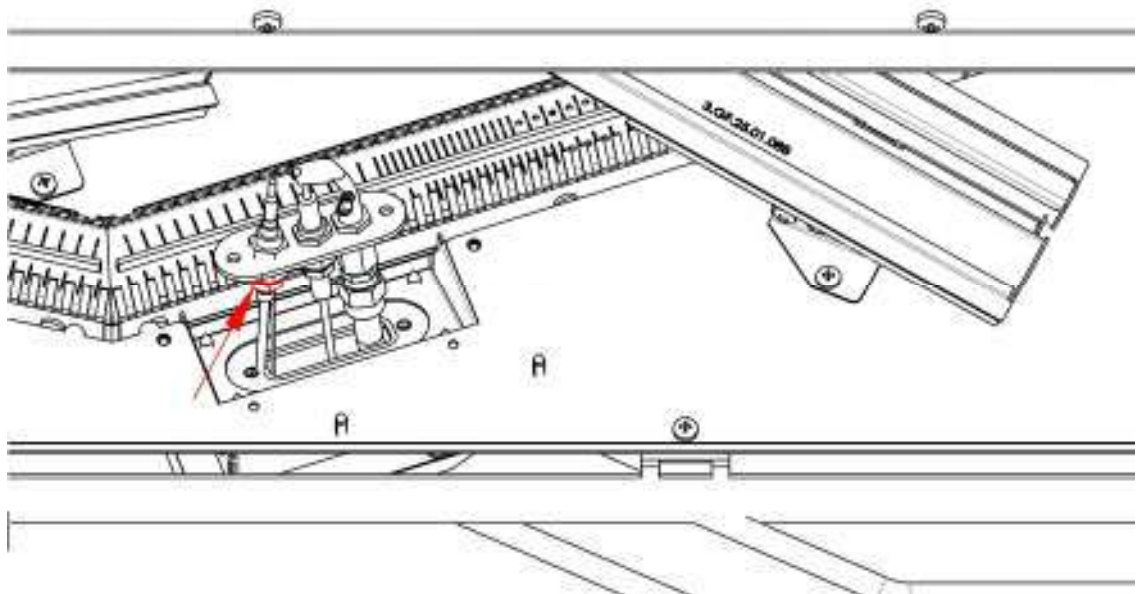

Servicing

Removal/Replacement of Pilot Assembly

If the entire pilot is being removed/replaced, loosen the tube nut below the pilot hood and the gas feed tube can be lowered from the pilot assembly. Pull gently on the H.T. lead to remove it from the spark electrode. The pilot body can now be removed.

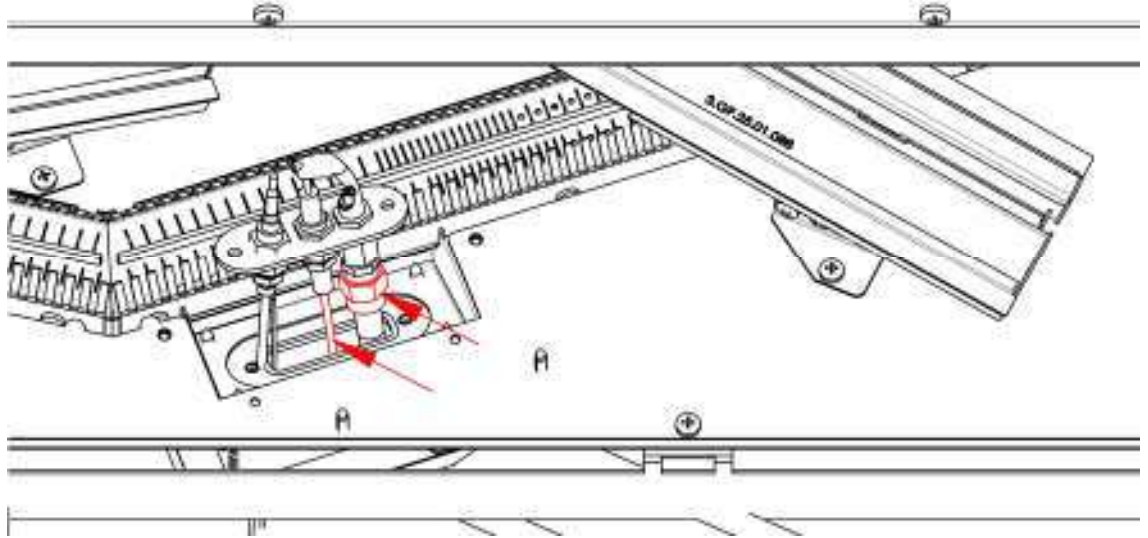

Removal/Replacement of Pilot Assembly

After removing the control module—see page 44, the micro-switch and thermocouple nut must now be removed to complete the removal of the thermocouple assembly.

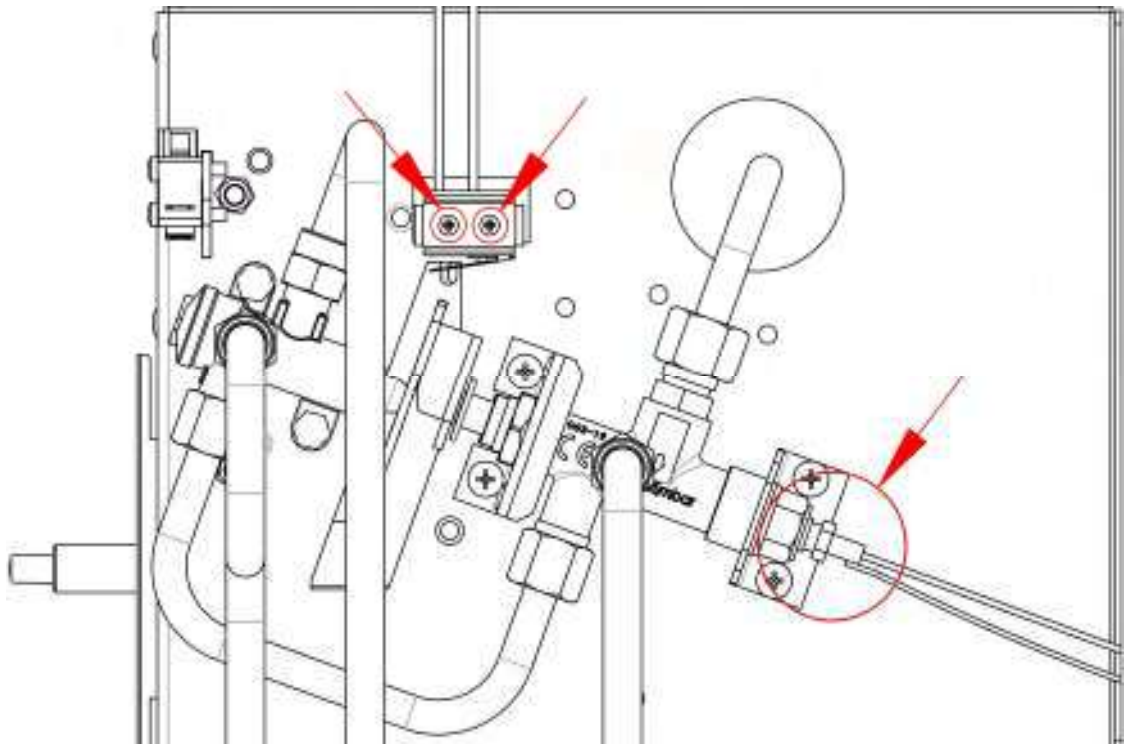

Servicing

5.2 Removal/Replacement of the Slide Valve

To remove the main slide valve, proceed as follows:

First, the control module can be moved. Remove the two screws as shown and slide the module off the two locating pins.

Remove the thermocouple nut from the base of the valve.

Remove the two screws at the base of the valve either side of the thermocouple nut.

Undo the 3 gas tube nuts, gas inlet, pilot outlet and main gas outlet.

Finally, undo the lock nut at the head of the slide valve.

The slide valve is now released and can be replaced.

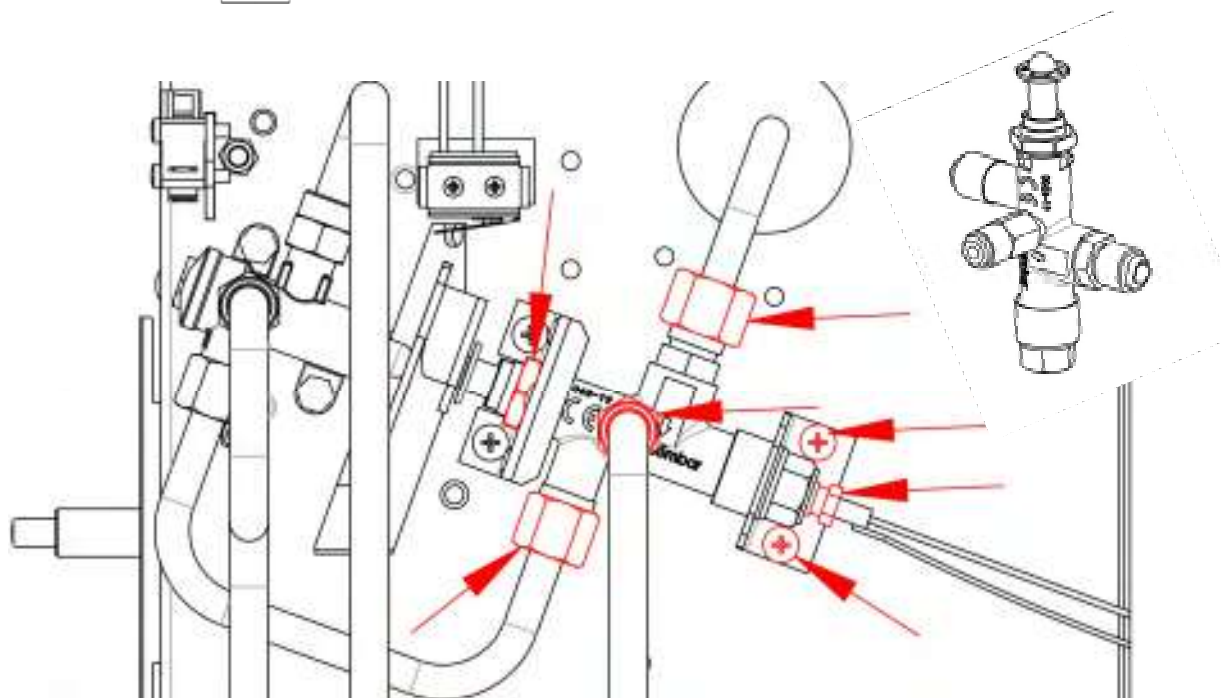
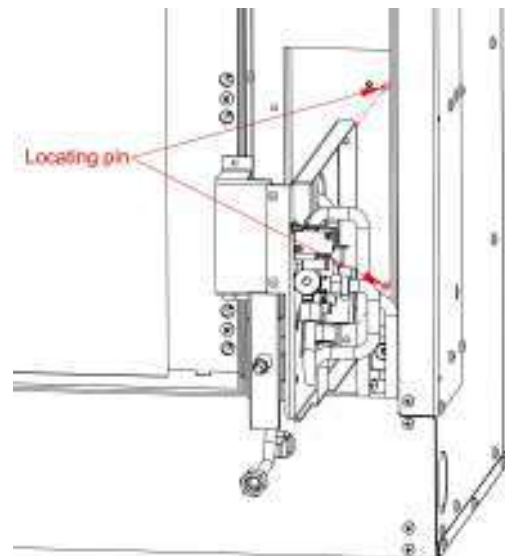
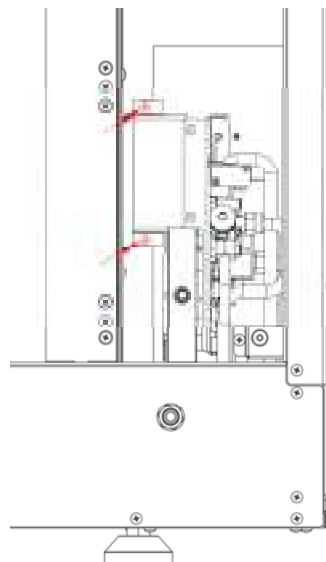

Servicing

5.3 Removal/Replacement of the Tee Valve

To remove the Tee valve, proceed as follows:

First see control module removal on page 44.

Undo the 3 gas tube nuts as shown below.

Remove the two screws at the base of the valve either side of the Tee Valve

The slide valve is now released and can be replaced.

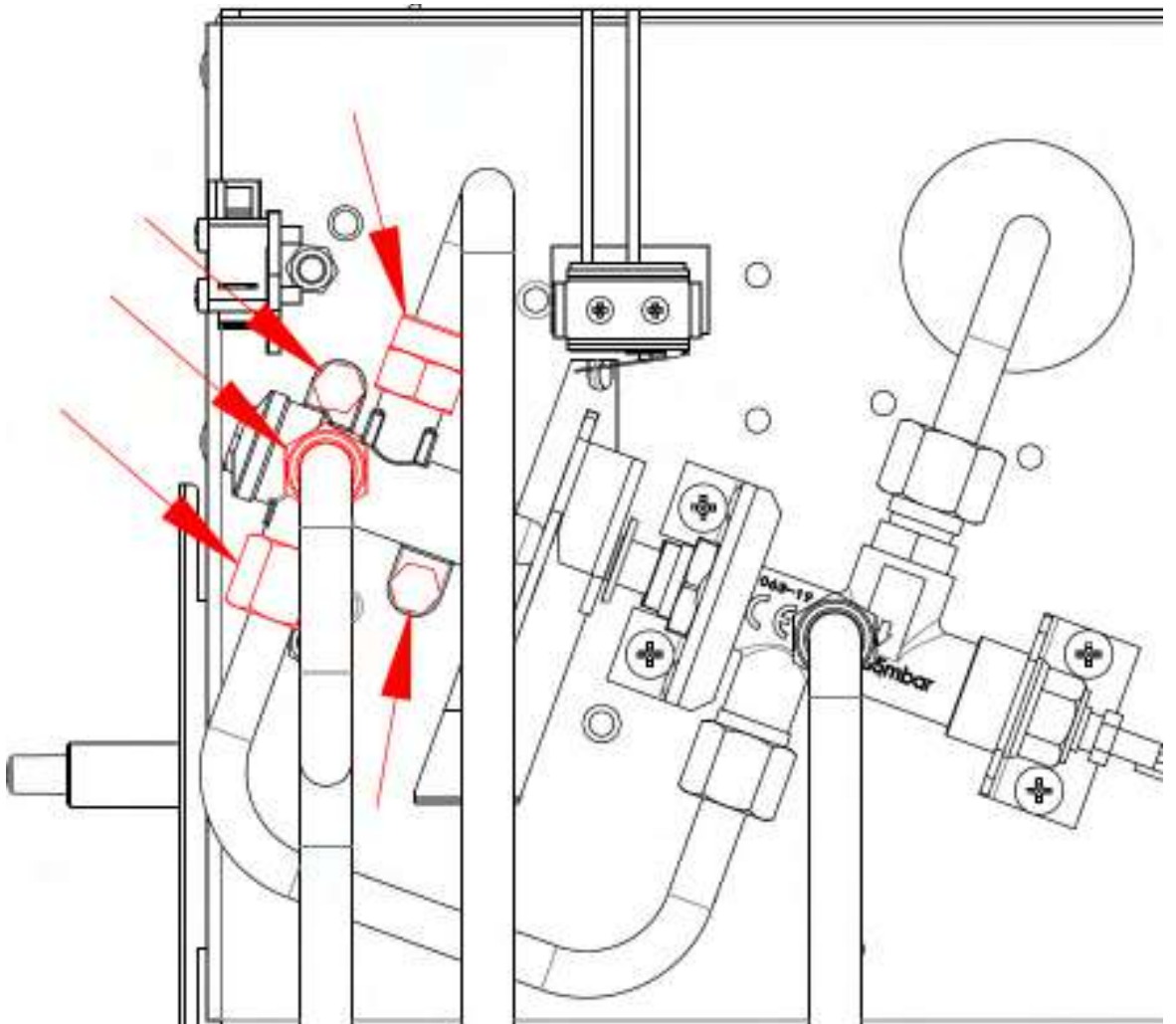

Servicing

5.4 Removal/Replacement of the Main Burner Injectors

This appliance has 7 main burner injectors, two supplying each log burner and one to supply the central burner.

To remove the main burner injectors, proceed as follows:

First, remove the log burners (3 off) by removing the 2 screws to each burner assembly. **These burners are NOT interchangeable, make a note of the correct location of each burner as it is removed.**

Now remove the 4 screws to release the central burner as shown.

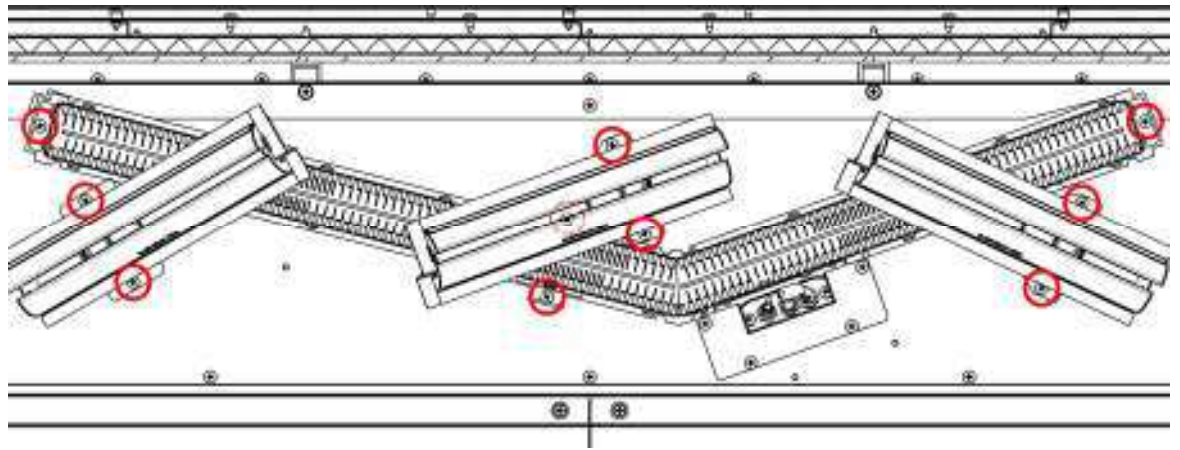

The main burner injectors can now be seen and can be removed with a 7mm box spanner.

Important Note: This appliance contains 4 different injector sizes as shown in the diagram below. Do not mix these injectors else the product will not perform correctly.

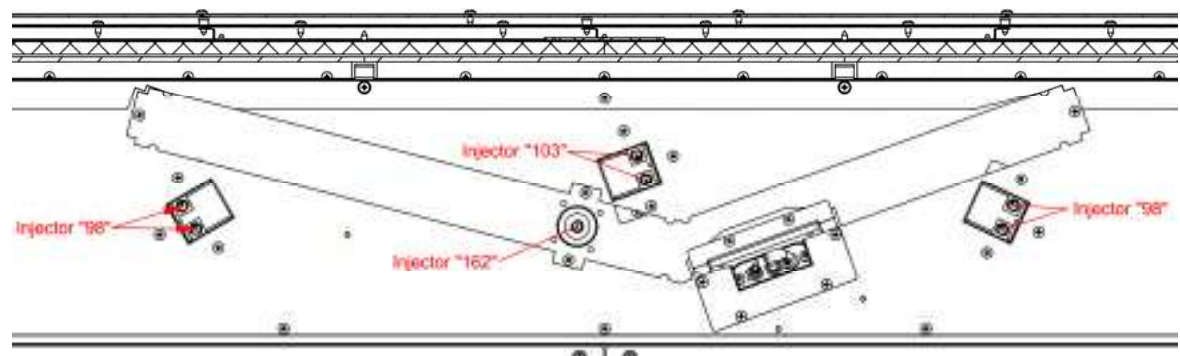

Servicing

5.5 Removal/Replacement of the Side & Back Glass Components

This appliance has 5 black reflective glass panels, to remove or replace these panels follow the instructions below:

First slide out the two side glass panels.

To remove the rear three glass panels, first remove the 4 screws as shown to release the glass retainers.

The rear glass panels can now be removed.

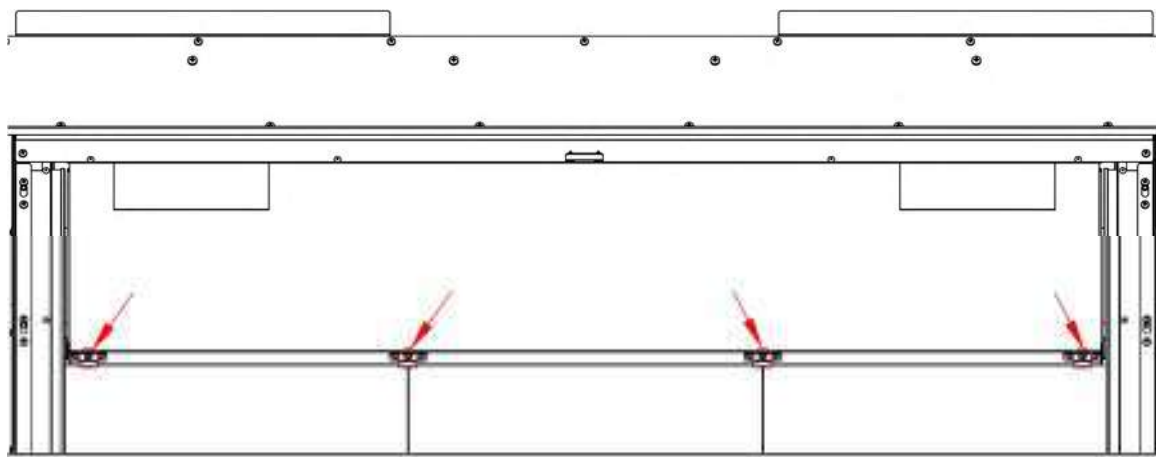

6.0 Record of annual services

The extended warranty of the specified components within this appliance is conditional on the annual service of the appliance by a Gas Safe registered engineer. Failure to maintain the product or to use the product in away which is not intended will void the manufacturer's warranty.

Ensure a record is kept of the annual services conducted by the Gas Safe engineer in the table below.

Service of this appliance must only be conducted by a Gas Safe registered engineer.



Annual Service Record

YEAR 1	Gas Safe Engineer Name:	
	Gas Safe Engineer Registration No.:	
	Date of annual service:	
YEAR 2	Gas Safe Engineer Name:	
	Gas Safe Engineer Registration No.:	
	Date of annual service:	
YEAR 3	Gas Safe Engineer Name:	
	Gas Safe Engineer Registration No.:	
	Date of annual service:	
YEAR 4	Gas Safe Engineer Name:	
	Gas Safe Engineer Registration No.:	
	Date of annual service:	

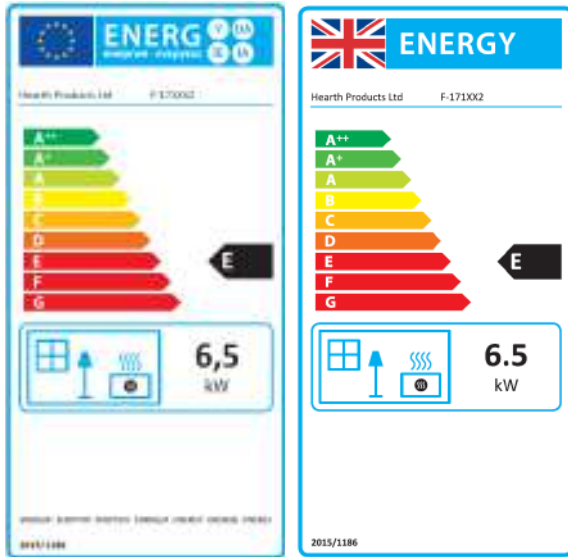

Product Fiche	
Manufacturer :	Hearth Products Ltd
Model No.	F-171XX2
Fuel Type	Natural Gas L _{2H}
Energy Efficiency Class	E
Indirect Heating Functionality	No
Direct Heat Output kW	6.5kW
Indirect Heat Output kW	N/A
EEl	66.2%
Useful Energy Efficiency (NCV)	High : 75.2%
Useful Energy Efficiency (NCV)	N/A
Nominal Heat Output	High : 6.5kW
Nominal Heat Output	Low : 4.4kW
Heat Output Temperature Control	Two Manual Stages
Permanent Pilot Power (kW)	N/A
Space Heating Emissions NO _x (GCV)	130mg/kWh

7.0 Important Note:

The energy efficiency class of this product is defined using a seasonal efficiency calculation which reduces the actual net efficiency of the product where the use of automated heat control, thermostats, window open sensors and timers are not used. This is not to be confused with the net efficiency, or useful efficiency of the appliance (shown in the tables above).

**This product MUST be installed by a Gas Safe Registered Installer. Full details are provided in this manual.
Hearth Products Ltd. Unit 14 Tollgate Industrial Estate, Stafford, ST16 3SU**

This page is intentionally left blank

This page is intentionally left blank

User Replaceable Parts

Part Number	Description
P-XX1243	Ceramic Log Set Complete (includes Volcanic rock & bark)
P-XX1243A—J	Individual logs
P-XX1212A + P-XX1212B	Volcanic Rock Pack
P-XX1213 (3 Packs Required)	Ceramic Bark Pack
P-XX1234	Ember Wire Pack
P-XX140017A	Front Glass Door Assembly
P-XX140017B	Trim Removal Allen Key Tool

To order spare parts for your appliance visit www.hearthproducts.co.uk/sparesshop or call us directly on 01785 225401

It is important to note that the above spares are user serviceable components that can be changed by the customer. The spares shop also features other components which may have to be installed by a Gas Safe engineer. If in doubt please contact us directly.



Hearth Products Ltd
Unit 14 Tollgate Industrial Estate,
Stafford, ST16 3SU

www.hearthproducts.co.uk

Tel: 01785 225401 Fax: 01785 225501

Email: info@hearthproducts.co.uk



Due to our policy of continual product improvement, some diagrams and small details may not be accurate however if there is any concern or matter of understanding that you feel needs to be clarified please contact us directly. Our contact details are shown below.